



INSTRUCTIONS

-J03549

REV. 2015-04-28

NARROW BEACH HANDLEBAR KIT

GENERAL

Kit Number

56857-05A

Models

Ask a Harley-Davidson dealer or refer to the latest Harley-Davidson Genuine Motor Accessories and Genuine Motor Parts catalog to determine if this handlebar can be installed on your motorcycle.

This kit does not fit models equipped with Heated Hand grips, Softail Nacelle Kit (Part Number 67907-96), Hydraulic Clutch Kits, handlebar-mounted gauges or the Road Tech® Radio.

Installation Requirements

Separate purchase of extra parts or accessories may be required for proper installation of this handlebar kit on your model motorcycle. Refer to the latest Harley-Davidson Genuine Motor Accessories and Genuine Motor Parts catalog for a list of required parts or accessories.

Loctite® 271 (Red) Threadlocker and Sealant (H-D Part Number 99671-97) is required for the proper installation of this kit.

Fresh, uncontaminated brake fluid is needed. Refer to your Owner's Manual or the Service Manual for this year and model motorcycle to determine the correct brake fluid.

Motorcycles equipped with a glued left side hand grip require a new grip, sold separately. Refer to the Parts Catalog for replacement stock hand grips.

Ask a Harley-Davidson dealer about the selection of Genuine Motor Accessory hand grips that are available.

WARNING

The rider's safety depends upon the correct installation of this kit. Use the appropriate service manual procedures. If the procedure is not within your capabilities or you do not have the correct tools, have a Harley-Davidson dealer perform the installation. Improper installation of this kit could result in death or serious injury. (00333a)

NOTE

This instruction sheet references Service Manual information. A Service Manual for your model motorcycle is required for this installation. One is available from a Harley-Davidson Dealer.

Kit Contents

See Figure 4 and Table 1.

INSTALLATION

Preparation

WARNING

To prevent accidental vehicle start-up, which could cause death or serious injury, disconnect battery cables (negative (-) cable first) before proceeding. (00307a)

WARNING

Disconnect negative (-) battery cable first. If positive (+) cable should contact ground with negative (-) cable connected, the resulting sparks can cause a battery explosion, which could result in death or serious injury. (00049a)

1. See the service manual. Remove seat. Disconnect negative battery cable. Retain all seat mounting hardware.

WARNING

When servicing the fuel system, do not smoke or allow open flame or sparks in the vicinity. Gasoline is extremely flammable and highly explosive, which could result in death or serious injury. (00330a)

2. Loosen the fuel tank. Refer to FUEL TANK REMOVAL in the appropriate section (Carbureted or EFI Engine) of the Service Manual.

CAUTION

Direct contact of D.O.T. 5 brake fluid with eyes can cause eye irritation, swelling, and redness. Avoid eye contact. In case of eye contact flush with large amounts of water and get medical attention. Swallowing large amounts of D.O.T. 5 brake fluid can cause digestive discomfort. If swallowed, obtain medical attention. Use in well ventilated area. KEEP OUT OF REACH OF CHILDREN. (00144a)

CAUTION

Direct contact of D.O.T. 4 brake fluid with eyes can cause irritation. Avoid eye contact. In case of eye contact flush with large amounts of water and get medical attention. Swallowing large amounts of D.O.T. 4 brake fluid can cause digestive discomfort. If swallowed, obtain medical attention. Use in well ventilated area. KEEP OUT OF REACH OF CHILDREN. (00240a)

NOTICE

D.O.T. 4 brake fluid will damage painted and body panel surfaces it comes in contact with. Always use caution and protect surfaces from spills whenever brake work is performed. Failure to comply can result in cosmetic damage. (00239b)

- If DOT 4 brake fluid contacts painted surfaces, IMMEDIATELY flush area with clear water.

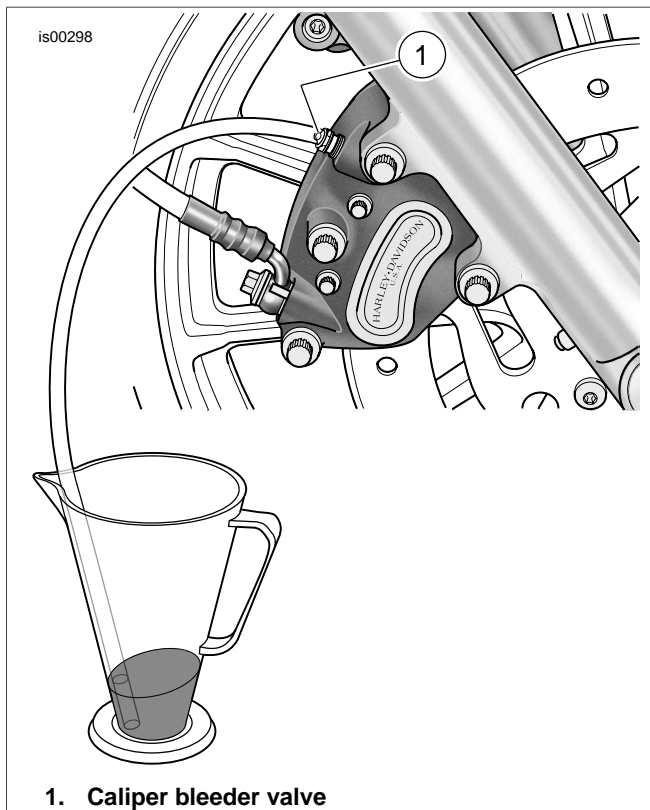

Figure 1. Draining Brake Fluid

3. Bleed the brake fluid from the front brake.
See Figure 1. Open the bleeder screw cap on the front brake caliper. Obtain a length of plastic tubing. Install one end of the tubing over the caliper bleeder screw. Place the free end of the tubing into a suitable container.
4. Open the bleeder screw about one-half turn and pump the front-brake hand lever to drain the fluid out of the front brake system. Do not reuse brake fluid.

Original Handlebar Removal

NOTE

Cover painted parts to protect finish.

NOTICE

Remove brake line components carefully. Damage to seating surfaces can cause leakage. (00320a)

1. Carefully record the front brake line routing and the orientation of the banjo fittings. Disconnect the brake line from the front brake caliper and the front brake master cylinder assembly. Save the banjo bolts, but discard the two sealing

gaskets found at each banjo fitting. See FRONT BRAKE MASTER CYLINDER in the Service Manual.

2. Remove the old brake line.

NOTE

For models with handlebar-mounted turn signals, remove the plastic wiring retainer clips that secure the turn signal harnesses to the handlebar.

3. Using a T27 TORX® drive head, remove the front-brake master cylinder and clutch-lever assemblies from the handlebar.
4. Refer to CLUTCH HAND CONTROL: REMOVAL in the Service Manual, and follow the instructions to disconnect the clutch cable from the clutch lever.

If the clutch cable is being replaced, disconnect the clutch cable from the side cover. Remove the cable from the vehicle.

NOTE

Record wire routing and cable strap locations before removal.

5. Disconnect the handlebar control wiring from the gray and black 6-way main harness connectors under the fuel tank.

NOTE

Before disconnecting the turn signal wiring, note turn signal wire routing.

6. For vehicles with handlebar-mounted turn signals, separate the 6-way turn signal connector halves.
7. Refer to HANDLEBAR SWITCHES: RIGHT HANDLEBAR CONTROLS section of the Service Manual for removal of the right side switch housing assembly and harness.
8. Refer to the THROTTLE CONTROL section of the Service Manual to disconnect the throttle cables or the electronic twist grip sensor from the existing right grip/throttle sleeve assembly.
9. Refer to the LEFT HANDLEBAR CONTROLS section of the Service Manual for removal of the left side switch housing assembly and wire harness.
10. See Figure 2. Remove and discard the 4 hex socket head screws (1) that fasten the handlebar upper clamp (2) to the risers (3). Discard the clamp. Remove the handlebar (4).
11. If the left side hand grip is not glued to the handlebar: Remove the hand grip and set it aside for installation to the new handlebar.

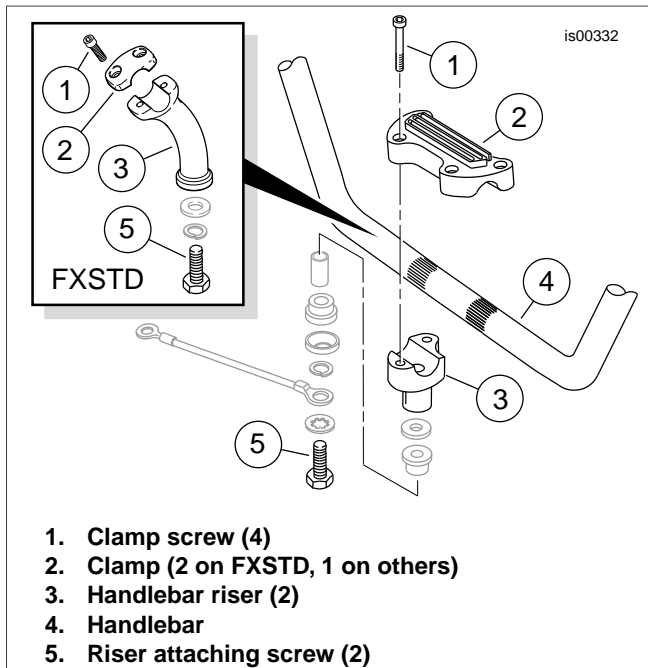

Figure 2. Handlebar Clamps and Risers

NOTE

Record the installed sequence of the riser attaching hardware to verify correct reassembly.

12. Remove and discard the stock handlebar risers. Save the remaining hardware for later installation.

NOTES

JAE connectors are used on handlebar control wiring for 2011 and newer models. Molex connectors are used for the handlebar control wiring on 2007 through 2010. 2006 and earlier vehicles use Deutsch connectors. Refer to the ELECTRICAL CONNECTORS section of the Service Manual for reconnection procedures.

DO NOT remove the wires from the Molex or Deutsch handlebar switch connector **pin housings** under the fuel tank.

Models with handlebar-mounted turn signals: DO NOT remove the wires from the Multilock connector **pin housing** under the fuel tank.

13. Note the wire colors and positions in each cavity of the **socket housings** leading from the switches. Refer to the wiring diagram and the ELECTRICAL CONNECTORS section in the Service Manual. Remove the wires from the socket housings.

Models with handlebar-mounted turn signals: Note the wire colors and positions in each cavity of the Multilock **socket housing** leading from the turn signals. Refer to the wiring diagram and the AMP MULTILOCK ELECTRICAL CONNECTORS section in the Service Manual. Remove the wires from the socket housing.

14. Use tape to wrap the wire terminal ends **from each source** to make separate leaders. Wrap each leader tight enough to enter the grommet hole and pass easily through the **new** handlebar.

New Handlebar Wiring

1. Remove the plastic wiring retainer clips that secured both switch harnesses to the original handlebar.

2. See Figure 4. Slide one large grommet (2) onto each of the switch-wire bundles, positioning the grommet close to the switch end.

For models WITHOUT handlebar-mounted turn signals, proceed to Step 7.

For models WITH handlebar-mounted turn signals, slide one small grommet (3) onto each of the turn-signal wire bundles, positioning the grommet close to the turn signal end.

3. Apply a light coat of liquid soap, window cleaner or all-purpose lubricant such as WD-40®, to the right side turn signal wire bundle.
4. Gently feed the right side turn-signal wire leader into the small round grommet hole near the right side end of the new handlebar and toward the large opening in the center of the bar.

WARNING

Wiring in the switch housings must be routed exactly as shown. Pinch points in the switch housings can short-circuit or sever wires, which could cause loss of control resulting in death or serious injury. (00415b)

5. **For 2015 and newer models:** Gently feed the twist grip sensor wire bundle into the right side handlebar end.

See Figure 3. Route the right side switch wire bundle through the switch housing as shown. Gently feed the wire bundle into the right side switch wire hole.

Pull the bundles down through the new handlebar and toward the center of the bar, while fitting the index tabs on the twist grip sensor into the slots on the end of the handlebar. One index tab and slot are smaller than the other to aid in proper assembly.

WARNING

Carefully pull the wires through hole in handlebar to prevent stripping the wires. Stripped wires can cause short circuits and damage vehicle electrical components, which could cause loss of vehicle control resulting in death or serious injury. (00418b)

6. **ALL models:** Pull the taped end of the wire bundle through the wire-exit hole at the center of the handlebar.
7. Repeat Steps 3 through 5 for the left side turn signal wires.
8. Apply a light coat of liquid soap, window cleaner or all-purpose lubricant such as WD-40®, to the right side switch wire bundle.

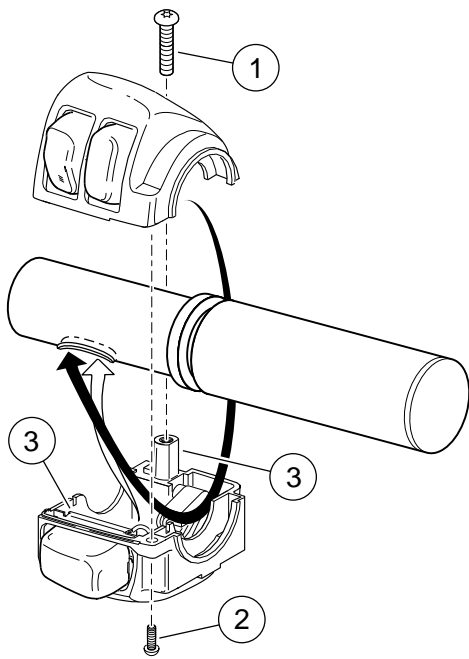

1. Upper switch housing screw
2. Lower switch housing screw
3. Pinch points

Figure 3. Switch-Housing Wire Routing (Right-Side Housing Shown)

⚠ WARNING

Wiring in the switch housings must be routed exactly as shown. Pinch points in the switch housings can short-circuit or sever wires, which could cause loss of control resulting in death or serious injury. (00415b)

9. See Figure 3. Route the switch wire bundle through the switch housing as shown. Gently feed the wire bundle into the oblong switch wire hole near the right side end, and toward the center of the handlebar.
10. Pull the taped end of the switch wire bundle through the wire-exit hole at the center of the handlebar.
11. Repeat Steps 7 through 9 for the left side switch wires.

⚠ WARNING

Grommets in each of the wiring holes in the handlebar must remain in position after routing the wiring through the handlebar. Operation without the grommets in place can damage wires, causing a short circuit which could result in death or serious injury. (00416d)

12. See Figure 4. Insert the switch-wire grommets (2) into place in the switch-wire holes in the handlebar.

NOTE

The round turn-signal wiring grommets are a tight fit. Use a twisting motion to avoid damaging the grommets.

13. **For models with handlebar-mounted turn signals:** Insert the turn-signal grommets (3) into place in the turn-signal wire holes in the handlebar.
14. Loosely fasten the brake-lever and clutch-lever clamps to the new handlebar.

15. Loosely fasten the handlebar switch housings to the new handlebar.
16. See Figure 4:
 - a. Cut each 4 in (102 mm) long piece of heat shrink tubing (4 and 5) from the kit into two equal pieces.
 - b. Slide one piece of the larger diameter tubing (4) over the end of each switch-wire bundle exiting the center hole of the handlebar (1).
 - c. **For models with handlebar-mounted turn signals,** slide one piece of the smaller diameter tubing (5) over the end of each turn-signal wire bundle exiting the center hole of the handlebar.
17. Remove the tape from the ends of the wire bundles.
18. Check for electrical continuity between the handlebar and each wire in the wire bundles. Continuity would indicate a short circuit, which would require examination of the wires and routing in the switch housing.

⚠ WARNING

Wires exiting the bottom center of the handlebar must be protected from wear with heat-shrink tubing at the wire-exit hole on the handlebar. Failure to protect wires with shrink tubing can cause short-circuits or severed wires, which could cause loss of vehicle control resulting in death or serious injury. (00432c)

NOTE

The heat shrink tubing on the wire bundles exiting the bottom center of the handlebar must be installed to protect the wires from damage and short circuits at the wire-exit hole on the handlebar.

19. Position the heat shrink tubing (installed on the wire bundles in Step 15) in the area of the center wire-exit hole on the handlebar.

⚠ WARNING

Be sure to follow manufacturer's instructions when using the UltraTorch UT-100 or any other radiant heating device. Failure to follow manufacturer's instructions can cause a fire, which could result in death or serious injury. (00335a)

- Avoid directing heat toward any fuel system component. Extreme heat can cause fuel ignition/ explosion resulting in death or serious injury.
 - Avoid directing heat toward any electrical system component other than the connectors on which heat shrink work is being performed.
 - Always keep hands away from tool tip area and heat shrink attachment.
20. Use a heat gun or suitable radiant-heating device to shrink the heat shrink tubing to the wire bundles.

New Handlebar Installation

1. See Figure 4. Obtain a **new** Handlebar Riser Kit (A), purchased separately.
2. **FXSTD models only:** Obtain two Riser Mount Spacers (F), purchased separately.

Install the spacers into the bores in the upper fork bracket (triple clamp).

3. **ALL models:** Install the new risers (B) onto the upper fork bracket using the saved hardware in the same sequence as removed. Snug the riser bolts, but do not fully tighten now.
4. Center the new handlebar on the risers. Verify that the knurled areas on the outboard side of each riser are equal.
5. Position **new** handlebar upper clamps (C) with **new** clamp screws (D) and flat washers (E). Snug the upper screws, but do not fully tighten.
6. Route the switch wire bundles down through the large oval opening in the upper fork bracket.
7. Follow the routing noted in the disassembly steps (left switch wire bundle to left side of frame; right switch wire bundle to right side of frame) until the wires reach the switch-wire pin housings. Install any clips or wire guides saved in disassembly.

NOTE

JAE connectors are used on handlebar control wiring for 2011 and newer models. Molex connectors are used for the handlebar control wiring on 2007 through 2010. 2006 and earlier vehicles use Deutsch connectors. Refer to the ELECTRICAL CONNECTORS section of the Service Manual for reconnection procedures.

8. Refer to the notes made during the removal steps, and the wiring diagram and correct ELECTRICAL CONNECTORS section in the Service Manual. Insert each socket terminal from the left side wire bundle into the correct cavity of the **gray** socket housing removed earlier.
9. Insert each socket terminal from the right side wire bundle into the correct cavity of the **black** socket housing removed earlier.

NOTE

Some models require installation of switch wire extensions in order to reach the vehicle harness pin housings under the fuel tank. Refer to the latest Harley-Davidson Genuine Motor Accessories and Genuine Motor Parts catalog for a list of required parts or accessories.

10. Connect the gray socket housing to the gray 6-way pin housing under the left side of the fuel tank. Connect the black socket housing to the black 6-way pin housing under the right side of the tank.
11. **For models with handlebar-mounted turn signals:**
 - a. Route both turn signal wires down through the large oval opening in the center of the upper fork bracket.
 - b. Follow the routing noted earlier to the 6-way turn signal pin housing under the right side of the fuel tank.
 - c. Refer to the notes made during the removal steps, and the wiring diagram and AMP MULTILOCK ELECTRICAL CONNECTORS section in the Service Manual. Insert each socket terminal leading from the turn signals into the correct cavity of the Multilock socket housing removed earlier.
 - d. Install the clips and/ or wire guides saved earlier.
12. Connect the 6-way AMP socket housing to the main harness pin housing under the fuel tank.

WARNING

When servicing the fuel system, do not smoke or allow open flame or sparks in the vicinity. Gasoline is extremely flammable and highly explosive, which could result in death or serious injury. (00330a)

13. Install fuel tank. Refer to FUEL TANK-INSTALLATION in the appropriate section (Carbureted or EFI Engine) of the Service Manual.

NOTICE

Improperly aligned handlebars or components can contact the fuel tank when turned to the left or right. Contact with the fuel tank can cause cosmetic damage. (00372b)

14. Slowly turn handlebar to full left lock and full right lock. If contact occurs and the handlebars are properly centered, raise the handlebar angle as necessary until proper clearance is attained.
15. Tighten the upper handlebar-clamp screws:
 - a. Tighten the front screws until the upper handlebar clamps contact the handlebar riser.
 - b. Tighten the rear screws to 12-16 ft-lbs (16.3-21.7 Nm).
 - c. Tighten the front screws to 12-16 ft-lbs (16.3-21.7 Nm).

NOTE

There will be a slight gap between the upper clamps and the risers toward the rear of the handlebars after tightening.

16. One at a time, remove the riser bolts installed in Step 3. Apply two drops of Loctite® 271 (Red) to the bolt threads. Tighten the riser bolts to 25-30 ft-lbs (34-41 Nm).
17. Refer to RIGHT HANDLEBAR SWITCH: INSTALLATION in the Service Manual. Follow the instructions given to install the throttle control cables and a new (purchased separately) or original right grip/ throttle sleeve assembly.
18. Adjust the position of the switch housing and the brake lever assembly on the handlebar for rider comfort and posture. The brake master cylinder must be horizontally level.

NOTE

*Tighten the top **brake lever clamp** screw before tightening the bottom screw.*

19. Use a T27 TORX drive head to tighten first the top screw. Then the bottom brake-lever clamp screws to 71-80 **in-lbs** (8.0-9.0 Nm).

NOTE

Tighten the lower switch housing screw before tightening the upper screw. This leaves any gap in the switch housing at the front for best appearance.

20. Use a T25 TORX drive head to tighten first the lower. Then tighten the upper **switch housing** screws. Tighten screws to 35-45 **in-lbs** (4.0-5.1 Nm).
21. Verify that the right grip/ throttle sleeve rotates and returns freely not binding on the handlebar or switch housing.

NOTE

If the handlebar grips are patterned, align the pattern on the left grip with the pattern on the right grip while the throttle is in the fully closed position.

22. Install a new (purchased separately) or original handlebar grip on the left end of the new handlebar according to the handlebar grip instruction sheet or LEFT HAND GRIP, INSTALLATION instructions in the Service Manual.
23. Refer to LEFT HANDLEBAR SWITCH: INSTALLATION in the Service Manual. Adjust the positions of the switch housing and the clutch lever assembly on the handlebar for rider comfort and posture.
24. Use a T27 TORX drive head to tighten first the top screw. Then the bottom clutch-lever clamp screws. Tighten screws to 71-80 **in-lbs** (8.0-9.0 Nm).
25. Use a T25 TORX drive head to tighten first the lower screw. Then the upper **switch housing** screws. Tighten to 35-45 **in-lbs** (4.0-5.1 Nm).

FINAL ASSEMBLY

WARNING

Replace brake line gaskets. Re-using original gaskets can cause brake failure and loss of vehicle control, which could result in death or serious injury. (00318a)

NOTICE

Avoid leakage. Be sure gaskets, banjo bolt(s), brake line and caliper bore are clean and undamaged before assembly. (00321a)

1. Carefully inspect the **new** brake line (sold separately) for damage or defects, and replace if damaged. Install per the instructions included with the brake line.
2. Bleed the brakes. See BLEEDING HYDRAULIC BRAKES in the Service Manual.
3. Install the clutch cable to the clutch lever or install a **new** clutch cable (sold separately) per the CLUTCH HAND CONTROL instructions in the Service Manual.

SAFETY CHECK

WARNING

Be sure that steering is smooth and free without interference. Interference with steering could result in loss of vehicle control and death or serious injury. (00371a)

- Verify wires, clutch cables, throttle/ idle cables and brake lines do not pull tight when handlebars are turned fully to left or right fork stops.

WARNING

Connect positive (+) battery cable first. If positive (+) cable should contact ground with negative (-) cable connected, the resulting sparks can cause a battery explosion, which could result in death or serious injury. (00068a)

1. Verify that the Ignition/ Light Key Switch is turned to OFF. Apply a light coat of petroleum jelly or corrosion retardant material to battery terminals. Refer to the Service Manual and follow the instructions given to reattach the battery cables (positive cable first).

WARNING

Be sure that all lights and switches operate properly before operating motorcycle. Low visibility of rider can result in death or serious injury. (00316a)

2. Turn the Ignition/Light Key Switch to IGNITION, but do not start the motorcycle. Test all switches and lights for proper operation.
3. Turn the handlebar to the left and right steering stops, testing the handlebar control functions at each stop.
4. Apply the front brake hand lever to test operation of the brake lamp.
5. Refer to the Service Manual, and follow instructions to install the seat.

WARNING

After installing seat, pull upward on seat to be sure it is locked in position. While riding, a loose seat can shift causing loss of control, which could result in death or serious injury. (00070b)

WARNING

Before starting engine, be sure throttle control will snap back to idle position when released. A throttle control that prevents engine from automatically returning to idle can lead to loss of control, which could result in death or serious injury. (00390a)

WARNING

After repairing the brake system, test brakes at low speed. If brakes are not operating properly, testing at high speeds can cause loss of control, which could result in death or serious injury. (00289a)

SERVICE PARTS

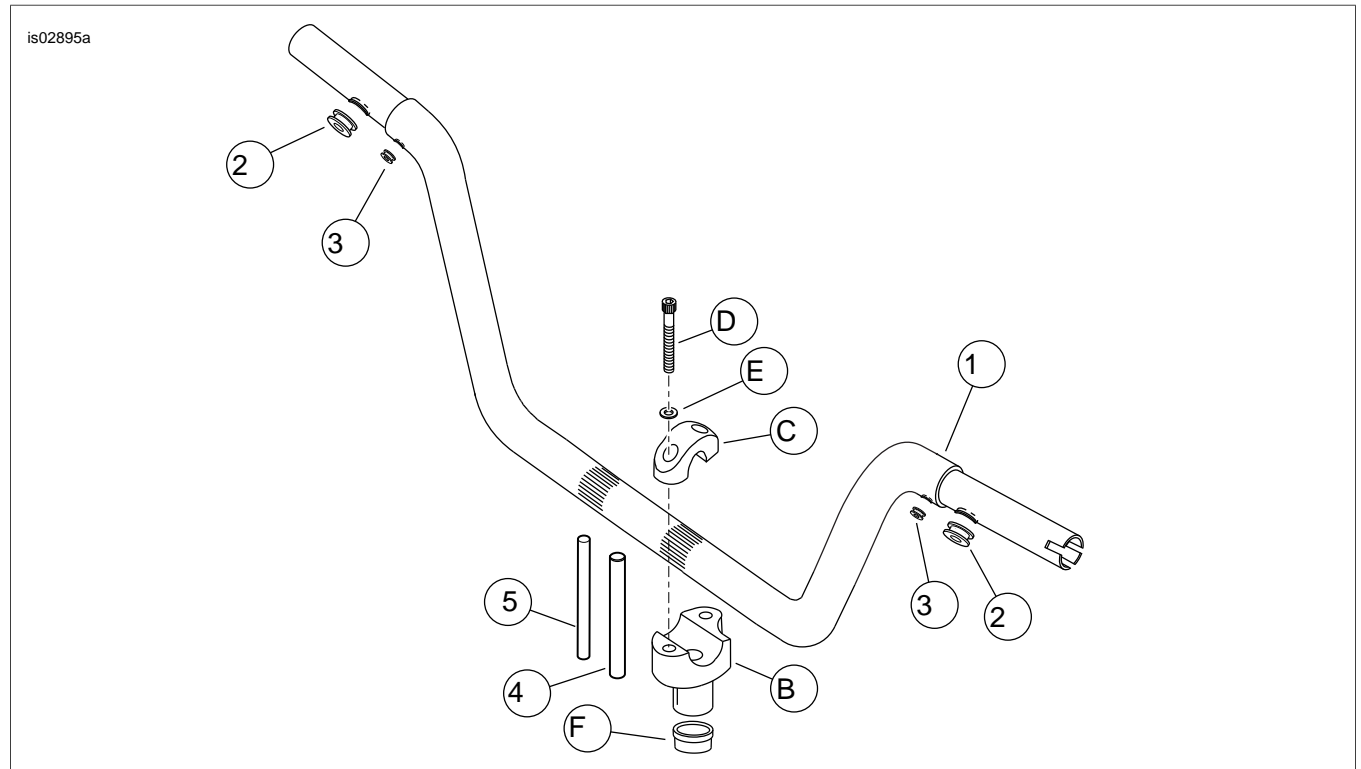

Figure 4. Service Parts

Table 1. Service Parts Table

Item	Description (Quantity)	Part Number
1	Handlebar	Not sold separately
2	Handlebar grommet, large (2)	11403A
3	Handlebar grommet, small (2)	11398
4	Heat-shrink tube, large	72162-02
5	Heat-shrink tube, small	72165-02
Items mentioned in text, but not included in kit:		
A	Riser Kit (includes items B through E)	
B	• Handlebar riser (2)	
C	• Clamp, handlebar riser (2)	
D	• Riser mounting screw (4)	
E	• Washer (4)	
F	Mount spacer (2, FXSTD models only)	