

PERFORMANCE • TECHNICAL SPECIFICATIONS

PFM 10.2 PFM 12.2 PFM 15.2 PFM 15.3 PFM 15.2MA PFM 12.2MA PFM 8MA PFM 15S

LOUDSPEAKER SPECIFICATIONS

COMPONENTS	High	Niobium horn tweeter with polycarbonate diaphragm							
	Mid	6" midrange				8" wide-range			
	Low	10" woofer	12" woofer	15" woofer	15" woofer	15" woofer	12" woofer		15" woofer
POWER HANDLING (EIA RS-426A)	<i>W continuous</i>	100	150	250	250	250	150	100	350
	<i>W peak</i>	200	300	500	500	500	200	200	700
IMPEDANCE	<i>Ohms</i>	8	8	4 / 8	4 / 8				8
PASSIVE CROSSOVER	<i>Hz</i>	5 kHz 6 dB/oct.	5 kHz 6 dB/oct.	4 kHz 6 dB/oct.	0.8/ 5 kHz 12 / 6 dB/oct.	4 kHz 6 dB/oct.	5 kHz 6 dB/oct.		230 Hz 12 / 6 dB/oct.
CONNECTIONS (passive versions)		2 x JACK (input + link)						3 x JACK (input + link + out)	
CONSTRUCTION		Chipboard covered with blue carpet							
DIMENSIONS	<i>mm (WxHxD)</i>	340x458x285	390x508x325	458x578x405	482x608x405	460x580x410	390x508x325	305x395x275	478x508x478
WEIGHT (passive / active)	<i>kg</i>	9 / 12	11.5 / 15.5	16.5 / 21.5	19.5 / 24.5	21.5	15	11.5	19.5 / 24.5

AMPLIFIER SPECIFICATIONS (active versions)

EIA OUTPUT POWER (1kHz, max THD 1%)	<i>W</i>	100	150	250	230 + 80	250	150	100	350
INPUT SENSITIVITY	<i>dB (V)</i>	0 (0.775V)							
INPUT IMPEDANCE	<i>kohms</i>	30 (balanced) - 15 (unbalanced)							
ACTIVE CROSSOVER	<i>Hz</i>	2 kHz 18 dB/oct.				From 80 to 320 @ 12db/oct.			
DISTORSION	<i>%</i>	<0.02 (THD+Noise)							
CONTROLS		Volume - Shield on/off						Volume - Shield on/off XOVER frequency	
CONNECTIONS		XLR-F + JACK (input + link)						JACK + XLR-F (in) JACK + XLR-M (out)	
POWER SUPPLY		See label on the apparatus							

SYSTEM SPECIFICATIONS

SENSITIVITY (SPL 1W/1m)	<i>dB</i>	96	97	98	98	98	97	95	94
MAX SPL continuous	<i>dB</i>	113	116	119	121	119	116	114	118
MAX SPL peak	<i>dB</i>	116	119	122	127	122	119	117	121
FREQUENCY RESPONSE	<i>Hz (-10dB)</i>	60 - 20k	55 - 20k	48 - 20k	45 - 20k	48 - 20k	55 - 20k	65 - 20k	40 - 300
DISPERSION (OxV)	<i>°</i>	90 x 60	90 x 60	90 x 60	90 x 60	90 x 60	90 x 60	90 x 90	

Transistor Packages

TO92 BC547, BC557: 1=Collector 2=Base 3=Emitter	TO126 MJE340, MJE350, MJE802: 1=Emitter 2=Collector 3=Base 4=Collector	TO220 TIP41C, TIP42C: 1=Base 2=Collector 3=Emitter 4=Collector	TO3P 2SC3284, 2SA1303: 1=Base 2=Collector 3=Emitter 4=Collector
---	---	---	--

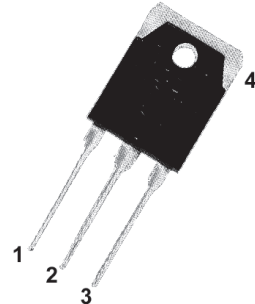
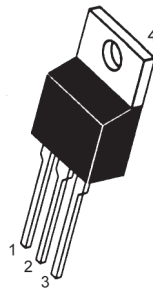
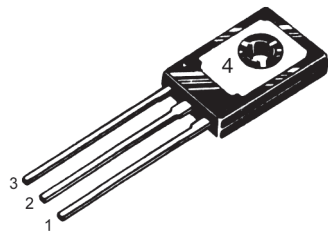
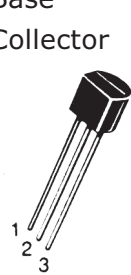

PFM10X 8ohm

SPECIFICATION	
WAYS	2
XOVER FREQ.	5KHz
SLOPE HP	6dB/Oct.
POWER rms	100W
POWER max	200W
IMPEDANCE (nominal)	8ohm

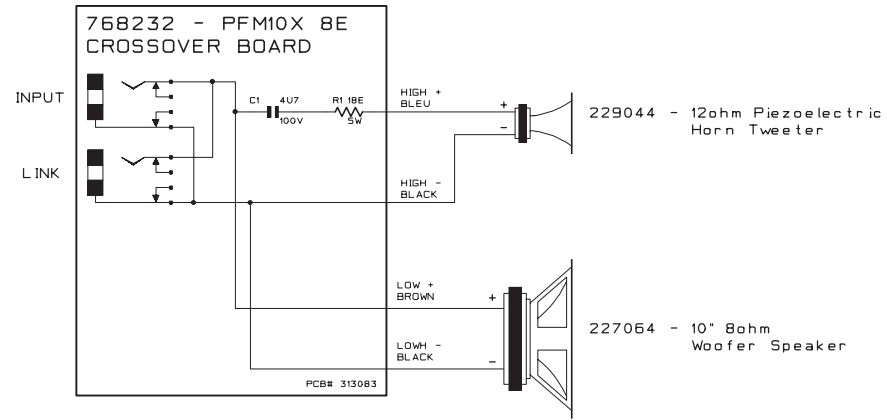

PFM15.2 8ohm

SPECIFICATION	
WAYS	2
XOVER FREQ.	4KHz
SLOPE HP	6dB/Oct.
POWER rms	250W
POWER max	500W
IMPEDANCE (nominal)	8ohm

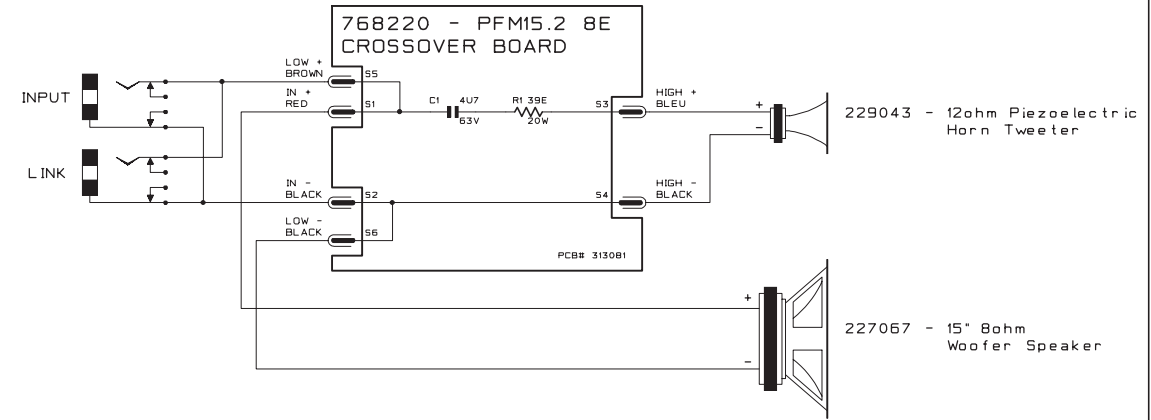

PFM10.2 8ohm

SPECIFICATION	
WAYS	2
XOVER FREQ.	5KHz
SLOPE HP	6dB/Oct.
POWER rms	100W
POWER max	200W
IMPEDANCE (nominal)	8ohm

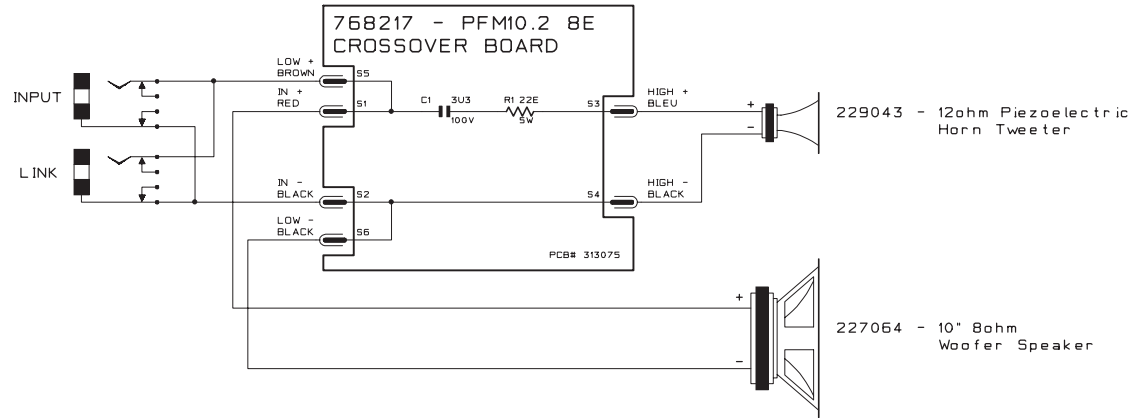

PFM15.3 4ohm

SPECIFICATION	
WAYS	3
XOVER FREQ.	800Hz-5KHz
SLOPE HP	12-6dB/Oct.
POWER rms	250W
POWER max	500W
IMPEDANCE (nominal)	4ohm

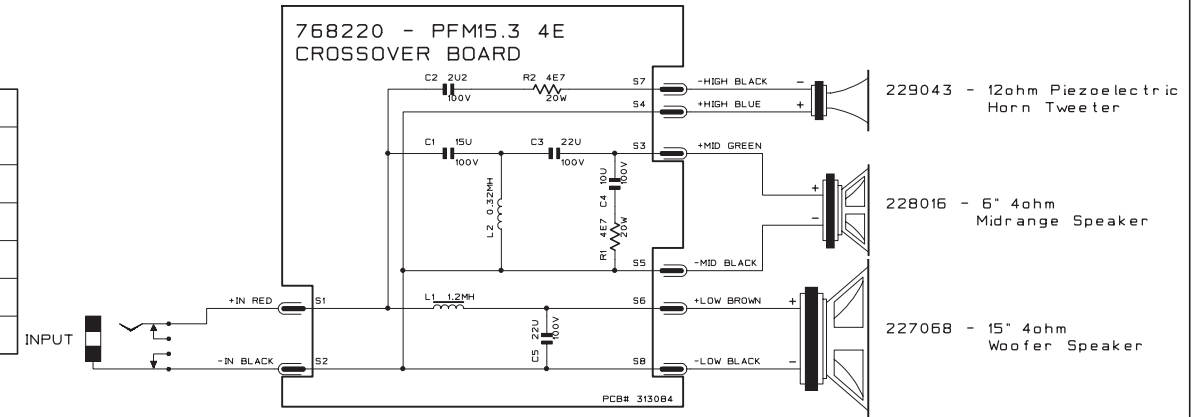

PFM12.2 8ohm

SPECIFICATION	
WAYS	2
XOVER FREQ.	5KHz
SLOPE HP	6dB/Oct.
POWER rms	150W
POWER max	300W
IMPEDANCE (nominal)	8ohm

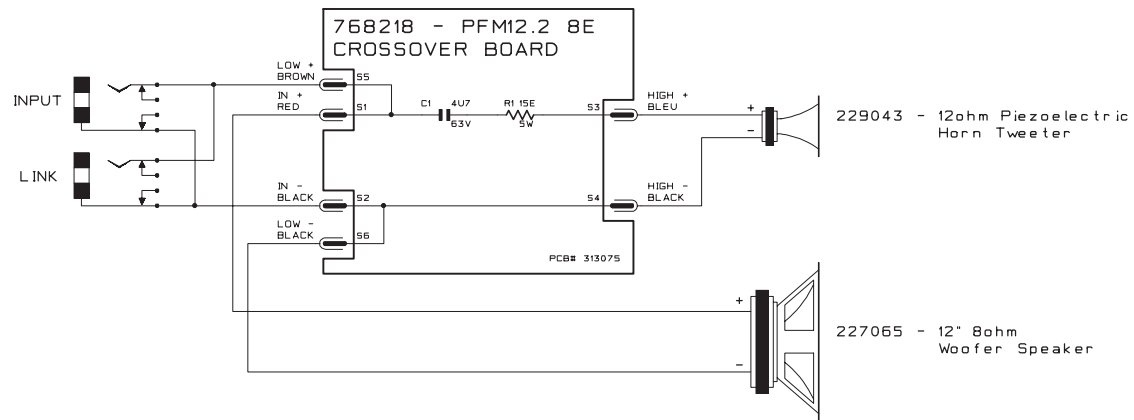

PFM15.3 8ohm

SPECIFICATION	
WAYS	3
XOVER FREQ.	800Hz-5KHz
SLOPE	12-6dB/Oct.
POWER rms	250W
POWER max	500W
IMPEDANCE (nominal)	8ohm

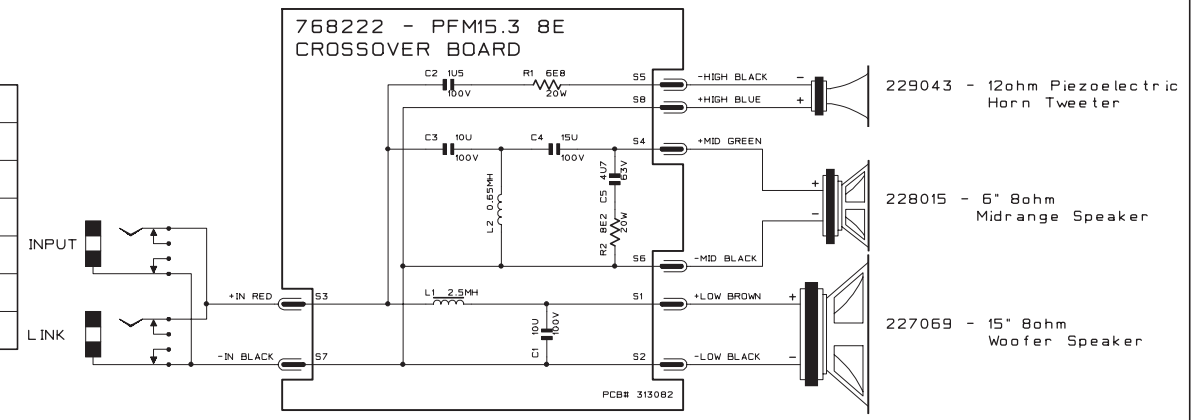

PFM15.2 4ohm

SPECIFICATION	
WAYS	2
XOVER FREQ.	4KHz
SLOPE HP	6dB/Oct.
POWER rms	250W
POWER max	500W
IMPEDANCE (nominal)	4ohm

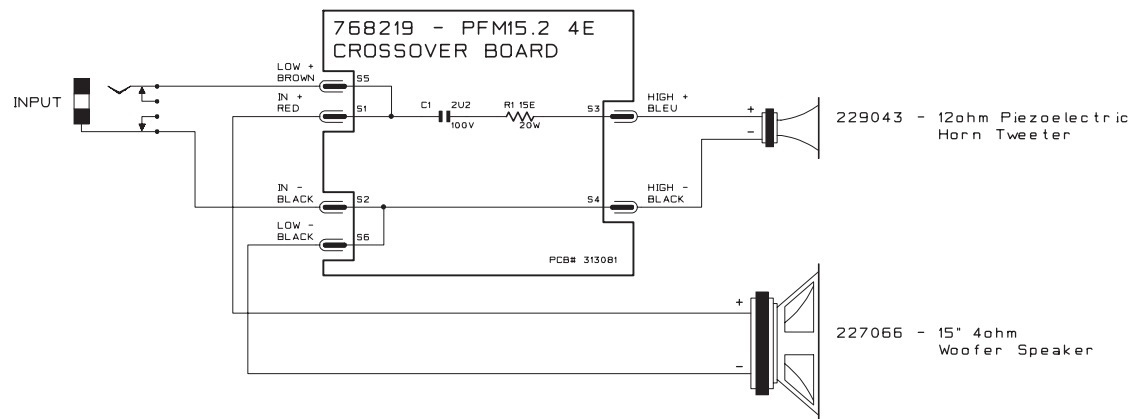

PFM15S 4ohm

SPECIFICATION	
WAYS	1
XOVER FREQ.	230Hz
SLOPE HP	12-6dB/Oct.
POWER rms	350W
POWER max	700W
IMPEDANCE (nominal)	4ohm

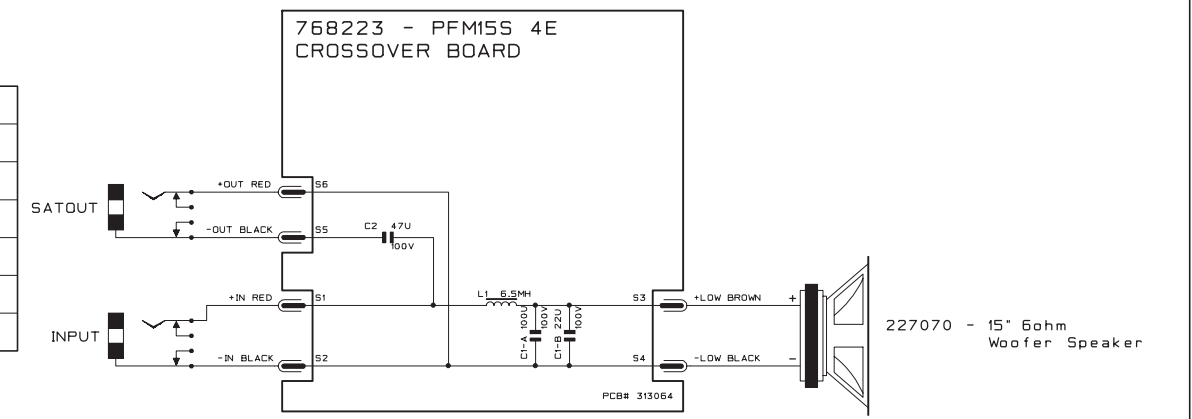

PFM155A - AMPLIFIED SUBWOOFER SPEAKER - BLOCK DIAGRAM

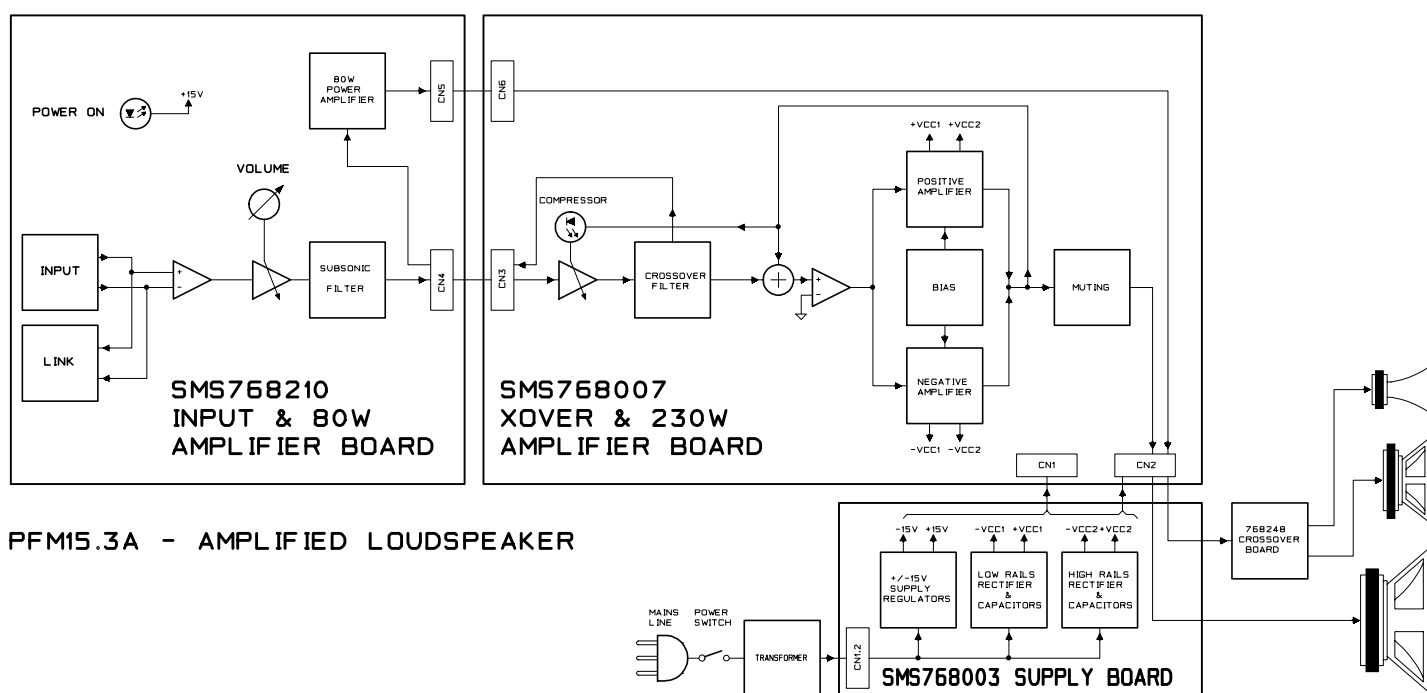
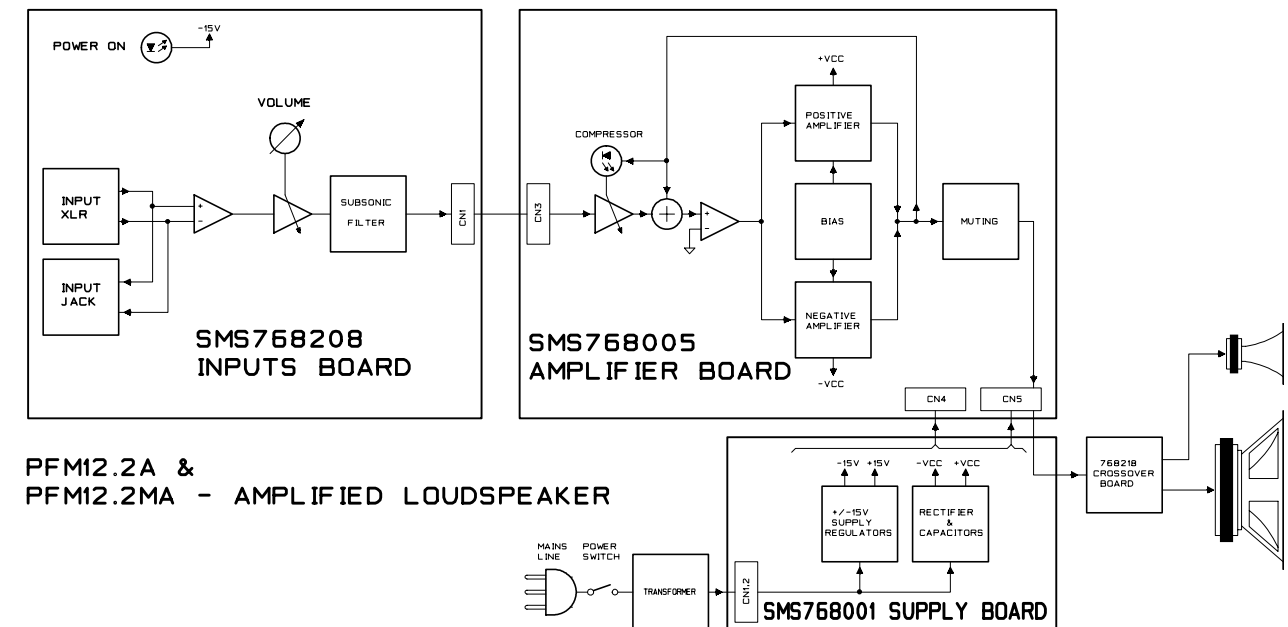
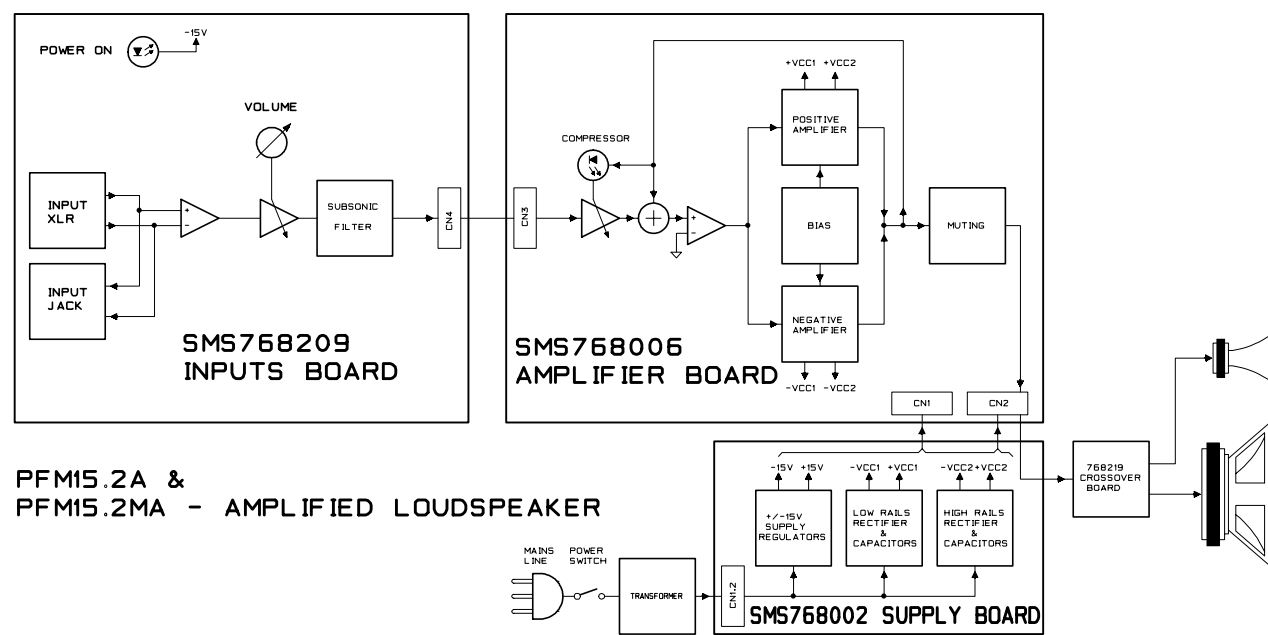
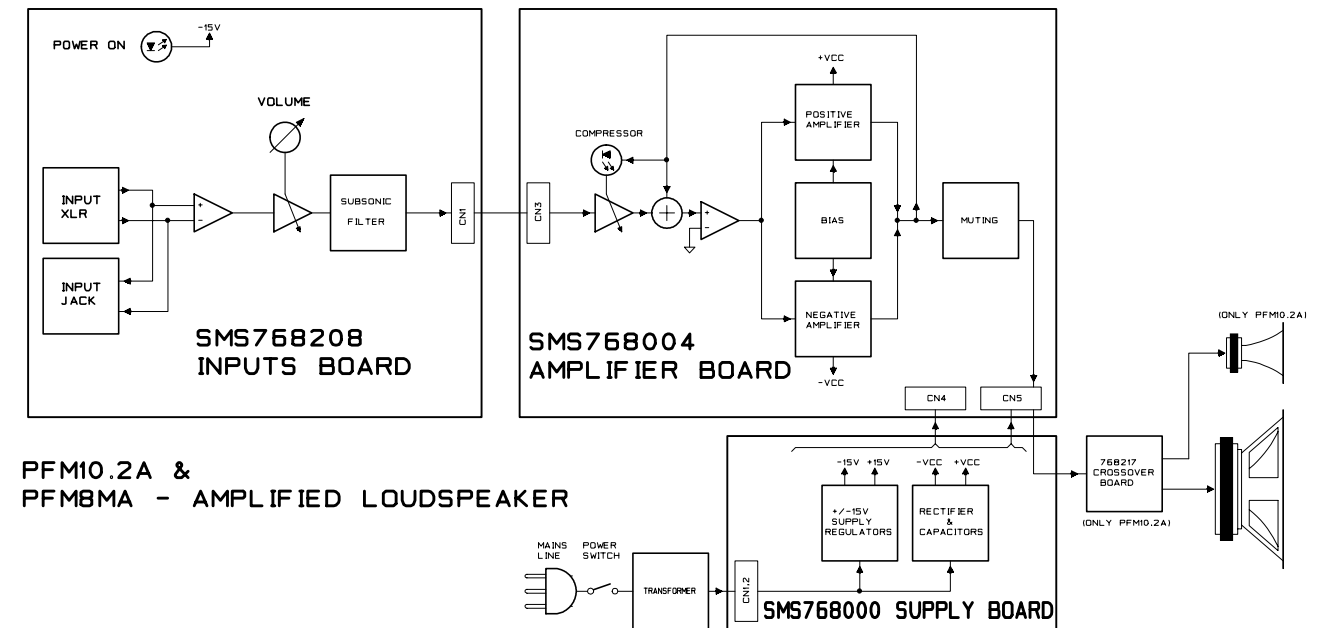
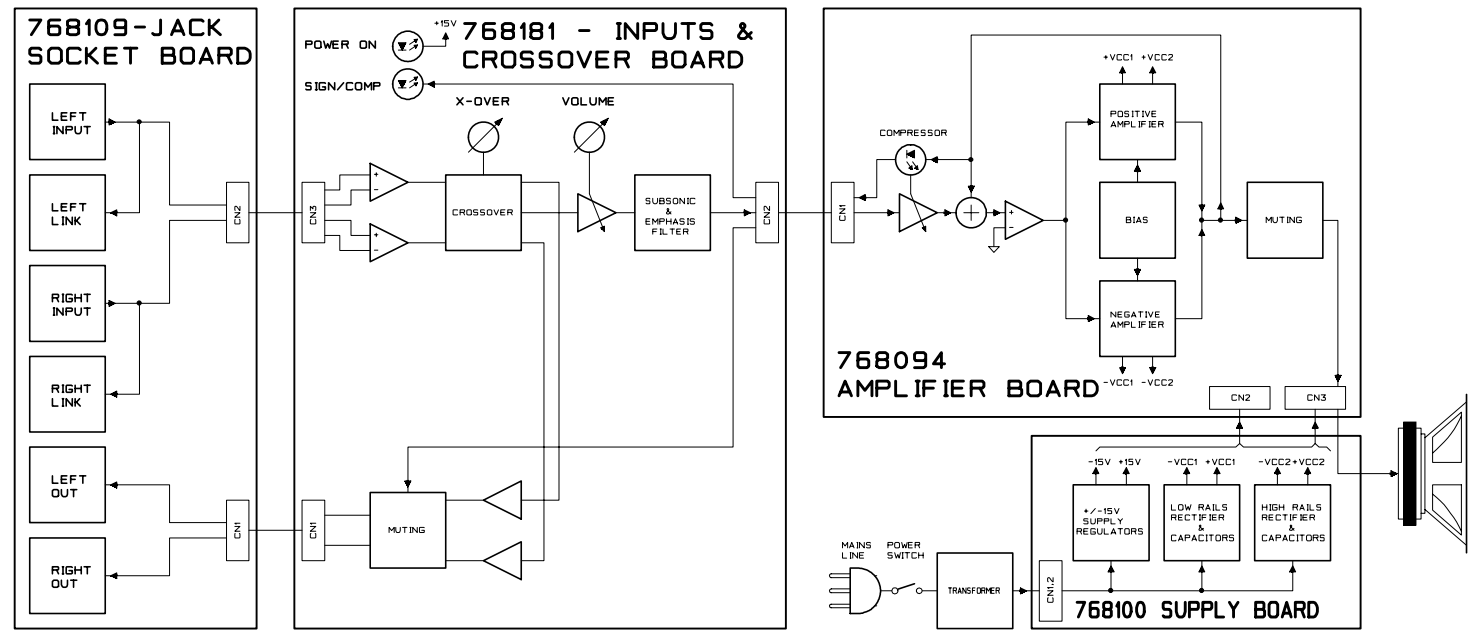

DRW G.BOCCATO	DWG# 550652	PCB#	GENERALMUSIC S.p.A. ITALY
CKD G.RICCI	DSK# 6 PART: 1/1	SCHEMATIC DIAGRAM PFM SERIES ACTIVE	ALL RIGHTS ARE RESERVED. NO COPIES OR REPRODUCTIONS WITHOUT WRITTEN CONSENT BY GENERALMUSIC.
APP. R.FALCONI	REV: 09/10/00	BLOCK DIAGRAMS	

TEST PROCEDURES & ADJUSTMENTS

These procedures are relative to the ACTIVE versions (amplified loudspeakers) only.

Precaution

- ⚡ To prevent short circuit during any test, **the oscilloscope must be EARTH insulated**, this occurs because some test require to connect its probe to the amplifier output, non-compliance may cause damages to oscilloscope inputs circuitry.
- ⚡ Before removing or installing any modules and connectors, **disconnect the amplifier from AC MAINS** and measure the DC supply voltages across each of the power supply capacitors. If your measurement on any of the caps is greater than 10Vdc, connect a 100Ω 10W resistor across the applicable caps to discharge them for your safety. Remember to remove the discharge resistor immediately after discharging caps. **Do not power up the amplifier with the discharge resistor connected.**
- ⚡ Read these notes entirely before proceeding to any operation. These notes are not comprehensive of all damages that possibly occur, but includes some specifically advices, checks and adjustments relative to this amplified speaker.
- ⚡ **Do not check the amplifier with the speaker connected use only an appropriate load resistor.**

Visual Check

- ⚡ Check the speakers for any damaging (cone-breaking, interruption or so).
- ⚡ Before proceed to supply the amplifier check visually the internal assembly, if appears an evident damage find the most possible reasons that cause it.
- ⚡ Check the wiring cables for possible interruptions or shorts.
- ⚡ If the damage has burnt a printed circuit board don't try to repair it, replace with a new one.

Test Instruments

- ⚡ Audio Generator
- ⚡ Dual Trace Oscilloscope
- ⚡ Digital Multimeter
- ⚡ Temperature Meter
- ⚡ 8Ω 500W, 4Ω 500W, 100Ω 10W resistors
- ⚡ Variac (0÷250Vac)

PFM10.2A-PFM8MA Amplified Loudspeaker

The following adjustment and notes are relative to these models only.

Technical Specifications

Dimensions:	PFM10.2A (WxHxD)	340x458x285mm
Dimensions:	PFM8MA (WxHxD)	305x395x275mm
Weight:	PFM10.2A	12Kg
Weight:	PFM8MA	11.5Kg
Power Requirements:	(230Vac±10% 50Hz)	150VA

	(115Vac±10% 50/60Hz)	150VA
Output Power*:	(8Ω)	90W
Max.Undistorted Out*:	(8Ω)	76Vpp
Sensitivity:	PFM10.2A (1W/1m)	96dB _{SPL}
Sensitivity:	PFM8MA (1W/1m)	95dB _{SPL}
Max SPL:	PFM10.2A (continuous)	113dB _{SPL}
	PFM10.2A (peak)	116dB _{SPL}
Max SPL:	PFM8MA (continuous)	114dB _{SPL}
	PFM8MA (peak)	117dB _{SPL}
Frequency Response	(amplifier+speaker)	60Hz÷20kHz
	(only amplifier -3dB)	10Hz÷60kHz
Input Sensitivity:	(0dB)	0.775V _{RMS}
Input Impedance:	(balanced)	30KΩ
	(unbalanced)	15KΩ
Voltage Gain:		31±1dB
IMD:	(SMPTE 60Hz/7KHz 4:1)	<0.1%
THD:	(THD+N)	<0.1%
S/N Ratio:	(unweighted)	>100dB

*Note: measured with the limiter enabled.

Setup

- ⚡ Connect the Variac between the mains and the amplifier and set it at zero voltage.
- ⚡ Connect the audio generator to the channel input and set it to 1kHz 775mV_{RMS} (0dB) sinusoidal signal.
- ⚡ Place the temperature sensor between heatsink and the PTC (TH1).
- ⚡ Connect the CH1 scope GND clip to CN4 pin 1 (SGND terminal) and the probe tip to R50 side RL1 (PWR out), set it to 20V/div. 1mS/div.
- ⚡ Connect the CH2 probe tip to R58 side C28 and set its sensitivity at 0.2V/div.
- ⚡ Set the LEVEL potentiometer full clockwise.
- ⚡ The load resistor is disconnected.
- ⚡ The procedures that follow must be executed subsequently in the order specified.

Supply Check

- ⚡ Remove the transformer secondary fuses (located on SUPPLY board), set the Variac to the nominal mains voltage, check with the Multimeter the AC supply voltages:
F1-F2=71±2Vac
- ⚡ Re-set the Variac at zero voltage, turn off the amplifier and put the fuses back on its holders.
- ⚡ Set up the Variac slowly monitoring the Outputs with the oscilloscope CH1 connected, it should display the sinusoidal input signal amplified with no distortions, if a distortion occur or the protection trips, turn off the amplifier and check the AMPLIFIER board as suggested in the ADVICES section.
- ⚡ Finally verify the DC supplies on SUPPLY board:
CN4 pin 2 (+Vcc1) =+50±2Vdc
CN5 pin 1-2 (-Vcc1) =-50±2Vdc
CN4 pin 4 =+15±1Vdc
CN4 pin 5 =-15±1Vdc

- ⚡ If one or more voltages don't correspond, check the rectifiers, capacitors and transformers disconnecting them from circuitry, refer to schematics.

Channel Check

- ⚡ Verify, with the Multimeter, the insulation between the heatsink and the transistors collectors.
- ⚡ Verify, with the Multimeter, the PTC resistor value (TH1), it must be between 50Ω and 200Ω.
- ⚡ **VOLTAGE AMPLIFIER TEST:**
Increase slowly the Variac. The channel output signals must be symmetrical respect the GND without visible distortion and oscillation. If there is a distortion read the section ADVICES.
- ⚡ **CURRENT AMPLIFIER TEST:**
Connect the 8Ω 500W load on the output and repeat the test.
- ⚡ **LIMITER CHECK:**
Increase the input signal of 10 dB and verify the output voltage and wave shape remain constant.
- ⚡ **BIAS ADJUSTMENT:**
With resistive load connected wait until the temperature reach 50°C. Set the generator level at zero, connect the Multimeter across the R50 and R53 resistors, then adjust VR1 trimmer to read 5±0.1mVdc.
- ⚡ **BANDWIDTH CHECK:**
Switch alternatively the generator frequency to 100Hz and 10kHz, no level changes must be detectable respect 1kHz.
Switch the generator frequency to 30Hz and verify the output level decreases about 4.5dB, respect to 1 KHz level.
- ⚡ **OFFSET SENSOR CHECK:**
Set the Variac to zero voltage output, disconnect resistive load from the amplifier output, connect temporarily (by means of a suitable conductor wire) CN4 pin 4 (+15Vdc) to R72 side RL1, the protection circuitry (Q14,15,16) detect the DC voltage and open the output relay (RL1) within 3 seconds approx.
Remove the connection, wait until the relay switch on and after some seconds repeat the check with -15Vdc (available on CN4 pin 5), the protection circuitry must open the relay again.
- ⚡ **SIGNAL TO NOISE RATIO CHECK:**
Disconnect the audio generator and short the input (pin 1,2,3 of XLR socket shorted) the output signal (noise) must be less than 1mV.

PFM12.2A-PFM12.2MA Amplified Loudspeaker

The following adjustment and notes are relative to these models only.

Technical Specifications

Dimensions:	PFM12.2A (WxHxD)	390x508x325mm
Dimensions:	PFM12.2MA (WxHxD)	390x508x325mm
Weight:	PFM12.2A	15.5Kg
Weight:	PFM12.2MA	15Kg
Power Requirements:	(230Vac±10% 50Hz)	180VA
	(115Vac±10% 50/60Hz)	180VA
Output Power*:	(8Ω)	136W
Max.Undistorted Out*:	(8Ω)	93Vpp

Sensitivity:	(1W/1m)	97dB _{SPL}
Max SPL:	(continuous)	116dB _{SPL}
	(peak)	119dB _{SPL}
Frequency Response	(amplifier+speaker)	55Hz÷20kHz
	(only amplifier -3dB)	10Hz÷60kHz
Input Sensitivity:	(0dB)	0.775V _{RMS}
Input Impedance:	(balanced)	30KΩ
	(unbalanced)	15KΩ
Voltage Gain:		33±1dB
IMD:	(SMPTE 60Hz/7KHz 4:1)	<0.1%
THD:	(THD+N)	<0.1%
S/N Ratio:	(unweighted)	>100dB

*Note: measured with the limiter enabled.

Setup

- Connect the Variac between the mains and the amplifier and set it at zero voltage.
- Connect the audio generator to the channel input and set it to 1kHz 775mV_{RMS} (0dB) sinusoidal signal.
- Place the temperature sensor between heatsink and the PTC (TH1).
- Connect the CH1 scope GND clip to CN4 pin 1 (SGND terminal) and the probe tip to R50 side RL1 (PWR out), set it to 20V/div. 1mS/div.
- Connect the CH2 probe tip to R58 side C28 and set its sensitivity at 0.2V/div.
- Set the LEVEL potentiometer full clockwise.
- The load resistor is disconnected.
- The procedures that follow must be executed subsequently in the order specified.

Supply Check

- Remove the transformer secondary fuses (located on SUPPLY board), set the Variac to the nominal mains voltage, check with the Multimeter the AC supply voltages:
F1-F2=90±2Vac
- Re-set the Variac at zero voltage, turn off the amplifier and put the fuses back on its holders.
- Set up the Variac slowly monitoring the Outputs with the oscilloscope CH1 connected, it should display the sinusoidal input signal amplified with no distortions, if a distortion occur or the protection trips, turn off the amplifier and check the AMPLIFIER board as suggested in the ADVICES section.
- Finally verify the DC supplies on SUPPLY board:

CN4 pin 2 (+Vcc1)	=+63±2Vdc
CN5 pin 1-2 (-Vcc1)	=-63±2Vdc
CN4 pin 4	=+15±1Vdc
CN4 pin 5	=-15±1Vdc
- If one or more voltages don't correspond, check the rectifiers, capacitors and transformers disconnecting them from circuitry, refer to schematics.

Channel Check

- Verify, with the Multimeter, the insulation between the heatsink and the transistors collectors.
- Verify, with the Multimeter, the PTC resistor value (TH1), it must be between 50Ω and 200Ω.
- VOLTAGE AMPLIFIER TEST:**
Increase slowly the Variac. The channel output signals must be symmetrical respect the GND without visible distortion and oscillation. If there is a distortion read the section ADVICES.
- CURRENT AMPLIFIER TEST:**
Connect the 8Ω 500W load on the output and repeat the test.
- LIMITER CHECK:**
Increase the input signal of 10 dB and verify the output voltage and wave shape remain constant.
- BIAS ADJUSTMENT:**
With resistive load connected wait until the temperature reach 50°C. Set the generator level at zero, connect the Multimeter across the R50 and R53 resistors, then adjust VR1 trimmer to read 5±0.1mVdc.
- BANDWIDTH CHECK:**
Switch alternatively the generator frequency to 100Hz and 10kHz, no level changes must be detectable respect 1kHz.
Switch the generator frequency to 30Hz and verify the output level decreases about 4.5dB, respect to 1 KHz level.
- OFFSET SENSOR CHECK:**
Set the Variac to zero voltage output, disconnect resistive load from the amplifier output, connect temporarily (by means of a suitable conductor wire) CN4 pin 4 (+15Vdc) to R72 side RL1, the protection circuitry (Q14,15,16) detect the DC voltage and open the output relay (RL1) within 3 seconds approx.
Remove the connection, wait until the relay switch on and after some seconds repeat the check with -15Vdc (available on CN4 pin 5), the protection circuitry must open the relay again.
- SIGNAL TO NOISE RATIO CHECK:**
Disconnect the audio generator and short the input (pin 1,2,3 of XLR socket shorted) the output signal (noise) must be less than 1mV.

PFM15.2A - PFM15.2MA Amplified Loudspeaker

The following adjustment and notes are relative to this model only.

Remarks

- The power supply utilizes a dual bipolar DC rail configuration with low and high voltages; one positive and one negative low rail (+/-Vcc1) and one positive and one negative high rail (+/-Vcc2).

Technical Specifications

Dimensions:	(WxHxD)	458x578x405mm
Weight:		21,5Kg
Power Requirements:	(230Vac±10% 50Hz)	250VA
	(115Vac±10% 50/60Hz)	250VA
Output Power*:	(4Ω)	250W
Max.Undistorted Out*:	(4Ω)	89Vpp
Sensitivity:	(1W/1m)	98dB _{SPL}

Max SPL:	(continuous)	119dB _{SPL}
	(peak)	122dB _{SPL}
Frequency Response	(amplifier+speaker)	48Hz÷20kHz
	(only amplifier -3dB)	10Hz÷60kHz
Input Sensitivity:	(0dB)	0.775V _{RMS}
Input Impedance:	(balanced)	30KΩ
	(unbalanced)	15KΩ
Voltage Gain:		32±1dB
IMD:	(SMPTE 60Hz/7KHz 4:1)	<0.1%
THD:	(THD+N)	<0.1%
S/N Ratio:	(unweighted)	>100dB

*Note: measured with the limiter enabled.

Setup

- Connect the Variac between the mains and the amplifier and set it at zero voltage.
- Connect the audio generator to the channel input and set it to 1kHz 775mV_{RMS} (0dB) sinusoidal signal.
- Place the temperature sensor between heatsink and the PTC (TH1).
- Connect the CH1 scope GND clip to CN1 pin 1 (SGND terminal) and the probe tip to R60 side RL1 (PWR out), set it to 20V/div. 1mS/div.
- Connect the CH2 probe tip to D22 cathode and set its sensitivity at 20V/div.
- Set the LEVEL potentiometer full clockwise.
- The load resistor is disconnected.
- The procedures that follow must be executed subsequently in the order specified.

Supply Check

- Remove the transformer secondary fuses (located on SUPPLY board), set the Variac to the nominal mains voltage, check with the Multimeter the AC supply voltages:
F1-F2=90±2Vac
F4-F5=52±1.5Vac
- Re-set the Variac at zero voltage, turn off the amplifier and put the fuses back on its holders.
- Set up the Variac slowly monitoring the Outputs with the oscilloscope CH1 and CH2 connected, it should display the sinusoidal input signal amplified with no distortions, if a distortion occur or the protection trips check the AMPLIFIER board as suggested in the ADVICES section.
- Finally verify the DC supplies on SUPPLY board:

CN1 pin 2 (+Vcc2)	=+63±2Vdc
CN2 pin 3 (+Vcc1)	=+36±1.5Vdc
CN2 pin 1 (-Vcc1)	=-36±1.5Vdc
CN2 pin 2 (-Vcc2)	=-63±2Vdc
CN1 pin 4	=+15±1Vdc
CN1 pin 5	=-15±1Vdc
- If one or more voltages don't correspond, check the rectifiers, capacitors and transformers disconnecting them from circuitry, refer to schematics.

Channel Check

- ⊞ Verify, with the Multimeter, the insulation between the heatsink and the transistors collectors.
- ⊞ Verify, with the Multimeter, the PTC resistor value (TH1), it must be between 50Ω and 200Ω.
- ⊞ **LOW RAIL VOLTAGE AMPLIFICATION TEST:**
Increase slowly the Variac. The channel output signals must be symmetrical respect the GND without visible distortion and oscillation as shown in *Fig.1 Trace A (Trace B shown the amplifier 2nd stage input R58 side C28)*. If there is a distortion read the section ADVICES.
- ⊞ **HIGH RAIL VOLTAGE AMPLIFICATION TEST:**
When the output signal (Positive half-wave) is less than 29Vp the voltage on D22 cathode must remain constant at 35V, when the output signal exceeds 29Vp the voltage must follow the output signal with 6V offset (see *Fig.2 Trace B*), to check the negative high rail connect the probe to D26 anode (see *Fig.2 Trace C*).
- ⊞ **LOAD CURRENT TEST:**
Connect the 4Ω 500W load on the output and repeat the LOW RAIL and HIGH RAIL tests.
- ⊞ **LIMITER CHECK:**
Increase the input signal of 10 dB and verify the output voltage and wave shape remain constant.
- ⊞ **BIAS ADJUSTMENT:**
With resistive load connected wait until the temperature reach 50°C. Set the level at zero, connect the Multimeter across the resistors R60, then adjust VR1 trimmer to read 12±0.1mVdc.
- ⊞ **BANDWIDTH CHECK:**
Switch alternatively the generator frequency to 100Hz and 10kHz, no level changes must be detectable respect 1kHz.
Switch the generator frequency to 30Hz and verify the output level decreases about 4.5dB, respect to 1 KHz level.
- ⊞ **OFFSET SENSOR CHECK:**
Set the Variac to zero voltage output, disconnect resistive load from the amplifier output, connect temporarily (by means of a suitable conductor wire) CN1 pin 4 (+15Vdc) to R72 side RL1, the protection circuitry (Q14,15,16) detect the DC voltage and open the output relay (RL1) within 3 seconds approx.
Remove the connection, wait until the relay switch on and after some seconds repeat the check with -15Vdc (available on CN1 pin 5), the protection circuitry must open the relay again.
- ⊞ **SIGNAL TO NOISE RATIO CHECK:**
Disconnect the audio generator and short the input (pin 1,2,3 of XLR socket shorted) the output signal (noise) must be less than 1mV.

PFMI 5.3A Amplified Loudspeaker

The following adjustment and notes are relative to this model only.

Remarks

- ⊞ This is a bi-amplified speaker, the more powerful amplifier is for the low frequency range (woofer), the less powerful amplifier is for the high frequency range (midrange and tweeter).
- ⊞ The power supply of the first amplifier utilizes a dual bipolar DC rail configuration with low and high voltages; one positive and one

negative low rail (+/-Vcc1) and one positive and one negative high rail (+/-Vcc2). The second amplifier is supplied by means the only low rail (+/-Vcc1).

Technical Specifications

Dimensions:	(WxHxD)	482x608x405mm
Weight:		24.5Kg
Power Requirements:	(230Vac±10% 50Hz)	310VA
	(115Vac±10% 50/60Hz)	310VA
Output Power*:	(4Ω/8Ω)	230W/80W
Max. Undistorted Out*:	(4Ω/8Ω)	85Vpp/71Vpp
Sensitivity:	(1W/1m)	98dB _{SPL}
Max SPL:	(continuous)	121dB _{SPL}
	(peak)	127dB _{SPL}
Frequency Response	(both amps+speakers)	45Hz÷20kHz
	(only amplifiers -3dB)	10Hz÷60kHz
Input Sensitivity:	(0dB)	0.775V _{RMS}
Input Impedance:	(balanced)	30KΩ
	(unbalanced)	15KΩ
Voltage Gain:		32±1dB
IMD:	(SMPTE 60Hz/7KHz 4:1)	<0.1%
THD:	(THD+N)	<0.1%
S/N Ratio:	(unweighted)	>100dB

*Note: measured with the limiter enabled.

Setup

- ⊞ Connect the Variac between the mains and the amplifier and set it at zero voltage.
- ⊞ Connect the audio generator to the channel input and set it to 2kHz 775mV_{RMS} (0dB) sinusoidal signal.
- ⊞ Place the temperature sensor between heatsink and the PTC (TH1).
- ⊞ Connect the CH1 scope GND clip to CN1 pin 1 (SGND terminal) and the probe tip to R60 side RL1 (LF PWR out), set it to 20V/div. 1mS/div.
- ⊞ Connect the CH2 probe tip to R260 side IC202 (HF PWR out) and set its sensitivity at 20V/div.
- ⊞ Set the LEVEL potentiometer full clockwise.
- ⊞ The load resistor is disconnected.
- ⊞ The procedures that follow must be executed subsequently in the order specified.

Supply Check

- ⊞ Remove the transformer secondary fuses (located on SUPPLY board), set the Variac to the nominal mains voltage, check with the Multimeter the AC supply voltages:
F1-F2=86±2Vac
F4-F5=62±1.5Vac.
- ⊞ Re-set the Variac at zero voltage, turn off the amplifier and put the fuses back on its holders.
- ⊞ Set up the Variac slowly monitoring the Outputs with the oscilloscope CH1 and CH2 connected, it should display the sinusoidal input signal

amplified with no distortions, if a distortion occur or the protection trips check the AMPLIFIER board as suggested in the ADVICES section.

- ⊞ Finally verify the DC supplies on SUPPLY board:
CN1 pin 2 (+Vcc2) =+60±2Vdc
CN2 pin 3 (+Vcc1) =+43±1.5Vdc
CN2 pin 1 (-Vcc1) =-43±1.5Vdc
CN2 pin 2 (-Vcc2) =-60±2Vdc
CN1 pin 4 =+15±1Vdc
CN1 pin 5 =-15±1Vdc
- ⊞ If one or more voltages don't correspond, check the rectifiers, capacitors and transformers disconnecting them from circuitry, refer to schematics.

Low Frequency Channel Check

- ⊞ Verify, with the Multimeter, the insulation between the heatsink and the transistors collectors.
- ⊞ Verify, with the Multimeter, the PTC resistor value (TH1), it must be between 50Ω and 200Ω.
- ⊞ Set the audio generator to 500Hz 775mV_{RMS} (0dB) sinusoidal signal.
- ⊞ Connect the CH2 probe tip to D22 cathode and set its sensitivity at 20V/div.
- ⊞ **LOW RAIL VOLTAGE AMPLIFICATION TEST:**
Increase slowly the Variac. The channel output signals must be symmetrical respect the GND without visible distortion and oscillation as shown in *Fig.1 Trace A (Trace B shown the amplifier 2nd stage input R58 side C28)*. If there is a distortion read the section ADVICES.
- ⊞ **HIGH RAIL VOLTAGE AMPLIFICATION TEST:**
When the output signal (Positive half-wave) is less than 34Vp the voltage on D22 cathode must remain constant at 40V, when the output signal exceeds 34Vp the voltage must follow the output signal with 6V offset (see *Fig.2 Trace B*), to check the negative high rail connect the probe to D26 anode (see *Fig.2 Trace C*).
- ⊞ **LOAD CURRENT TEST:**
Connect the 4Ω 500W load on the output and repeat the LOW RAIL and HIGH RAIL tests.
- ⊞ **LIMITER CHECK:**
Increase the input signal of 10 dB and verify the output voltage and wave shape remain constant.
- ⊞ **BIAS ADJUSTMENT:**
With resistive load connected wait until the temperature reach 50°C. Set the level at zero, connect the Multimeter across the resistors R60, then adjust VR1 trimmer to read 6±0.1mVdc.
- ⊞ **BANDWIDTH CHECK:**
Disconnect the load. Set the generator at -10dB, sweeping the generator frequency from 10Hz to 10kHz the level changes accordingly *Fig.3 Trace 1a*.
- ⊞ **OFFSET SENSOR CHECK:**
Set the Variac to zero voltage output, disconnect resistive load from the amplifier output, connect temporarily (by means of a suitable conductor wire) CN1 pin 4 (+15Vdc) to R72 side RL1, the protection circuitry (Q14,15,16) detect the DC voltage and open the output relay (RL1) within 3 seconds approx.
Remove the connection, wait until the relay switch on and after some

seconds repeat the check with -15Vdc (available on CN1 pin 5), the protection circuitry must open the relay again.

◇ **SIGNAL TO NOISE RATIO CHECK:**

Disconnect the audio generator and short the input (pin 1,2,3 of XLR socket shorted) the output signal (noise) must be less than 1mV.

High Frequency Channel Check

◇ Verify, with the Multimeter, the insulation between the heatsink and the TDA7294 case.

◇ Set the audio generator to 5KHz 775mV_{RMS} (0dB) sinusoidal signal.

◇ Connect the CH2 probe tip to R260 side IC202 (HF PWR out) and set its sensitivity at 20V/div. 200µS/div.

◇ **VOLTAGE AMPLIFICATION TEST:**

Increase slowly the Variac. The channel output signals must be symmetrical respect the GND without visible distortion and oscillation. If there is a distortion replace the TDA7294.

◇ **LOAD CURRENT TEST:**

Connect the 8Ω 500W load on the output and repeat the test.

◇ **LIMITER CHECK:**

Increase the input signal of 10 dB and verify the output voltage and wave shape remain constant.

◇ **BANDWIDTH CHECK:**

Disconnect the load. Set the generator at -10dB, sweeping the generator frequency from 10Hz to 10kHz the level changes accordingly *Fig.3 Trace 1b*.

◇ **SIGNAL TO NOISE RATIO CHECK:**

Disconnect the audio generator and short the input (pin 1,2,3 of XLR socket shorted) the output signal (noise) must be less than 1mV.

PFM155A Amplified Subwoofer

The following adjustment and notes are relative to this model only.

Remarks

◇ The power supply utilizes a dual bipolar DC rail configuration with low and high voltages; one positive and one negative low rail (+/-Vcc1) and one positive and one negative high rail (+/-Vcc2).

Technical Specifications

Dimensions:	(WxHxD)	478x508x478mm
Weight:		24.5Kg
Power Requirements:	(230Vac±10% 50Hz)	350VA
	(115Vac±10% 50/60Hz)	350VA
Output Power*:	(4Ω)	350W
Max. Undistorted Out*:	(4Ω)	105Vpp
Sensitivity:	(1W/1m)	94dB _{SPL}
Max SPL:	(continuous)	118dB _{SPL}
	(peak)	121dB _{SPL}
Frequency Response	(filter+ampl.+speaker)	50Hz÷320Hz
	(only amplifier -3dB)	10Hz÷60KHz
Input Sensitivity:	(0dB)	0.775V _{RMS}
Input Impedance:	(balanced)	30KΩ

	(unbalanced)	15KΩ
Voltage Gain:	(@150Hz)	33±1dB
IMD:	(SMPTE 60Hz/7KHz 4:1)	<0.1%
THD:	(THD+N)	<0.1%
S/N Ratio:	(unweighted)	>100dB

Setup

◇ Connect the Variac between the mains and the amplifier and set it at zero voltage.

◇ Turn full clockwise the LEVEL and X-OVER potentiometers.

◇ Connect the audio generator to the channel R input and set it to 150Hz 775mV_{RMS} (0dB) sinusoidal signal.

◇ Place the temperature sensor between heatsink and the PTC (R59).

◇ Connect the CH1 scope GND clip to CN2 pin 6 (SGND terminal) and the probe tip to R72 side RL1 (PWR out), set its sensitivity at 20V/div. 10mS/div.

◇ Connect the CH2 probe tip to D25 cathode and set its sensitivity at 20V/div.

◇ The load resistor is disconnected.

◇ The procedures that follow must be executed subsequently in the order specified.

Supply Check

◇ Remove the transformer secondary fuses (located on SUPPLY board), set the Variac to the nominal mains voltage, check with the Multimeter the AC supply voltages:

F1-F2=102±2Vac

F3-F4=60±1.5Vac.

◇ Re-set the Variac at zero voltage, turn off the amplifier and put the fuses back on its holders.

◇ Set up the Variac slowly monitoring the Outputs with the oscilloscope CH1 connected, it should display the sinusoidal input signal amplified with no distortions, if a distortion occur check the AMPLIFIER board as suggested in the ADVICES section.

◇ If the protection trips, turn off the amplifier, wait some minutes and disconnect the supplies from the amplifier module (CN2, CN3 on AMPLIFIER board), continue to check the supplies.

◇ Finally verify the DC supplies on SUPPLY board:

CN2 pin 5 (+Vcc2) =+71±2Vdc

CN3 pin 1 (+Vcc1) =+42±1.5Vdc

CN3 pin 5-6 (-Vcc1) =-42±1.5Vdc

CN3 pin 4 (-Vcc2) =-71±2Vdc

CN2 pin 3 =+15±1Vdc

CN2 pin 2 =-15±1Vdc

◇ If one or more voltages don't correspond, check the rectifiers, capacitors and transformers disconnecting them from circuitry, refer to schematics.

Channels Check

◇ Verify, with the Multimeter, the insulation between the heatsink and the transistors collectors.

◇ Verify, with the Multimeter, the PTC resistor value (R59), it must be

between 50Ω and 200Ω.

◇ **INITIAL TEST:**

Increase slowly the Variac. The channel output signals must be symmetrical respect the GND without visible distortion and oscillation as shown in *Fig.1 Trace A* (*Trace B* shown the amplifier 2nd stage input R58 side C28). If there is a distortion read the section ADVICES.

◇ **HIGH RAIL CHECK:**

When the output signal (Positive half-wave) is less than 34Vp the voltage on D25 cathode must remain constant at 40V, when the output signal exceeds 40Vp the voltage must follow the output signal with 6V offset (see *Fig.2 Trace B*), to check the negative high rail connect the probe to D26 anode (see *Fig.2 Trace C*).

◇ **LOAD CURRENT TEST:**

Connect the 4Ω 500W load on the output and repeat the INITIAL and HIGH RAIL checks.

◇ **SIGN/COMP SENSOR CHECK:**

Set the LEVEL pot to minimum, set the scope timebase at 1V/div. 1mS/div., then increase the level and check the SIGNAL/COMP led activity: it must turn on (green light) when the amplifier output is higher than 1Vp.

Set the scope at 20V/div. and increase the level, check the led: it must change from green to red colour when the amplifier output signal is 50±2Vp, increasing the input level the output signal must keep the same level, this is due to the limiter-compression circuitry (IC2, DL1, IC1).

◇ **BIAS ADJUSTMENT:**

With the load connected wait until the temperature reach 50°C.

Set the generator level at zero, connect the Multimeter across the resistors R60, then adjust VR1 trimmer to read 15±0.1mVdc.

◇ **BANDWIDTH CHECK:**

The bandwidth of the amplifier board only is linear within the audio range (20Hz-20kHz), but in this case is limited by the X-OVER circuitry on CONTROLS & CROSSOVER board.

Figure 4 and 5 show the LowPass and the HighPass response, check the correspondance with it for some frequency values (50,100,150,300 for example).

◇ **OFFSET SENSOR CHECK:**

Set the Variac to zero voltage output, disconnect resistive load from the amplifier output, connect temporarily (by means of a suitable conductor wire) CN2 pin 3 (+15Vdc) to R72 side RL1, the protection circuitry (TR14,15,16) detect the DC voltage and open the output relay (RL1) within 3 seconds approx.

Remove the connection, wait until the relay switch on and after some seconds repeat the check with -15Vdc (available on CN2 pin 2), the protection circuitry must open the relay again.

◇ **SIGNAL TO NOISE RATIO CHECK:**

Disconnect the audio generator and short the input (pin 1,2,3 of XLR socket shorted) the output signal (noise) must be less than 1mV.

Advices

◇ If you have determinate that the problem is a short on a rail, you must check the output transistors to determine which transistor devices are bad.

Use a soldering iron to lift one leg of each emitter pin and measure the emitter-collector resistance on each device.

Unsolder and lift one leg of each base pin and check the base-collector resistance of each transistor and replace any that measure as a short. If all the transistors are OK, unsolder and lift one leg of each diode and check them.

Check the circuit board for open foil traces.

Use the Multimeter as Ohm-meter to check the resistors, particularly the base and emitter resistors of damaged transistor.

- ⊃ If the input sinewave appears to be distorted during the negative cycle, you can assume that the problem is located somewhere in the circuitry of the positive low rail.

If the positive cycle appears distorted, you can assume that the problem is in the circuitry of the negative low rail.

- ⊃ If the high rails appear distorted or are not modulating as shown in figure, then the problem probably exists somewhere in the circuitry of the respective (+ or -) defective high rail. Refer to the schematics.

Before reassembling the amplifier and before deliver it to the user, it is a goal verify its reliability with the following checks:

Reliability Check

- ⊃ Switch off the amplifier, or leaving it switched on but operating with greatest caution, carefully shake the boards and connections inside it using an insulated tool (for example the handle of a screwdriver) to find wrong contacts and so on.
- ⊃ Turn on the amplifier and verify that it operates correctly.

Burn in Check

- ⊃ Connect the appropriate load resistor to the output and a noise signal generator to the input, set it to pink noise with a 3:1 of crest factor and 0dB max level is preferable otherwise use a standard pink noise generator.
- ⊃ Leave the amplifier switched on for some hour and finally check its correct functionality after the test.

Figures

Figure 1 and 2 show the right shape of the traces but not their real levels, refer to the levels mentioned in the chapter of appropriate amplified loudspeaker.

Figure 3 shows the frequency response of the PFM15.3A crossover.

Figure 4 and 5 show the frequency response of the PFM15SA crossover.

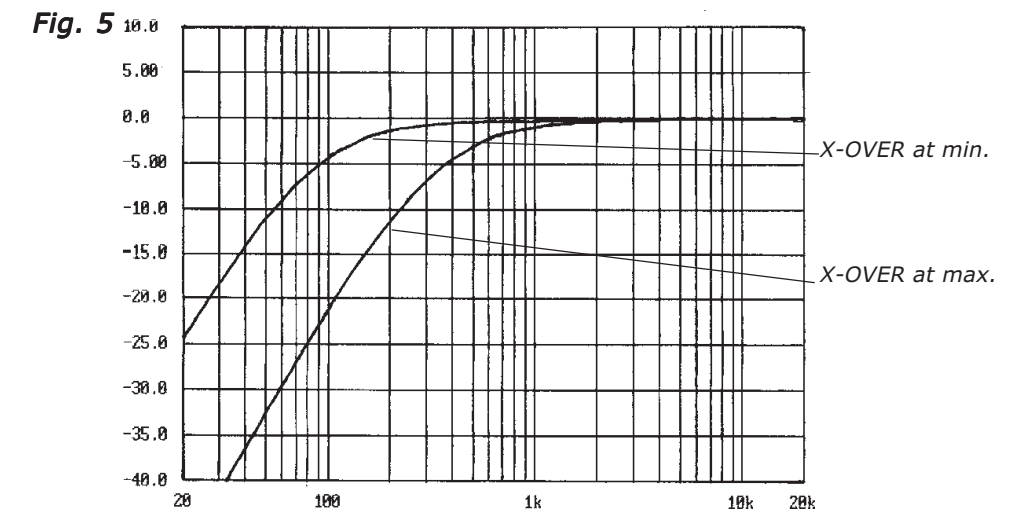
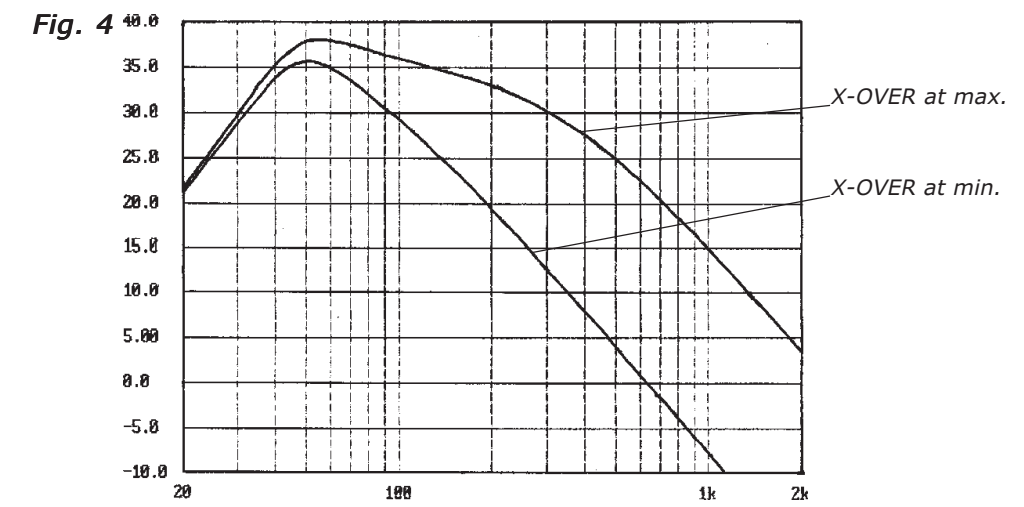
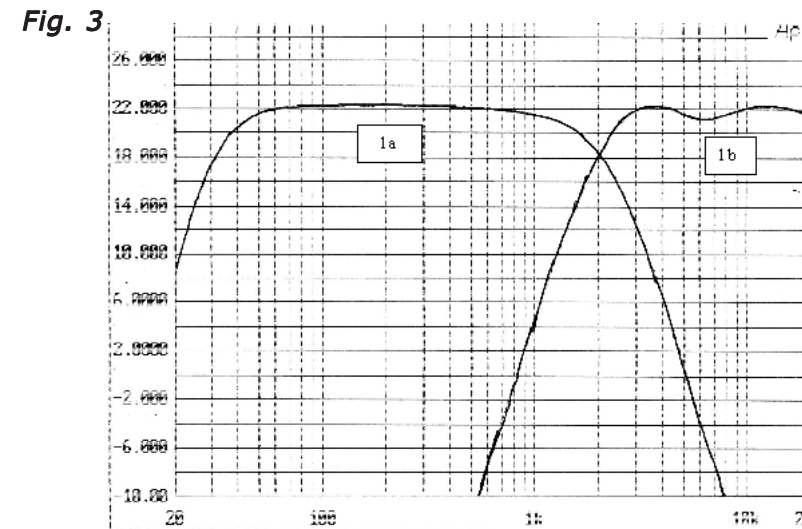
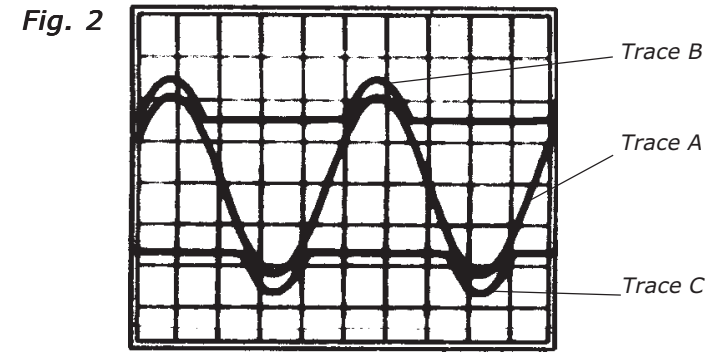
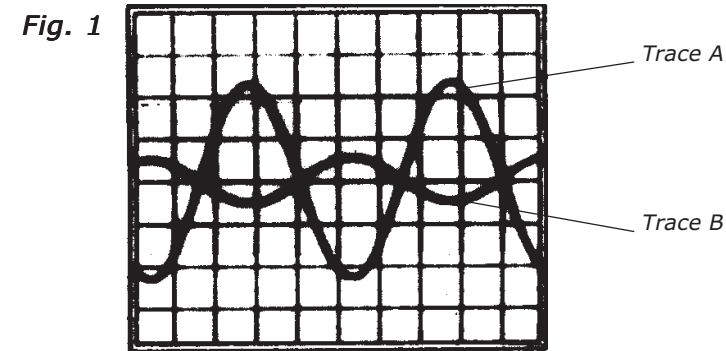

SMS768004
100W AMPLIFIER BOARD PFM10.2A/PFBMA
SMS768005
150W AMPLIFIER BOARD PFM12.2A/PF12.2MA

SMS768008
INPUT BOARD

SUBSONIC FILTER
24dB/oct.

OPTICAL
ANTI-CLIP
LIMITER

THERMIC
PROTECTION

BIAS ADJUSTMENT

SMS768000
100W SUPPLY BOARD PFM10.2A/PFBMA
SMS768001
150W SUPPLY BOARD PFM12.2A/PF12.2MA

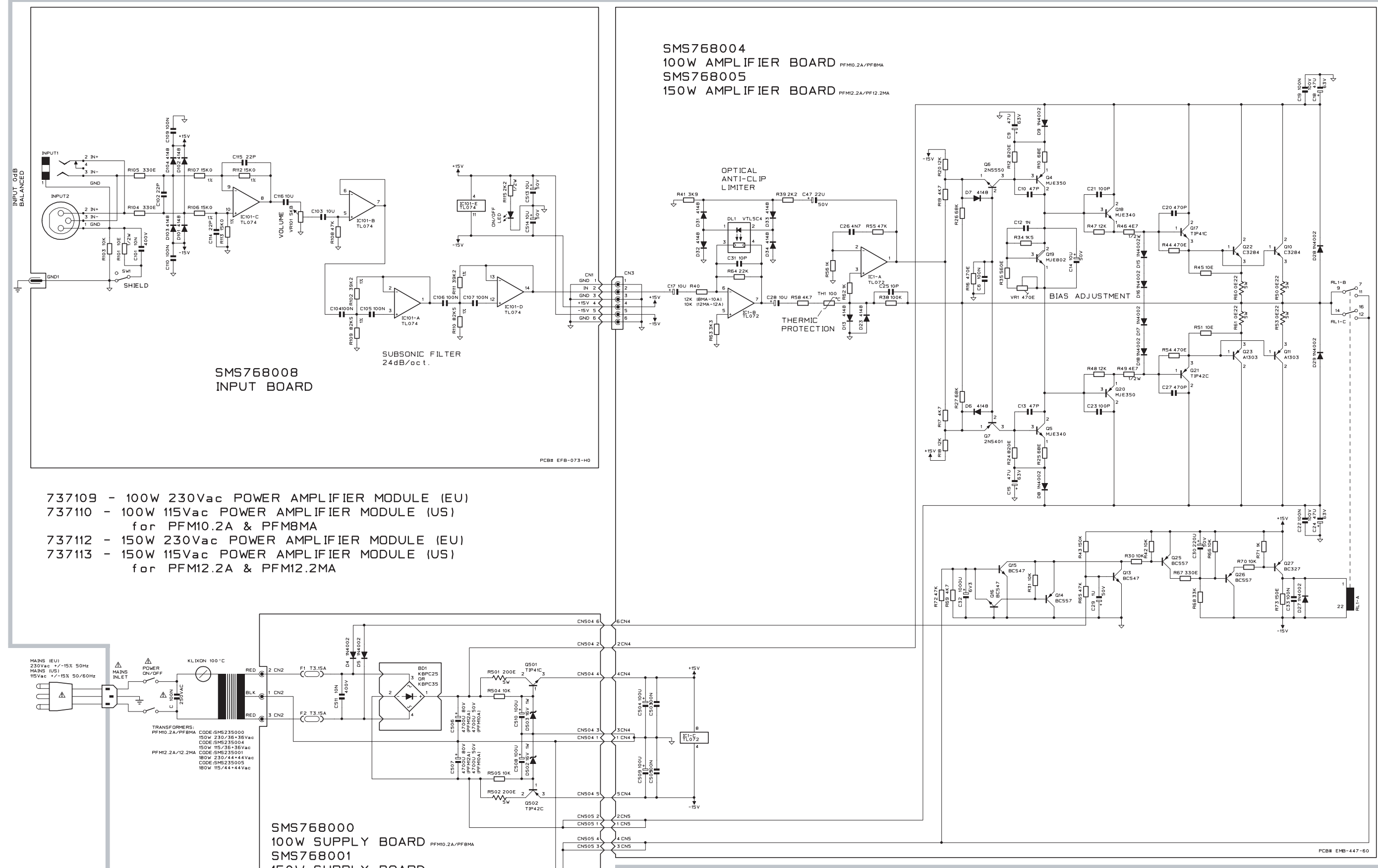

- 737109 - 100W 230Vac POWER AMPLIFIER MODULE (EU)
- 737110 - 100W 115Vac POWER AMPLIFIER MODULE (US)
for PFM10.2A & PFBMA
- 737112 - 150W 230Vac POWER AMPLIFIER MODULE (EU)
- 737113 - 150W 115Vac POWER AMPLIFIER MODULE (US)
for PFM12.2A & PFM12.2MA

TRANSFORMERS:
PFM10.2A/PFBMA CODE SMS235000
150W 230/35+35Vac
CODE SMS235004
150W 115/35+35Vac
PFM12.2A/12.2MA CODE SMS235001
180W 230/44+44Vac
CODE SMS235005
180W 115/44+44Vac

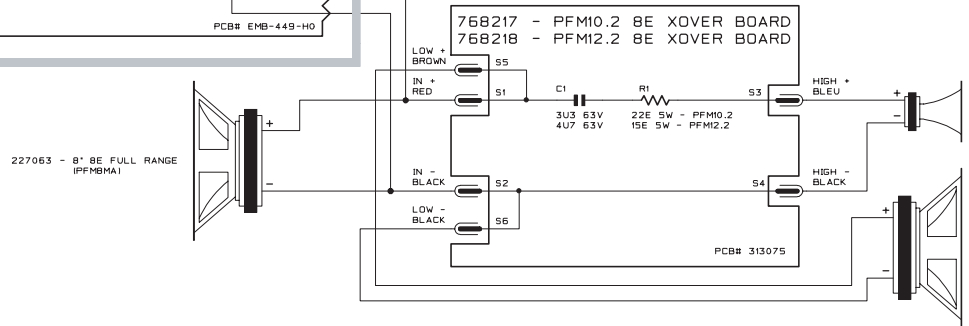

229043 - 12" TWEETER
IPFM10.2A/PFM12.2A/12.2MA

227064 - 10" BE WOOFER
227065 - 12" BE WOOFER
IPFM10.2A/12.2MA

DRW G.BOCATO	DWG# 550648	PCB# EFB-073 EMB-447 EMB-449 313075	GENERALMUSIC S.p.A. ITALY
CKD S.RICCI R.MAGALOTTI	DATE 12-10-2000	SCHEMATIC DIAGRAM PFM10.2A PFBMA PFM12.2MA	ALL RIGHTS ARE RESERVED. NO COPIES OR REPRODUCE THIS DOCUMENT WITHOUT WRITTEN CONSENT BY GENERALMUSIC.
APP. R.FALCONI	REV. A		

**SMS768010
INPUT & 80W AMPLIFIER BOARD**

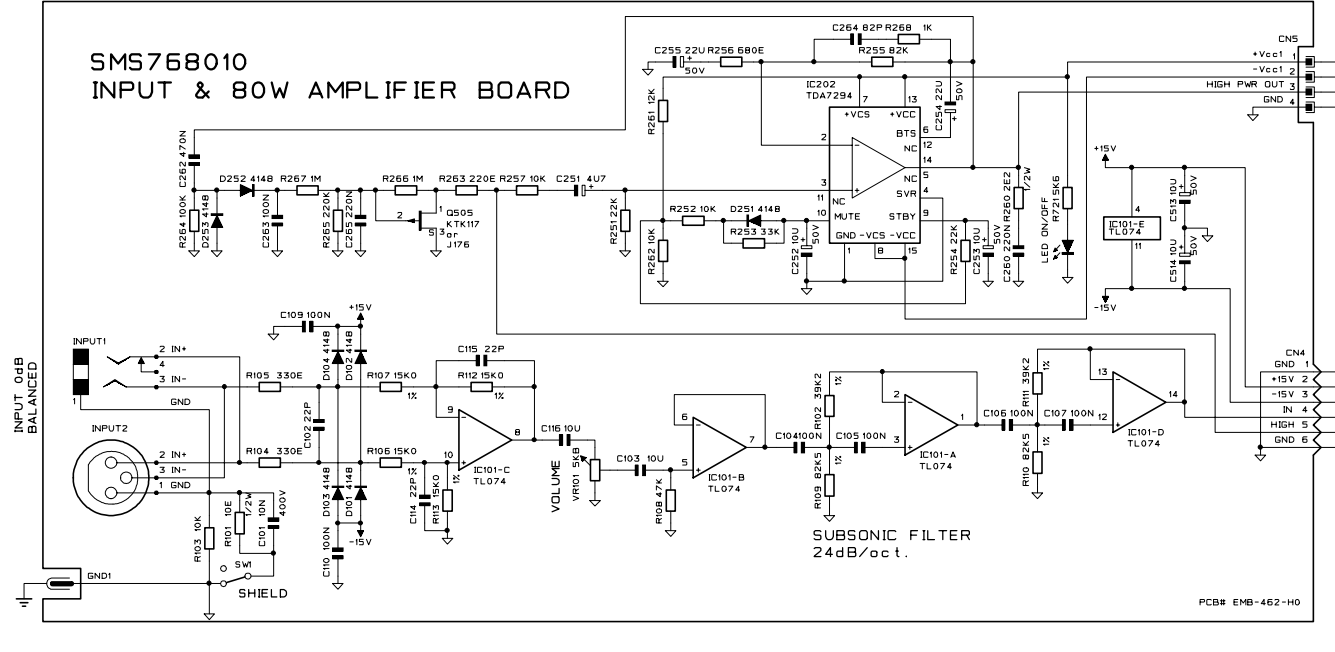

**SMS768010
INPUT & 80W AMPLIFIER BOARD**

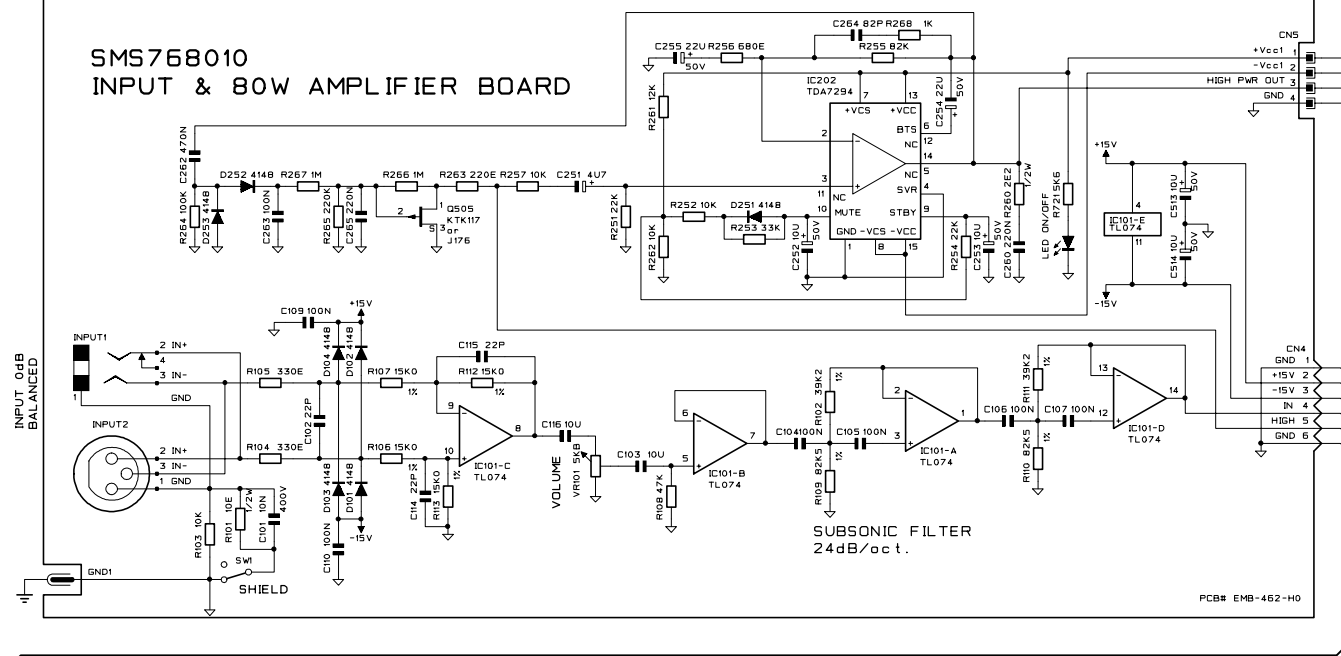

SMS768007 - XOVER & 230W AMPLIFIER BOARD

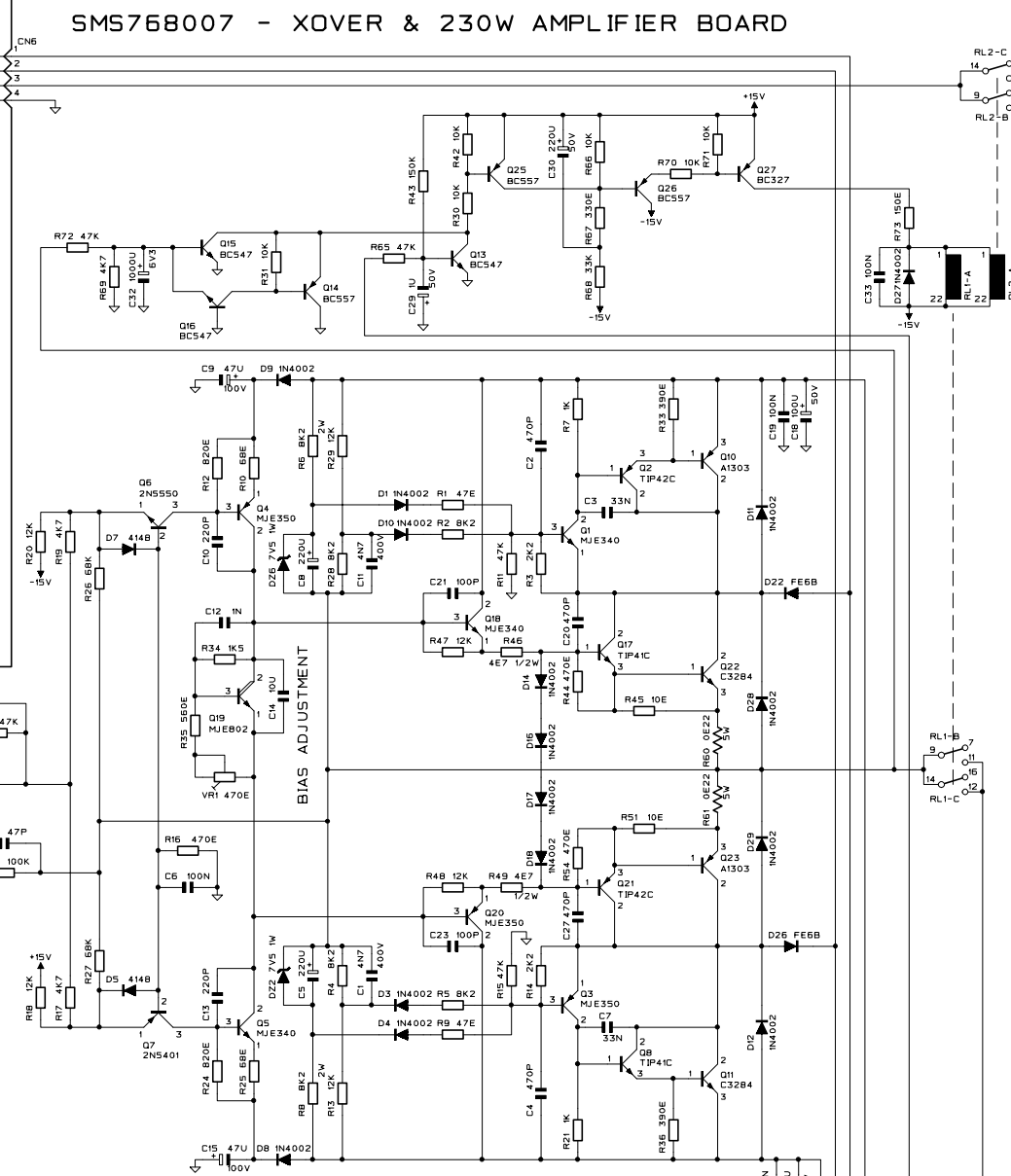

EQUALIZING FILTER

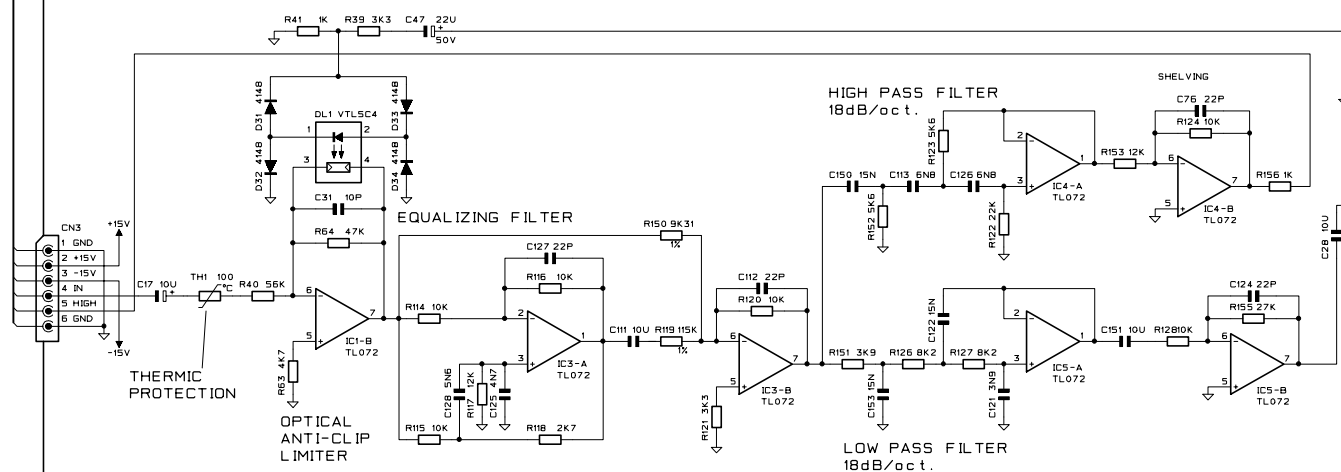

**HIGH PASS FILTER
18dB/oct.**

**LOW PASS FILTER
18dB/oct.**

737115 - 310W 230Vac POWER AMPLIFIER MODULE (EU)
737116 - 310W 115Vac POWER AMPLIFIER MODULE (US)
for PFM15.3A

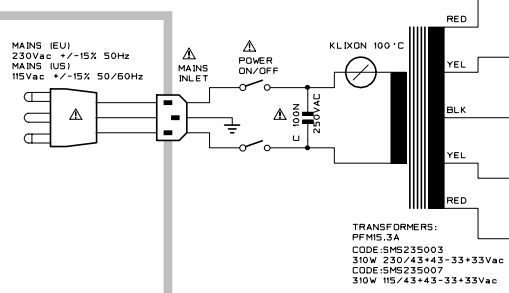

**SMS768003
230+80W SUPPLY BOARD**

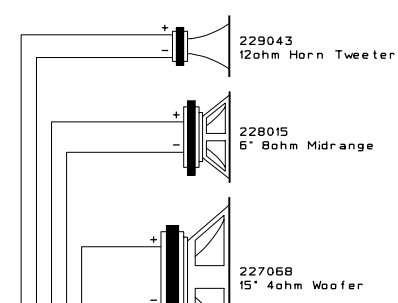
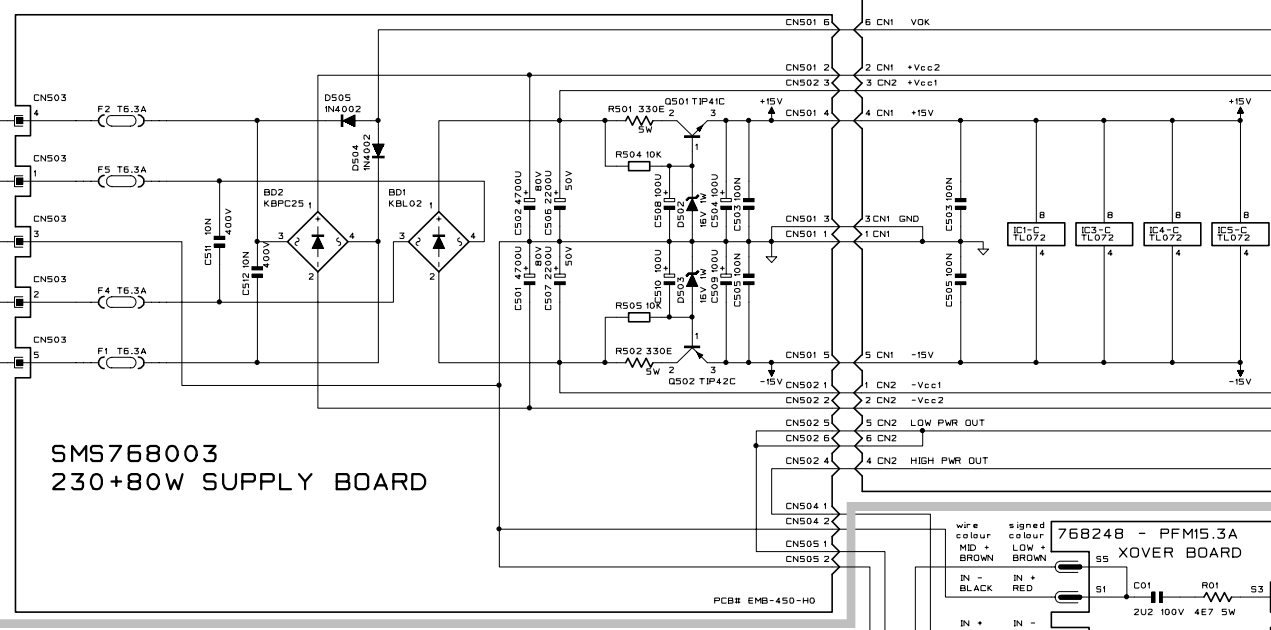

768181 - STEREO CROSSOVER & CONTROLS

768094 - 350W POWER AMPLIFIER BOARD

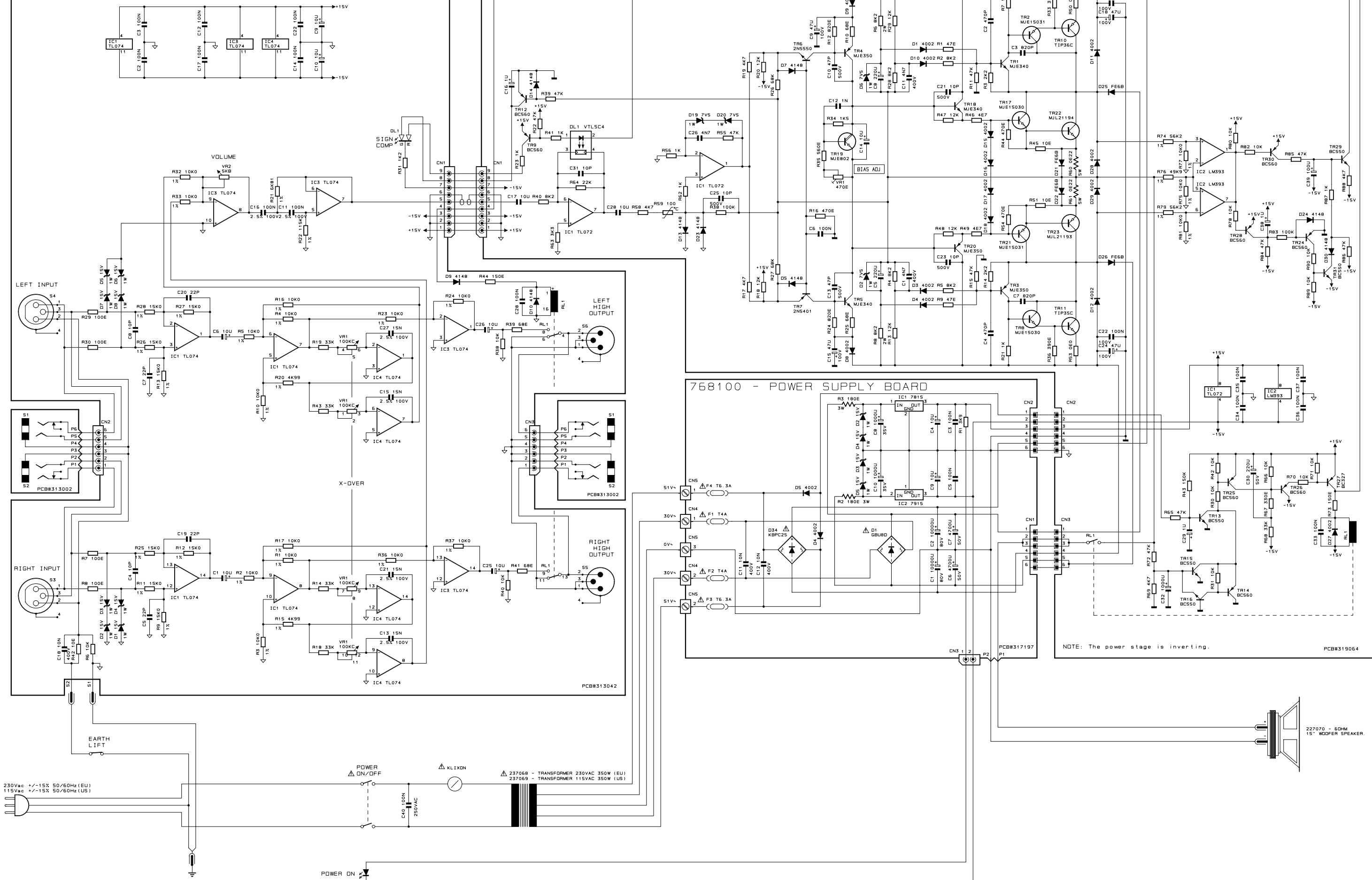

NOTE: The power stage is inverting.

230Vac +/-15% 50/60Hz (EU)
115Vac +/-15% 50/60Hz (US)

POWER ON/OFF
KL: XDN
237069 - TRANSFORMER 230VAC 350W (EU)
237069 - TRANSFORMER 115VAC 350W (US)

Spare Part List

Code	Description
	Optional Accessories
887069	15mt Jack-Jack Signal Cable
950860	SC20 Metal Telescopic stand
950199	SC30 Alluminium Telescopic stand
950978	SC31 Alluminium Telescopic stand

PASSIVE LOUDSPEAKERS

Accessories

277357	Owner's Manual (PFM 10X only)
277343	Owner's Manual

PFM-10X 8 Ohm

727613	Input Sockets Assembly
768232	* PFM-10X Crossover Board (Pcb#313083)
778154	** Cables Assembly
140226	** Jack Horizontal M-F Socket
060281	** 18E 5W 10% Wire Resistor
030171	** 4u7 63V 20% Axial Electrolytic Bipolar Capacitor
347401	* Input Sockets Panel
180693	* "Input" Adhesive Plate
717079	Speaker Box
667708	Speaker Net
347204	Jack Socket Cap
229044	12ohm Piezoelectric Tweeter
227064	10" 8ohm Woofer Speaker
210217	Black Sealer (specify mt)
180662	"Lem" Adhesive Blue Plate
120482	4mm Black Shakeproof Washer
120414	WL3.5x35tt Black Screw
120411	WL3.5x20tt Black Screw
370534	"Lem" Adhesive Logo

PFM-10.2 8 Ohm

778150	Speakers Cables Assembly
768217	PFM-10.2 Crossover Board (Pcb#313075)
210215	* Adhesive Rubber Foam 10x1.9mm (Specify mt)
120857	* Vertical Male Faston 6.3mm
060294	* 22E 5W 10% Wire Resistor
030160	* 3u3 100V 20% Axial Electrolytic Bipolar Capacitor
727610	Input Sockets Panel
778149	* Input Cables Assembly
140193	** Jack Mono Socket
667715	* Input Panel
120541	* 16x9x1.6 Washer for Jack
717067	Speaker Box Assembly
430072	* PFM-10.2 Covered Wooden Speaker Box
347396	* Belt Handle
340270	* 25x12mm Rubber Foot
177325	* Suspension Flange
120664	* M6 4-tips Lock Nut
120662	* M5 4-tips Lock Nut
120661	* M4 4-tips Lock Nut
120455	* 4,2x9x2 Washer
120346	* WL4x20tc Black Screw
120111	* M6x25tsp Black Screw
120102	* M4x30tsp Black Screw
667708	Speaker Net
347204	Jack Socket Cap
229043	12ohm Piezoelectric Horn Tweeter
227064	10" 8ohm Woofer Speaker
210273	Speaker Filler (400gr/m² 50x50x4cm)
210217	Black Sealer (specify mt)
180662	"Lem" Adhesive Blue Plate
120483	5mm Black Shakeproof Washer
120461	5.3X10X1 Black Washer
120414	WL3.5x35tt Black Screw
120411	WL3.5x20tt Black Screw
120364	WL3.5x12tt Black Screw
120124	M5x30tc Black Screw

PFM-12.2 8 Ohm

778150	Speakers Cables Assembly
768218	PFM-12.2 Crossover Board (Pcb#313075)
210215	* Adhesive Rubber Foam 10x1.9mm (Specify mt)
120857	* Vertical Male Faston 6.3mm
060275	* 15E 5W 10% Wire Resistor
030171	* 4u7 63V 20% Axial Electrolytic Bipolar Capacitor

727610	Input Sockets Panel
778149	* Input Cables Assembly
140193	** Jack Mono Socket
667715	* Input Panel
120541	* 16x9x1.6 Washer for Jack
717068	Speaker Box Assembly
430073	* PFM-12.2 Covered Wooden Speaker Box
347396	* Belt Handle
340270	* 25x12mm Rubber Foot
177325	* Suspension Flange
120664	* M6 4-tips Lock Nut
120662	* M5 4-tips Lock Nut
120661	* M4 4-tips Lock Nut
120455	* 4,2x9x2 Washer
120346	* WL4x20tc Black Screw
120111	* M6x25tsp Black Screw
120102	* M4x30tsp Black Screw
667709	Speaker Net
347204	Jack Socket Cap
229043	12ohm Piezoelectric Horn Tweeter
227065	12" 8ohm Woofer Speaker
210273	Speaker Filler (400gr/m² 50x50x4cm)
210217	Black Sealer (specify mt)
180662	"Lem" Adhesive Blue Plate
120483	5mm Black Shakeproof Washer
120461	5.3X10X1 Black Washer
120414	WL3.5x35tt Black Screw
120411	WL3.5x20tt Black Screw
120364	WL3.5x12tt Black Screw
120124	M5x30tc Black Screw

PFM-15.2 4 Ohm

778150	Speakers Cables Assembly
768219	PFM-15.2 4ohm Crossover Board (Pcb#313081)
210215	* Adhesive Rubber Foam 10x1.9mm (Specify mt)
120857	* Vertical Male Faston 6.3mm
061265	* 15E 20W 5% Wire Resistor
030095	* 2u2 100V 20% Axial Electrolytic Bipolar Capacitor
727609	Input Sockets Panel
778148	* Input Cables Assembly
140193	** Jack Mono Socket
667714	* Input Panel
717069	Speaker Box Assembly
430074	* PFM-15.2 Covered Wooden Speaker Box
347395	* Plastic Handle
340270	* 25x12mm Rubber Foot
177325	* Suspension Flange
120664	* M6 4-tips Lock Nut
120662	* M5 4-tips Lock Nut
120463	* 4.3x12.5x1 Black Washer
120411	* WL3.5x20tt Black Screw
120346	* WL4x20tc Black Screw
120111	* M6x25tsp Black Screw
667710	Speaker Net
229043	12ohm Piezoelectric Horn Tweeter
227066	15" 4ohm Woofer Speaker
210274	Speaker Filler (400gr/m² 100x50x4cm)
210217	Black Sealer (specify mt)
180662	"Lem" Adhesive Blue Plate
120483	5mm Black Shakeproof Washer
120461	5.3X10X1 Black Washer
120414	WL3.5x35tt Black Screw
120411	WL3.5x20tt Black Screw
120364	WL3.5x12tt Black Screw
120124	M5x30tc Black Screw

PFM-15.2 8 Ohm

778150	Speakers Cables Assembly
768220	PFM-15.2 8ohm Crossover Board (Pcb#313081)
210215	* Adhesive Rubber Foam 10x1.9mm (Specify mt)
120857	* Vertical Male Faston 6.3mm
061311	* 39E 20W 5% Wire Resistor
030171	* 4u7 63V 20% Axial Electrolytic Bipolar Capacitor
727610	Input Sockets Panel
778149	* Input Cables Assembly
140193	** Jack Mono Socket
667715	* Input Panel
120541	* 16x9x1.6 Washer for Jack
717069	Speaker Box Assembly
430074	* PFM-15.2 Covered Wooden Speaker Box
347395	* Plastic Handle
340270	* 25x12mm Rubber Foot
177325	* Suspension Flange

120664	* M6 4-tips Lock Nut
120662	* M5 4-tips Lock Nut
120463	* 4.3x12.5x1 Black Washer
120411	* WL3.5x20tt Black Screw
120346	* WL4x20tc Black Screw
120111	* M6x25tsp Black Screw
667710	Speaker Net
347204	Jack Socket Cap
229043	12ohm Piezoelectric Horn Tweeter
227067	15" 8ohm Woofer Speaker
210274	Speaker Filler (400gr/m² 100x50x4cm)
210217	Black Sealer (specify mt)
180662	"Lem" Adhesive Blue Plate
120483	5mm Black Shakeproof Washer
120461	5.3X10X1 Black Washer
120414	WL3.5x35tt Black Screw
120411	WL3.5x20tt Black Screw
120364	WL3.5x12tt Black Screw
120124	M5x30tc Black Screw

PFM-15.3 4 Ohm

778151	Speakers Cables Assembly
768221	PFM-15.3 4ohm Crossover Board (Pcb#313084)
230593	* 1.2mH 1mm Crossover Core Coil
230540	* 0.32mH 1mm Crossover Coil
210215	* Adhesive Rubber Foam 10x1.9mm (Specify mt)
177220	* Core Coil Support
120857	* Vertical Male Faston 6.3mm
120581	* M3 Black Self-Locking Nut
120003	* M3x8tc Black Screw
061207	* 4E7 20W 5% Wire Resistor
030248	* 10u 100V 20% Axial Electrolytic Bipolar Capacitor
020982	* 15u 100V 10% MKT Polyester Capacitor
020981	* 22u 100V 10% MKT Polyester Capacitor
020700	* 2u2 100V 10% MKT Polyester Capacitor

727609	Input Sockets Panel
778148	* Input Cables Assembly
140193	** Jack Mono Socket
667714	* Input Panel
717070	* Speakers Box Assembly
430075	* PFM-15.3 Covered Wooden Speaker Box
347395	* Plastic Handle
340270	* 25x12mm Rubber Foot
177325	* Suspension Flange
120664	* M6 4-tips Lock Nut
120662	* M5 4-tips Lock Nut
120463	* 4.3x12.5x1 Black Washer
120411	* WL3.5x20tt Black Screw
120346	* WL4x20tc Black Screw
120111	* M6x25tsp Black Screw
667711	Speaker Net
229043	12ohm Piezoelectric Horn Tweeter
228016	6" 4ohm Midrange Speaker
227068	15" 4ohm Woofer Speaker
210274	Speaker Filler (400gr/m² 100x50x4cm)
210217	Black Sealer (specify mt)
180662	"Lem" Adhesive Blue Plate
120483	5mm Black Shakeproof Washer
120482	4mm Black Shakeproof Washer
120461	5.3X10X1 Black Washer
120414	WL3.5x35tt Black Screw
120411	WL3.5x20tt Black Screw
120364	WL3.5x12tt Black Screw
120124	M5x30tc Black Screw

PFM-15.3 8 Ohm

778151	Speakers Cables Assembly
768222	PFM-15.3 8ohm Crossover Board (Pcb#313082)
230551	* 2.5mH 1mm Crossover Core Coil
230543	* 0.65mH 1mm Crossover Coil
210215	* Adhesive Rubber Foam 10x1.9mm (Specify mt)
177220	* Core Coil Support
120857	* Vertical Male Faston 6.3mm
120581	* M3 Black Self-Locking Nut
120003	* M3x8tc Black Screw
061231	* 8E2 20W 5% Wire Resistor
061221	* 6E8 20W 5% Wire Resistor
030171	* 4u7 63V 20% Axial Electrolytic Bipolar Capacitor
020982	* 15u 100V 10% MKT Polyester Capacitor
020979	* 10u 100V 10% MKT Polyester Capacitor
020695	* 1u5 100V 10% MKT Polyester Capacitor
727610	Input Sockets Panel
778149	* Input Cables Assembly

140193	** Jack Mono Socket
667715	* Input Panel
120541	* 16x9x1.6 Washer for Jack
717070	Speakers Box Assembly
430075	* PFM-15.3 Covered Wooden Speaker Box
347395	* Plastic Handle
340270	* 25x12mm Rubber Foot
177325	* Suspension Flange
120664	* M6 4-tips Lock Nut
120662	* M5 4-tips Lock Nut
120463	* 4.3x12.5x1 Black Washer
120411	* WL3.5x20tt Black Screw
120346	* WL4x20tc Black Screw
120111	* M6x25tsp Black Screw
667711	Speaker Net
347204	Jack Socket Cap
229043	12ohm Piezoelectric Horn Tweeter
228015	6" 8ohm Midrange Speaker
227069	15" 8ohm Woofer Speaker
210274	Speaker Filler (400gr/m² 100x50x4cm)
210217	Black Sealer (specify mt)
180662	"Lem" Adhesive Blue Plate
120483	5mm Black Shakeproof Washer
120482	4mm Black Shakeproof Washer
120461	5.3X10X1 Black Washer
120414	WL3.5x35tt Black Screw
120411	WL3.5x20tt Black Screw
120364	WL3.5x12tt Black Screw
120124	M5x30tc Black Screw

PFM-15S 4 Ohm

841208	Cables Assembly
768223	PFM-15S Crossover Board (Pcb#313064)
	the service support is made only by replacement the entire board

727611	Input Sockets Panel
778149	* Input Cables Assembly
140193	** Jack Mono Socket
778148	* Input Cables Assembly
140193	** Jack Mono Socket
667716	* Input Panel
120541	* 16x9x1.6 Washer for Jack
717071	Speakers Box Assembly
657265	* d=90 l=70mm Black Duct
430076	* PFM-15S Covered Wodden Speaker Box
347395	* Plastic Handle
340270	* 25x12mm Rubber Foot
177325	* Suspension Flange
120664	* M6 4-tips Lock Nut
120662	* M5 4-tips Lock Nut
120455	* 4,2x9x2 Washer
120411	* WL3.5x20tt Black Screw
120346	* WL4x20tc Black Screw
120111	* M6x25tsp Black Screw
667712	Speaker Net
347204	Jack Socket Cap
227070	15" 6ohm Woofer Speaker
210274	Speaker Filler (400gr/m² 100x50x4cm)
210217	Black Sealer (specify mt)
210215	Adhesive Rubber Foam 10x1.9mm (Specify mt)
180662	"Lem" Adhesive Blue Plate
120483	5mm Black Shakeproof Washer
120461	5.3X10X1 Black Washer
120414	WL3.5x35tt Black Screw
120411	WL3.5x20tt Black Screw
120364	WL3.5x12tt Black Screw
120124	M5x30tc Black Screw

ACTIVE LOUDSPEAKERS

Legend	
US =	Specify United States Version
EU =	Specify Europe Version

Accessories

277351	Owner's Manual
130297	Mains Cable (EU)
130283	Mains Cable (US)

PFM-10.2A

778150	Speakers Cables Assembly
768217	PFM-10.2 Crossover Board (Pcb#313075)
210215	* Adhesive Rubber Foam 10x1.9mm (Specify mt)

120857	* Vertical Male Faston 6.3mm
060294	* 22E 5W 10% Wire Resistor
030160	* 3u3 100V 20% Axial Electrolytic Bipolar Capacitor
737109	100W 230Vac Power Amplifier Module (EU)
737110	100W 115Vac Power Amplifier Module (US)
SMS768008	Input Board (Pcb# EFB-073-H0)
SMS141000	** XLR Female Socket
SMS110000	** Dual Slider Switch
140217	** Jack Slim Horizontal S-F Socket
100084	** TL074 Quad J-Fet Operational Amplifier
080743	** Led 3mm Wide Diffused Green
074570	** 5K 31steps Linear Potentiometer
042715	** 82K5 1/4W 1% Metalized Film Resistor
042672	** 39K2 1/4W 1% Metalized Film Resistor
042625	** 15K0 1/4W 1% Metalized Film Resistor
SMS768004	* 100W Amplifier Board (Pcb# EMB-447-60)
SMS090003	** 2SA1303 TO3P Pnp Transistor
SMS090002	** 2SC3284 TO3P Npn Transistor
SMS090001	** TIP42C TO220 Pnp Transistor
SMS090000	** TIP41C TO220 Npn Transistor
110307	** Relay 24V / 2 Switch 5A 250Vac
100061	** TL072 Dual J-Fet Operational Amplifier
090920	** MJE802 TO126 Npn Darl Transistor
090917	** MJE350 TO126 Pnp Transistor
090916	** MJE340 TO126 Npn Transistor
090201	** 2N5401 TO92 Pnp Transistor
090200	** 2N5550 TO92 Npn Transistor
090194	** BC560C TO92 LN Pnp Transistor (BC557C Equivalent)

090183	** BC550C TO92 LN Npn Transistor (BC547C Equivalent)
090153	** BC

060275	*	15E 5W 10% Wire Resistor
030171	*	4u7 63V 20% Axial Electrolytic Bipolar Capacitor
737111	150W 230Vac Power Amplifier Module (EU)	
737112	150W 115Vac Power Amplifier Module (US)	
SMS768008	* Input Board (Pcb# EFB-073-H0)	
SMS141000	**	XLR Female Socket
SMS110000	**	Dual Slider Switch
140217	**	Jack Slim Horizontal S-F Socket
100084	**	TL074 Quad J-Fet Operational Amplifier
080743	**	Led 3mm Wide Diffused Green
074570	**	5K 31steps Linear Potentiometer
042715	**	82K5 1/4W 1% Metalized Film Resistor
042672	**	39K2 1/4W 1% Metalized Film Resistor
042625	**	15K0 1/4W 1% Metalized Film Resistor
SMS768005	* 150W Amplifier Board (Pcb# EMB-447-60)	
SMS090003	**	2SA1303 TO3P Pnp Transistor
SMS090002	**	2SC3284 TO3P Npn Transistor
SMS090001	**	TIP42C TO220 Pnp Transistor
SMS090000	**	TIP41C TO220 Npn Transistor
110307	**	Relay 24V / 2 Switch 5A 250Vac
100061	**	TL072 Dual J-Fet Operational Amplifier
090920	**	MJE802 TO126 Npn Darl Transistor
090917	**	MJE350 TO126 Pnp Transistor
090916	**	MJE340 TO126 Npn Transistor
090201	**	2N5401 TO92 Pnp Transistor
090200	**	2N5550 TO92 Npn Transistor
090194	**	BC560C TO92 LN Pnp Transistor (BC557C Equivalent)
090183	**	BC550C TO92 LN Npn Transistor (BC547C Equivalent)
090153	**	BC327 TO92 Pnp Transistor
080901	**	VTL5C4 Analog Optoisolator
080821	**	Ptc 90 PTH59F04BE222TS
080156	**	1N4002 1A 100V Rectifier Diode
080103	**	1N4148 100mA 75V Signal Diode
060051	**	0E22 5W 5% Wire Resistor
030715	**	1000u 6v3 20% Vert Electrolytic Capacitor
SMS768001	* 150W Supply Board (Pcb# EMB-449-H0)	
SMS090001	**	TIP42C TO220 Pnp Transistor
SMS090000	**	TIP41C TO220 Npn Transistor
110119	**	Fuse Clip 10A max (EU) (US)
080292	**	16V 1W 5% Zener Diode
080156	**	1N4002 1A 100V Rectifier Diode
060413	**	220E 5W 10% Resistor
030560	**	4700u 80v 20% Snap-In Electrolytic Capacitor
667738	*	Amplifier Panel/Chassis
SMS235001	* 180W 230Vac Transformer (EU)	
SMS235005	* 180W 115Vac Transformer (US)	
110061	*	T3.15A Fuse 6.3x32mm (US)
110003	*	T3.15A Fuse 5x20mm (EU)
110614	*	Mains Socket
110285	*	4A 250Vac Bipolar Power Switch
080607	*	KBPC25 25A 200V Rectifier Diode Bridge
020491	*	100nF 10% 250Vac Polyester Capacitor
717073	Speaker Box Assembly	
430078	*	PFM-12.2A Covered Wooden Speaker Box
347396	*	Belt Handle
340270	*	25x12mm Rubber Foot
177325	*	Suspension Flange
120664	*	M6 4-tips Lock Nut
120662	*	M5 4-tips Lock Nut
120661	*	M4 4-tips Lock Nut
120455	*	4,2x9x2 Washer
120411	*	WL3.5x20tt Black Screw
120111	*	M6x25tsp Black Screw
120102	*	M4x30tsp Black Screw
667709		Speaker Net
659027		White Pot Knob
229043	12ohm Piezoelectric Horn Tweeter	
227065	12" 8ohm Woofer Speaker	
210273		Speaker Filler (400gr/m² 50x50x4cm)
210217		Black Sealer (specify mt)
180662		"Lem" Adhesive Blue Plate
120483		5mm Black Shakeproof Washer
120461		5.3X10X1 Black Washer
120414		WL3.5x35tt Black Screw
120411		WL3.5x20tt Black Screw
120364		WL3.5x12tt Black Screw
120124		M5x30tc Black Screw

PFM-15.2A

778150		Speakers Cables Assembly
768219	PFM-15.2 4ohm Crossover Board (Pcb#313081)	
210215	*	Adhesive Rubber Foam 10x1.9mm (Specify mt)

120857	*	Vertical Male Faston 6.3mm
061265	*	15E 20W 5% Wire Resistor
030095	*	2u2 100V 20% Axial Electrolytic Bipolar Capacitor
737113	250W 230Vac Power Amplifier Module (EU)	
737114	250W 115Vac Power Amplifier Module (US)	
SMS768009	* Input Board (Pcb# EFB-074-H0)	
SMS141000	**	XLR Female Socket
SMS110000	**	Dual Slider Switch
141102	**	6 Contacts Vert Male Connector
140217	**	Jack Slim Horizontal S-F Socket
100084	**	TL074 Quad J-Fet Operational Amplifier
080743	**	Led 3mm Wide Diffused Green
074570	**	5K 31steps Linear Potentiometer
042715	**	82K5 1/4W 1% Metalized Film Resistor
042672	**	39K2 1/4W 1% Metalized Film Resistor
042625	**	15K0 1/4W 1% Metalized Film Resistor
SMS768006	* 250W Amplifier Board (Pcb# EMB-456-60)	
SMS090003	**	2SA1303 TO3P Pnp Transistor
SMS090002	**	2SC3284 TO3P Npn Transistor
SMS090001	**	TIP42C TO220 Pnp Transistor
SMS090000	**	TIP41C TO220 Npn Transistor
110316	**	Relay 24V / 1 Switch no 16A 250V
100061	**	TL072 Dual J-Fet Operational Amplifier
090920	**	MJE802 TO126 Npn Darl Transistor
090917	**	MJE350 TO126 Pnp Transistor
090916	**	MJE340 TO126 Npn Transistor
090201	**	2N5401 TO92 Pnp Transistor
090200	**	2N5550 TO92 Npn Transistor
090194	**	BC560C TO92 LN Pnp Transistor (BC557C Equivalent)
090183	**	BC550C TO92 LN Npn Transistor
090153	**	BC327 TO92 Pnp Transistor
080901	**	VTL5C4 Analog Optoisolator
080821	**	Ptc 90 PTH59F04BE222TS
080156	**	1N4002 1A 100V Rectifier Diode
080103	**	1N4148 100mA 75V Signal Diode
060051	**	0E22 5W 5% Wire Resistor
030715	**	1000u 6v3 20% Vert Electrolytic Capacitor
SMS768002	* 250W Supply Board (Pcb# EMB-450-H0)	
SMS090001	**	TIP42C TO220 Pnp Transistor
SMS090000	**	TIP41C TO220 Npn Transistor
SMS030000	**	2200uF 50VL 18x36mm TWSS Rubycon
110119	**	Fuse Clip 10A max (EU) (US)
080606	**	GBU8D 8A Rectifier Diodes Bridge
080292	**	16V 1W 5% Zener Diode
080156	**	1N4002 1A 100V Rectifier Diode
060413	**	220E 5W 10% Resistor
030560	**	4700u 80v 20% Snap-In Electrolytic Capacitor
667739	*	Amplifier Panel/Chassis
SMS235002	* 250W 230Vac Transformer (EU)	
SMS235006	* 250W 115Vac Transformer (US)	
110614	*	Mains Socket
110291	*	16A 250Vac Bipolar Power Switch
110020	*	T5A Fuse 5x20mm (EU)
110021	*	T5A Fuse 6.3x32mm (US)
080608	*	KBPC3502 35A 200V Rectifier Diode Bridge
020491	*	100nF 10% 250Vac Polyester Capacitor
717074	Speaker Box Assembly	
430079	*	PFM-15.2A Covered Wooden Speaker Box
347395	*	Plastic Handle
340270	*	25x12mm Rubber Foot
177325	*	Suspension Flange
120664	*	M6 4-tips Lock Nut
120662	*	M5 4-tips Lock Nut
120661	*	M4 4-tips Lock Nut
120463	*	4.3x12.5x1 Black Washer
120411	*	WL3.5x20tt Black Screw
120346	*	WL4x20tc Black Screw
120111	*	M6x25tsp Black Screw
667710		Speaker Net
659027		White Pot Knob
229043	12ohm Piezoelectric Horn Tweeter	
227066	15" 4ohm Woofer Speaker	
210274		Speaker Filler (400gr/m² 100x50x4cm)
210217		Black Sealer (specify mt)
180662		"Lem" Adhesive Blue Plate
120483		5mm Black Shakeproof Washer
120461		5.3X10X1 Black Washer
120414		WL3.5x35tt Black Screw
120411		WL3.5x20tt Black Screw
120364		WL3.5x12tt Black Screw
120124		M5x30tc Black Screw
120059		M4x25tc Black Screw

PFM-15.3A

778150		Speakers Cables Assembly
768248	PFM-15.3A Crossover Board (Pcb#313075)	
210215	*	Adhesive Rubber Foam 10x1.9mm (Specify mt)
120857	*	Vertical Male Faston 6.3mm
060214	*	4E7 5W 10% Wire Resistor
030095	*	2u2 100V 20% Axial Electrolytic Bipolar Capacitor
737115	230+80W 230Vac Power Amplifier Module (EU)	
737116	230+80W 115Vac Power Amplifier Module (US)	
SMS768010	* Input & 80W Amplifier Board (Pcb# EMB-462-H0)	
SMS141000	**	XLR Female Socket
SMS110000	**	Dual Slider Switch
141102	**	6 Contacts Vert Male Connector
140217	**	Jack Slim Horizontal S-F Socket
100965	**	TDA7294 80W Audio Amplifier with Mute
100084	**	TL074 Quad J-Fet Operational Amplifier
080743	**	Led 3mm Wide Diffused Green
074570	**	5K 31steps Linear Potentiometer
042715	**	82K5 1/4W 1% Metalized Film Resistor
042672	**	39K2 1/4W 1% Metalized Film Resistor
042625	**	15K0 1/4W 1% Metalized Film Resistor
SMS768007	* Xover & 230W Amplifier Board (Pcb# EMB-456-60)	
SMS090003	**	2SA1303 TO3P Pnp Transistor
SMS090002	**	2SC3284 TO3P Npn Transistor
SMS090001	**	TIP42C TO220 Pnp Transistor
SMS090000	**	TIP41C TO220 Npn Transistor
110316	**	Relay 24V / 1 Switch no 16A 250V
100061	**	TL072 Dual J-Fet Operational Amplifier
090920	**	MJE802 TO126 Npn Darl Transistor
090917	**	MJE350 TO126 Pnp Transistor
090916	**	MJE340 TO126 Npn Transistor
090201	**	2N5401 TO92 Pnp Transistor
090200	**	2N5550 TO92 Npn Transistor
090194	**	BC560C TO92 LN Pnp Transistor (BC557C Equivalent)
090183	**	BC550C TO92 LN Npn Transistor
090153	**	BC327 TO92 Pnp Transistor
080901	**	VTL5C4 Analog Optoisolator
080821	**	Ptc 90 PTH59F04BE222TS
080156	**	1N4002 1A 100V Rectifier Diode
080103	**	1N4148 100mA 75V Signal Diode
060051	**	0E22 5W 5% Wire Resistor
030715	**	1000u 6v3 20% Vert Electrolytic Capacitor
090153	**	BC327 TO92 Pnp Transistor
080901	**	VTL5C4 Analog Optoisolator
080821	**	Ptc 90 PTH59F04BE222TS
080156	**	1N4002 1A 100V Rectifier Diode
080103	**	1N4148 100mA 75V Signal Diode
060051	**	0E22 5W 5% Wire Resistor
030715	**	1000u 6v3 20% Vert Electrolytic Capacitor
SMS768003	* 230+80W Supply Board (Pcb# EMB-450-H0)	
SMS090001	**	TIP42C TO220 Pnp Transistor
SMS090000	**	TIP41C TO220 Npn Transistor
SMS030000	**	2200uF 50VL 18x36mm TWSS Rubycon
110119	**	Fuse Clip 10A max (EU) (US)
080606	**	GBU8D 8A Rectifier Diodes Bridge
080292	**	16V 1W 5% Zener Diode
080156	**	1N4002 1A 100V Rectifier Diode
060413	**	220E 5W 10% Resistor
030560	**	4700u 80v 20% Snap-In Electrolytic Capacitor
667739	*	Amplifier Panel/Chassis
SMS235003	* 310W 230Vac Transformer (EU)	
SMS235007	* 310W 115Vac Transformer (US)	
110614	*	Mains Socket
110291	*	16A 250Vac Bipolar Power Switch
110018	*	T6.3A Fuse 5x20mm (EU)
110037	*	T6.3A Fuse 6.3x32mm (US)
080608	*	KBPC3502 35A 200V Rectifier Diode Bridge
020491	*	100nF 10% 250Vac Polyester Capacitor
717075	Speaker Box Assembly	
430080	*	PFM-15.3A Covered Wooden Speaker Box
347395	*	Plastic Handle
340270	*	25x12mm Rubber Foot
177325	*	Suspension Flange
120664	*	M6 4-tips Lock Nut
120662	*	M5 4-tips Lock Nut
120661	*	M4 4-tips Lock Nut
120463	*	4.3x12.5x1 Black Washer
120411	*	WL3.5x20tt Black Screw
120346	*	WL4x20tc Black Screw
120111	*	M6x25tsp Black Screw
667711		Speaker Net
659027		White Pot Knob
229043	12ohm Piezoelectric Horn Tweeter	
228015	6" 8ohm Midrange Speaker	
227068	15" 4ohm Woofer Speaker	
210274		Speaker Filler (400gr/m² 100x50x4cm)
210217		Black Sealer (specify mt)
180662		"Lem" Adhesive Blue Plate
120483		5mm Black Shakeproof Washer

120482		4mm Black Shakeproof Washer
120461		5.3X10X1 Black Washer
120453		4.2x9x0.8 Black Washer
120414		WL3.5x35tt Black Screw
120411		WL3.5x20tt Black Screw
120364		WL3.5x12tt Black Screw
120346		WL4x20tc Black Screw
120124		M5x30tc Black Screw
120059		M4x25tc Black Screw

PFM-15SA

737090	350W 230Vac Power Amplifier Module (EU)	
737091	350W 115Vac Power Amplifier Module (US)	
778134	*	Cables Assemblies
080716	**	Led 5mm 60deg Diffused Green
768181	* Inputs & Crossover Board (PCB#313042)	
141187	**	Hor Female XLR Socket (NC3FAH Neutrik)
141186	**	Hor Male XLR Socket (NC3MAH Neutrik)
140929	**	9 Contacts Vert Male Connector
140908	**	6 Contacts Vert Male Small Connector
120857	**	Vertical Male Faston 6.3mm
110305	**	Relay 12V / 2 Switch 1A 250V
100084	**	TL074 Quad J-Fet Operational Amplifier
080734	**	Led 2.5x5mm Rect Diff Red-Grn
080293	**	15V 1W 5% Zener Diode
080103	**	1N4148 100mA 75V Signal Diode
075820	**	4x100K Alog Potentiometer Alps RK1631410
074570	**	5K 31steps Linear Potentiometer
042730	**	115K 1/4W 1% Metalized Film Resistor
042625	**	15K0 1/4W 1% Metalized Film Resistor
042605	**	10K0 1/4w 1% Metalized Film Resistor
042585	**	6K81 1/4w 1% Metalized Film Resistor
042565	**	4K99 1/4w 1% Metalized Film Resistor
022024	**	100n 2.5% 100V MKP Polypropylene Capacitor
022014	**	15n 2.5% 100V MKP Polypropylene Capacitor
768109	* Jack Sockets Board (PCB#313002)	
778111	**	6 Contacts Female Cable
140217	**	Jack Stereo Slim Horizontal Socket
727562	* Power Amplifier Assembly	
768100	** Power Supply Board (PCB#317197)	
140917	***	2 Contacts Vert Male Connector
140081	***	H 2c P=10 Terminal Block
140069	***	H 3c P=10mm Terminal Block
110119	***	Fuse Clip 10A max (EU) (US)
100060	***	7815 +15V 1A Voltage Regulator
100049	***	7915 -15V 1A Voltage Regulator
080606	***	GBU8D 8A Rectifier Diodes Bridge
080342	***	30V 1W 5% Zener Diode
080293	***	15V 1W 5% Zener Diode
080156	***	1N4002 1A 100V Rectifier Diode
060403	***	180E 3W 10% Resistor
030884	***	10000U 80V 20% Snap-In Electrolytic Capacitor
030555	***	4700u 50V 20% Snap-In Electrolytic Capacitor
768094	** Power Amplifier Board (PCB#319064)	
140929	***	9 Contacts Vert Male Connector
140927	***	24 Contacts Vert Male Strip
110316	***	Relay 24V / 1 Switch no 16A 250V
100904	***	LM393 Dual Comparator
100061	***	TL072 Dual J-Fet Operational Amplifier
090917	***	MJE350 TO126 Pnp Transistor
090916	***	MJE340 TO126 Npn Transistor
09020		

090201	**	2N5401 TO92 Pnp Transistor
090200	**	2N5550 TO92 Npn Transistor
090194	**	BC560C TO92 LN Pnp Transistor (BC557C Equivalent)
090183	**	BC550C TO92 LN Npn Transistor (BC547C Equivalent)
090153	**	BC327 TO92 Pnp Transistor
080901	**	VTL5C4 Analog Optoisolator
080821	**	Ptc 90 PTH59F04BE222TS
080156	**	1N4002 1A 100V Rectifier Diode
080103	**	1N4148 100mA 75V Signal Diode
060051	**	0E22 5W 5% Wire Resistor
030715	**	1000u 6v3 20% Vert Electrolytic Capacitor
SMS768000	*	100W Supply Board (Pcb# EMB-449-H0)
110119	**	Fuse Clip 10A max (EU) (US)
080292	**	16V 1W 5% Zener Diode
080156	**	1N4002 1A 100V Rectifier Diode
060413	**	220E 5W 10% Resistor
030555	**	4700u 50V 20% Snap-In Electrolytic Capacitor
667738	*	Amplifier Panel/Chassis
SMS235000	*	150W 230Vac Transformer (EU)
SMS235004	*	150W 115Vac Transformer (US)
110614	*	Mains Socket
110285	*	4A 250Vac Bipolar Power Switch
110003	*	T3.15A Fuse 5x20mm (EU)
110061	*	T3.15A Fuse 6.3x32mm (US)
080607	*	KBPC25 25A 200V Rectifier Diode Bridge
020491	*	100nF 10% 250Vac Polyester Capacitor
717077		Speaker Box Assembly
430082	*	PFM-8MA Covered Wodden Speaker Box
347396	*	Belt Handle
340270	*	25x12mm Rubber Foot
177325	*	Suspension Flange
120664	*	M6 4-tips Lock Nut
120661	*	M4 4-tips Lock Nut
120455	*	4,2x9x2 Washer
120411	*	WL3.5x20tt Black Screw
120111	*	M6x25tsp Black Screw
120102	*	M4x30tsp Black Screw
667713		Speaker Net
659027		White Pot Knob
227063		8" 8ohm Speaker
210272		Speaker Filler (400gr/m² 30x50x4cm)
210217		Black Sealer (specify mt)
180662		"Lem" Adhesive Blue Plate
120482		4mm Black Shakeproof Washer
120414		WL3.5x35tt Black Screw
120411		WL3.5x20tt Black Screw

PFM-12.2MA

778150		Speakers Cables Assembly
768218		PFM-12.2 Crossover Board (Pcb#313075)
210215	*	Adhesive Rubber Foam 10x1.9mm (Specify mt)
120857	*	Vertical Male Faston 6.3mm
060275	*	15E 5W 10% Wire Resistor
030171	*	4u7 63V 20% Axial Electrolytic Bipolar Capacitor
737111		150W 230Vac Power Amplifier Module (EU)
737112		150W 115Vac Power Amplifier Module (US)
SMS768008	*	Input Board (Pcb# EFB-073-H0)
SMS141000	**	XLR Female Socket
SMS110000	**	Dual Slider Switch
140217	**	Jack Slim Horizontal S-F Socket
100084	**	TL074 Quad J-Fet Operational Amplifier
080743	**	Led 3mm Wide Diffused Green
074570	**	5K 31steps Linear Potentiometer
042715	**	82K5 1/4W 1% Metalized Film Resistor
042672	**	39K2 1/4W 1% Metalized Film Resistor
042625	**	15K0 1/4W 1% Metalized Film Resistor
SMS768005	*	150W Amplifier Board (Pcb# EMB-447-60)
SMS090003	**	2SA1303 TO3P Pnp Transistor
SMS090002	**	2SC3284 TO3P Npn Transistor
SMS090001	**	TIP42C TO220 Pnp Transistor
SMS090000	**	TIP41C TO220 Npn Transistor
110307	**	Relay 24V / 2 Switch 5A 250Vac
100061	**	TL072 Dual J-Fet Operational Amplifier
090920	**	MJE802 TO126 Npn Darl Transistor
090917	**	MJE350 TO126 Pnp Transistor
090916	**	MJE340 TO126 Npn Transistor
090201	**	2N5401 TO92 Pnp Transistor
090200	**	2N5550 TO92 Npn Transistor
090194	**	BC560C TO92 LN Pnp Transistor (BC557C Equivalent)
090183	**	BC550C TO92 LN Npn Transistor (BC547C Equivalent)

090153	**	BC327 TO92 Pnp Transistor
080901	**	VTL5C4 Analog Optoisolator
080821	**	Ptc 90 PTH59F04BE222TS
080156	**	1N4002 1A 100V Rectifier Diode
080103	**	1N4148 100mA 75V Signal Diode
060051	**	0E22 5W 5% Wire Resistor
030715	**	1000u 6v3 20% Vert Electrolytic Capacitor
SMS768001	*	150W Supply Board (Pcb# EMB-449-H0)
SMS090001	**	TIP42C TO220 Pnp Transistor
SMS090000	**	TIP41C TO220 Npn Transistor
110119	**	Fuse Clip 10A max (EU) (US)
080292	**	16V 1W 5% Zener Diode
080156	**	1N4002 1A 100V Rectifier Diode
060413	**	220E 5W 10% Resistor
030560	**	4700u 80v 20% Snap-In Electrolytic Capacitor
667738	*	Amplifier Panel/Chassis
SMS235001	*	180W 230Vac Transformer (EU)
SMS235005	*	180W 115Vac Transformer (US)
110061	*	T3.15A Fuse 6.3x32mm (US)
110003	*	T3.15A Fuse 5x20mm (EU)
110614	*	Mains Socket
110285	*	4A 250Vac Bipolar Power Switch
080607	*	KBPC25 25A 200V Rectifier Diode Bridge
020491	*	100nF 10% 250Vac Polyester Capacitor
717078		Speaker Box Assembly
430083	*	PFM-12.2MA Covered Wodden Speaker Box
347396	*	Belt Handle
340270	*	25x12mm Rubber Foot
120662	*	M5 4-tips Lock Nut
120661	*	M4 4-tips Lock Nut
120455	*	4,2x9x2 Washer
120411	*	WL3.5x20tt Black Screw
120102	*	M4x30tsp Black Screw
667709		Speaker Net
659027		White Pot Knob
229043		12ohm Piezoelectric Horn Tweeter
227065		12" 8ohm Woofer Speaker
210273		Speaker Filler (400gr/m² 50x50x4cm)
210217		Black Sealer (specify mt)
180662		"Lem" Adhesive Blue Plate
120483		5mm Black Shakeproof Washer
120461		5.3X10X1 Black Washer
120414		WL3.5x35tt Black Screw
120411		WL3.5x20tt Black Screw
120364		WL3.5x12tt Black Screw
120124		M5x30tc Black Screw

PFM-15.2MA

778150		Speakers Cables Assembly
768219		PFM-15.2 4ohm Crossover Board (Pcb#313081)
210215	*	Adhesive Rubber Foam 10x1.9mm (Specify mt)
120857	*	Vertical Male Faston 6.3mm
061265	*	15E 20W 5% Wire Resistor
030095	*	2u2 100V 20% Axial Electrolytic Bipolar Capacitor
737113		250W 230Vac Power Amplifier Module (EU)
737114		250W 115Vac Power Amplifier Module (US)
SMS768009	*	Input Board (Pcb# EFB-074-H0)
SMS141000	**	XLR Female Socket
SMS110000	**	Dual Slider Switch
141102	**	6 Contacts Vert Male Connector
140217	**	Jack Slim Horizontal S-F Socket
100084	**	TL074 Quad J-Fet Operational Amplifier
080743	**	Led 3mm Wide Diffused Green
074570	**	5K 31steps Linear Potentiometer
042715	**	82K5 1/4W 1% Metalized Film Resistor
042672	**	39K2 1/4W 1% Metalized Film Resistor
042625	**	15K0 1/4W 1% Metalized Film Resistor
SMS768006	*	250W Amplifier Board (Pcb# EMB-456-60)
SMS090003	**	2SA1303 TO3P Pnp Transistor
SMS090002	**	2SC3284 TO3P Npn Transistor
SMS090001	**	TIP42C TO220 Pnp Transistor
SMS090000	**	TIP41C TO220 Npn Transistor
110316	**	Relay 24V / 1 Switch no 16A 250V
100061	**	TL072 Dual J-Fet Operational Amplifier
090920	**	MJE802 TO126 Npn Darl Transistor
090917	**	MJE350 TO126 Pnp Transistor
090916	**	MJE340 TO126 Npn Transistor
090201	**	2N5401 TO92 Pnp Transistor
090200	**	2N5550 TO92 Npn Transistor
090194	**	BC560C TO92 LN Pnp Transistor (BC557C Equivalent)
090183	**	BC550C TO92 LN Npn Transistor (BC547C Equivalent)
090153	**	BC327 TO92 Pnp Transistor

080901	**	VTL5C4 Analog Optoisolator
080821	**	Ptc 100° PTH9L04BD222TS2F330 Murata
080156	**	1N4002 1A 100V Rectifier Diode
080103	**	1N4148 100mA 75V Signal Diode
060051	**	0E22 5W 5% Wire Resistor
030715	**	1000u 6v3 20% Vert Electrolytic Capacitor
SMS768002	*	250W Supply Board (Pcb# EMB-450-H0)
SMS090001	**	TIP42C TO220 Pnp Transistor
SMS090000	**	TIP41C TO220 Npn Transistor
SMS030000	**	2200uF 50VL 18x36mm TWSS Rubycon
110119	**	Fuse Clip 10A max (EU) (US)
080606	**	GBU8D 8A Rectifier Diodes Bridge
080292	**	16V 1W 5% Zener Diode
080156	**	1N4002 1A 100V Rectifier Diode
060413	**	220E 5W 10% Resistor
030560	**	4700u 80v 20% Snap-In Electrolytic Capacitor
SMS235002	*	250W 230Vac Transformer (EU)
SMS235006	*	250W 115Vac Transformer (US)
110614	*	Mains Socket
110291	*	16A 250Vac Bipolar Power Switch
110029	*	T4A Fuse 5x20mm (EU)
110018	*	T6.3A Fuse 5x20mm (EU)
110037	*	T6.3A Fuse 6.3x32mm (US)
110036	*	T4A Fuse 6.3x32mm (US)
080608	*	KBPC3502 35A 200V Rectifier Diode Bridge
020491	*	100nF 10% 250Vac Polyester Capacitor
717080		Speaker Box Assembly
430085	*	PFM-15.2MA Covered Wooden Speaker Box
347396	*	Belt Handle
340270	*	25x12mm Rubber Foot
120662	*	M5 4-tips Lock Nut
120661	*	M4 4-tips Lock Nut
120341	*	WL4x20tt Black Screw
120102	*	M4x30tsp Black Screw
667710		Speaker Net
659027		White Pot Knob
229043		12ohm Piezoelectric Horn Tweeter
227066		15" 4ohm Woofer Speaker
210274		Speaker Filler (400gr/m² 100x50x4cm)
210217		Black Sealer (specify mt)
180662		"Lem" Adhesive Blue Plate
120483		5mm Black Shakeproof Washer
120461		5.3X10X1 Black Washer
120414		WL3.5x35tt Black Screw
120411		WL3.5x20tt Black Screw
120364		WL3.5x12tt Black Screw
120124		M5x30tc Black Screw
120059		M4x25tc Black Screw
370534		"Lem" Adhesive Logo

Note:

Each spare part is single quantity unless otherwise specified.

Asterisk prefix explanation:

Omitted = First level spare part.

One asterisk = Second level, part of previous listed first level part.

Two asterisk = Third level, part of previous listed second level part.

Three asterisk =

Any request for not above mentioned part must encompass specific description including:

- 1) Model name,
- 2) Section name,
- 3) Module code,
- 4) Reference name,
- 5) Quantity number.