

SERVICE MANUAL

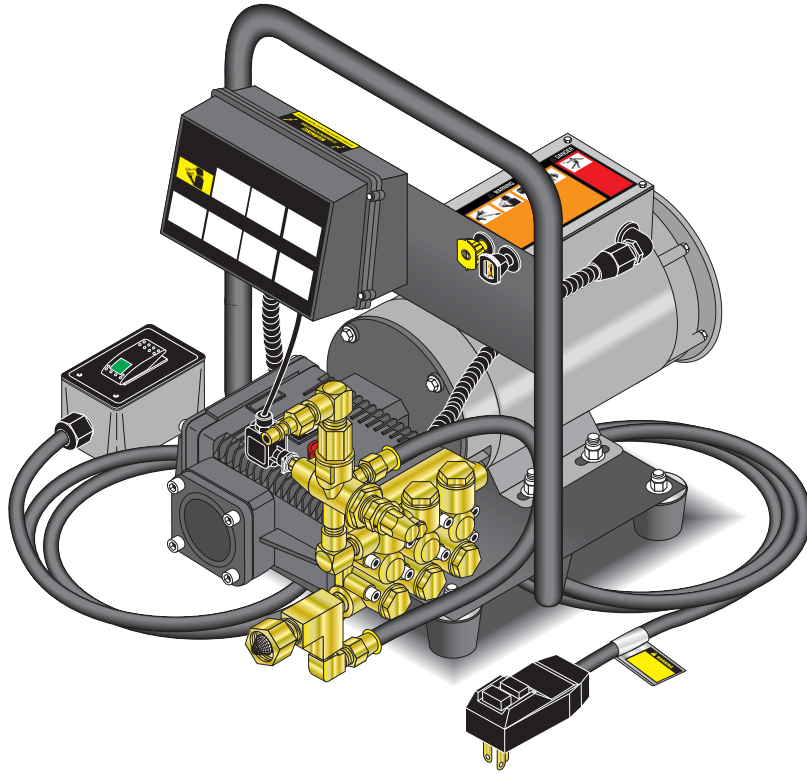

ZE2-11026D	1.106-023.0
ZE2-14024D (HOME DEPOT)	1.106-024.0
ZEF2-14024D	1.107-090.0
ET-201409Dx2	1.107-089.0
HE-201406D	1.106-066.0
HE-201006D	1.106-065.0
HE-201407D+	1.106-067.0
HD 1.8/14Ed	1.575-401.0
HD 2.0/10Ed	1.575-400.0
HD 2.0/14Ed+	1.107-088.0

Exploded View and Parts List, Standard Models	4-5
Exploded View and Parts List, ZEF, X2, Plus, and Home Depot	6-7
Control Panel, ZEF, X2, Plus, and Home Depot	8
Hose & Spray Gun	9
AXD Pump Exploded View and Parts List	10-11
E.1 Pump Exploded View & Parts List	12-13
Troubleshooting	14
Electric Diagram	15

Model Number _____

Serial Number _____

Date of Purchase _____

The model and serial numbers will be found on a decal attached to the pressure washer. You should record both serial number and date of purchase and keep in a safe place for future reference.

EXPLODED VIEW — STANDARD MODELS

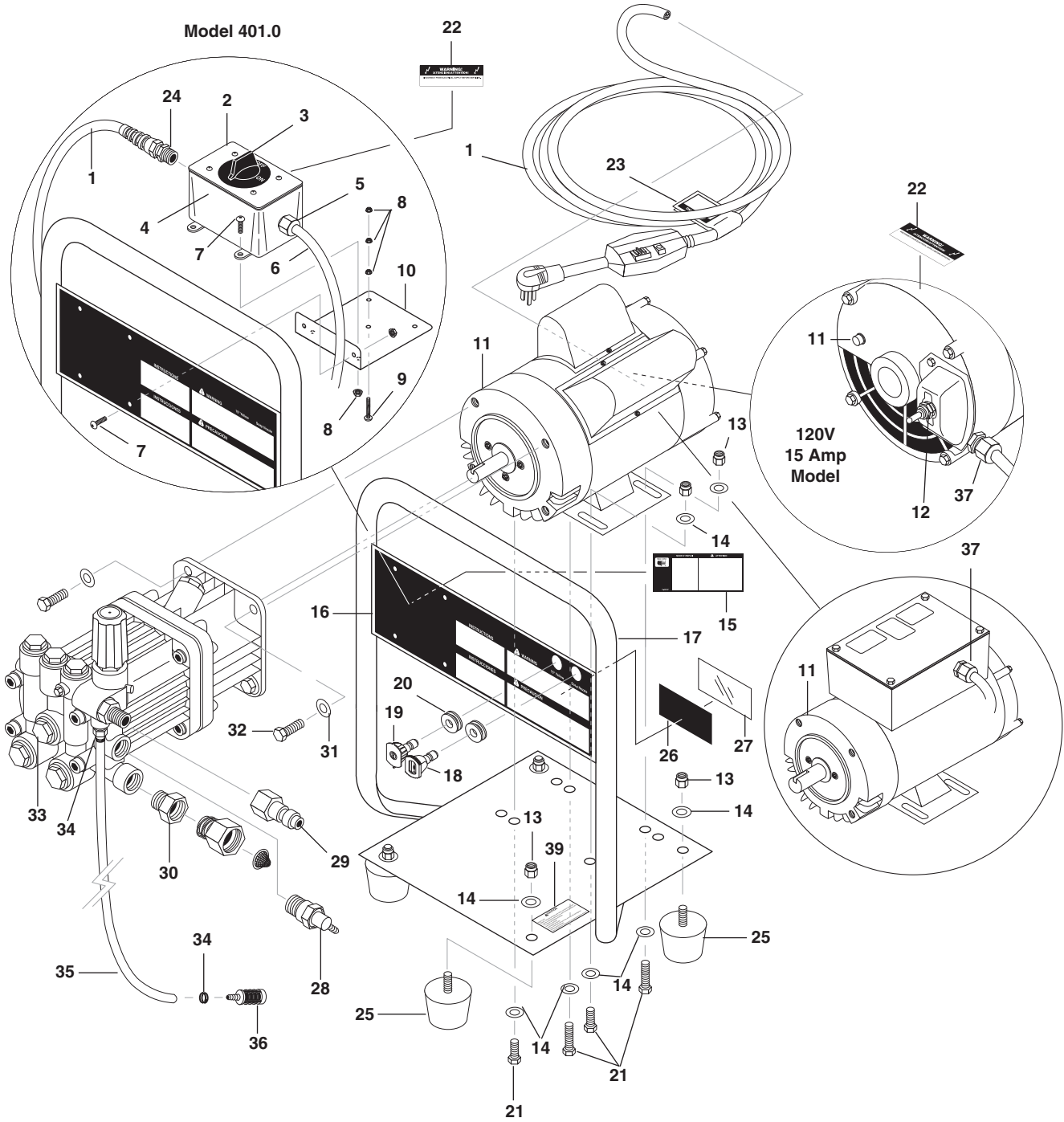

EXPLODED VIEW PARTS LIST — STANDARD MODELS

ITEM	PART NO.	DESCRIPTION	QTY	ITEM	PART NO.	DESCRIPTION	QTY
1	9.802-432.0	GFCI, 120V 15 Amp w/36' 12-3 Cord (023.0, 400.0, 065.0)	1	26	8.930-123.0	Label, For Indoor Use	1
	9.802-431.0	GFCI, 120V 20 Amp w/36' 12-3 Cord (401.0, 066.0)	1	27	9.800-034.0	Label, Clear Lexan, 2-1/4" x 4-1/2"	1
2	9.802-478.0	Lid, Plastic Carlon (401.0, 066.0)	1	28	9.802-181.0	Pump Protector, 3/8" PTP	1
3	9.802-450.0	Switch, 2 Position 120V-600V (401.0, 066.0)	1	29	9.802-170.0	Coupler, 3/8" x 3/8" NPT ST Female	1
4	9.802-477.0	Box, Plastic Carlon (401.0, 066.0)	1	30	9.802-148.0	Adapter, 1/2" x 1/2" Pipe	1
	9.800-040.0	▲ Label, Ground	1	31	9.802-807.0	Washer, 3/8" Flat SAE	4
5	9.802-518.0	Strain Relief, Strt, LQ Tite, Large (401.0, 066.0)	1	32	9.802-720.0	Bolt, 3/8" x 1", NC	4
	9.802-523.0	▲ Locknut, 3/4"	1	33	9.802-357.0	Pump, Comet AXD2020E	1
6	9.802-427.0	Cord, Service, SOWA, 12/3 (401.0, 066.0)	2 ft	34	6.390-126.0	Clamp, Hose UNI .46 - .54	2
	9.802-759.0	Screw, 10/32" x 1/2" BHSOC (401.0, 066.0)	6	35	9.802-251.0	Hose, 1/4" x 1/2" Clear Vinyl	6 ft.
8	9.802-695.0	Nut, 10/32" Keps (401.0, 066.0)	9	36	9.802-160.0	Strainer, 1/4" Barb	1
	9.802-699.0	Screw, 10-32" x 3/4" RH, SL, Black (401.0, 066.0)	1	37	9.802-514.0	Strain Relief, LT, Str, 1/2 NPT, .23-.45D	1
10	9.803-128.0	Bracket, Switch Box (401.0, 066.0)	1		9.802-525.0	▲ Locknut, 1/2"	1
11	9.802-338.0	Motor, 1.5 HP, 1 PH, 3450Rpm (023.0, 400.0, 065.0)	1	38	9.800-095.0	▲ Tag, Pump Plug/Vented Cap	1
	9.802-339.0	Motor, 2 HP, 1 PH, 3450 RPM (401.0, 066.0)	1	39	9.800-049.0	Label, Manufacturers Cleaning Solution	1
12	9.802-454.0	Switch, Toggle, Assy (400.0, 065.0)	1	▲ Not Shown			
13	9.802-776.0	Nut, 5/16" ESNA, NC	8				
14	9.802-804.0	Washer, 5/16" Flat SAE	12				
15	9.800-037.0	Label, French Warning	1				
16	9.800-059.0	Label, Instructions, Kärcher	1				
	8.750-883.0	Label, Instructions, Shark	1				
	8.900-827.0	Label, Instructions, Landa	1				
	8.900-893.0	Label, Instructions, Hotsy	1				
17	9.802-873.0	Handle Assy, Black	1				
18	(See Page 9 For Nozzles Information)						
19	(See Page 9 For Nozzles Information)						
20	9.802-064.0	Grommet, Rubber, Nozzle Holder	2				
21	8.718-618.0	BOLT, 5/16"X3/4" NC	4				
22	9.800-016.0	Label, Disconnect Power	1				
23	8.932-969.0	Label, Warning, Service Cord	1				
24	9.802-516.0	Strain Relief, 90° (401.0, 066.0)	1				
	9.802-524.0	▲ Locknut, 1/2" Conduit (401.0, 066.0)	1				
25	9.802-063.0	Mount, Vibration, 5/16"-18 x 9/16" Stud, 30 Duro	4				

EXPLODED VIEW — ZEF, x2, +, MODELS & HOME DEPOT

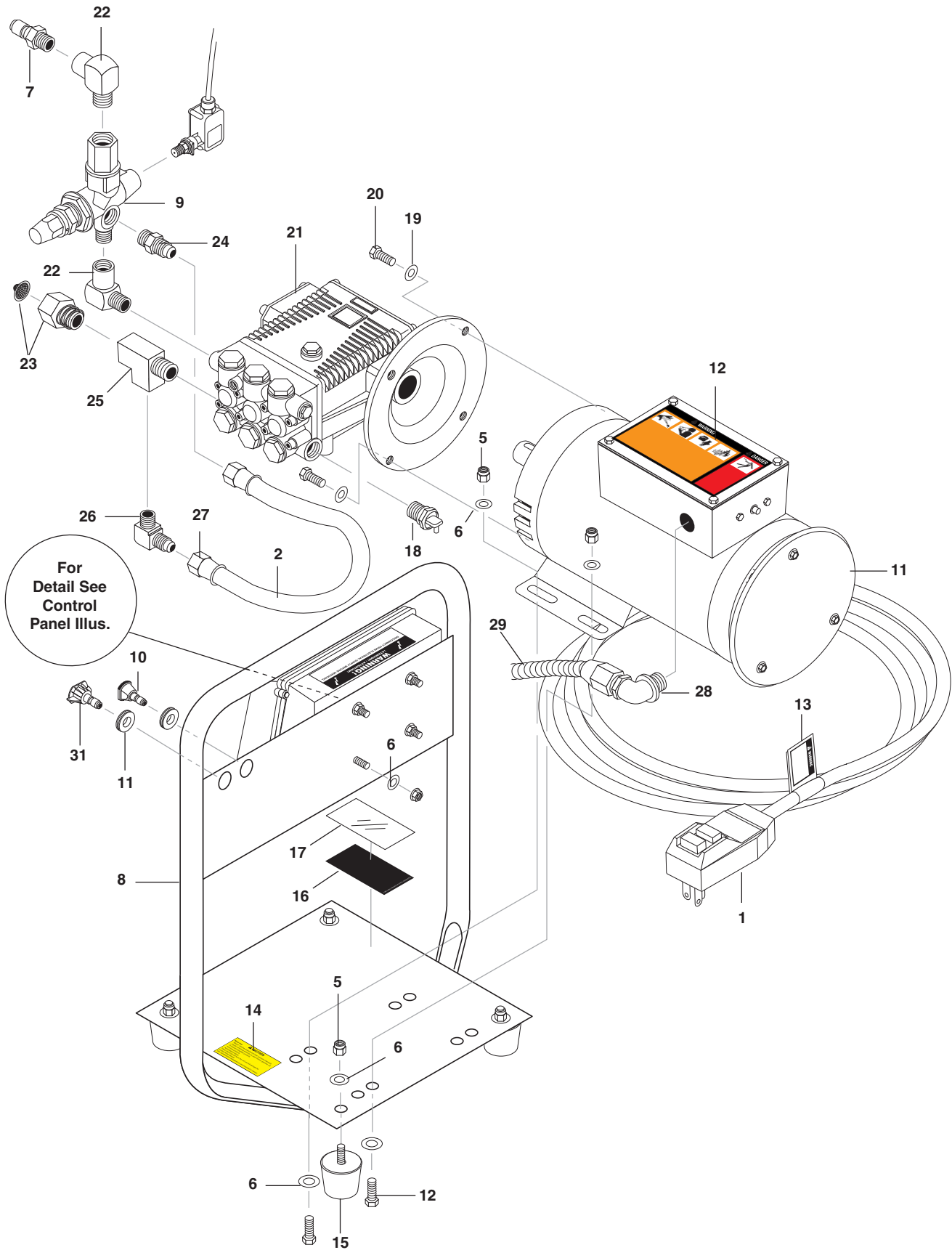

PARTS LIST — ZEF, X2, PLUS MODELS & HOME DEPOT

ITEM	PART #	DESCRIPTION	QTY
1	9.802-431.0	GFCI, 120V 20 Amp	1
2	9.802-259.0	Hose, 1/2" Push-On	15"
3	9.804-517.0	Motor, 2 HP 1Ph, 1725 RPM	1
4	8.900-305.0	Label, Warning	1
5	9.802-776.0	Nut, 5/16" ESNA, NC	12
6	9.802-804.0	Washer, 5/16" Flat SAE	16
7	9.802-171.0	Nipple, 3/8" x 3/8" Male	1
8	9.802-873.0	Handle Assy, Black	1
9	9.802-362.0	Unloader, VB8	1
10	See Page 9 For Nozzles Information		
11	9.802-064.0	Grommet, Rubber, Nozzle Holder	2
12	9.802-709.0	Bolt, 5/16" x 3/4" NC	4
13	8.932-969.0	Label, Warning, Service Cord	1
14	9.800-049.0	Label, Manufacturers Cleaning Solution	1
15	9.802-063.0	Mount, Vibration, 5/16"-18 x 9/16" Stud, 30 Duro	4
16	8.930-123.0	Label, For Indoor Use	1
17	9.800-034.0	Label, Clear Lexan, 2-1/4" x 4-1/2"	1
18	9.803-670.0	Pump Protector, 1/2" 190°	1
19	9.802-807.0	Washer, 3/8" Flat SAE	4
20	9.802-720.0	Bolt, 3/8" x 1", NC	4
21	8.904-849.0	Pump, Landa LE2020S	1
	8.904-724.0	Pump, Hotsy, HE2020S	1
	9.803-815.0	Pump, Kärcher, KE2020S	1
22	9.802-030.0	Elbow, 3/8" Street	2
23	9.802-146.0	Swivel, 1/2" GHF	1
24	9.802-127.0	Nipple, 1/2" JIC x 3/8"	1
25	9.802-122.0	Tee, 1/2" Street	1
26	9.802-131.0	Elbow, 1/2" JIC	1
27	9.802-151.0	Swivel, 1/2" JIC	2
28	9.802-517.0	Connector, 1/2" 90°	1
29	9.802-448.0	Conduit, 1/2" Water Tight	30"
30	8.715-975.0	▲ Wire, MTW 12 AWG, White	38"
	8.715-980.0	▲ Wire, MTW 12 AWG, Green	38"
	9.803-539.0	▲ Wire, MTW 12 AWG, Black	38"
31	(See Page 9 For Nozzles Information)		
32	8.900-306.0	▲ Label, HH Elec Op/Warning Combo	1
		▲ Not Shown	

CONTROL PANEL — ZEF, x2, +, MODELS & HOME DEPOT

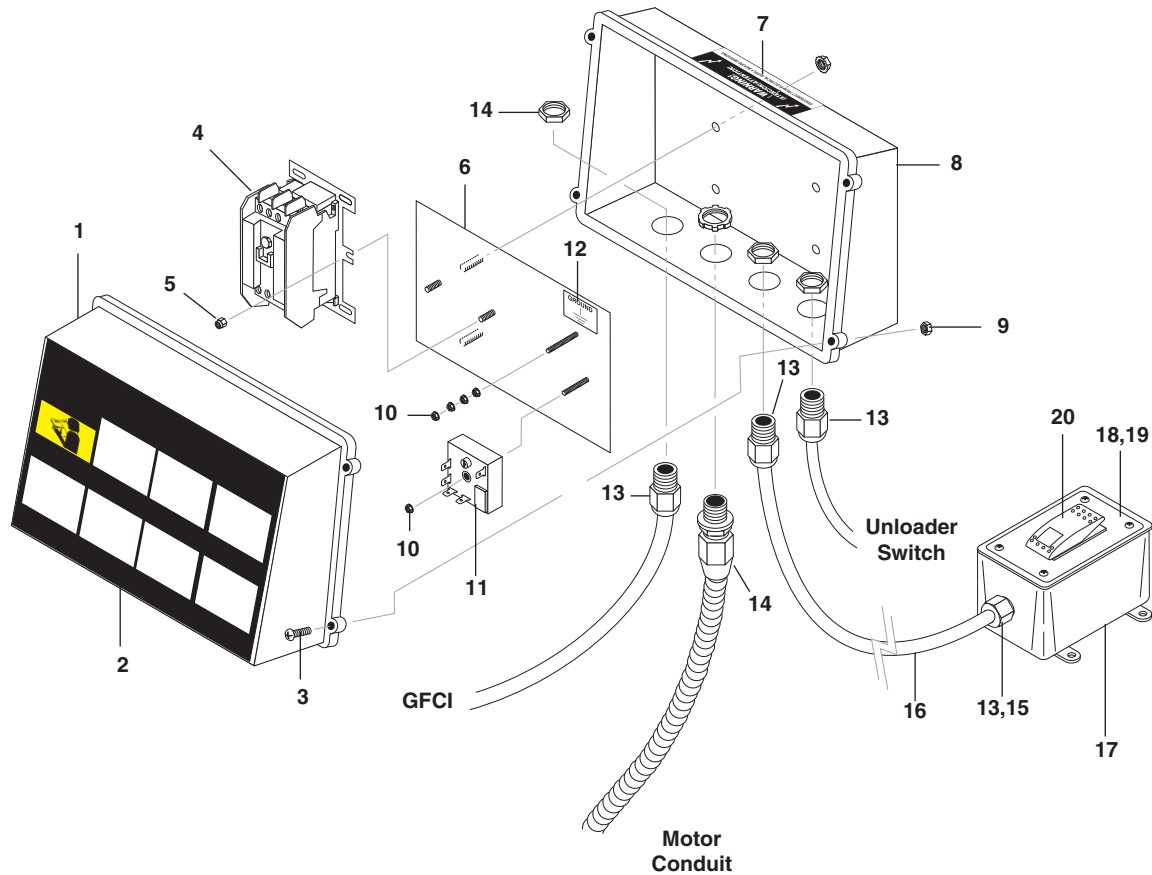

PARTS LIST — ZEF, X2, PLUS MODELS & HOME DEPOT

ITEM	PART NO.	DESCRIPTION	QTY	ITEM	PART NO.	DESCRIPTION	QTY
1	9.802-481.0	Box Front, Plastic, No Holes	1	12	9.800-040.0	Label, Ground	1
2	8.900-304.0	Label, Operation, Landa	1	13	9.802-514.0	Strain Relief 1/2"	4
	9.800-447.0	Label, Operation, Hotsy	1	14	8.716-547.0	Connector, 1/2" Straight, Black	1
	9.800-450.0	Label, Operation, Kärcher	1	15	9.802-525.0	Locknut, 1/2"	4
	8.750-882.0	Label, Operation, Shark	1	16	9.802-423.0	Cord, 16/3	10ft.
3	9.803-249.0	Screw, M4 x 10	4	17	9.802-477.0	Box, Plastic, Carlon	1
4	9.802-543.0	Contact, DP	1	18	8.900-840.0	Label, Remote Switch,	1
5	9.802-773.0	Nut, 1/4 ESNA	2	19	8.912-227.0	Plate, Remote Switch	1
6	8.911-910.0	Standoff, Elec. Box, ZE	1	20	9.802-451.0	Switch, Rocker w/Green Light	1
7	9.800-016.0	Label, Disconnect Power	1				
8	9.802-480.0	Box, Back, Plastic	1				
9	9.803-250.0	Nut, M4	4				
10	9.802-695.0	Nut, 10/32" Keps	11				
11	9.802-472.0	Timer, Solid State 120V	1				

HOSE & SPRAY GUN ASSEMBLY

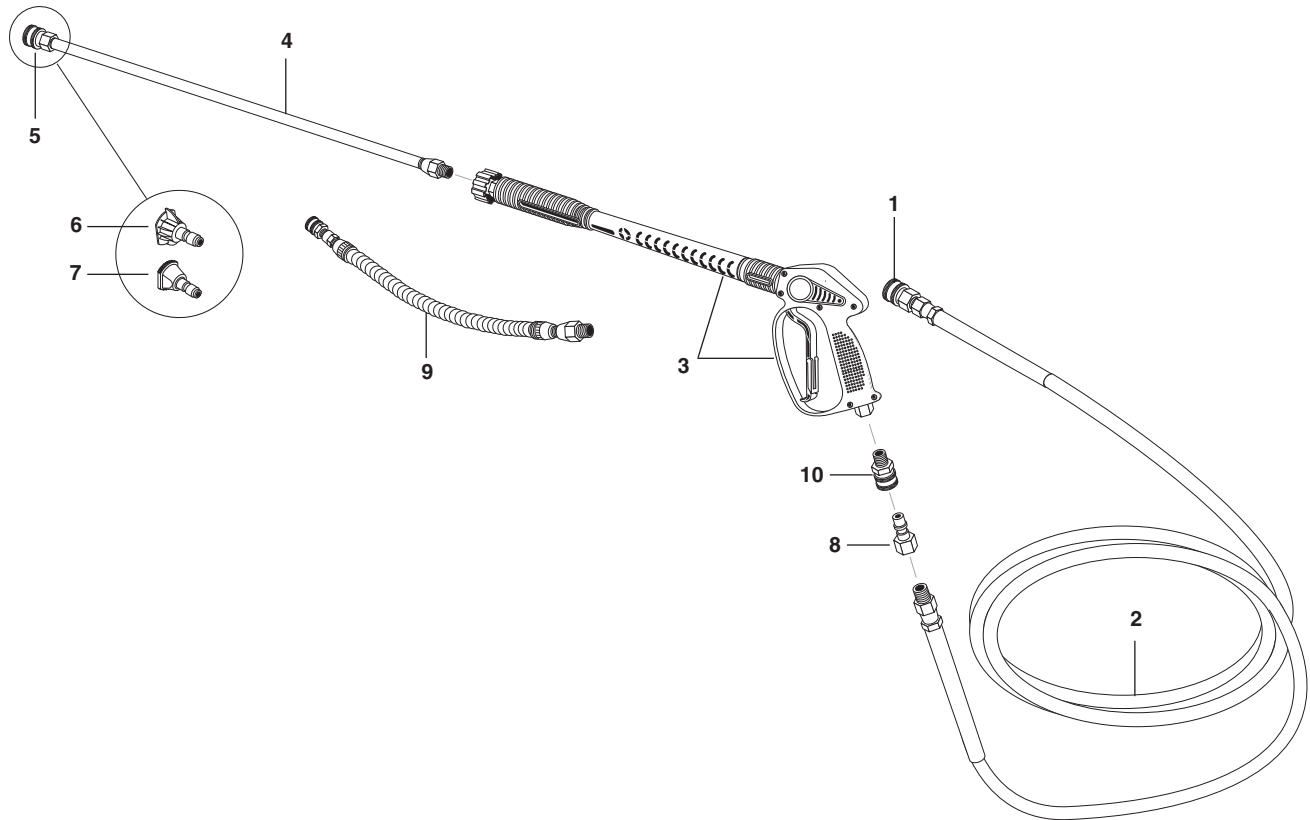

HOSE & SPRAY GUN ASSEMBLY PARTS LIST

ITEM	PART NO.	DESCRIPTION	QTY	ITEM	PART NO.	DESCRIPTION	QTY
1	9.802-166.0	Coupler, 3/8" Female	1	6	8.712-346.0	Nozzle, SAQCMEG 1504, Yellow (024.0)	1
	9.802-100.0	▲ Quick Coupler O-Ring	1		8.712-333.0	Nozzle, SAQCMEG 1503, Yellow (401.0, 066.0, 090.0, 088.0, 067.0, 089.0)	1
2	8.739-133.0	Hose, Landa 3/8" x 25', 1 Wire Tuff-Skin	1		9.804-624.0	Nozzle, SAQCMEG 150375 Yellow (400.0, 065.0, 023.0)	1
	8.739-106.0	Hose, Hotsy, 3/8" x 25', 1 Wire Tuff Skin	1	7	8.712-398.0	Nozzle Compl, QCEM-6540 Brass (Chem)	1
	8.739-124.0	Hose, Kärcher, 3/8" x 25', 1 Wire Tuff Skin	1	8	9.802-170.0	Nipple, 3/8" NPT Female	1
3	9.802-223.0	Spray Gun, Shut-Off	1	9	8.904-449.0	Flex Wand Assembly (024.0 Models)	1
4	9.802-220.0	Wand, Straight	1	10	9.802-169.0	Coupler, 3/8 Male	1
5	9.802-164.0	Coupler, 1/4" Female	1				
	9.802-096.0	▲ Quick Coupler O-Ring	1				

▲ Not Shown

AXD PUMP EXPLODED VIEW

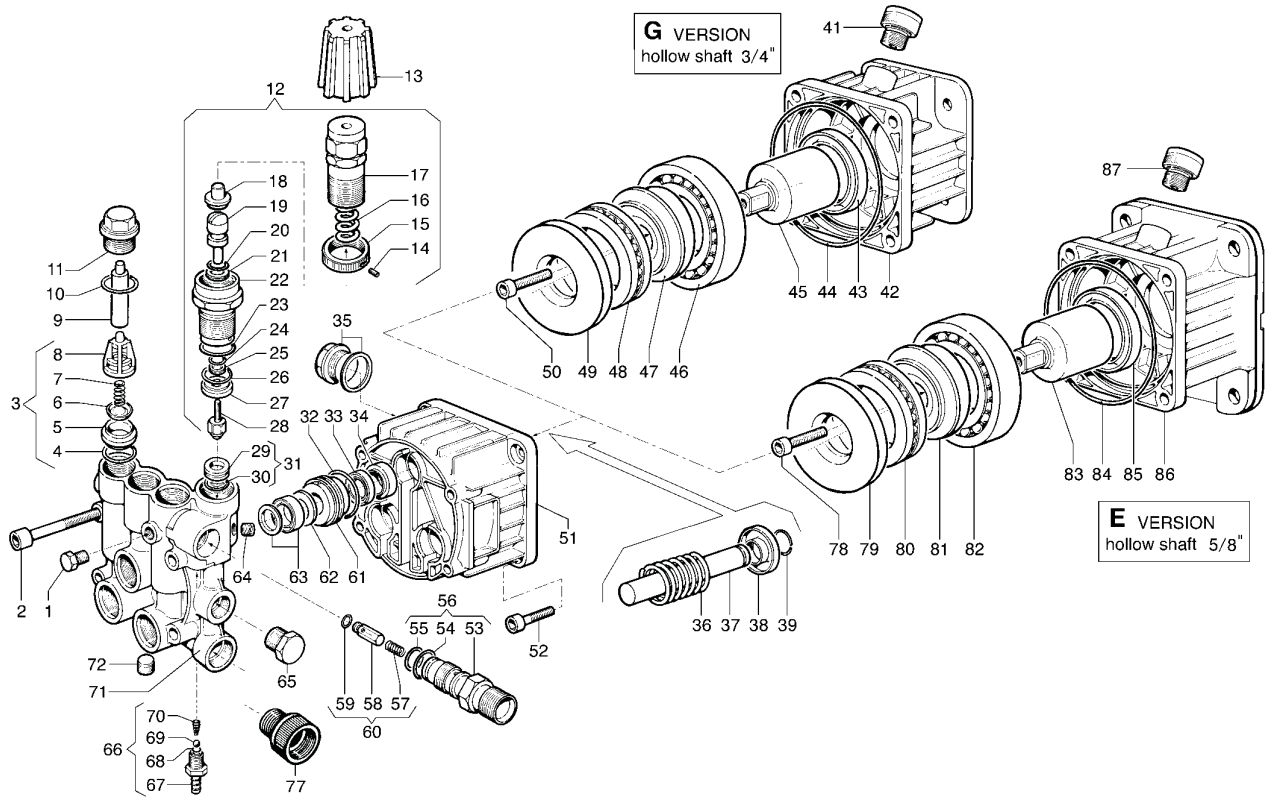

AXD PUMP EXPLODED VIEW PARTS LIST

ITEM	PART #	DESCRIPTION	KIT	QTY	ITEM	PART #	DESCRIPTION	KIT	QTY
1		Cap, 1/8"		1	23		O-Ring	E-F	1
2		Screw M8x55		4	24		O-Ring	E-F	1
3	8.721-936.0	Valve Kit		6	25		Ring	E-F	1
4	8.721-920.0	O-Ring, 1.78 x 12.42 A-D		6	26		O-Ring	E-F	1
5		Valve Seat	A	6	27		Ring	E-F	1
6		SUC/DEL Valve	A	6	28	8.721-956.0	Housing with Ball	E-F	1
7		Spring	A	6	29		Seat	E-F	1
8		Valve Cage	A	6	30		O-Ring	E-F	1
9		Spacer		2	31	8.721-957.0	Valve Seat		1
10		O-Ring, 1.78 x 17.77 A-D		6	32		O-Ring, 1.78 x 25.12 B-D		3
11		Plug		6	33	8.721-939.0	Piston Seal Ø14	B	3
12	8.721-935.0	Reg Val Kit for AX 180 Bar		1	34	8.721-899.0	Sealing Ring	D	3
13	9.841-646.0	Knob		1	35	8.721-965.0	Oil Level Plug		1
14	8.718-555.0	Stop, Adjustable Nut, M4x4	E	1	36		Spring		3
15	8.718-546.0	Nut	E	1	37	8.915-527.0	Piston	C	3
16	8.721-940.0	Spring,	E	1	38	8.721-892.0	Ring	C	3
17	8.721-906.0	Adjustable Knob	E	1	39	8.721-891.0	Ring Ø14	C	3
18		Seat	E	1	51		Pump Crankcase		1
19		Piston Rod	E-F	1	52		Screw M8x20		4
20		O-Ring	E-F	1	53		Injector Body M22 x 1.5	E	1
21		Ring	E-F	1		8.718-554.0	Injector Body, 3/8 NPT	E	1
22		Housing	E	1	54	8.721-920.0	O-Ring 1.78 x 12.42 D-E-F		1
					55		O-Ring, 1.78 x 15.6	E-F	1

AXD PUMP EXPLODED VIEW PARTS LIST

ITEM	PART NO.	DESCRIPTION	KIT	QTY
56	8.721-974.0	Injector Body Kit M22x 1.5		1
		Injector Body Kit 3/8 NPT		1
57		Spring	E	1
58		Check Valve	E	1
59		O-Ring	E-F	1
60	8.721-948.0	Check Valve Kit		1
61	8.739-570.0	Ring		3
62	8.739-571.0	Ring	B	3
63	8.739-574.0	Piston Seal 150 Bar (2520G, 3020G, 3522G)	B	3
		Piston Seal 180 Bar (3025G)	B	3
64		Plug 1/8 x 8		1
65		Plug 3/8 Gas OT58		1
66	8.718-551.0	Injector Kit		1
67		Hose Barb Fitting		1
68		O-Ring		1
69	8.739-577.0	Ball		1
70	8.739-575.0	Spring		1
71	8.718-553.0	Pump Valve Chamber		1
72		Plug 1/8 x 8		1
77		Garden Hose Tail		1

Kit A	8.721-997.0	Complete Valve Kit
Kit B	8.721-988.0	Piston Seal Kit, 150 Bar
	8.721-989.0	Piston Seal Kit, 180 Bar
Kit C	8.721-949.0	Piston Kit
Kit D	8.721-990.0	Seal Kit
Kit E	8.722-000.0	Overhaul Kit, M22 x 1.5
	8.722-001.0	Overhaul Kit, 3/8" NPT
Kit F	8.722-002.0	Maintenance Kit

E.1 SERIES PUMP EXPLODED VIEW

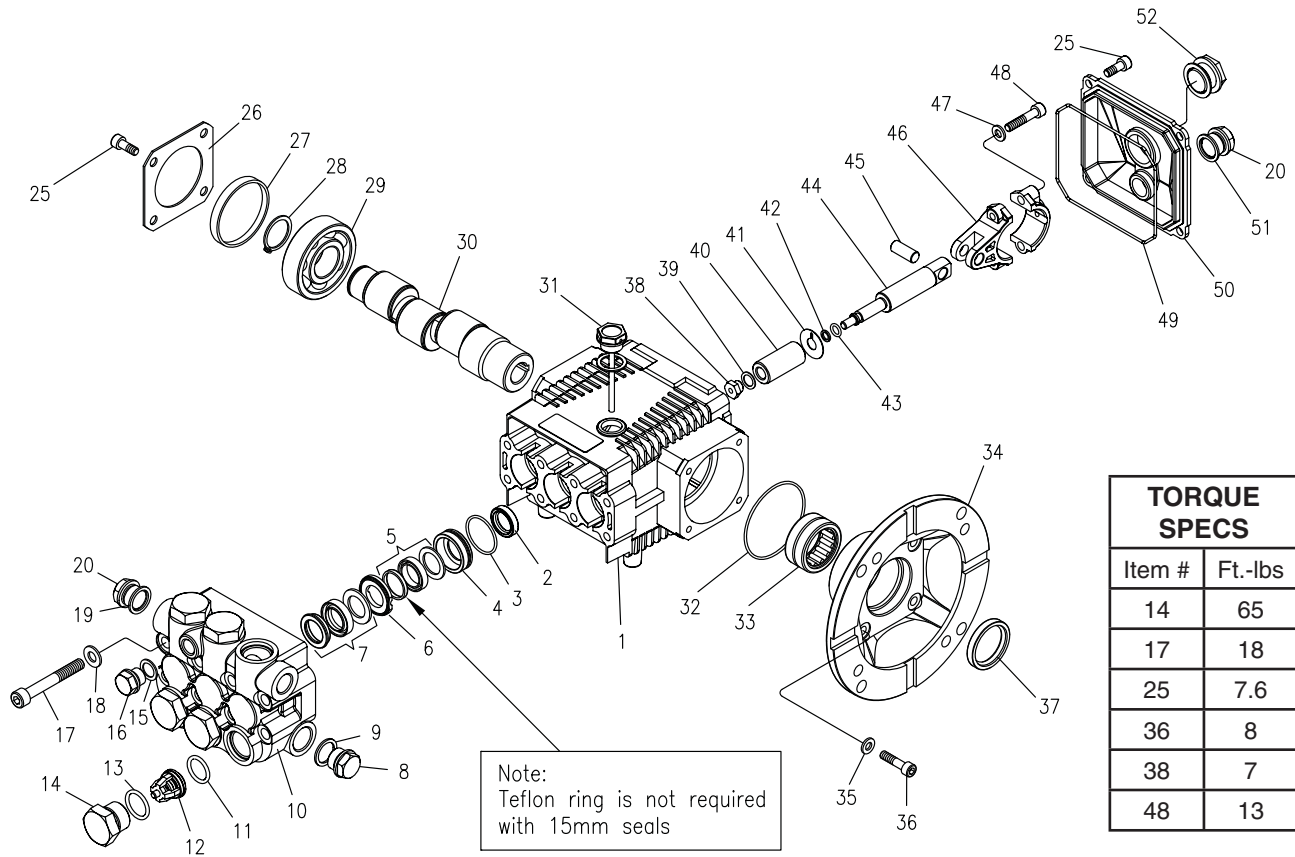

E.1 SERIES PUMP EXPLODED VIEW PARTS LIST

ITEM	PART NO.	DESCRIPTION	QTY	ITEM	PART NO.	DESCRIPTION	QTY
1	9.803-938.0	Crankcase	1	16	9.803-951.0	Brass Plug G1/4	1
2*	9.804-586.0	Plunger Oil Seal	3	17	9.803-952.0	Manifold Stud Bolt	8
3*	See Kit	O-Ring Ø 1.78 x 28.30	3	18	9.802-884.0	Washer	8
4*	See Kit	Pressure Ring 15mm	3	19	9.803-198.0	Copper Washer 3/8	1
	See Kit	Pressure Ring 18mm	3	20	9.802-925.0	Brass Plug G3/8	2
5*	See Kit	U-Seal, dia 15mm	6	25	9.802-939.0	Screw	12
	See Kit	U-Seal, dia 18mm	6	26	9.803-953.0	Bearing Cover	2
6*	See Kit	Intermediate Ring 15mm	6	27	9.803-954.0	Bearing Seal	1
	See Kit	Intermediate Ring 18mm	6	28	9.802-914.0	Snap Ring	1
7*	See Kit	U-Seal, 15mm	3	29	9.803-955.0	Ball Bearing	2
	See Kit	U-Seal, 18mm	3	30	9.804-576.0	Crankshaft (2020F)	1
8	9.802-926.0	Brass Plug G1/2	1		9.804-577.0	Crankshaft (2020S)	1
9	9.803-199.0	Copper Washer 1/2"	1		9.804-578.0	Crankshaft (2825F)	1
10	9.803-946.0	Manifold Housing	1		9.804-579.0	Crankshaft (2825S)	1
11	9.803-947.0	O-Ring Ø1.78 x 15.54	6		9.804-580.0	Crankshaft (3525F)	1
12*	See Kit	Valve Assembly	6	31	9.803-957.0	Oil Dipstick	1
13*	9.803-948.0	O-Ring Ø2.62 x 18.77	6	32	9.804-581.0	O-Ring Ø3.53 x 55.56	1
14	9.803-949.0	Valve Plug	6	33	9.804-582.0	Needle Bearing	1
15	9.803-950.0	Copper Washer 1/4	1	34	9.804-583.0	Motor Flange 56C	1
				35	9.803-210.0	Washer	4

E.1 SERIES PUMP PARTS LIST (CONT)

ITEM	PART NO.	DESCRIPTION	QTY
36	9.804-584.0	Flange Screw	4
37	9.804-585.0	Crankshaft Seal	1
38*	See Kit	Plunger Nut	3
39*	See Kit	Copper Spacer	3
40*	See Kit	Plunger 15mm (2020F, 2825F, 3525F)	3
	See Kit	Plunger 18mm (2020S, 2825S)	3
41*	See Kit	Copper Spacer	3
42*	See Kit	O-Ring Ø1.78 x 5.28	3
43*	See Kit	Teflon Ring	3
44	9.803-964.0	Plunger Rod	3
45	9.803-965.0	Connecting Rod Pin	3
46	9.803-966.0	Connecting Rod	3
47	9.803-218.0	Spring Washer	6
48	8.933-020.0	Connecting Rod Screw	6
49	9.803-969.0	O-Ring Ø2.62 x 107.62	1
50	9.803-968.0	Crankcase Cover	1
51	9.803-197.0	Gasket	1
52	9.803-202.0	Sight Glass	1

REPAIR KIT NUMBER	8.725-354.0	8.725-356.0	8.725-355.0	8.725-357.0	9.803-934.0	9.803-935.0
KIT DESCRIPTION	Plunger Seal 15mm 2020F.1 2825F.1 3525F.1	Plunger Seal 18mm 2020S.1 2825S.1	Complete Seal Packing 15mm 2020F.1 2825F.1 3525F.1	Complete Seal Packing 18 mm 2020S.1 2825S.1	Plunger 15mm 2020F.1 2825F.1 3525F.1	Plunger 18mm 2020S.1 2825S.1
ITEM NUMBERS INCLUDED	3, 5, 7	3, 5, 7	3, 4, 5, 6, 7	3, 4, 5, 6, 7	38, 39, 40, 41, 42, 43	38, 39, 40, 41, 42, 43
NO. OF CYLINDERS KIT WILL SERVICE	3	1	1	1	1	1

REPAIR KIT NUMBER	9.803-936.0	9.803-937.0
KIT DESCRIPTION	Complete Valve	Plunger Oil Seals
ITEM NUMBERS INCLUDED	11, 12, 13	2
NO. OF CYLINDERS KIT WILL SERVICE	6	3

TROUBLESHOOTING

PROBLEM	POSSIBLE CAUSE	SOLUTION
PUMP RUNNING NORMALLY BUT PRESSURE LOW ON INSTALLATION	Pump sucking air	Check water supply and possibility of air seepage.
	Check valves sticking	Check and clean or replace if necessary.
	Unloader valve seat faulty	Check and replace if necessary.
	Nozzle incorrectly sized	Check and replace if necessary.
	Worn piston packing	Check and replace if necessary.
FLUCTUATING PRESSURE	Valves worn	Check and replace if necessary.
	Blockage in valve	Check and replace if necessary.
	Pump sucking air	Check water supply connections.
	Worn piston packing	Check and replace if necessary.
	Insufficient water	Check filter and hose for breakage/clogging
PRESSURE LOW AFTER PERIOD OF NORMAL USE	Nozzle worn	Check and replace if necessary.
	Suction or delivery valves worn	Check and replace if necessary.
	Suction or delivery lines blocked	Check and clean if necessary.
	Unloader valve seat worn	Check and replace if necessary.
	Worn piston package	Check and replace if necessary.
	Water temperature excessive	Reduce to below 140° F.
PUMP NOISY	Air in suction line	Check water supply and connections on suction line.
	Broken or weak suction or delivery valve spring.	Check and replace if necessary.
	Foreign matter in valves	Check and clean if necessary.
	Worn bearings	Check and replace if necessary.
	Water temperature excessive	Reduce to below 160° F.
PRESENCE OF WATER IN PUMP OIL	Oil seal worn	Check and replace if necessary.
	High humidity in air	Check and replace if necessary.
	Piston packing worn	Check and replace if necessary.
WATER DRIPPING FROM UNDER PUMP	Piston packing worn	Check and replace if necessary.
	O-ring plunger retainer worn	Check and replace if necessary.
WATER DRIPPING FROM PUMP PROTECTOR	Water supply pressure too high (over 90 psi)	Lower water supply pressure using regulator.
	Spray gun is in the off position for over 1-2 minutes	Turn machine off if not in use for over 1-2 minutes.
OIL DRIPPING	Oil seal worn	Check and replace if necessary.
EXCESSIVE VIBRATION IN HIGH PRESSURE HOSE	Irregular functioning of the pump valves	Check and replace if necessary.
MOTOR DOES NOT START WHEN SWITCHED ON	Plug not well connected or lack of power supply	Check plug, cable and switch.
WHEN SWITCHING ON THE MACHINE, MOTOR HUMS BUT DOES NOT RUN	Main voltage is insufficient, lower than the minimum required.	Check to make sure main power supply is adequate.
	The pump is stuck or frozen	Check by turning the motor manually.
MOTOR STOPS	Tripped thermal overload due to overheating	Check that main voltage corresponds to specifications for the machine. Wait a few minutes before turning on the machine again by resetting the GFCI on the cord.

ELECTRIC DIAGRAM

