

SERVICE AND INSTALLATION MANUAL for AVALON La PETITE-X



Manufactured by:
Cafection Enterprises Inc.
2355, Dalton, Quebec, (Quebec) G1P 3S3 Canada
Tel.: 1-800-561-6162 Fax: 1-800-463-2739
avalon@cafection.com www.cafection.com

Revision 6

Table of Contents

1	INTRODUCTION	5
2	SAFETY INSTRUCTIONS.....	6
3	WARRANTY	7
3.1	Warranty Policy	7
3.2	Returning Products	7
3.3	Returned Product Procedures	8
4	REFERENCE DRAWINGS.....	9
4.1	External View.....	9
4.2	Rear View	10
4.3	Internal View	11
4.4	Membrane Keypad	12
4.5	Brewer Assembly	13
4.6	Brewing Process	14
4.7	Hot Water Tank	15
4.8	Main Board (PCB).....	16
4.8.1	Main Board (PCB) Descriptions.....	17
5	CONTROLS & FEATURES.....	18
5.1	Features & Benefits	18
5.2	Specifications.....	19
5.3	Automatic Safety Features.....	20
5.4	Brewing Instructions	21
6	INITIAL SETUP	22
6.1	Installation site requirements	22
6.1.1	Clearances	23
6.2	Unpacking	24
6.3	Levelling the Equipment.....	25
6.4	Hot Water Tank Preparation	25
6.4.1	Tank Lid Preparation.....	25
6.4.2	Adjusting the Tank Overflow Float	26
6.5	3 Beans canister installation	26
6.5.1	Install the 3 Beans Canister	26
6.5.2	Lock the 3 Bean canister.....	27
6.5.3	Install the Plastic Top fitting part.....	27
6.5.4	Install the Plastic Top	27

Table of Contents Continued

6.6	Water Line Connection	28
6.7	Electrical Connection	29
6.8	Water Temperature.....	30
6.9	Loading Products.....	31
6.10	Chute System Installation	32
6.11	Filter Paper Installation	33
6.12	Installation Testing.....	34
7	SERVICE SOFTWARE.....	35
7.1	Configuration:	35
7.1.1	Dictionary	36
7.2	Product Configuration	36
7.3	Counter Display.....	41
7.4	Counter Tracking Sheet.....	42
7.5	Setting Tracking Sheet	43
7.6	Programming chart.....	44
8	CLEANING AND SANITIZING.....	45
8.1	Cleaning and Sanitizing Instructions	45
8.2	Recommended Cleaning Tools	45
8.3	Cleaning and Sanitizing Schedule.....	46
8.4	Overall Cleaning	47
8.5	Exterior Cleaning	47
8.5.1	Cleaning the drip tray	47
8.5.2	Emptying the waste bin	48
8.6	Interior Parts Cleaning & Sanitizing	49
8.6.1	Coffee Canisters.....	49
8.6.2	Soluble Canisters.....	50
8.6.3	Coffee Brewer.....	51
8.6.4	Fan.....	52
8.6.5	Stainless coffee chute	53
8.6.6	Plastic chute of the 3 bean canister	54
9	PREVENTIVE MAINTENANCE	55
9.1	Preventive Maintenance (PM) Schedule	55
9.2	Brewer Assembly	56
9.3	Water Outlet Valves	57
9.4	Hot Water Tank	58
10	SERVICING PARTS	59

Table of Contents Continued

10.1 Draining the Hot Water Tank	59
10.2 Shutdown / Storage	60
10.2.1 Storing the Brewer Assembly	60
10.3 Brewer Assembly	61
10.4 Microcontroller (EPROM)	62
10.5 Main Board.....	63
10.6 Keypad Membrane	63
11 TROUBLESHOOTING	64
11.1 “Error” Appearing on the LCD Screen.....	64
11.2 Other Message Possibilities on the LCD Screen	65
11.3 Particular Cases	66
Annex 1 Full maintenance schedule	67
Annex 2 Monthly maintenance schedule.....	68
Annex 3 Weekly maintenance schedule	69

1 INTRODUCTION

Cafection manufactures the AVALON La Petite-X Brewer based on its original Avalon single-cup technology and is complemented with the coffee of your choice!

The Avalon family of brewers are designed and engineered based on Cafection's 35 years experience in the office Coffee Service industry. This convenient, reliable and user friendly system assures fresh-tasting gourmet coffee, delicious hot chocolate and succulent cappuccinos whipped to perfection, every time, any time.

The Avalon La Petite-X brewer offers 3 choices of whole bean coffee that can be mixed with soluble products upon request as well as gourmet hot chocolate, americano and hot water.

All products are available in 2 adjustable cup sizes;
Small and Large; from 7 to 18 oz.

In the following pages, you will find clearly illustrated and easy-to-follow instructions regarding:

- Safety Instructions
- Reference Drawings
- Controls and Features
- Initial Setup
- Service Software
- Cleaning and Sanitizing
- Preventive Maintenance
- Servicing Parts
- Troubleshooting

BEFORE YOU START

These brewers have been manufactured to comply with the highest sanitation, safety and performance standards. To maintain this degree of safety and performance, it is important that the installation and maintenance be performed in accordance with the recommendations made in this service manual. Any changes to the construction or wiring can be hazardous to the user. The brewer must not be altered in any way and only genuine replacement parts from Cafection must be used for the preventive maintenance and repair.

This document refers to the specifications, parameters and user interface of the Avalon La Petite-X Brewer and may differ from the previous Avalon models.



The steps outlined in “Initial Set-Up” of this manual must be completed before plugging in the Brewer!!!

2 SAFETY INSTRUCTIONS

Basic safety precautions should always be followed when using electrical appliances. Read all instructions before using this brewing equipment.

Food-Contact Parts

We recommend that you clean and sanitize all food-contact parts prior to installation and use. See the cleaning and sanitizing section for more details

Warnings

- To minimize the risk of fire or electric shock, do not expose this equipment to rain or moisture.
- Do not immerse this equipment in water; it could lead to electric shock or other malfunctions.
- Do not use this equipment other than for its intended use.
- This equipment contains hot water; never move when full.
- This brewing equipment is intended for indoor installation only.

Power supply

- Always use a grounded 120V AC 60Hz socket outlet rated for 15A service.
- Each brewing equipment must have its own electrical outlet, on a dedicated circuit.
- Extension cords must not be used.
- This equipment is equipped with a polarized alternating current line plug (one blade wider than the other). Only use this plug with an outlet in which the prongs can be fully inserted. Avoid any exposure of the prongs on the polarized plug.

Disconnect the equipment if:

- Damage is done to the power cord;
- The equipment doesn't work properly;
- The temperature of the power cord or plug increases dramatically during use;
- Unusual conditions occur.



FAILURE TO COMPLY CAN CAUSE EQUIPMENT DAMAGE, FIRE OR SEVERE BODY INJURIES.

3 WARRANTY

Procedures and Conditions for Goods Returned

All warranty claims and products returns processed by our technical department is available Monday through Friday from 8:30 to 16:30 eastern time or alternatively by email service@cafection.com

3.1 Warranty Policy

Cafection provides a warranty period as follow unless otherwise confirmed in writing:

- All parts **in contact with water** (release valve, heating element, thermostat, probe, valve water inlet and tank fleet) **3 months after the invoice date.**
- All other parts of the coffee brewer: **12 months from the invoice date.**

The warranty covers any malfunction due to manufacturing defects and does not cover defects resulting from negligence, improper installation or misuse of the product or equipment failure due to excessive mineral deposits or the quality of local water. **Any damage, alteration of serial #, date or codes will void the warranty.**

Obtaining a Return Merchandise Authorization number (RMA)

Before obtaining a return number, you should first contact our Technical Department to discuss the disruption and confirm that the product should be returned for further testing.

You will need to provide the following information:

- Company name and contact;
- Invoice #, product #;
- Quantity;
- Serial #;
- Detailed description of the problem.

Our Technical Department will then send you a return form with an RMA number and product (s) authorized for return.

The return numbers are valid for **30 days after the date issued.** Any RMA number over 30 days must be revalidated with our Technical Department.

3.2 Returning Products

After obtaining a RMA number, you must ship the product or products to the following address:

Cafection Enterprises Inc.
Attn: Service Department
2355 Dalton
Quebec (Quebec) G1P 3S3
Canada

The return shipping charges will be assumed by us for products guaranteed (only under authorization of the Technical Department). If we paid for the transportation and the product is not covered under warranty, you will be charged back the freight.

All products must be packaged carefully to avoid damage during transportation. Whenever possible, please use the original packaging. Any product damaged in transit or received in unsatisfactory conditions will not be covered by the warranty.

Cafection will not be held responsible for any loss or damage incurred during shipment.

All products must be accompanied by the return form with the valid return number and the return number must be clearly indicated on the outside of the package.

3.3 Returned Product Procedures

The RMA number does not guarantee the product will be accepted under guarantee.

Depending on the nature of the problem, after testing the defective product, we will authorize the repair or replacement by identical or equivalent specifications. It will then be determined whether there will be full or partial refund of the product.

If the product is no longer covered under warranty or returned damaged, we can get your item repaired or replaced at a price that will be determined depending on the product.

If the product is returned in unsatisfactory conditions, it will be subject to management fees of \$35 and the guarantee may be refused.

All returned products involving no malfunction will be subject to administrative fees and test of \$35, plus the freight charges associated with the return.

Advance Replacement

You can also request an advance replacement. In this case, it will be necessary to send an order for the anticipated replacement and follow the procedure explained above to return the defective product. You will receive an invoice for the advance replacement.

After testing, if the product is found defective, we will send you a credit.



Cafection Enterprises Inc
2355, Dalton
Quebec, (Quebec) G1P 3S3 Canada
Tel.: 1-800-561-6162
Fax: 1-800-463-2739
E-mail order@cafection
www.cafection.com

Cafection is committed to providing prompt and efficient service and an excellent customer service. Our intention is to process all returns within 15 days after the date of receipt to ensure the ongoing satisfaction of our customers.

Last update, March 2010, G.A.

La Petite-X Revision 6 01/2015

4 REFERENCE DRAWINGS

4.1 External View

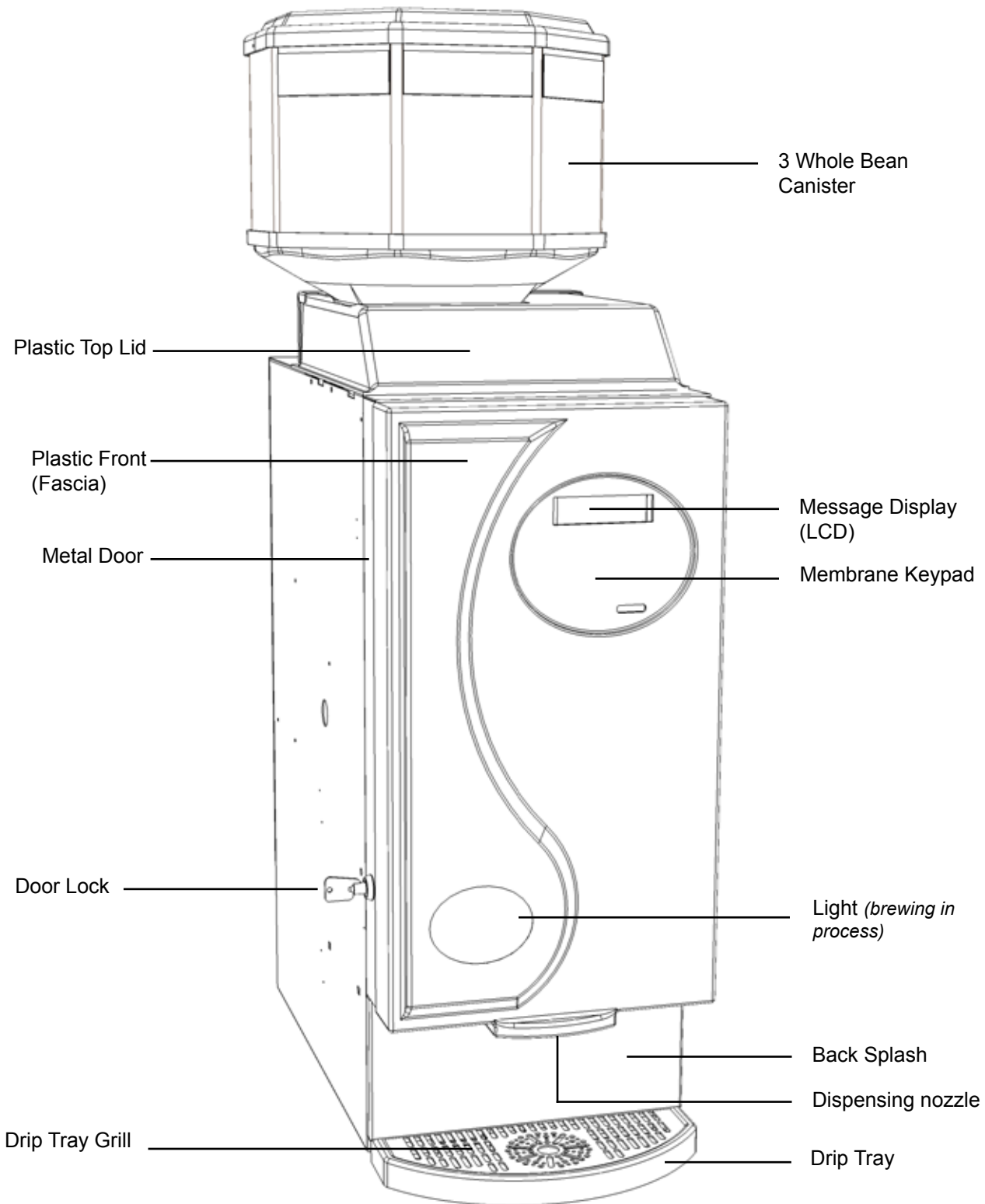

4.2 Rear View

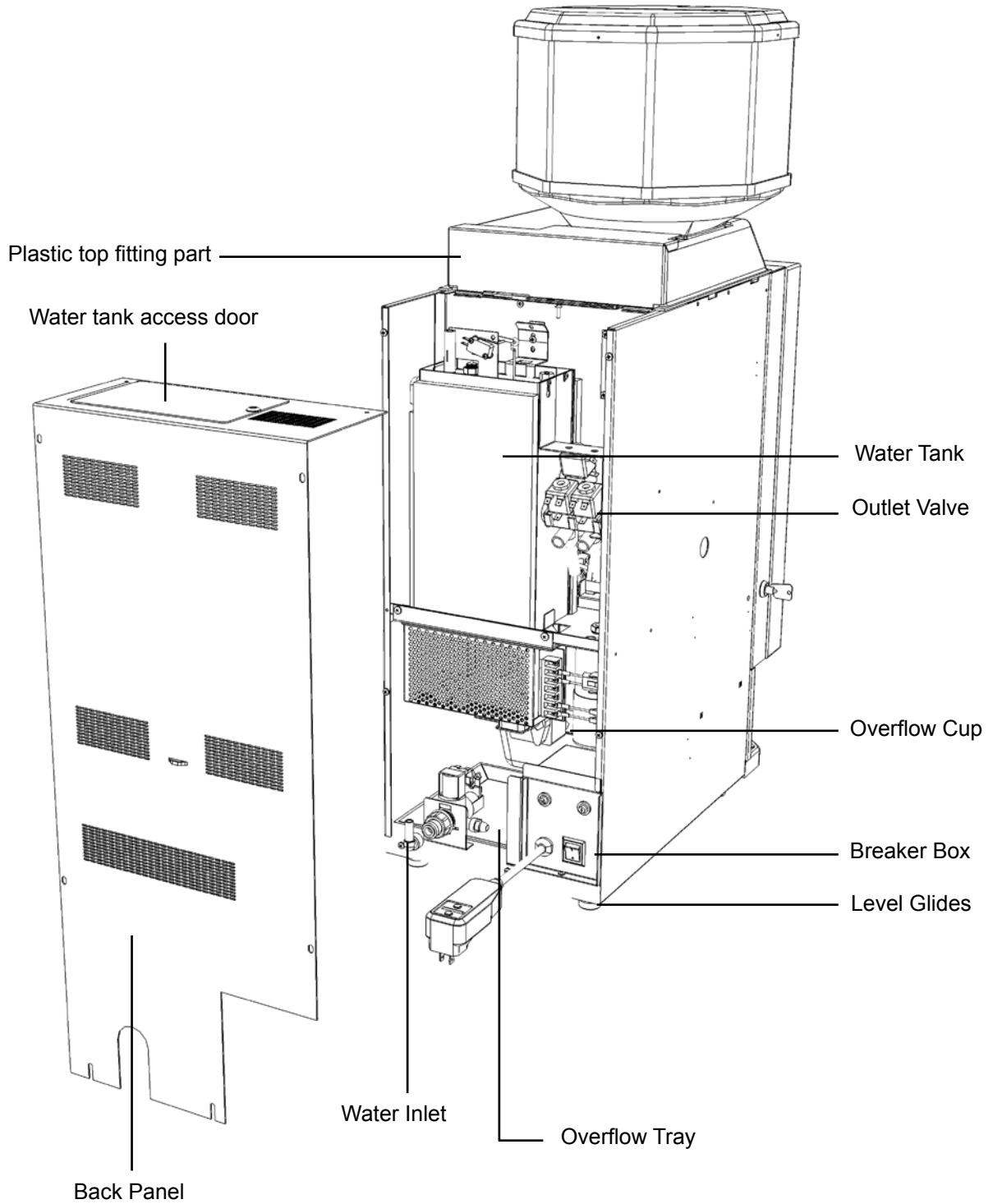

4.3 Internal View

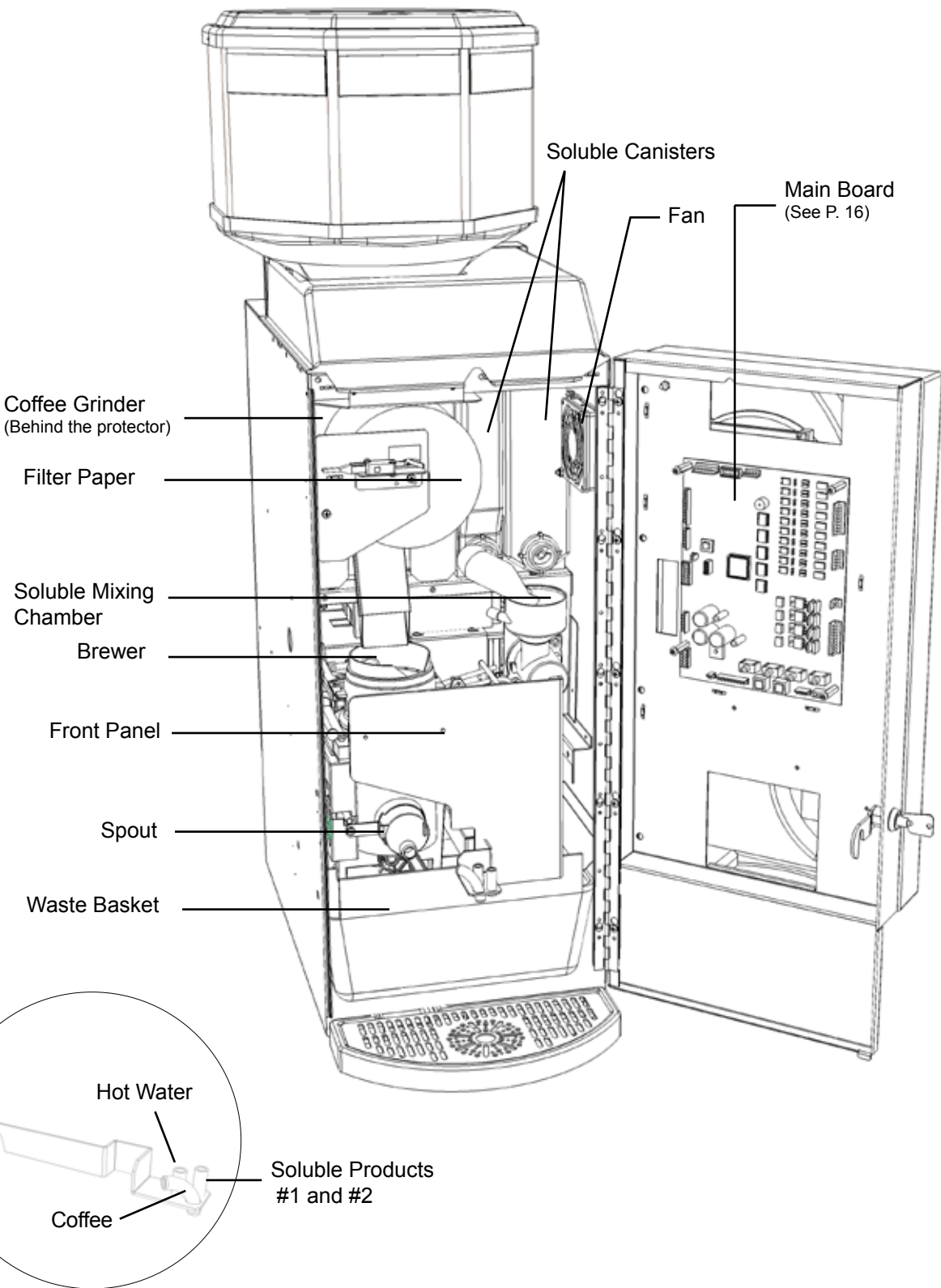

4.4 Membrane Keypad

The user-friendly membrane keypad buttons are clear and simple:

1. Place your cup
2. Choose a size
3. Choose a beverage
4. Choose your strength
5. Press Start to brew

The LCD will indicate the steps and communicate messages.

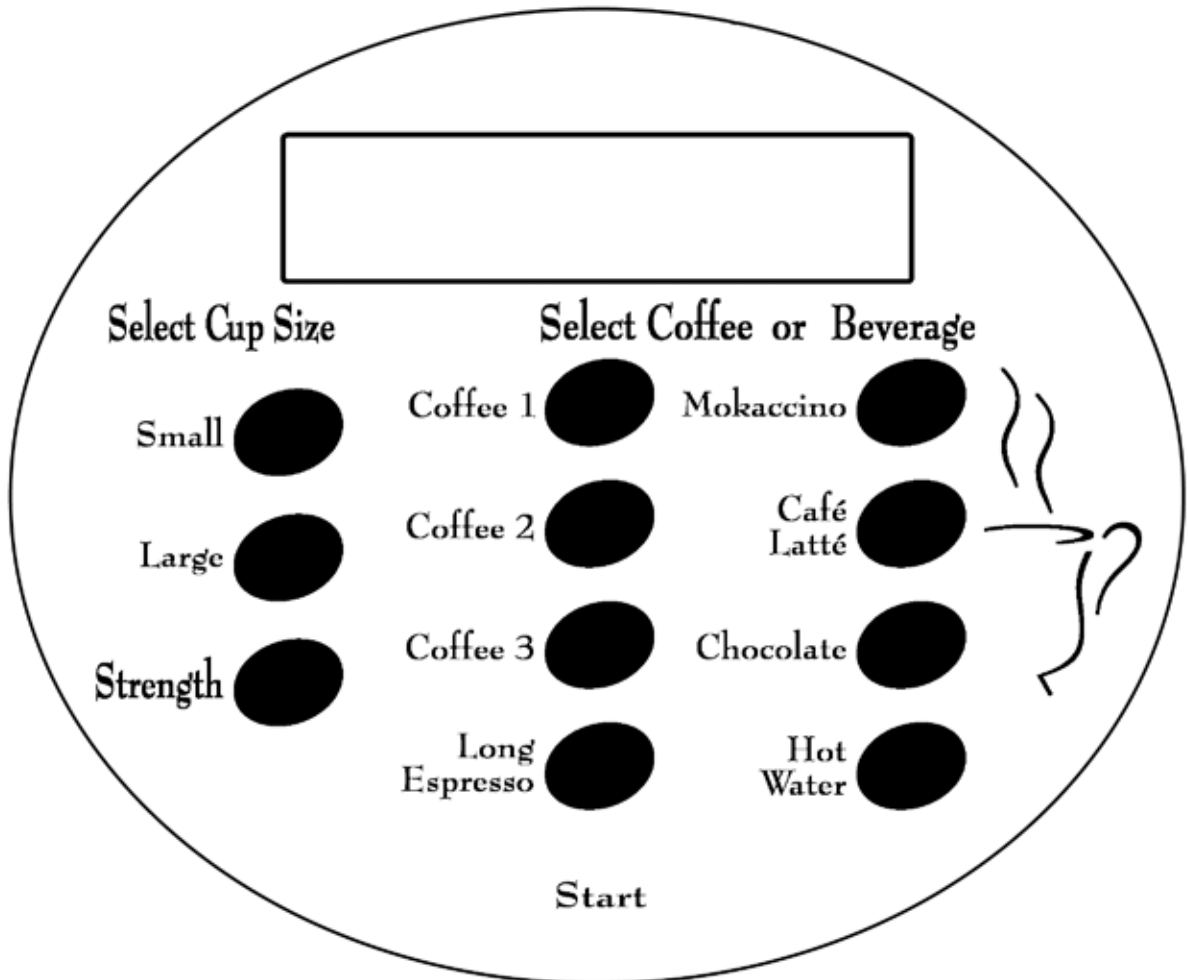

4.5 Brewer Assembly

The platinum brewing system is in a class of it's own in the single cup coffee business and is specifically designed for Avalon units. Its vacuum extraction process, joined with a high quality filter paper, brews a coffee of unsurpassed quality to meet the taste profile of the most discerning coffee drinkers. Best of all, this is available for every cup of coffee at any time of day. See the following page for the description of the brewing process.

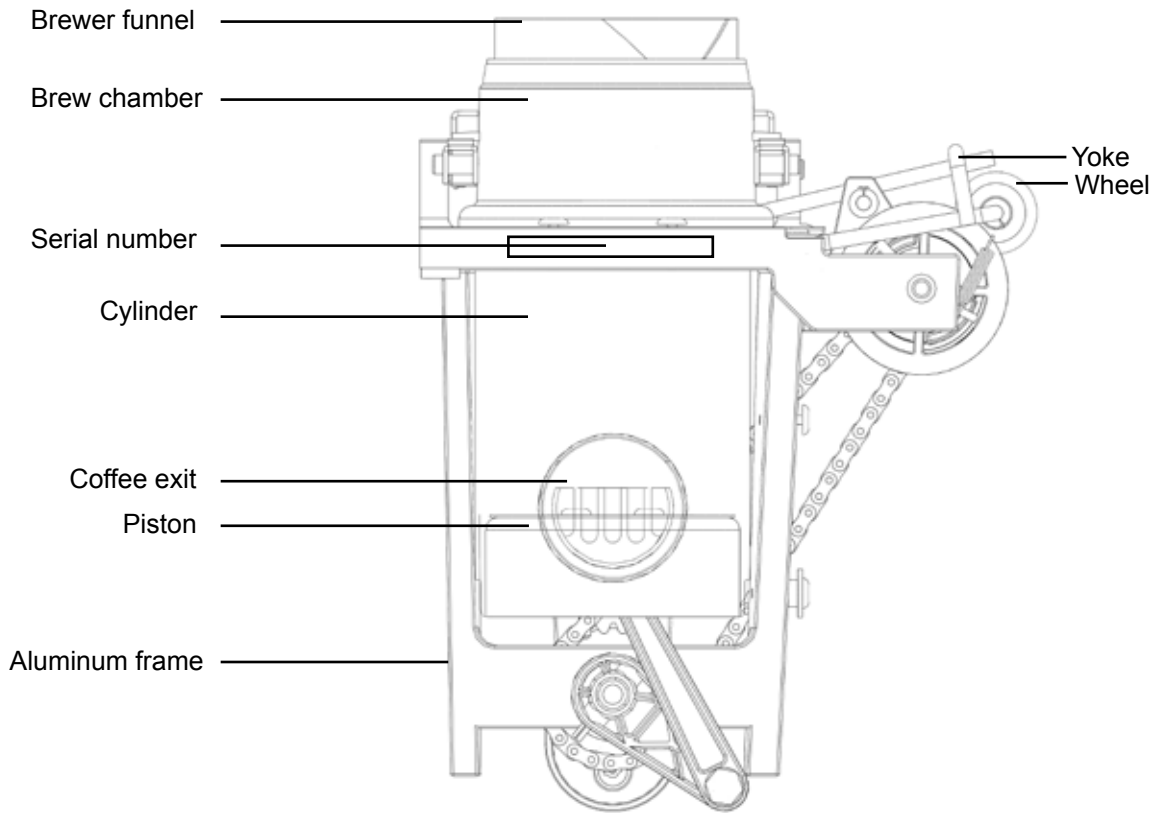

4.6 Brewing Process

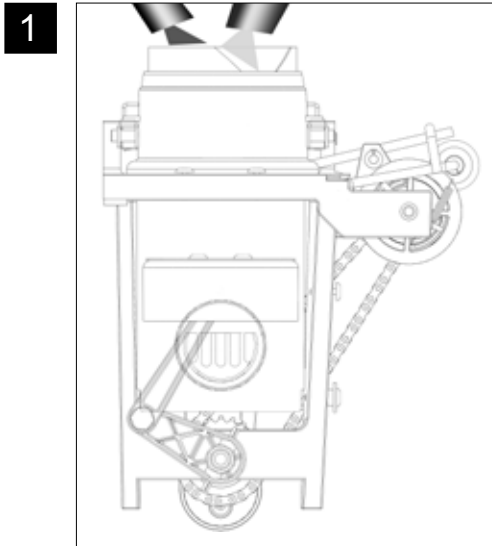

Step 1 Ascent of the piston

The ground coffee and the water are dispensed into the brew chamber during the ascension of the piston. This compresses the air in the cylinder and forces it through the coffee mixture in the brew chamber thereby agitating the brewing coffee.

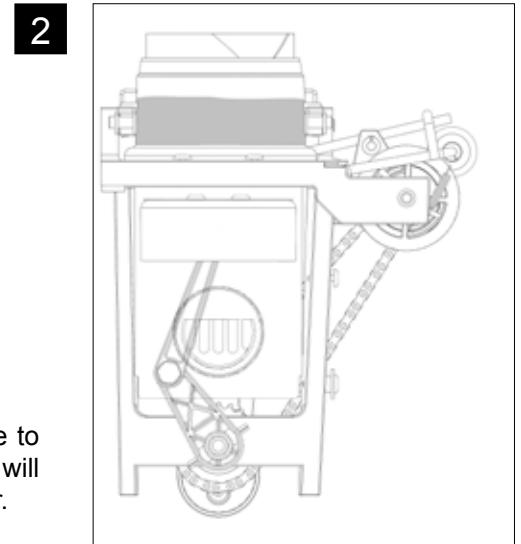

Step 2 Pauses

Once the piston has reached its top dead point, it will pause to allow the coffee to brew to the appropriate strength. There will be one shot of water before the descent to rinse the chamber.

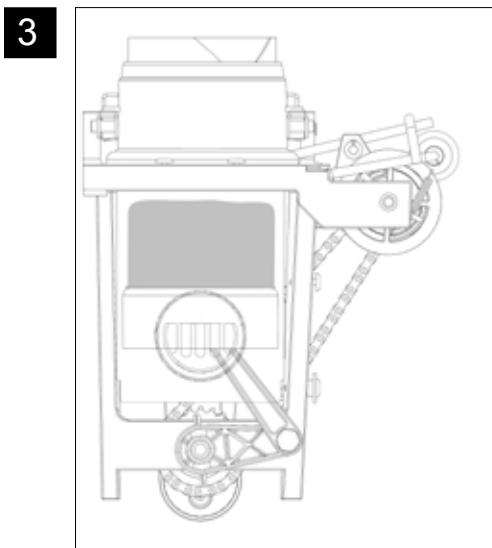

Step 3 Descent of the piston

The descent of the piston will create a vacuum thereby extracting the coffee from the grounds through the filter paper and into the cylinder. One last pause will be made to allow all the coffee to drip from the brew chamber.

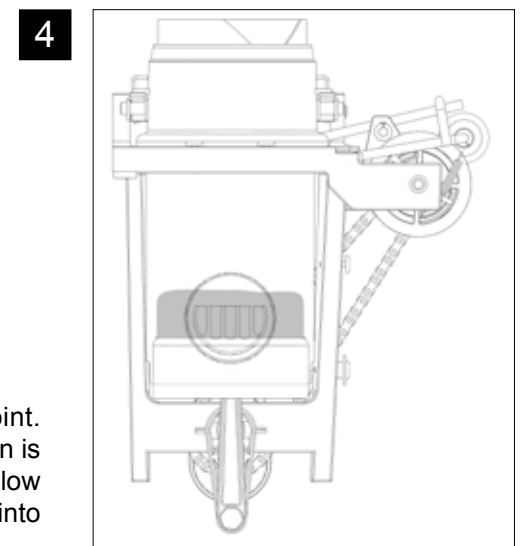

Step 4 Product delivery

The piston follows its course heading to its low dead point. Distribution of coffee through the spout begins once the piston is below the coffee exit. Meanwhile, the brew chamber lifts to allow the paper to advance thereby discarding the spent grounds into the waste chute.

4.7 Hot Water Tank

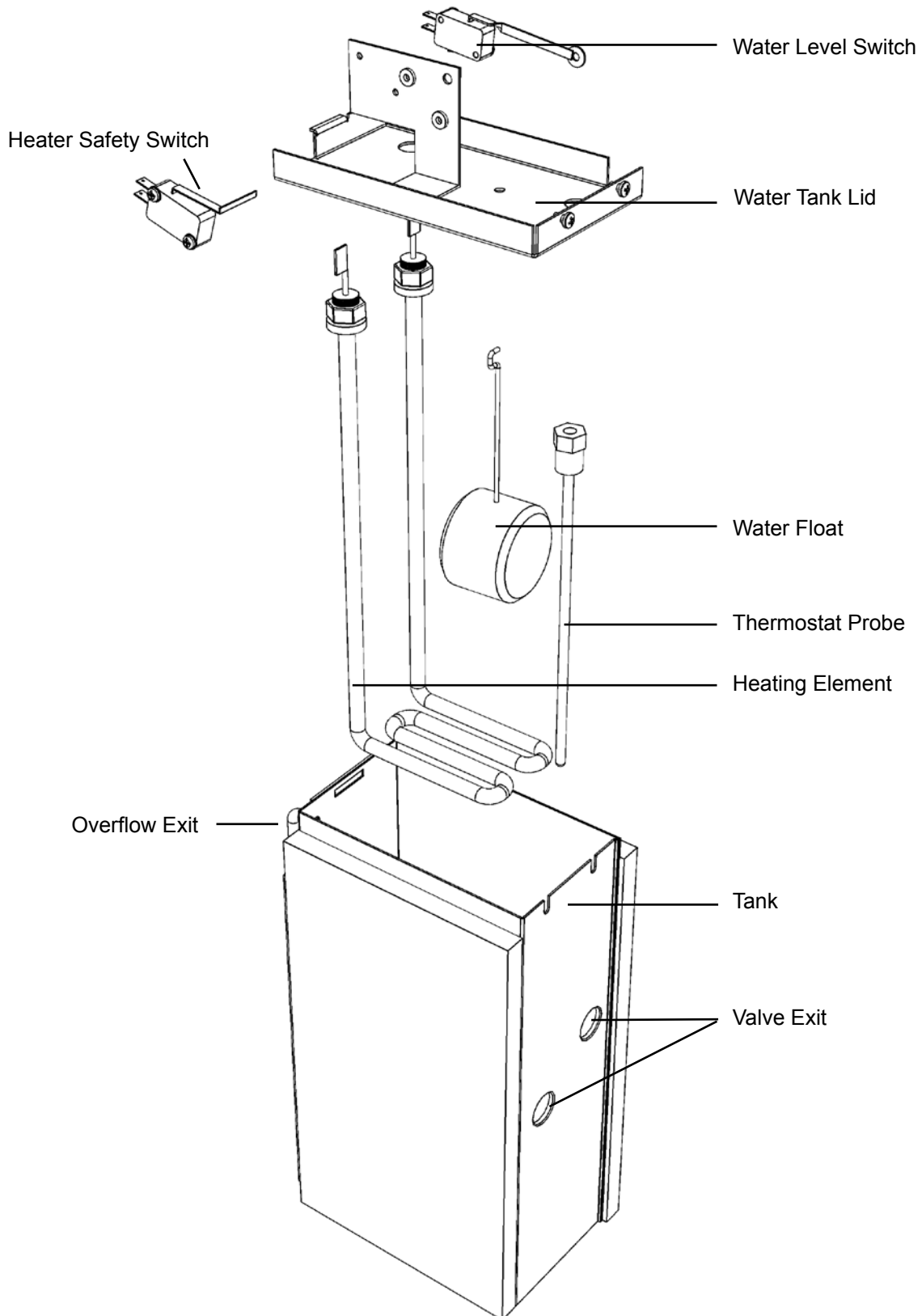

4.8 Main Board (PCB)

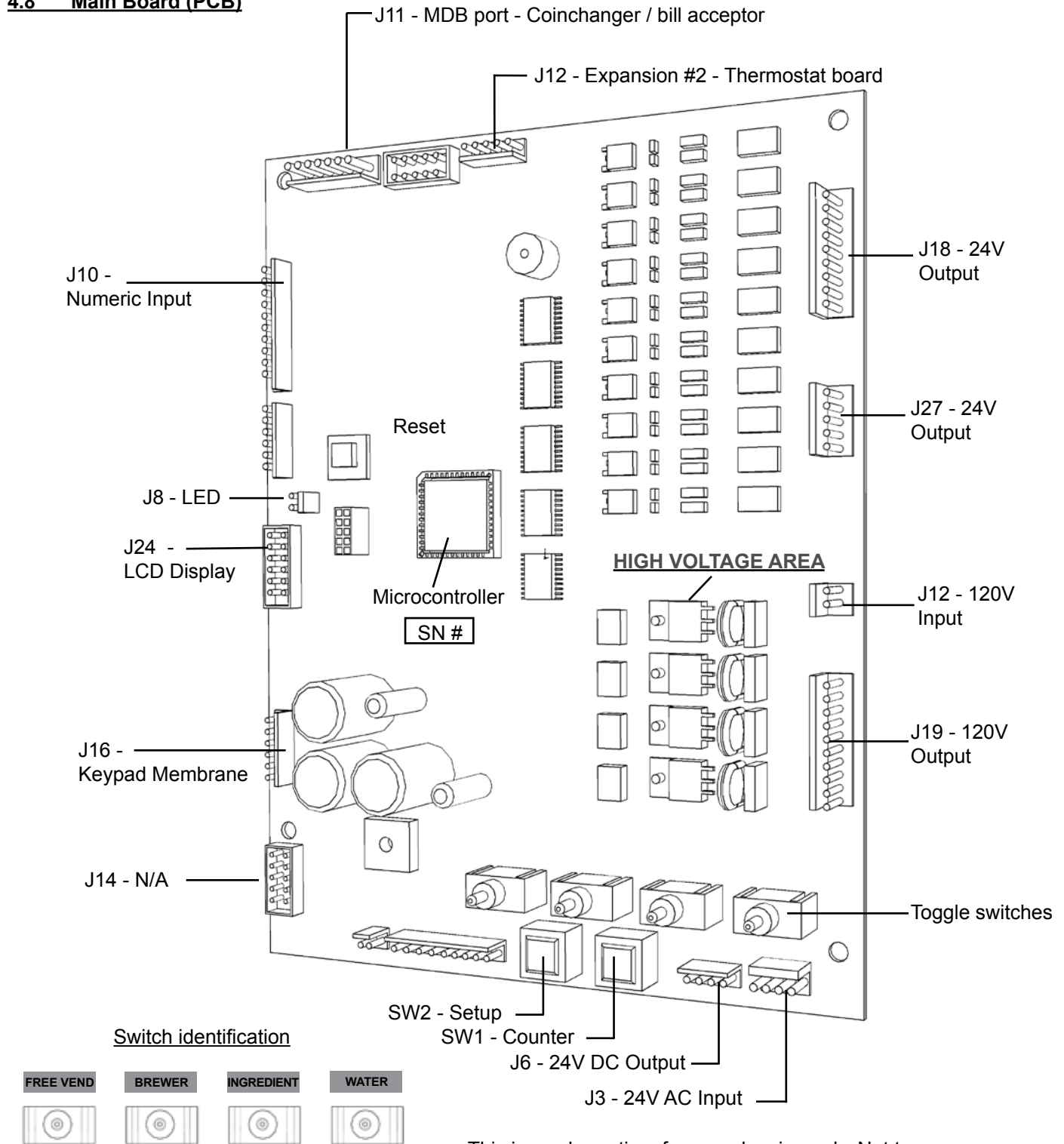

This is a schematic reference drawing only. Not to scale.

The equipment should always be unplugged from the electrical outlet before servicing any components within this main board assembly.

4.8.1 Main Board (PCB) Descriptions

Interactive switches and buttons

1. **Reset Button (Red)**
Pressing this button initializes the 3 Bean Brewer (same as the on/off switch)
2. **Counter Button (SW1) White**
Pressing this button gives you access to the tally counter data.
3. **Setup Button (SW2) Black**
Allows access to the product and brewer software parameters.
4. **Free Vend Switch (SW3)**
ON, this switch allows users to have free beverages.
5. **Brewer Switch (SW4)**
ON, the switch lifts the brewer head to allow the filter paper replacement. The switch must be in the OFF position for default user mode. This will reset the waste bin counter if activated.
6. **Ingredient Switch (SW5)**
Allows the neutralization of the ingredient dispensing motors. At OFF, the motors will not dispense ingredients.
7. **Water Switch (SW6)**
Allow the neutralization of the 3 water dispensing valves. At OFF, the valves will not dispense water.

Interactive switches and buttons Green LEDs

The green leds will illuminate to indicate the alarm that has been triggered.

- DS18** - Drip tray overflow
- DS13** - Cam switch
- DS14** - Filter paper required if OFF
- DS15** - Water level switch ON
- DS19** - Water level switch OFF
- DS16** - N/A
- DS17** - N/A
- DS20** - N/A
- DS25** - N/A
- DS27** - N/A
- DS26** - N/A
- DS24** - N/A
- DS23** - N/A

Red LEDs

The red leds will illuminate to indicate the part is in use.

- DS2** - Coffee #1 motor
- DS3** - Coffee #2 motor
- DS4** - Soluble #1 motor
- DS5** - Soluble #2 motor
- DS6** - Coffee hot water
- DS7** - Soluble hot water
- DS21** - Chute Solenoïde
- DS22** - Brewer motor
- DS10** - Inlet valve
- DS8** - Hot water
- DS9** - Brewer motor
- DS12** - N/A
- DS11** - Grinder
- DS29** - Whipper
- DS31** - Coffee #3

5 CONTROLS & FEATURES

5.1 Features & Benefits

We understand the need for individuality, that's why we offer you all the possibilities, and you choose the coffee - whether you prefer organic coffee, big brand names or locally roasted coffee, that choice is yours with Avalon.

FEATURE	BENEFIT
Electronically adjustable settings and features	Adjust the brewing settings to suit your customer's taste profile and the brand of coffee they have chosen.
3 whole bean coffee selections	Offer 3 different Whole bean coffee varieties or 3 different brands, all in one unit.
Multi-pricing capabilities	Suit all your consumers' needs - free vend, vending.
2 premium soluble selections	Experience Hot Chocolate, Mokaccino, and Café Latte whipped to perfection any time a day.
State of the art brewing technology	The brewing system is in a class of it's own in the single cup business offering an unsurpassed coffee beverage quality to meet the taste profile of the best coffee connoisseurs.
Interface	Brewing steps and selection buttons are well identified to guide the user through the ordering process.
Service software	Allows the Operator to control features of the machines, diagnostic messages and keep track of all user data.

5.2 Specifications

Beverage Selections

- 3 Whole Bean coffee selections
- Hot Chocolate
- Café Latte (Coffee of your choice + Powdered Milk)
- Mokaccino (Coffee of your choice + Hot Chocolate)
- Hot water

Canisters Capacities

Whole Bean Hopper 1: 4 lbs
 Whole Bean Hopper 2: 2 lbs
 Whole Bean Hopper 3: 4 lbs

Soluble Hot chocolate: 2.5 lbs
 Soluble vanilla powder: 2 lbs (or 1 lb of soluble milk powder)

<u>Machine Dimensions</u>	<u>Optional Stand Dimensions</u>	<u>Total Dimensions</u>
Height: 39 3/4"	31"	70 3/4"
Width: 13 1/2"	24"	37 1/2"
Depth: 23"	26"	49"

Weight: 90 lbs

Water Tank

Capacity: 0.8 gallon us (3.0 l)
 Water valves: 1 simple valve ; 1 double valve
 Heating element: 1250 watts

Electrical requirements

110 VAC
 15 A circuit
 60 Hz

INTENDED FOR INDOOR USE ONLY

5.3 Automatic Safety Features

There are various safety mechanisms on this brewing equipment to prevent a machine malfunction resulting in material damages.

Water Level Switch and Heater Safety Switch

The water level switch and the heater safety switch work together to ensure that the heating element is deactivated if there is insufficient water in the tank. The water level switch is controlled by a float and will shut off the inlet valve when the tank is full. If the level in the tank gets too low, the heater safety switch will be triggered and the heating element will be turned off.

Overflow Switch

If the water were to boil, the tank water would go into the overflow cup and all machine functions would be turned off. This is a fatal error. This could also be triggered if the float in the tank was defective or if the machine was moved while the tank was full. The unit would appear Off.

Overflow Drip Tray

This will be triggered if the drip tray is full or if something is leaking inside the unit. This will deactivate the water inlet valve thereby preventing the element to heat. The unit would indicate "Drip tray full".

Software Safety Features

At the time of the first tank fill, the water inlet valve will close after 4.5 minutes of continuous demand. This is the amount of time necessary to completely fill the tank. After the initial tank fill, the inlet valve will close after 20 seconds of continuous demand. This safety mechanism is designed to prevent water from flowing continuously into the machine due to a mechanical malfunction. The unit will indicate "Low water level"

If the low water level switch is triggered but not the heater safety switch, the element will automatically be shut off. This is in the event of a mechanical failure of the heater safety switch.

5.4 Brewing Instructions

Hi!
Make Your Choice

This screen is always on when the equipment is in the default user mode.

**Step 1: Place your cup:
Paper Cup or mug**

Make sure you verify the capacity of your cup and center it on the cup stand.

Step 2: Choose a size:

Step 3: Choose a beverage:

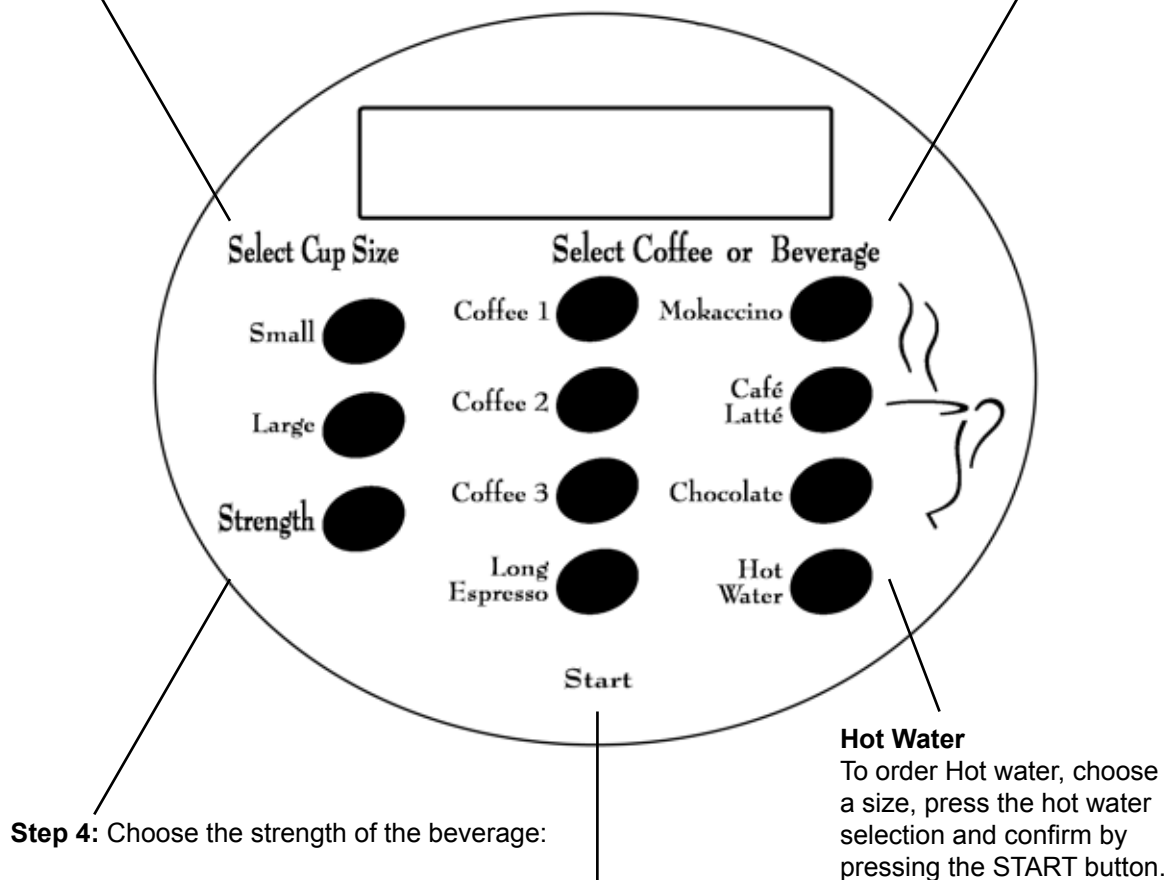

Step 4: Choose the strength of the beverage:

Step 5: Brew:

Push START to begin the brew cycle. While brewing, the brewer light will flash to indicate it is in process. No other features are available during the brewing process!

6 INITIAL SETUP

Before you install the brewer on location, we strongly suggest that it be unpacked, inspected and bench tested before you leave your warehouse.

Overview of Installation Steps

- 6.1 Installation site requirements
- 6.2 Unpacking
- 6.3 Leveling the Equipment
- 6.4 Hot Water Tank Preparation
- 6.5 3 Beans Canister Installation
- 6.6 Water Line Connection
- 6.7 Electrical Connection
- 6.8 Water Temperature
- 6.9 Loading Products
- 6.10 Chute System Installation (*optional*)
- 6.11 Filter Paper Installation
- 6.12 Installation Testing

6.1 Installation site requirements

Operating environment

For indoor use only

Power Supply

Ensure that this unit will have its own electrical circuit and located within 6 feet of the dedicated electrical outlet.

Use only a polarized grounded receptacle.

Domestic 115 VAC / 60 Hz - 15 A Circuit

Water Supply

Should be a plastic 1/4" or 3/8" O.D. dedicated line branched off a larger line. An easily accessible shut off valve up stream of the unit is highly recommended for ease of installation.

Water pressure should be at least 20 PSI and no more than 80 PSI.

Tools Required

- #2 Philips screw driver
- Regular medium pliers
- Adjustable wrench
- Level indicator



Other tools may be required depending on the type of water supply tubing and location.

6.1.1 Clearances

	Unit	Clearances	Allowance for:
Height:	39 3/4"	13 1/4"	Open the top of the machine.
Width:	13 1/2"	6"	Per side. Key access on one side and door swing on the other. <i>You need 12" clearance to open the coin acceptor (optional)</i>
Depth:	23"	11 1/2"	Front when the door is open.
		3"	Clearance of water hookup, hoses and adequate air circulation
		6"	Needed only if a filtration system is installed behind the machine

Chute

Waste chute hole position without filtration system.

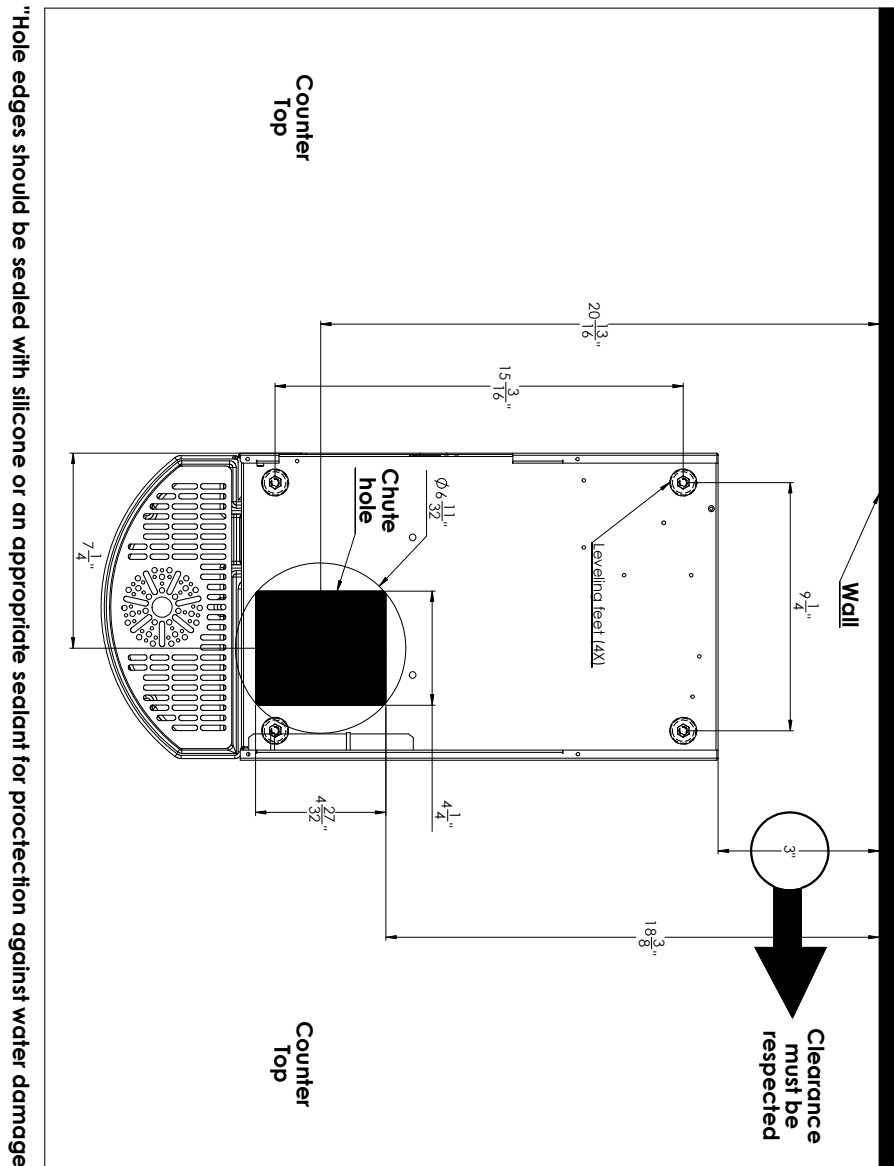

6.2 Unpacking

To remove the unit from the box, carefully cut the straps holding the box in place on the skid and then lift the box up. Inspect the unit to see if any damage has occurred in shipment.

For each brewing equipment kit you should have the following 3 boxes: the brewer, the accessories (in the brewer box) and the 3 bean canister.

The parts and accessories that are packed separately need to be installed on your equipment. In each box, you should find the following items:

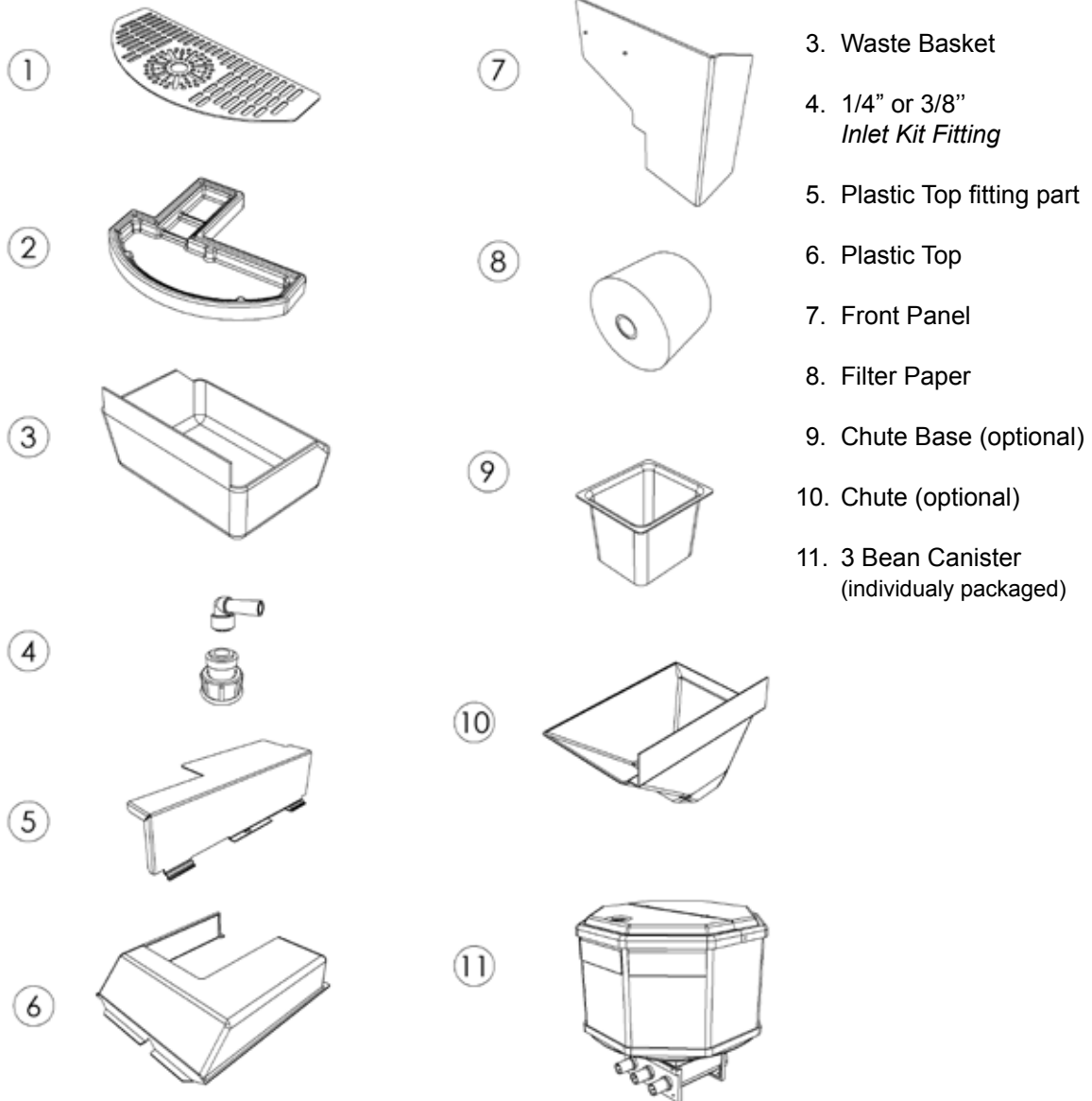

* The keys for the unit are attached to the back panel of the unit.

6.3 Levelling the Equipment

For optimal performance of the equipment, it is important to ensure that it is leveled. Avoiding to do so can create variations in product delivery.

1. Place a level on the top of the machine;
2. Adjust the 4 threaded level glides or legs of the equipment to reach a leveled position.

6.4 Hot Water Tank Preparation



MAKE SURE THE EQUIPMENT IS UNPLUGGED! FAILURE TO COMPLY CAN CAUSE EQUIPMENT DAMAGE OR INJURIES.

6.4.1 Tank Lid Preparation

3. Open the door of the equipment;
4. Remove the back panel or water tank access door;
5. Locate the water tank and remove the twist-tie securing the float of the water tank;
6. Remove the silicone tubing on the heating element;
7. Connect the white wire to the prong on the heating element;
8. Replace the top lid and close door.

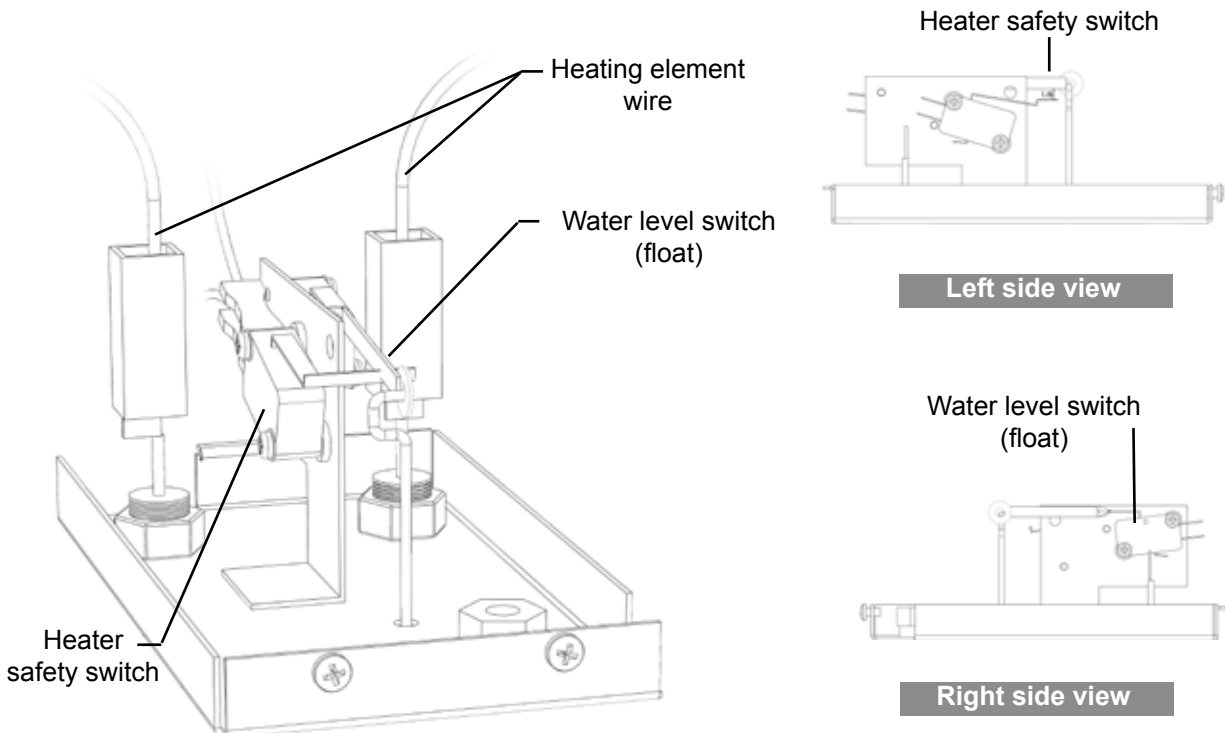

6.4.2 Adjusting the Tank Overflow Float

It is important to verify that the float is positioned appropriately in the overflow cup since it can move around in transportation. If this float is not in place the switch will not be activated and the unit will automatically shut down sensing an overflow situation.

It is important to verify that the overflow cup is in place with the highest side in the front and secured with the tape. If you need to remove this cup, please make sure that you replace it with the highest section facing the front and the overflow tube in the cup. This will ensure that the float will "float" and will activate the overflow switch if there is a problem.

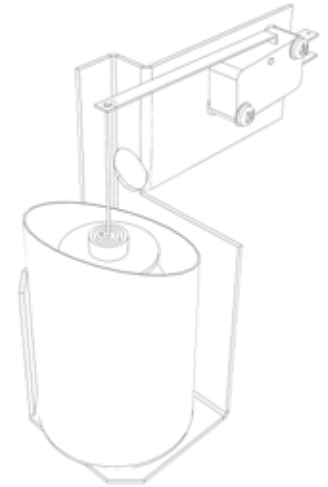

6.5 3 Beans canister installation

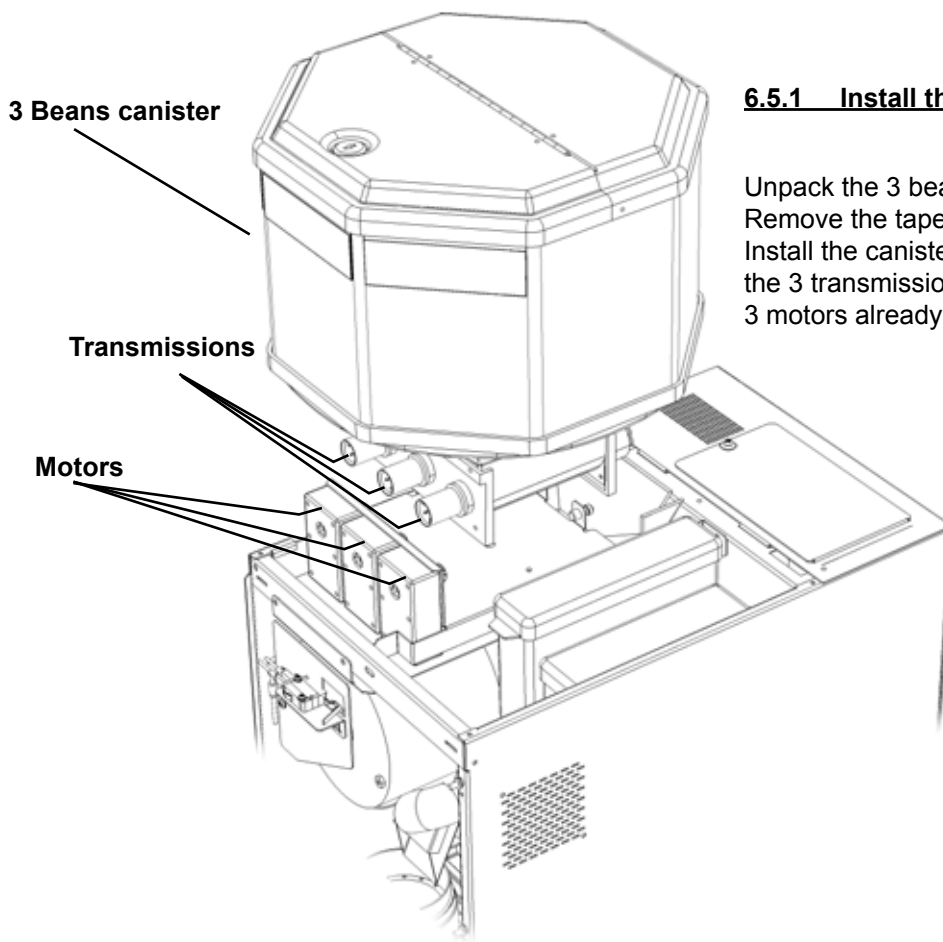

6.5.1 Install the 3 Beans Canister

Unpack the 3 beans canister. Remove the tape from transmission. Install the canister on the shelf by aligning the 3 transmissions of the canister with the 3 motors already fixed on the shelf.



Caution! Flavored beans could contain ethyl alcohol that could affect beans canister's longevity. Cafection do not recommend using flavored beans.

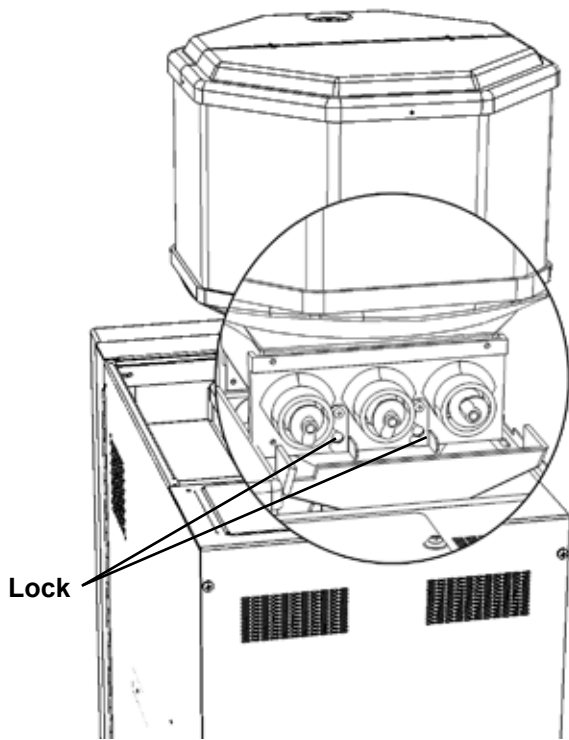

6.5.2 Lock the 3 Bean canister

Pivot the 2 locks vertically, so they clip on the metal pins.

6.5.3 Install the Plastic Top fitting part

Place the piece on the back of the 3 beans canister with the 6-32 screw already in place.

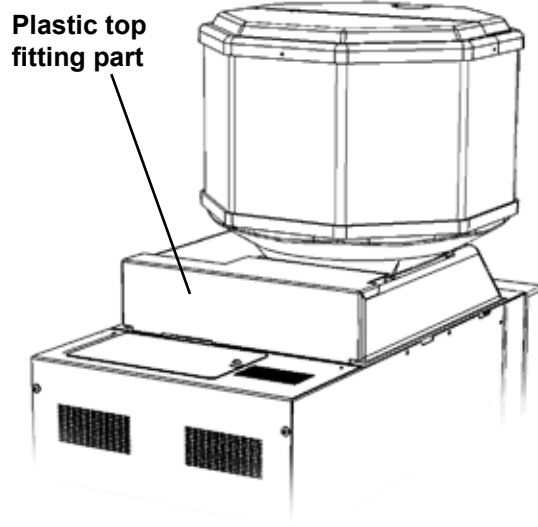
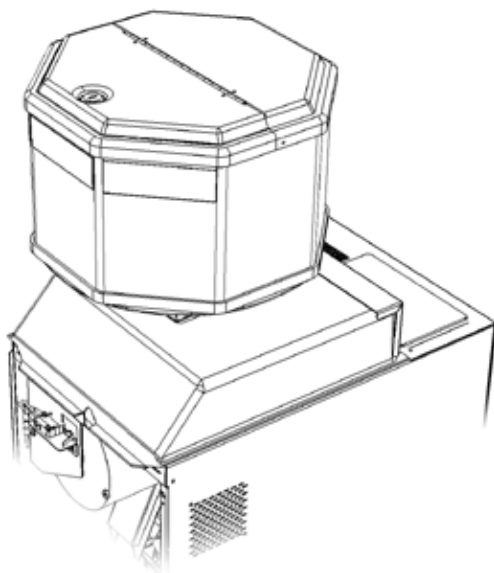

6.5.4 Install the Plastic Top

Simply place the plastic top on the top of the machine as illustrated.

6.6 Water Line Connection



This equipment must be installed in compliance with applicable Federal, State and/or Municipal plumbing codes having jurisdiction.

Make sure that the equipment is unplugged before proceeding with the water supply installation. Also verify that the incoming water pressure is greater than 20 psi and no more than 80 psi.

1. Prior to installing the unit, flush out the water line by running approximately 1 gal. of water into a pail. This will ensure no sediment from a new installation can get in the unit;
2. The incoming water supply should have a shut-off valve connected in-line. Water supply should be a plastic 1/4" or 3/8" O.D. dedicated line branched off a larger supply line;
3. Make sure your water source is turned off. Secure the inlet fitting firmly onto the inlet valve. Do not overtighten;
4. Make sure the equipment is unplugged. Connect the water line to the quick connect inlet fitting;
5. Turn the water valve on, sending water to the brewer. If there are any leaks, tighten connections to stop leakage.



This procedure does not take into consideration the installation of a water filtration system. Please refer to the water filter manufacturer installation instructions and incorporate them into the above.

Water line connection

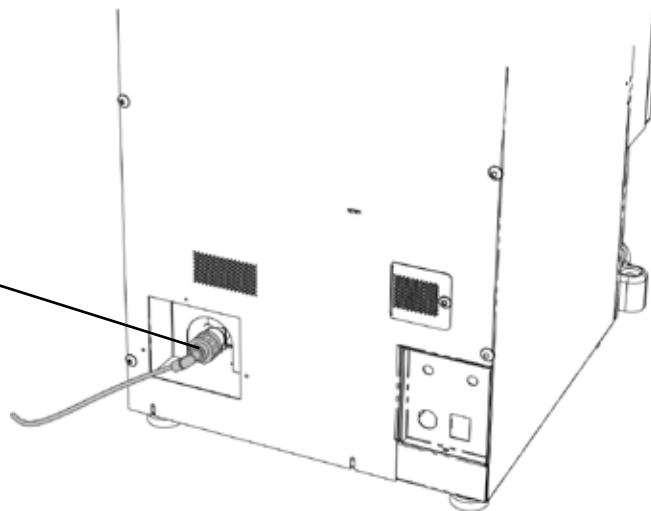

6.7 Electrical Connection



This equipment must be installed in compliance with applicable Federal, State and/or Local electrical codes having jurisdiction.

Make sure:

- The equipment is OFF before plugging it in,
 - The equipment has its own electrical outlet and
 - An extension cord is not used.
-
1. Make sure that the power switch in the back of the unit is in the OFF position before plugging in the unit;
 2. Locate the unit's 6 foot power cord and plug it into its own grounded electrical outlet;
 3. Reach to the back of the brewer and toggle the power switch to the On position. The front lights will go on, and water will automatically enter the brewer. The tank will fill in 2-3 minutes from the moment the brewer is turned on;
 4. Once the tank is full, it will take 15-20 minutes to heat the water to brewing temperature. ;
 5. Once the brewing equipment is ready, the LCD will indicate "Hi! Make Your Choice".

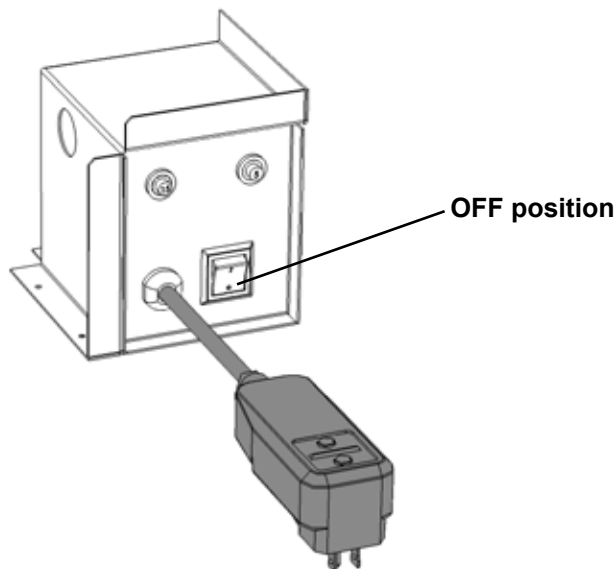

The main power switch turns the equipment off and on. This switch should be turned OFF when servicing any (AC line voltage) electrical components on the equipment.

6.8 Water Temperature

This equipment has a coffee brewing setpoint of 200 F water temperature to offer a consistent beverage quality for the users. There is a +/- 2 degree F tolerance.

This is an average and is not what you would get from a manual temperature measure. The actual water temperature fluctuates since cold water enters the tank after every beverage delivery and time is required to heat the incoming water up to the setpoint.

You can also take the water's brewing temperature manually by ordering a cup of hot water and measuring its temperature with a thermometer. There may be a slight difference from the tank reading. This is normal.

If you are experiencing large temperature differences, verify that your tank is clean and not obstructed by mineral deposits and scale.

Unit safety measures

In the event of a temperature probe failure, the tank may start to boil. This will cause it to overflow into the "Overflow Cup" and will automatically shut off the unit.

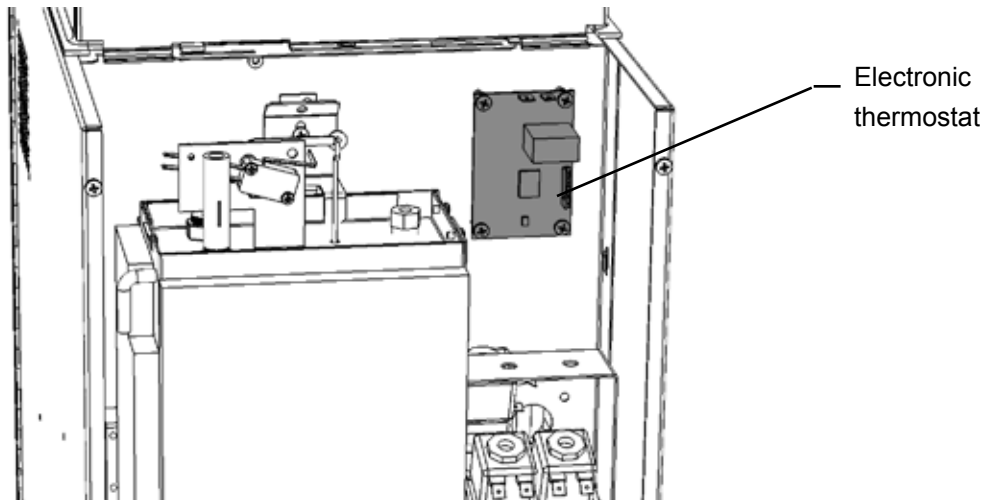

6.9 Loading Products

1. Unlock the main door
2. Remove the plastic top
3. Remove the cap of the canister
4. **Do not overfill the canister**

For the 3 beans canister:

Unlock the cover of the canister and open the plastic top cap.
Do not overfill the canister.

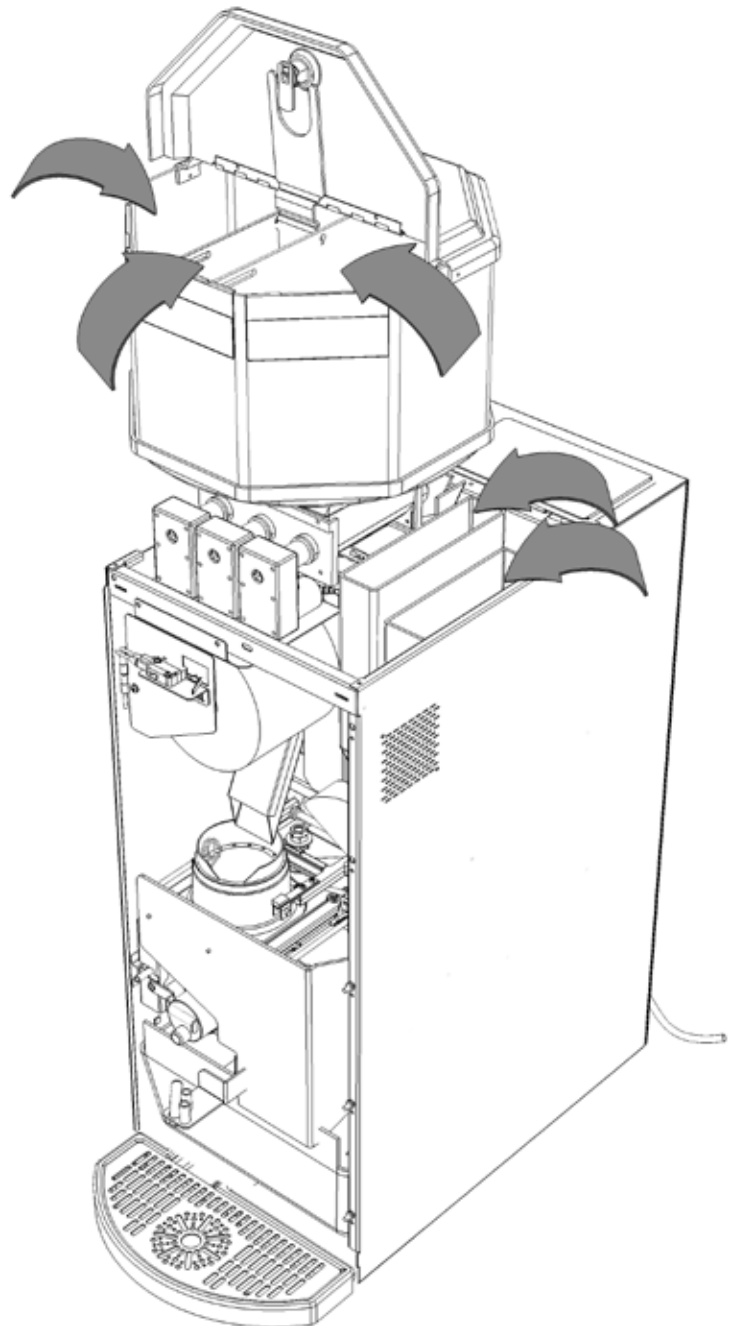

6.10 Chute System Installation

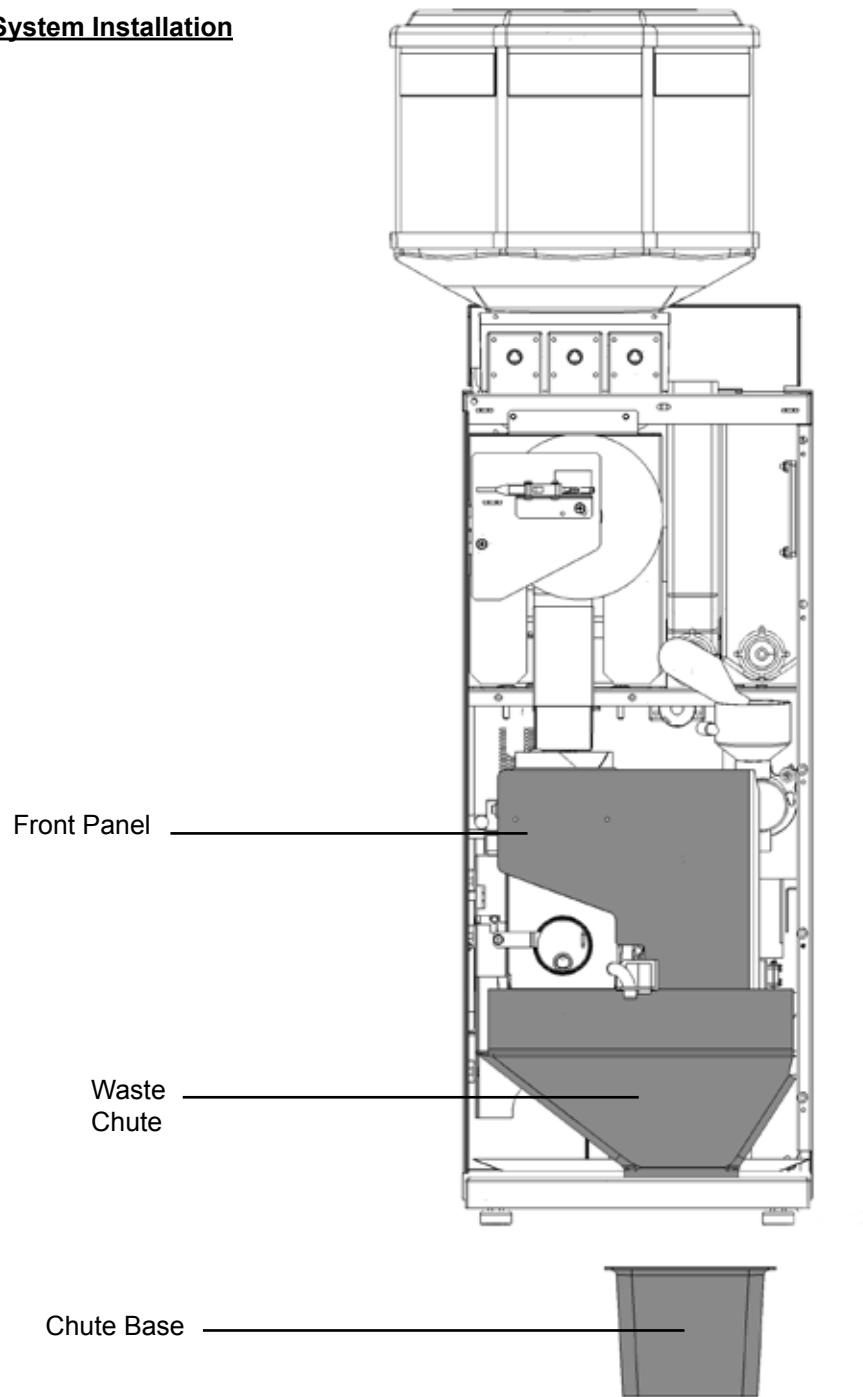

1. Open the door of the equipment;
2. Insert the chute base through the chute hole of the cabinet;
3. Insert the large waste chute into the chute base;
4. Install the front panel onto the chute by aligning the prongs to the left of the catch and clip onto the left side of the brewer assembly.

6.11 Filter Paper Installation

1. Make sure the unit is ON;
2. Place the roll on the paper support bracket so that it dispenses on the left hand side; (See the diagram inside the brewer)
3. Toggle the brewer paper switch to ON (SW4 on the main board, see page 16), the brew chamber will rise;
Note: the brew chamber will not rise if the switch does not sense the filter paper
4. Pass it under the left guide bracket of the brew group, under the brew chamber and under the wheel guides by gently lifting them by the yoke;
5. Pull on the paper and route it through the cabinet chute hole and into the waste bin;
6. Make sure that it is feeding straight. Verify that it stays within the first guide. **Improperly placed filter paper will cause a vacuum leak and may cause grounds to spill off into the machine.**
7. Toggle the brewer paper switch back to the OFF position (SW4 on the main board);
8. The filter paper will advance while the brewer assembly cycles and the brew chamber comes down on the paper, ready for the next cup.

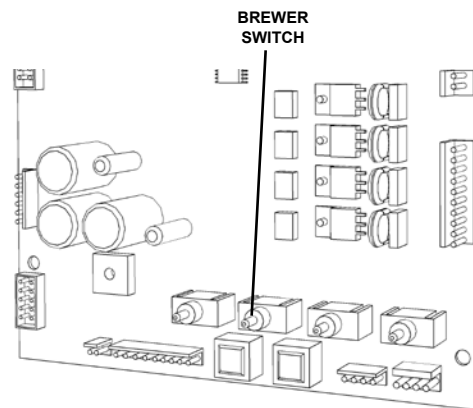
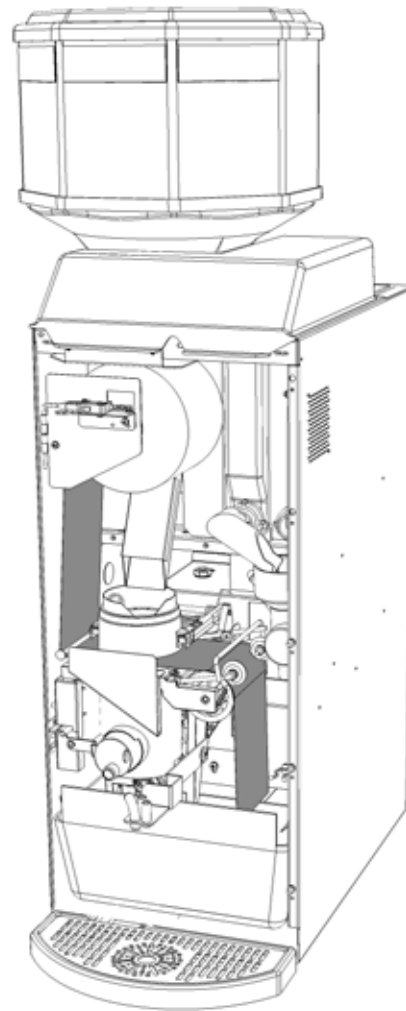

6.12 Installation Testing

It is important to have the unit perform several cycles before completing the installation by ordering each product selection twice to insure that the machine is operating as per the specifications laid out in this manual. During this process, review the check list as a reminder.

You need to be sure that each machine is clean, safe and functioning when you leave it.

	<u>What to check</u>	<u>Remedy, if it is not</u>
✓	Inlet valve is free from leaks	Verify that it is secure and not overtightened
✓	Brew chamber is empty of coffee	Verify that the unit is leveled
✓	Filter paper feeds without resistance and goes straight into the waste bin	Verify that the chute is properly installed Repeat the installation procedure
✓	Soluble mixing bowl is free of leaks	Verify that it is on straight and tube is secure
✓	Water temperature is acceptable	See water temperature
✓	Products are loaded	Load the product
✓	Brewer and area are clean and tidy	Please tidy up
✓	Free vend switch is in the right position	Toggle on or off
✓	Programming is complete	Refer to programming section in this manual

7 SERVICE SOFTWARE

The software allows you to control the machine parameters and retrieve user data from the equipment.

To access the machine parameters:

1. Unlock and open the door of the equipment
2. Press the black SET UP button located on the lower section of the main board (#SW2)

The LCD will indicate:

Setup mode
Press START to exit

To access the user data:

1. Unlock and open the door of the equipment
2. Press the white COUNTER button located on the lower section of the main board (#SW1)

The LCD will indicate:

Display TOTAL
Press START to exit

Machine Parameters Menu

Café Latté: - / No
 Mokaccino: + / Yes
 Hot Water: Move window
 Start: Move character
 / Exit and save



The START button is also used to confirm a change in a configuration, if it is not pushed after a change, the modification will not be kept in memory.

7.1 Configuration:

Open the main door and press the black SETUP (# SW2) button on the main board. Hit the *strenght* button on the selection membrane and the configuration menu will appear. Scroll through the options using the hot water button and keep in mind that the Café Latté button equals no and the Mokaccino button equals yes. Follow the menu from left to right.

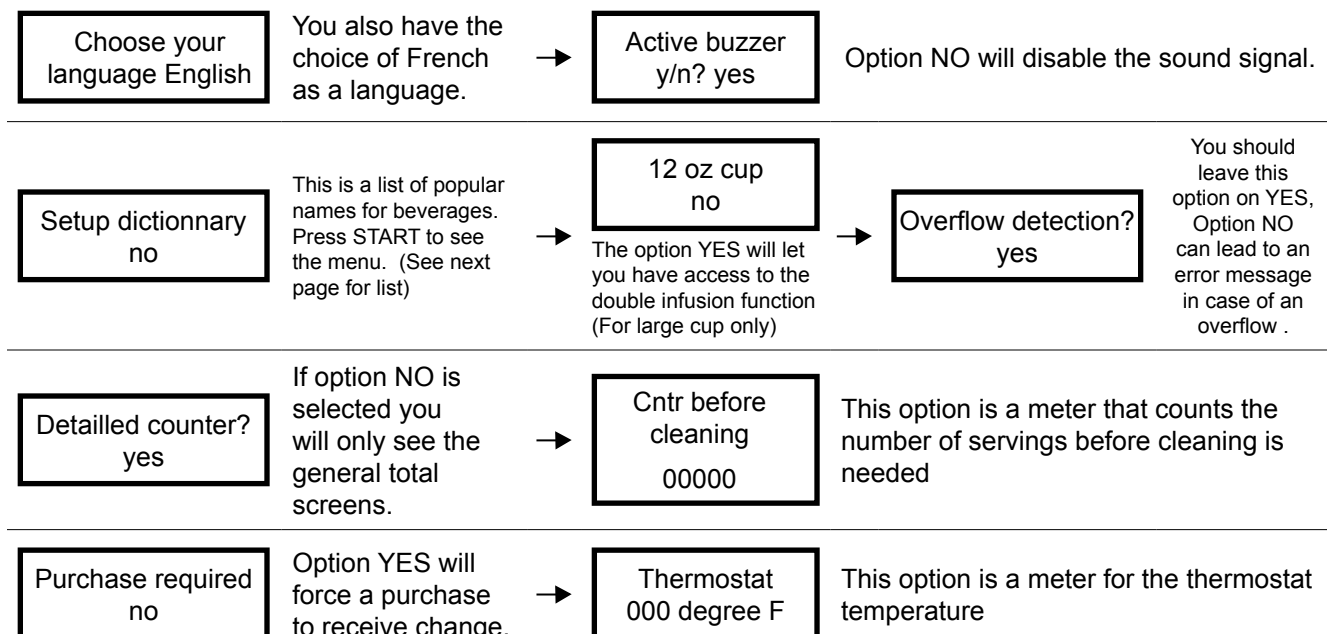

7.1.1 Dictionary

1. Coffee #1
2. Coffee #2
3. Coffee #3
4. Chocolate

Press the button of the selection you wish to detail with a word from the dictionary.

7.2 Product Configuration

The shaded selections should not be changed without calling the manufacturer.

Selection Coffee #1 (from left to right)

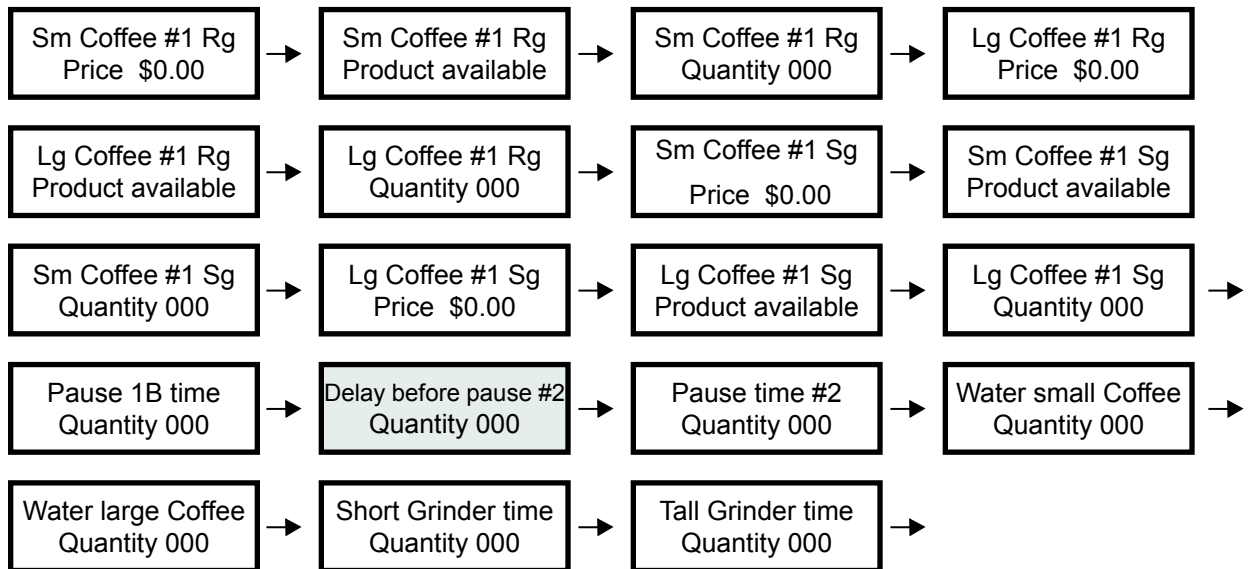

Selection Coffee #2 (from left to right)

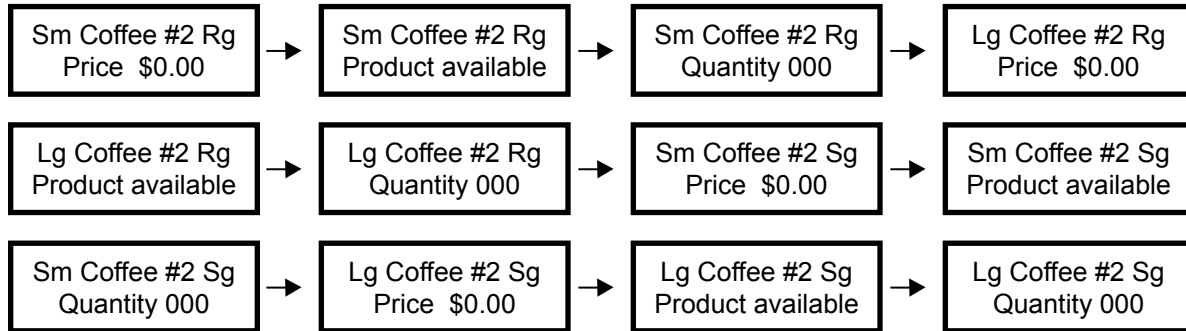

Selection Coffee #3 (from left to right)

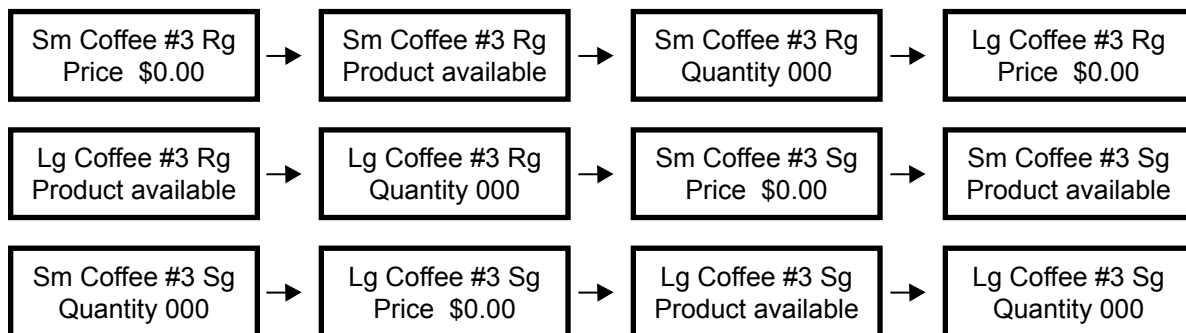

Selection Americano (from left to right)

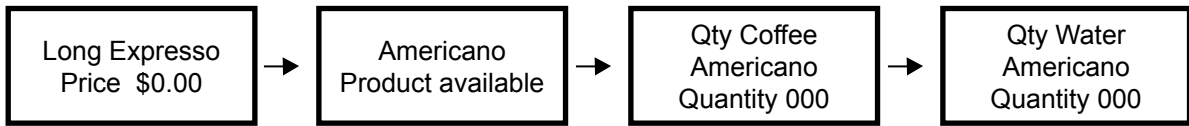

Selection Chocolate (from left to right)

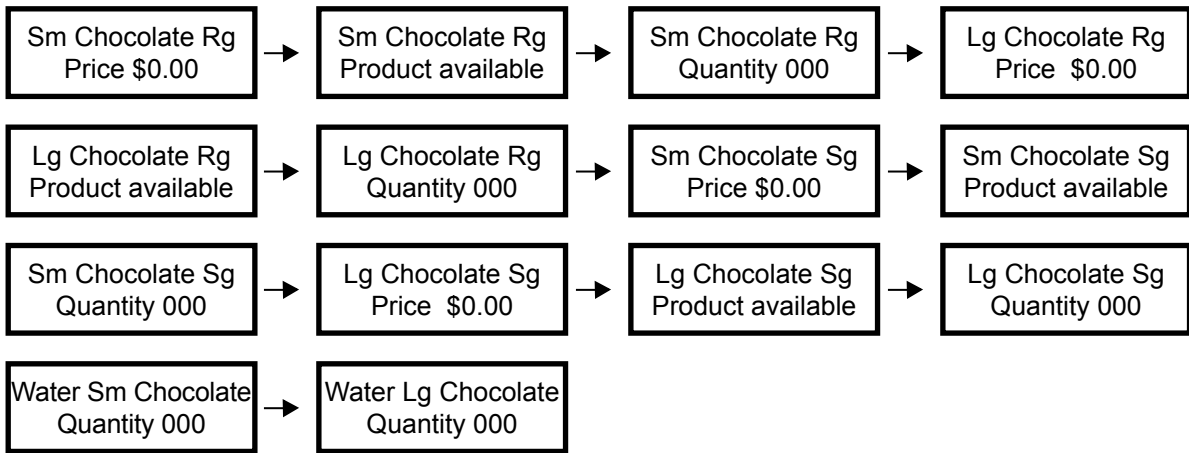

Selection Mokaccino (from left to right)



Selection Café Latté (from left to right)

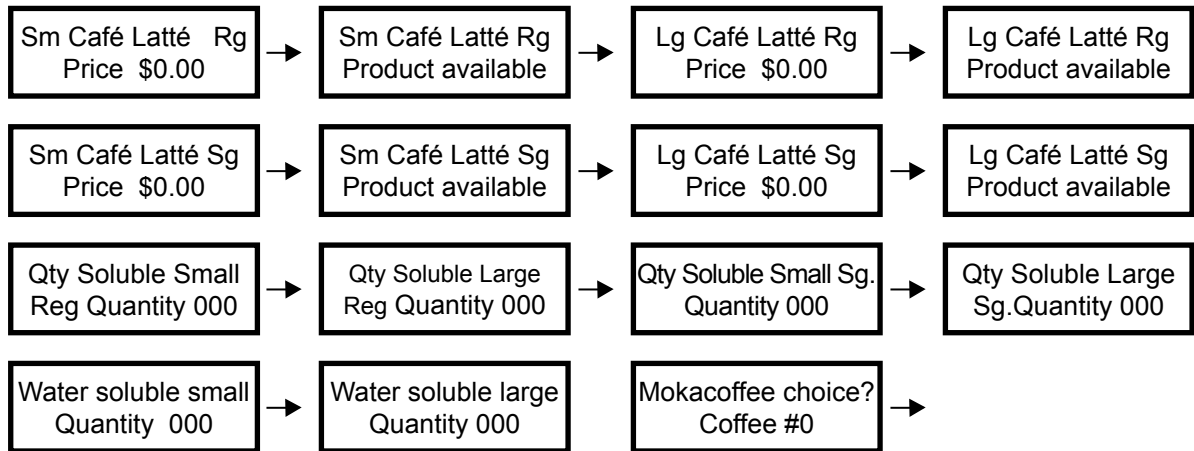

** Coffee part is preset by Mokaccino setting

Selection Hot Water(from left to right)

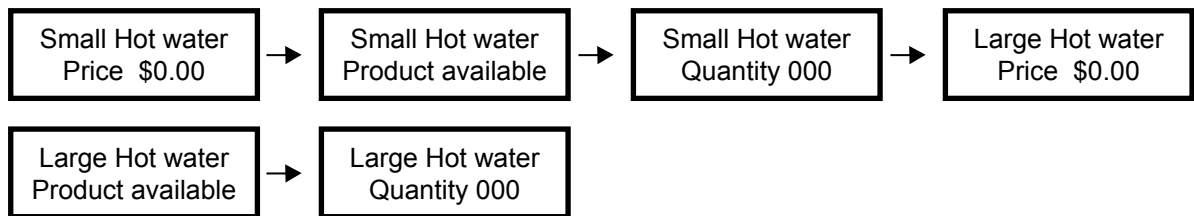

7.3 Counter Display

To see the counter display, unlock and open the front door and press the white COUNTER button. The screen should show this:

Display TOTAL
Press START to exit

To scroll through this menu, use the START button. Below are the screens that will be shown:

Selection Coffee #1 (from left to right)

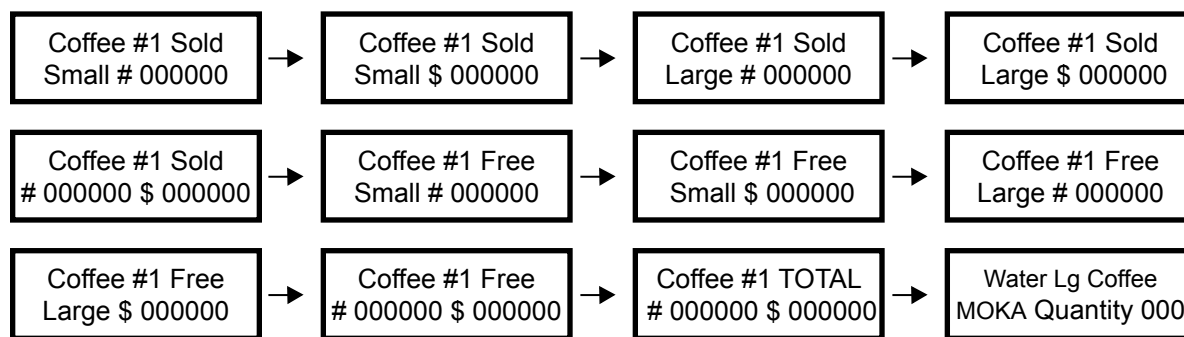

**This menu is exactly the same for Coffee #2, Coffee #3, Americano, Chocolate, Café Latté, Mokaccino and Hot Water, only the name of the selection changes.

To see the total quantity and amount counter, unlock and open the front door of your unit, press on the white button and press the strenght. To scroll through the menu use the hot water button counter and press START to exit.

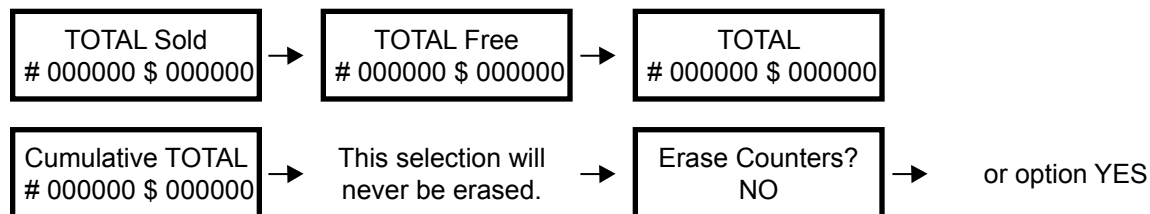

7.4 Counter Tracking Sheet

Use this sheet to record the data of the unit.

** sm = Small, lg = Large

Beverage type	Counter data				
	Qty	Sold \$	Free #	Total#	Total \$
Coffee #1 - sm					
Coffee #1 - lg					
Coffee #2 - sm					
Coffee #2 -lg					
Coffee #3 - sm					
Coffee #3 - lg					
Americano					
Chocolate - sm					
Chocolate - lg					
Mokaccino -sm					
Mokaccino -lg					
Café latté - sm					
Café latté - lg					
Hot water - sm					
Hot water - lg					
GRAND TOTAL					

Location: _____ S/N#: _____

Customer signature: _____ Date: _____

7.5 Setting Tracking Sheet

Use this sheet to record the data of the unit.

Beverage type	Setting data							
	Small regular		Large regular		Small strong		Large strong	
	Qty	Price	Qty	Price	Qty	Price	Qty	Price
Coffee #1								
Water coffee								
Coffee #2								
Coffee #3								
Americano								
Water americano								
Chocolate								
Water chocolate								
Mokaccino								
Coffee mokaccino								
Watercoffee moka								
Choco mokaccino								
Water choco moka								
Café latté								
Soluble café latté								
Water café latté								
Hot water								

Location: _____ S/N#: _____
 Customer signature: _____ Date: _____

7.6 Programming chart

		7	8	9	10	11	12	13	**DOUBLE BREW			
CUP SIZE		7	8	9	10	11	12	13	14	16	18	20
LIQUID OUNCE		5	6	7	8	9	10	11	12	14	16	18
Coffee #1, 2 & 3 <small>*Coffee in grams</small>	<i>Regular Coffee (1,5 gr/liquid oz)</i>	7,5	9	10,5	12	13,5	15	16,5	18	21	24	27
	PROGRAMMING VALUE	35	42	49	56	63	70	77	42	49	56	63
	<i>Strong Coffee (1,7 gr/liquid oz)</i>	8,5	10,2	11,9	13,6	15,3	17	18,7	20,4	23,8	27,2	30,6
	PROGRAMMING VALUE	40	48	56	64	71	79	87	48	56	64	71
Configurable <small>Pause times</small>	Pause # 1	40	40	40	40	40	40	40	40	40	40	40
	Delay before Pause #2	118	118	118	118	118	118	118	118	118	118	118
	Pause # 2	150	150	150	150	150	170	170	150	150	150	150
	PROGRAMMING VALUE											
	Grinder time	120	120	120	120	170	170	170	120	120	120	120
	PROGRAMMING VALUE											
Coffee liquid <small>Liquid OZ</small>	<i>QUANTITY OF LIQUID</i>	5	6	7	8	9	10	11	12	14	16	18
	PROGRAMMING VALUE	86	102	120	138	156	174	192	102	120	138	156
Hot Chocolate <small>*Soluble in grams</small>	<i>Regular chocolate (2,8 gr/liquid oz)</i>	14	16,8	19,6	22,4	25,2	28	30,8	33,6	39,2		
	PROGRAMMING VALUE	38	46	53	60	68	76	84	91	106		
	<i>Strong chocolate (3,2 gr/liquid oz)</i>	16	19,2	22,4	25,6	28,8	32	35,2	38,4	44,8		
	PROGRAMMING VALUE	44	52	61	69	78	87	96	105	123		
Chocolate <small>Liquid Liquid</small>	<i>QUANTITY OF LIQUID</i>	5	6	7	8	9	10	11	12	14		
	PROGRAMMING VALUE	52	74	96	118	140	161	183	204	248		
Americano	Americano Coffee			75								
	Americano Water			86								
Mokaccino	Regular Moka Coffee	46	56	65	74	84	93	102	112	131		
	Moka Coffee Water	30	37	45	53	62	70	78	86	102		
	Regular Choco Moka											
	Strong Choco Moka											
	Choco Moka Water	15	28	40	52	65	77	90	102	127		
Vanilla Coffee	Regular Vanilla Coffee, Coffee	67	76	64	73	83	92	101	111	130		
	Strong Vanilla Coffee, Coffee	53	63	74	84	95	105	115	125	145		
	Vanilla Coffee Water	19	27	35	43	52	60	69	77	94		
Hot water		72	90	108	126	144	162	180	198	234		

FACTORY SETTING	DOUBLE BREW
-----------------	-------------

**Coffee and soluble grams quantities are provided as suggested information only ; weight may vary depending on the kind of products (roast, grind or density for solubles).

**Double Brew requires an extended base PEACC14 this will permit bigger cups/mugs **

8 CLEANING AND SANITIZING

8.1 Cleaning and Sanitizing Instructions

It is important to clean and sanitize this equipment on a regular basis in order to maintain the highest beverage quality. These regulations require that all parts in contact with food be cleaned and sanitized regularly and that hands be cleaned before handling these parts or other commodities such as cups and stirrers.

Cleaning and sanitizing should be done in separate steps as prescribed by health regulations and good industry practice.

Cleaning: Cleaning means “Making free of visible soil, stains or impurities”. This also means removing food soils, oil or mineral deposits that could alter the beverage taste or appearance and therefore, its quality.

Sanitizing: Sanitizing means application of measures designed to protect public health. This is done by removing bacteria remaining on the surface after it has been cleaned.

There are two sanitation methods:

1. Chemically, the part can be treated with a bactericidal compound to remove bacteria;
2. With water of at least 212 F, the bacteria can be killed if the temperature of the part is raised high enough.

Always unplug the unit before using water to clean the machine. DO NOT spray water on electrical parts.

For the sanitation process to work effectively, the part must be cleaned and free of all visible food soil, completely rinsed and preferably air dried. Wiping with towels or cloths can recontaminate cleaned food-contact surfaces. Therefore, we recommend to air dry sanitized food - contact surfaces and not wipe dry.

FREQUENCY:

There are two important variables that need to be considered when evaluating cleaning and sanitizing frequencies:

- Product consumption
- Water quality

Since the expected customer usage may vary for one location to another, the cleaning and maintenance is recommended upon the given time lines or cycle counts, whichever ever comes first. Note that these are intended as a guideline to ensure a part does not go without cleaning. We recommend you verify each part listed in this section upon each visit and that they be cleaned as needed.

8.2 Recommended Cleaning Tools

In order to perform the following cleaning procedure effectively, we recommend that you have at least the following tools:

- Pail or bucket
- Small tube brush suitable for food-contact surfaces
- Medium size long and flexible brush, suitable for food-contact surfaces
- Medium brush for coffee grounds, suitable for food-contact surfaces
- Disposable towels, wet-strength and lint-free
- Mild nonabrasive detergent for exterior cleaning
- Urn cleaner packets for coffee parts
- Spare parts if extensive cleaning is to be done at the shop
- Garbage bags for the waste bin

8.3 Cleaning and Sanitizing Schedule

The cleaning schedule and instructions outlined in this manual must be followed to honor the warranty and ensure consistent product quality and maintain health safety levels.



All parts should be visually inspected upon each visit and cleaned as needed.

Exterior	Daily	Weekly	Monthly	Quarterly	As needed
Waste bin	Inspect				Clean
Canisters (3 beans canister)		Inspect			Clean
Drip tray	Clean				
Unit + Stand	Clean				

Interior / Food Contact Parts	Daily	Weekly	Monthly	Quarterly	As needed
Brewer assembly	Sanitize	Clean	Treatment		
Brew chamber		Sanitize			Clean
Whipper & mixing bowls		Sanitize			Clean
Fan			Inspect	Clean	
Soluble canister			Sanitize		
3 Beans canister			Clean		
Stainless coffee chute			Clean		
3 Beans canister plastic chute			Clean		
Rinse cycle	Process				

These recommendations are based on 1,000 cycles per month, medium blend coffee and superior water quality levels. The above recommendations will need to be adjusted if the beverage volume, coffee blends used and water quality differ.

8.4 Overall Cleaning

It is important to keep the brewer and its surroundings clean and tidy. Inspect your brewer both inside and out upon each visit and clean where needed. Please make sure that the unit is clean, safe and functioning before you leave.

8.5 Exterior Cleaning

Frequency: Daily

To minimize scratching and preserve appearance, we recommend using a clean damp sponge or soft cloth lightly treated with a nonabrasive detergent for cleaning the exterior of the unit and the base cabinet. After removing all food soils, thoroughly dry with a clean, soft cloth.

Non food-contact parts to be verified and wiped clean

- | | | | |
|-------------------------------------|---------------|-------------------------------------|------------------|
| <input checked="" type="checkbox"/> | Metal Top Cap | <input checked="" type="checkbox"/> | Stand (optional) |
| <input checked="" type="checkbox"/> | Metal Cabinet | | |
| <input checked="" type="checkbox"/> | Plastic Door | | |

Exterior parts requiring additional cleaning instructions (see below)

- | | |
|-------------------------------------|-----------|
| <input checked="" type="checkbox"/> | Drip Tray |
| <input checked="" type="checkbox"/> | Waste Bin |



Parts for this brewer are **NOT** dishwasher safe!

8.5.1 Cleaning the drip tray

Frequency: Daily or as needed

The drip tray is not hooked up to a drain therefore it should be inspected and emptied periodically.



WARNING, drip tray may be full of hot water.

Use caution and keep it level to avoid spilling. Remove the drip tray by simply lifting gently and pulling it out from underneath the door. Rinse both parts under water and dry thoroughly with a clean dry cloth or towel. Reinstall the drip tray onto the brewer and make sure that it is stable.

8.5.2 Emptying the waste bin

Frequency: Daily or every 200 cycles*

After each coffee cycle, the spent grounds and used filter paper are automatically discarded into the waste bin located in the stand. To prevent the bin from overflowing there is an automatic function which stops the brewer and shows the following message on the LCD screen:

Needs Service
Activate Brewer

The maximum setting = 399

The minimum setting = 0

Setting it to 0 will disable the automatic function and will cause an overflow problem if the bin is full.

The equipment will not dispense beverages until the bin is emptied and the counter is reset. To reset the counter, the brewer switch (#SW4) needs to be activated by being turned on and off. This factory set counter can be adjusted to the waste bin size used. See the machine parameters for more instructions on changing the setting.

How to empty the stand waste bin:

1. Open the stand door located directly below the brewer;
2. Cut the filter paper 4" below the drum with scissors or tear gently; DO NOT YANK ON THE PAPER!
3. Remove the filled plastic bag from the spent grounds bin and replace with a new one;
4. Activate the brewer switch (#SW4) by turning it on and off (right then left).

How to empty the brewer internal waste bin*:

1. Open the brewer door;
2. Take the front panel off;
3. Activate the brewer switch (#SW4) by turning it on (to the right);
4. Cut the filter paper 4" below the drum with scissors or tear gently; DO NOT YANK ON PAPER!
5. Activate the brewer switch (#SW4) by turning it off (to the left);
6. Replace the front panel and close the door.



It is very important not to yank on the filter paper. Doing so may prevent the brewer from functioning properly.

* If you are using the internal waste bin provided with the unit, we recommend to set the counter to 25 cycles.

8.6 Interior Parts Cleaning & Sanitizing

For sanitary reasons, do not use soap or detergent inside the brewer. Use hot water for on-site sanitation or suitable chemical products in the shop. Wiping with towels or cloths can recontaminate sanitized food-contact surfaces. Therefore, we recommend to air dry sanitized food-contact surfaces and not wipe dry. Allow sufficient time for the parts to dry thoroughly before closing the door.



Use a medium size brush dedicated for coffee grounds and a small dust pan to easily brush away coffee grounds and dust inside the brewer before cleaning with water.



Interior Parts to be cleaned

- Canisters
- Coffee brewer
- Coffee funnel
- Fan
- Stainless coffee chute
- 3 Beans hopper plastic chute

8.6.1 Coffee Canisters

Removing canisters for cleaning

Frequency: Monthly or every 1,000 cycles

Coffee Bean Hopper

1. Unscrew and remove the plastic top fitting part behind the top cap;
2. Remove the top cap of the machine;
3. Unlock the 3 bean canister;
4. Remove the 3 bean canister;
5. Clean and sanitize under hot water and air dry completely;
6. Reinstall all parts in the reverse order.
7. Order a coffee to confirm that all parts or switches have been replaced.



Caution! The rinse water is HOT. Be careful not to get any on you while proceeding with the above steps.

8.6.2 Soluble Canisters

Sanitizing the whipping assembly

Frequency: Weekly or every 200 cycles

This will prevent residue from attaching to the sides of the funnel.

Caution! The rinse water is HOT

1. Place a large cup or other suitable container below the dispensing nozzle to catch the HOT rinse water;
2. Toggle the ingredient switch to Off (SW5);
3. Order several beverages for the hot water to flow through the system;
4. Toggle the ingredient switch back to ON;
5. Order a large beverage to confirm that all parts or switches have been replaced.

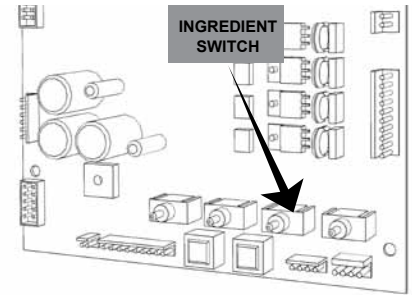

Removing whipping assembly for cleaning

Frequency: Weekly or every 200 cycles

If there is residue, remove the assembly for manual cleaning under hot water:

1. Remove the tube from the base;
2. Lift off the funnel and twist off the whipper chamber, remove propeller, whipper base and clean all parts and gaskets with hot water;
3. Rinse thoroughly under hot water and use tube brush if necessary for tubing area;
4. Air dry completely;
5. Reinstall all parts in the reverse order.
6. Order a large beverage to confirm that all parts or switches have been replaced.

Removing canisters for cleaning

Frequency: Monthly or every 1,000 cycles

To ensure a consistent product quality, we recommend removing and emptying the canisters on a monthly basis. This will ensure that the product does not adhere to the walls of the canister.

1. Unlock the door;
2. Remove the top cap of the machine;
3. Pull the canister up through the top of the brewer to disengage it from the motor and transmission;
4. Clean and sanitize under hot water and air dry completely;
5. Reinstall all parts and reload products in the reverse order.
6. Order a beverage to confirm that all parts or switches have been replaced.

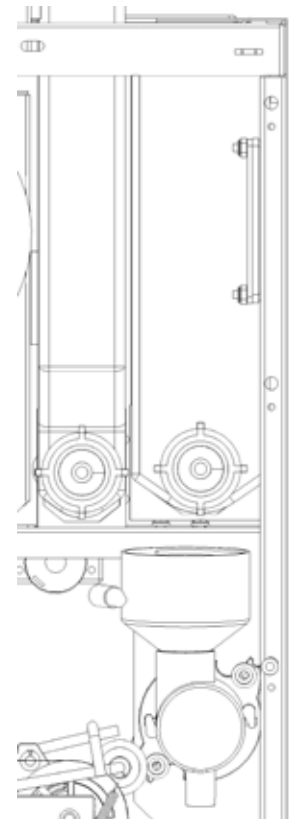

8.6.3 Coffee Brewer

Rinsing the Brew Chamber:

Frequency: Weekly or every 200 cycles

1. Place a large cup or other suitable container below the dispensing nozzle to catch the HOT rinse water;
2. Toggle the ingredient switch to Off (SW5 see main board);
3. Order several coffees for the hot water to flow through the system;
4. Toggle the ingredient switch back ON;
5. Remove the hose and remove the brew chamber's funnel to dislodge coffee residue trapped underneath it and rinse it out;
6. Replace it and align the opening with the brown water hose so that it is against the wall to form a circular water motion around the funnel;
7. Order a large coffee to confirm that all parts have been replaced correctly.

Brewer Funnel Hose Support

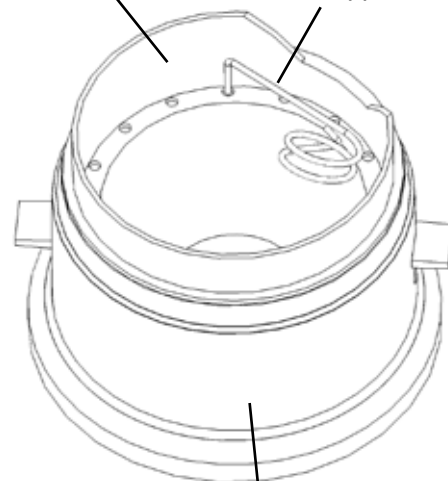

Brew Chamber

Brewer Funnel

Frequency: As needed or weekly

If there are coffee grounds accumulated, remove the assembly for manual cleaning under hot water:

1. Remove the brown water hose;
2. Lift off the funnel and pull out of the brew chamber;
3. Rinse thoroughly under hot water;
4. Air dry completely;
5. Reinstall all parts in the reverse order.
6. Order a large coffee to confirm that all parts have been replaced correctly.

Brewer Assembly Cleaning

Frequency: Monthly or every 1,000 cycles

In order to maintain optimal performance of the brewer assembly, we recommend that it be removed from the unit and cleaned / rinsed with hot water. (see section 10.3 for instructions on removing the brewer)

1. Rinse thoroughly under hot water to remove visible soil;
2. Lift off the funnel and pull out of the brew chamber;
3. Rinse thoroughly under hot water;
4. Air dry completely;
5. Reinstall all parts in the reverse order.
6. Order a large coffee to confirm that all parts have been replaced correctly.



Brewer Assembly Sanitizing Treatment

Frequency: Quarterly or Every 3,000 Cycles

Regular sanitation treatments of the brewer assembly prevents residue from affecting the vacuum in the brewer mechanism and altering taste in the beverage delivered.

1. Place a large cup or other suitable container below the dispensing nozzle to catch the HOT liquid;
2. Pour 1 portion of commercial urn cleaner (brand such as Urnex as directed by manufacturer) into the brew chamber;
3. Toggle the ingredient switch to OFF (SW6 on the main board);
4. Select a small regular coffee on the membrane keypad and hit start;
5. Once the brew chamber is filled with water, turn the brewer OFF via the main switch at the back and wait for 5 minutes;
6. After 5 minutes, turn the brewer back ON to complete the brew cycle;
7. To rinse, make at least 5 brewing cycles of coffee with the ingredients set to OFF;
8. Toggle the ingredients switch (SW6) back ON;
9. Make 2 more coffee selections to complete the rinsing cycle of the brewer.

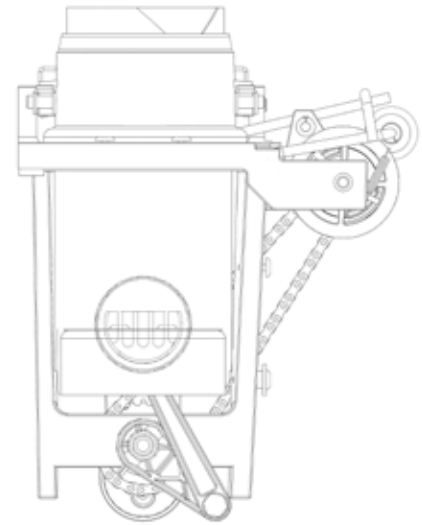

8.6.4 Fan

Frequency: Quarterly or as needed

Visually inspect the fan located directly to the right. If it requires cleaning:

1. Turn off the unit and unplug it to stop the fan;
2. Remove the guard for access;
3. Wipe clean with a dry disposable towel;
4. Replace parts in the reverse order.
5. Tighten gently

Fan

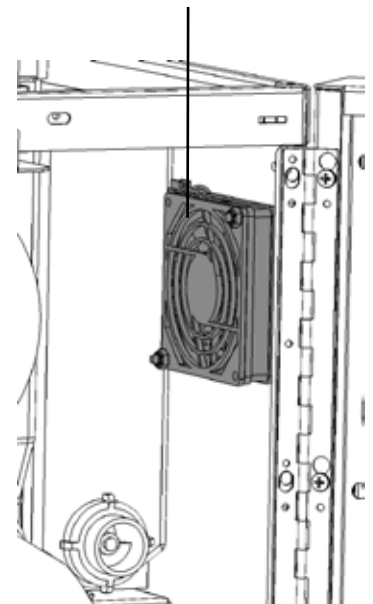

8.6.5 Stainless coffee chute

Frequency: Monthly or every 1,000 cycles

1. Open the door of the machine;
2. Remove the filter paper;
3. Remove the grinder protector;
4. Unplug the 2 connectors from the solenoid;
5. Remove the stainless chute by removing the screw;
6. Clean the stainless chute by rinsing with hot water;
Make sure it is dry before reinstalling.

Repeat the steps in reverse order after cleaning for the reinstallation.

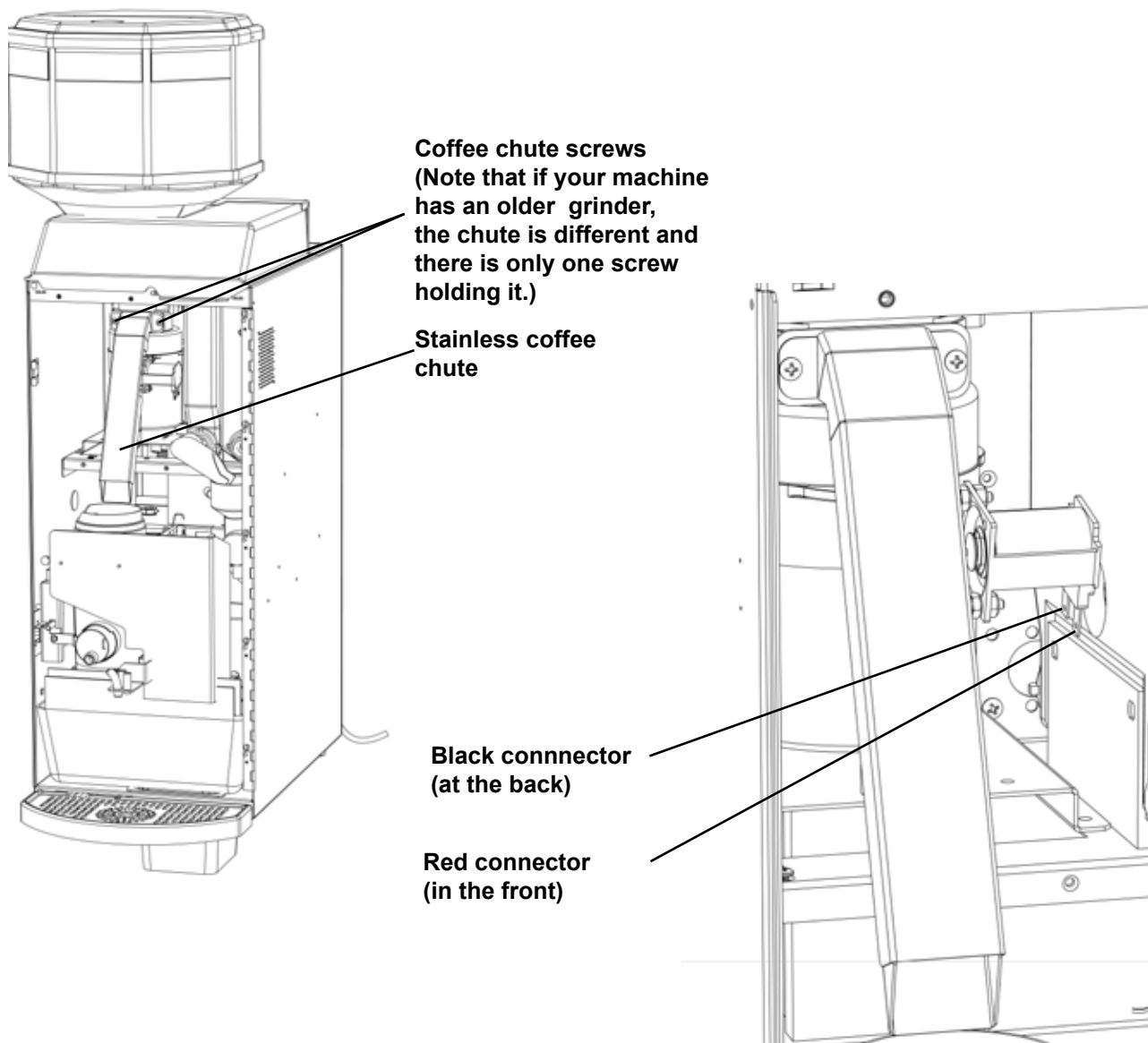

8.6.6 Plastic chute of the 3 bean canister

Frequency: Monthly or every 1,000 cycles

1. Open the door of the machine;
2. Remove the plastic top cap;
3. Unscrew and remove the plastic top fitting part accessing by the rear;
4. Unlock the 3 bean canister;
5. Remove the 3 bean canister;
6. Clean the interior of the plastic chute (accessible by the rear).

Repeat these steps in reverse order when the cleaning is done.

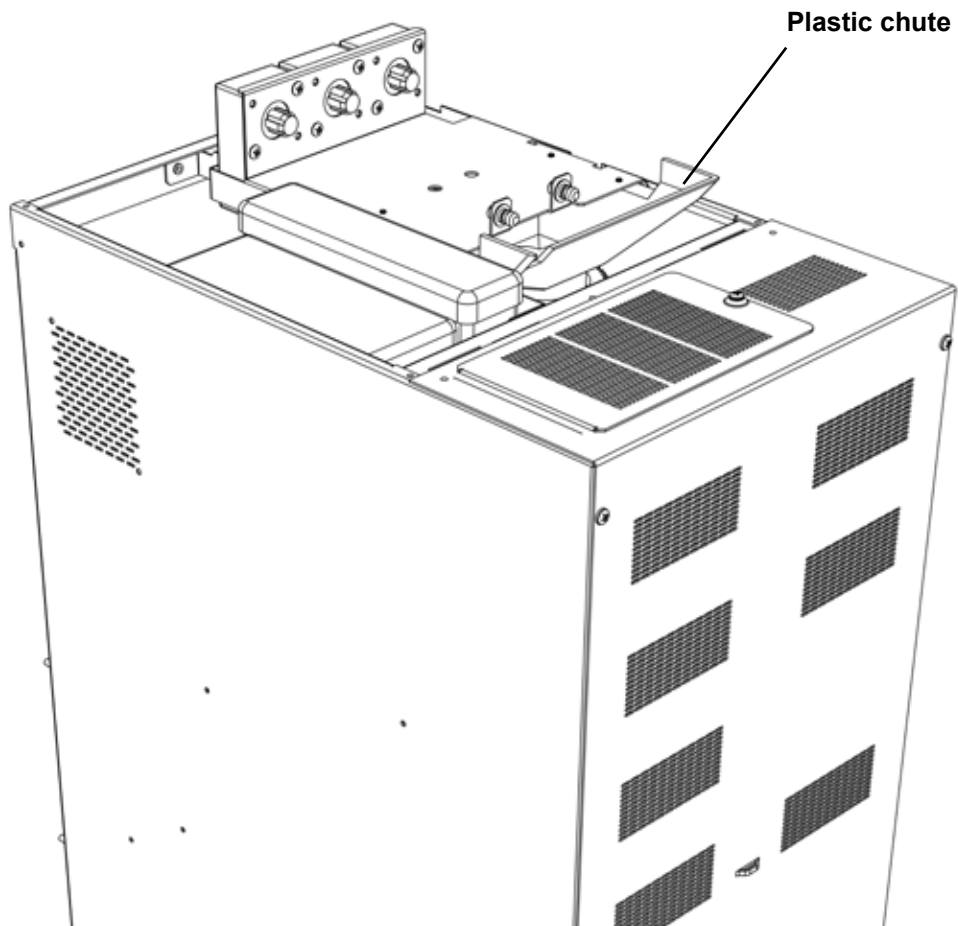

9 PREVENTIVE MAINTENANCE

All major parts of this brewer needs to be maintained as per the schedule to honor the warranty and to prevent it from failing. With adequate maintenance you will extend the life of your unit and deliver a consistent high quality beverage.



The preventive maintenance schedule and instructions below must be followed to honor the warranty.

9.1 Preventive Maintenance (PM) Schedule

All parts should be visually inspected upon each visit and cleaned as needed.

Parts	Monthly	Quarterly	10,000	25,000	60,000	100,000
Brewer	Inspect			Replace		
Outlet Valves	Inspect		PM			
Water Tank		Inspect			PM	

9.2 Brewer Assembly

Preventive Maintenance (PM): Yearly or every 25,000 coffee cycles

The brewer is the heart of the equipment and is responsible for the taste of the beverage. It needs to be replaced or refurbished to maintain the quality of the beverages served. We recommend having your brewer assembly replaced every 25,000 coffee cycles.

Contact 1-800-561-6162 for parts and additional information.

Inspection

The following are signs of the vacuum is not functioning adequately and that your brewer may be due for preventive maintenance:

- if the seal is damaged;
- if air gets into the cylinder and creates bubbles in the coffee;
- if there are coffee grounds in the delivered product;
- if the spent coffee grounds remain wet.

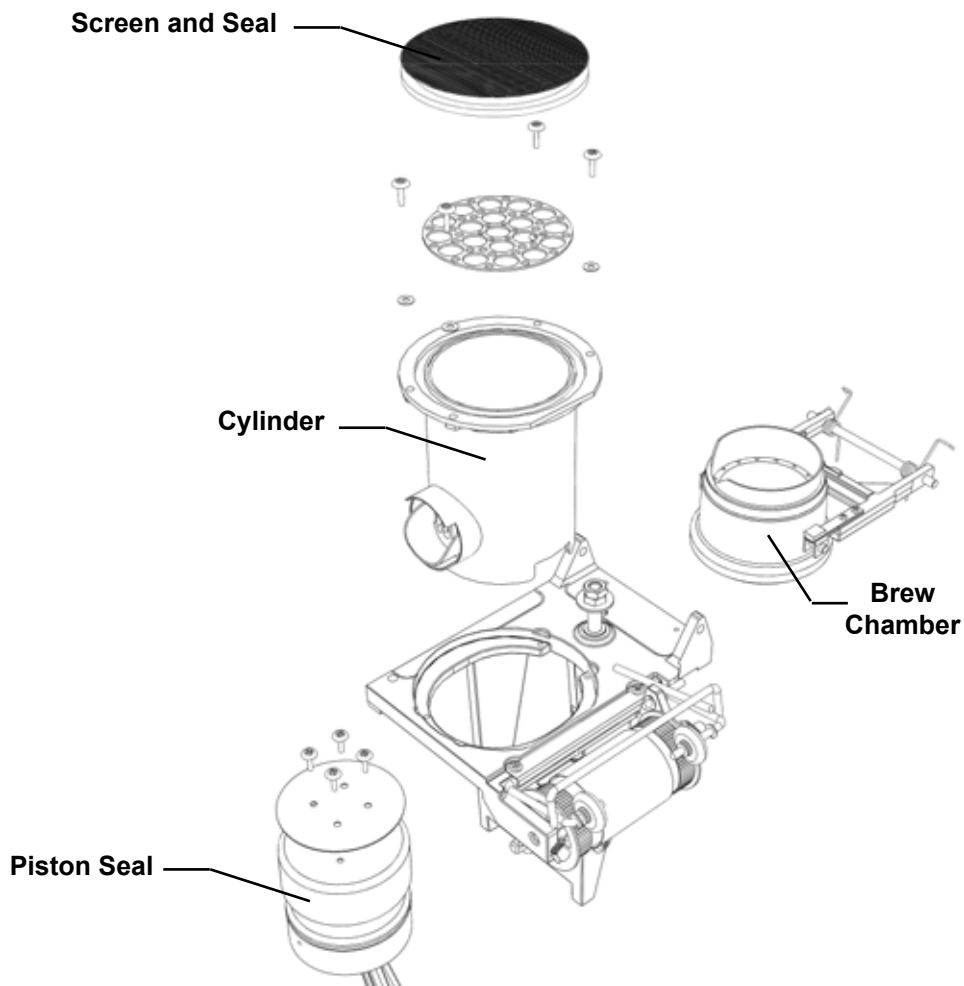

9.3 Water Outlet Valves

Quarterly or every 10,000 cycles

To avoid any problems related to mineral deposits over time, we recommend having the 3 valves swapped, and rebuilt in your shop with the kits included in the spare parts briefcase. Refer to the manufacturer's instructions included with the valve kit.

Leaking valve

- a) Identify the leaking valve, change it and rebuild it
- b) If the leak comes from under the body of the valve or from the tank exit, try simply changing the conical mounting seal.
- c) If the coffee valve leaks via the tubing, water will accumulate in the brew chamber. If it drips all night, the first coffee of the morning may cause the chamber to flood since it contained too much water and may be lukewarm.

Removing and installing the valves

1. Turn off the machine;
2. Unplug the lid (fig.1.1) and the valves (fig. 1.2);
3. Drain the water from the water tank completely (see section 10.1);
4. Remove the tubes;
5. Unscrew the tank guard to remove the tank;
6. Tilt the tank towards you to have access to the valves;
7. Remove the valves;
8. Reinstall by repeating in the reverse order



Caution water is hot!

Unplug these connectors

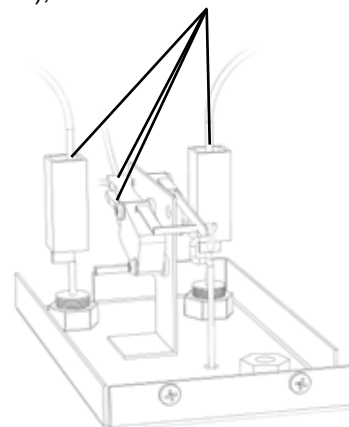

Tank Lid Fig. 1.1

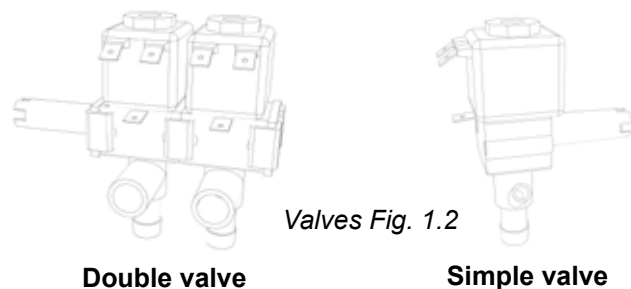
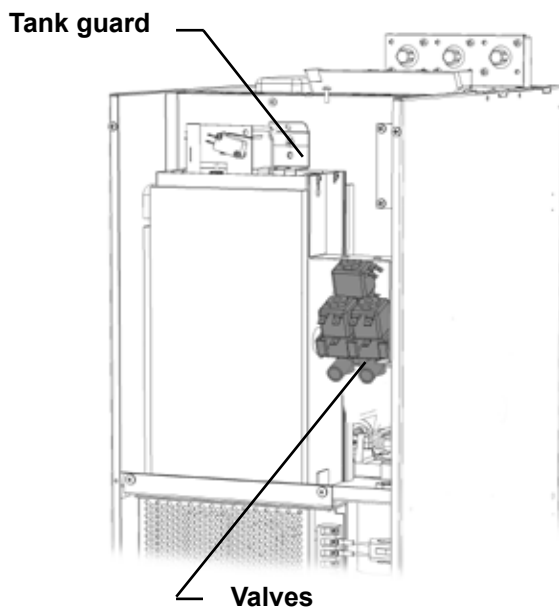

Double valve

Simple valve

Valves Fig. 1.2



If you choose to install a water filtration system, it is recommended that the filter be checked on a monthly basis.

9.4 Hot Water Tank

PM: every 60,000 cycles, quarterly inspection

To avoid any problems related with mineral deposits over time, we recommend having the water tank assembly delimed to remove all scale in the unit. Upon visual inspection, you may wish to replace the element, probe and the water level and heater safety switch.

Use a scale remover product such as Scale Kleen by Everpure.

See the manufacturer instructions for more details.

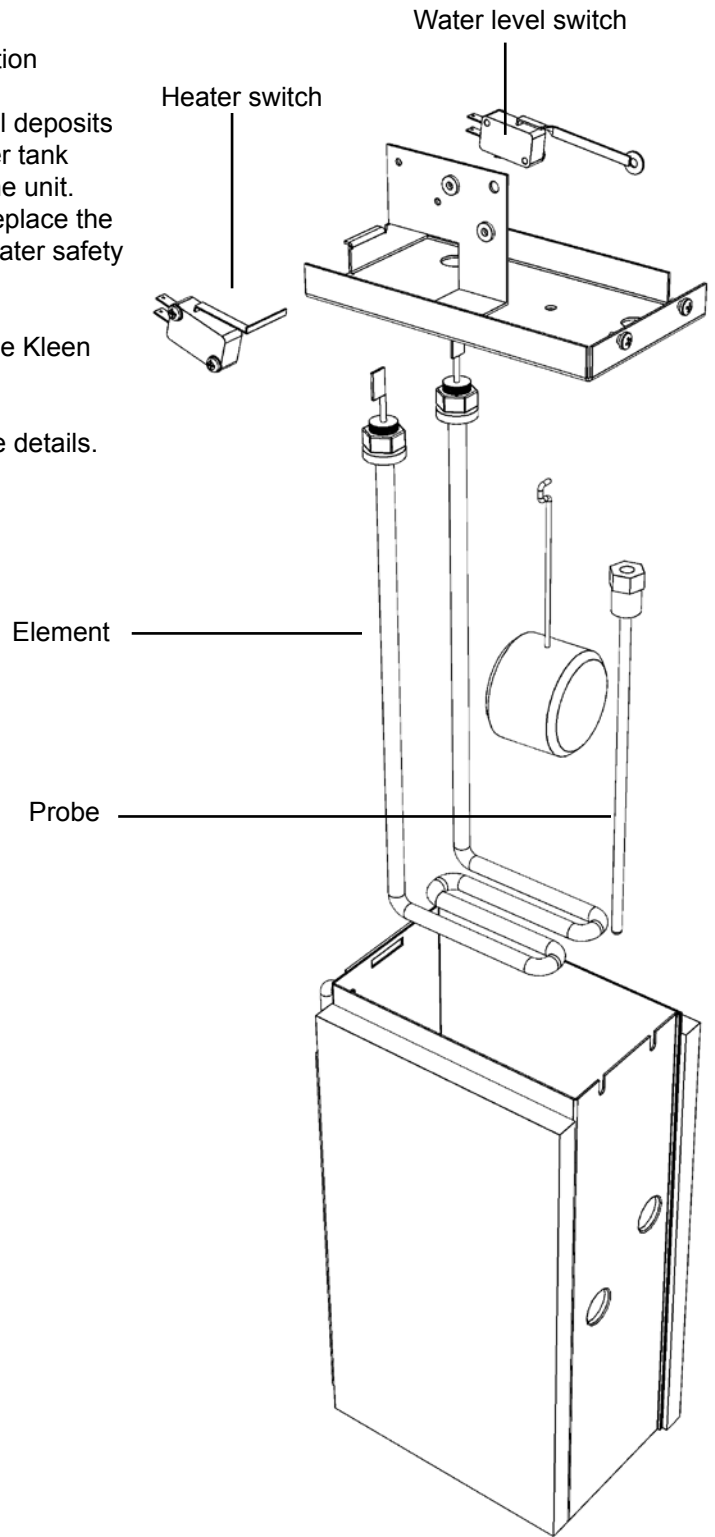

10 SERVICING PARTS

This section is intended to assist you in servicing various parts of the unit.

10.1 Draining the Hot Water Tank

We recommend allowing 3 hours for the hot water to cool prior to emptying the tank. Make sure you have a 0.8 gallon container suitable for holding hot water.

1. Turn off and unplug the brewer;
2. Turn off the main water supply of the machine;
3. Remove the back panel;
4. Locate the drain tube with a red plug;
5. Direct the tube into the pail and remove the red plug. **Warning, water may be hot!;**
6. Drain the water from the water tank completely;
7. Reinstall by repeating these steps in the reverse order.

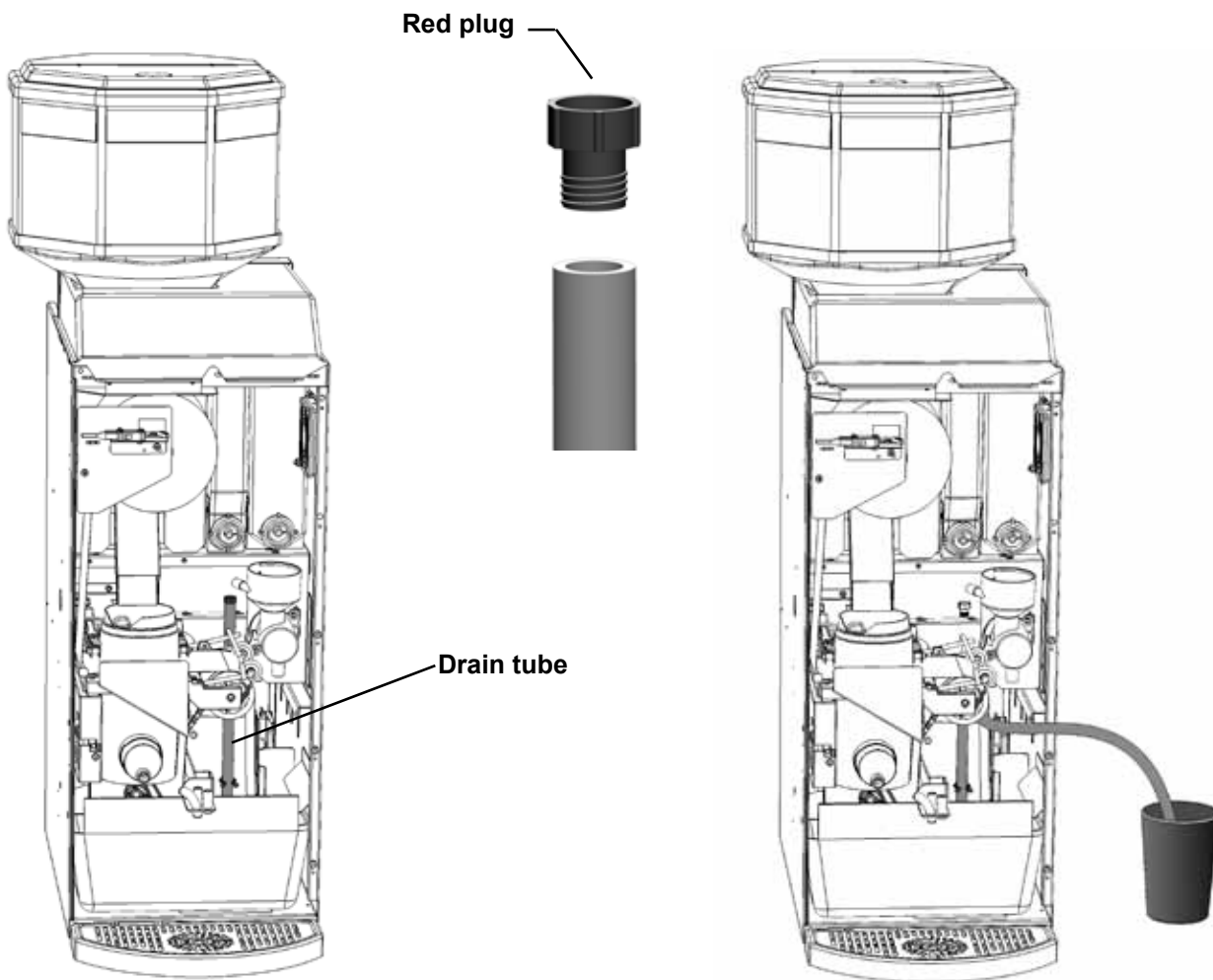

10.2 Shutdown / Storage

If you need to store this brewing equipment for an extended period of time, follow this procedure to avoid any risk of injury or damage to the equipment.

1. Turn the unit off and unplug from the power outlet;
2. Drain the hot water tank (see instructions see section 10.1);
3. Empty the soluble canisters and the 3 bean canister;
4. Clean all parts of the unit before storing (see cleaning instructions see section 8)
5. Disconnect the white wire from the heating element (see installation diagram see section 9.3)
6. Tie down the water level switch's arm with a twist tie to keep the float from pulling down on the switch during transportation. "**Do not overtighten**", this may damage the switch; this is simply to keep the float from bouncing up and down on the switch.

10.2.1 Storing the Brewer Assembly

The brewer assembly is the heart of the equipment and is responsible for the taste of the coffee. It is therefore important that you store it properly when it is not in the unit. Always disengage your brewer clutch by using a pair of pliers and turning the pin located on the back clockwise until the brew chamber lifts up. This will release the pressure on the screen and seal. Your brewer must be on its back or its left side while on a table top. Do not sit the brewer on its right side (wheels and yoke) or straight up as these positions are not sturdy and could cause it to fall.

10.3 Brewer Assembly

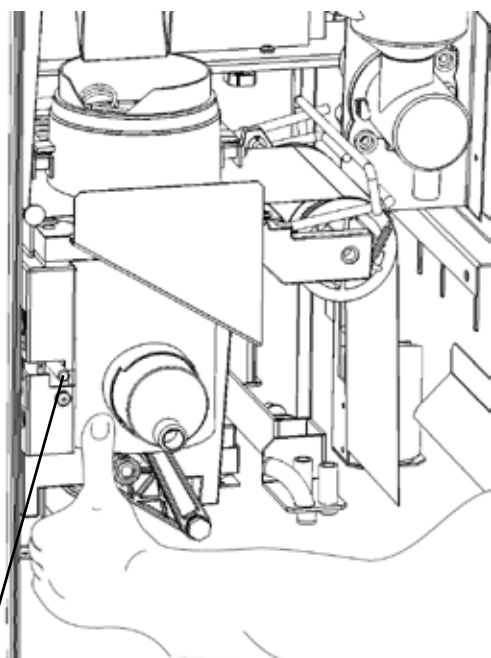

Retaining pin

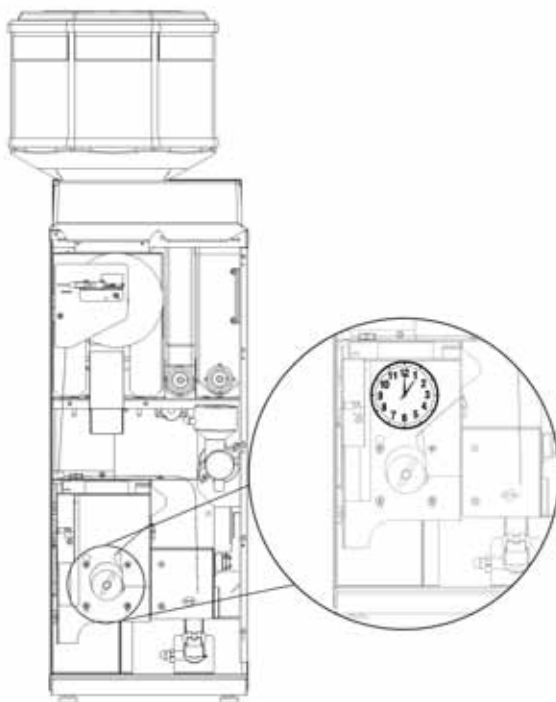

Removing the brewer

1. Open the machine door;
2. Toggle the brewer switch (SW4) to release the filter paper and cut the filter paper;
3. Remove the coffee spout and the hose support bracket from the right side of the brewer assembly;
4. Support the brewer assembly by holding the aluminum shaft on the right side of the brewer assembly;
5. With your left hand, slide the retaining pin over to the right and then down;
6. Pull the brewer assembly straight towards you.

Installing the brewer

1. Make sure that the dog drive pin in the back of the brewer is at 1 o'clock;
2. Align the left edge of the brewer on the left bracket support;
3. Push the brewer back completely into the dog drive motor;
4. Slide the brewer's retaining pin up and then left.

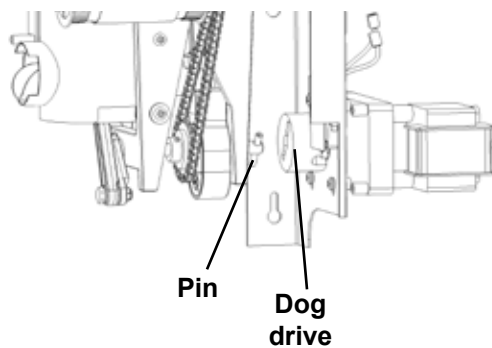

10.4 Microcontroller (EPROM)

The microcontroller, also known as the Eprom, can be swapped to incorporate new improvements to the programming such as new settings or new functions.



- Please take all counter readings before changing the microcontroller because all data will be reset.
- Use the necessary precautions for handling static sensitive devices.
- Do not attempt to pry the chip out of the socket with anything. This will damage the casing.

Tool required:

You will need to purchase a PLCC Extractor as showed in the diagram below. This can be found in most electronics stores or via the Internet. Without this tool, you may damage the casing for the microchip and damage the board.

Removing

1. Retrieve all your data;
2. Turn off the machine and unplug from the outlet;
3. Open the door and remove the lexan plate via the 4 screws;
4. Locate the microcontroller (the black square piece in the middle of the board with a white label);
5. Using the extractor, carefully insert the prongs in the top right and bottom left corner slots of the casing and grab the microcontroller;
6. Lift out from the socket gently.

Replacing

1. Align the notched corner of the microcontroller with the notched corner of the empty socket;
2. Make sure that all contacts are aligned with the appropriate slots on the socket;
3. Push the microcontroller firmly, straight down until the top of the chip is at the same level as the top of the socket;
4. Replace remaining parts in the reverse order;
5. Plug the machine in and turn on the unit;
6. At start-up, the LCD will indicate the microchip version #;
7. Test the new features outlined in the documentation supplied with the new microcontroller.

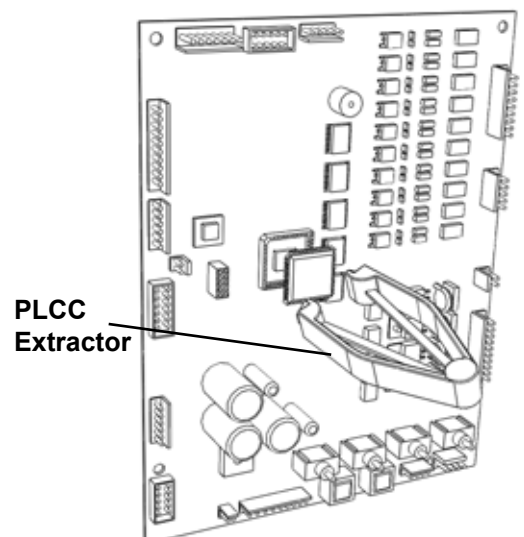
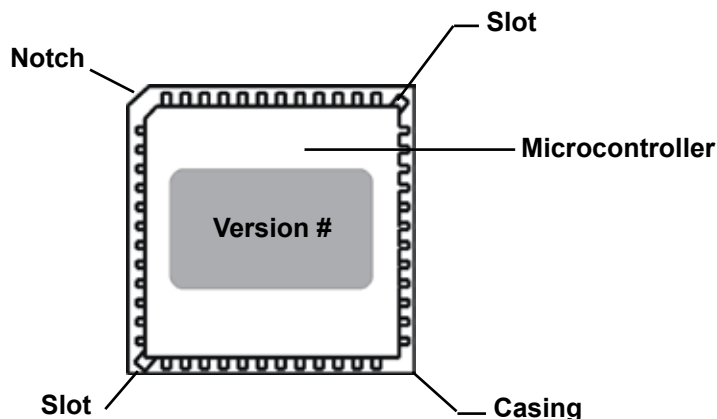

10.5 Main Board

Like all electronic main boards, they are very sensitive to power surges in the building. If this is your reason for changing the main board and this persists, verify your power source. Use the necessary precautions for handling static sensitive devices.

Removing

1. Retrieve all your data;
2. Turn off the machine and unplug from the outlet;
3. Open the door and remove the lexan plate via the 4 screws;
4. Unplug the connections:
(Clockwise from the top left corner);
 - **MDB Port** (if coinco)
 - **Main board:** J11, J12, J18, J27, J2, J19, J3, J6, J16, J24, J8, J10
5. Unscrew 4 plastic 1" posts;
6. Remove the board.

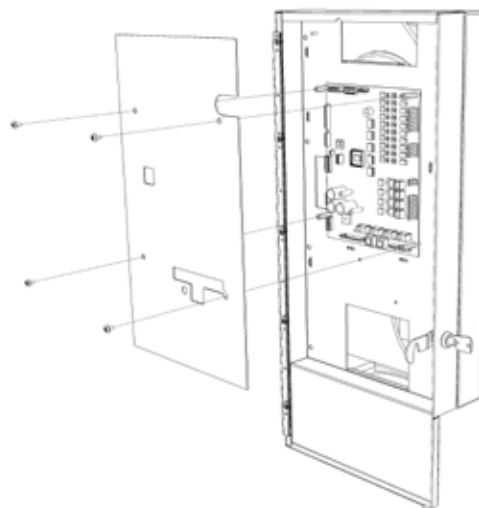

Replacing

1. Replace the board and fasten with the 4 posts;
2. Plug the connections and refer to the board diagram for full size view;
3. Verify that all is in place, the board will fail if the connections are reversed or in the wrong place;
4. Replace all parts in the reverse order;
5. Plug in the brewer and turn it on;
6. Verify on the LCD that all is functioning.

10.6 Keypad Membrane

Refer to the picture below to see which way the membrane should be placed.

Replacing

1. Turn off the machine;
2. Unlock and open the main door;
3. Remove the lexan plate via the 4 screws;
4. Unplug the connection J16;
5. Pull off the keypad membrane;
6. Slide the membrane cable through the door carefully ;
7. Install the new keypad membrane, be careful to center it;
8. Plug the connection J16 as it was (see picture below for the right position);
9. Replace the lexan plate;
10. Close and lock the main door;
11. Turn on the machine.

N.B. To make sure you installed the keypad membrane correctly run a few beverage cycles.



All cables must be replaced in the correct order and direction before turning the power on or the board will fail and be damaged.

11 TROUBLESHOOTING

11.1 "Error" Appearing on the LCD Screen

Error
Overflow Drip Tray

This message indicates that there is water in the overflow drip tray of the machine.

SOLUTION

Inspect the overflow drip tray underneath the machine to make sure it is clean and dry.

Error
Low Water Level!

This message indicates that the water level in the tank is too low.

SOLUTION

1. Check if the water gets in the tank. If so, the message on the LCD screen should disappear in a few minutes.
2. Check if the entrance of the water is working (main water source is on, inlet valve is not obstructed, etc.)
3. Inspect the overflow drip tray and make sure it is clean and dry. Even if your overflow detection is not activated, the inlet valve (DS10) won't work and it will indicate this message.
4. Check the water level switch. If there is chocolate and/or coffee on the top of the lid it might keep the switch from working properly.
5. Make sure the water level switch is properly adjusted.

Error
Brewer Error

This message indicates that the coupling (dog drive) is not at its starting position.

SOLUTION

1. This situation might arrive when the inside of the machine is soiled and the brewer switch gets wet. Clean the switch and make sure it is dry. When you will turn the machine back ON, it will reset itself.
2. Check the coupling (dog driver). If the safety pin is still in place and properly installed.
3. Make sure the brewer switch stops when the little roller of the brewer switch gets in the coupling hole. If it is not you may have to readjust the arm with pointed-nose pliers.

Change filter paper
Filter paper empty

This message indicates that the filter paper roll is empty.

SOLUTION

Make sure the filter paper roll is correctly placed. Put a new roll if it is too low. (It is normal to have 1/6 to 1/8 of paper left on the roll).

11.2 Other Message Possibilities on the LCD Screen

Change Filter Paper

This message indicates that the brewchamber is lifted up.

SOLUTION

Deactivate the brewer/paper switch on the power supply board.

Coinco not ready

Bill not detected

(These two messages scroll one after the other.)

This message indicates that the main board does not recognize the coin changer.

SOLUTION

1. Shut OFF the machine. Make sure the Coinco and bill accpetor are well plugged in. Turn the machine back ON.
2. If the coin changer still doesn't work try with another coin changer.
3. Check the J1 plug on the main board with a tester.

Make Coffee Choice

This question appears when you press on the MOKACCINO or CAFÉ LATTÉ buttons. The machine gives you 3 seconds to select the type of coffee you want. Otherwise, it takes the programmed default coffee.

Needs service
Activate Brewer

This message appears when a number of cups have been setup on the maintenance counter.

SOLUTION

To reset everything you have to put the brewer switch ON. Empty the waste basket and clean your machine thouroughly and then turn the switch OFF again.

Insert exact change

This message indicates that the coin changer's tubes are empty.

SOLUTION

Fill the tubes with change and this message will disappear.

11.3 Particular Cases

Back-up, chamber flood, bad extraction, etc.

1. Check if you are using the appropriate filter paper: Filter Paper 106 for the Platinum “La Petite-X” brewer.
2. If the problem appears with only one coffee selection, empty the canister and try another batch of the same blend.
3. Check if the brew chamber or the cylinder are cracked. In this case, the piston would pull more air than liquid.
4. If water comes out on both sides (left and right) of the brew chamber for more than 3/4 inches, you have to readjust the tension.

Element not heating

1. Check the connectors and make sure they are connected properly.
2. If the tank lid is soiled of coffee and chocolate it can affect the switches and keep them from operating correctly. In this case, change the heater safety switch.
3. Verify the condition of the element by taking out the complete tank lid.

Machine is off (doesn't work while it is turned on)

1. Check if the unit is plugged in.
2. Check if the light is ON on the plug. (Press on the Reset button if not)
3. Check if the two breakers near of the ON/OFF switch are pushed in.
4. Check and empty if necessary the overflow cup inside the machine. If the cup fills up with water again, check the water level switch. It might be because the water level switch is dirty or because it needs a little adjustment. To adjust it, slightly bend down the switch's arm (app. 1/16" should be sufficient).

Quantity of liquid too low (in cup)

Verify the machine's settings and make sure they correspond to the values given in the programming manual. Make sure the outlet valves are clean and not clogged up of lime.

Annex 1 Full maintenance schedule

PLEASE NOTE :

All major parts of your unit need to be maintained as per the schedule to honor the warranty and to prevent it from failing. With adequate maintenance you will extend the life of your unit and deliver a consistent high quality beverage

MAINTENANCE DONE BY THE OPERATOR	<p>Daily Maintenance</p> <ul style="list-style-type: none"> <input type="checkbox"/> Verify product inventory <input type="checkbox"/> Fill all canisters <input type="checkbox"/> Empty the waste basket <input type="checkbox"/> Perform a rinse cycle <input type="checkbox"/> Clean the machine and tidy area <input type="checkbox"/> Empty Bill & Coin Box (if applicable) <input type="checkbox"/> Clean the drip tray
MAINTENANCE DONE BY AUTHORIZED SERVICE PROVIDER	<p>Weekly Maintenance</p> <ul style="list-style-type: none"> <input type="checkbox"/> Verify filter paper level <input type="checkbox"/> Sanitize brew group with hot water cycle <input type="checkbox"/> Sanitize soluble mixing bowl with hot water cycle <input type="checkbox"/> Capture data from software <input type="checkbox"/> Verify overflow cup <input type="checkbox"/> Verify overflow tray <p>Monthly Maintenance</p> <ul style="list-style-type: none"> <input type="checkbox"/> Clean brewer assembly with commercial Urn Cleaner <ul style="list-style-type: none"> - Turn off Product Switch on inside of machine - Brush away any loose coffee on the brew group - remove filter paper - Clear ground coffee chute and plug with a paper towel - Sprinkle Urn Cleaner into the brew funnel directly onto the screen - Run a tall coffee cycle (make sure Product Switch is OFF)- - When the water mixes up with Urn Cleaner, stir around with a small paintbrush - When the piston lowers to the half-way point, turn off the machine - Allow the cylinder to soak for several minutes - Turn the machine back on - place cup under spout - Run several more Tall coffee cycles until water dispenses clear - Turn Product Switch on - remove paper towel from coffee chute <input type="checkbox"/> Clean coffee canisters <input type="checkbox"/> Clean coffee bean hopper and chute <input type="checkbox"/> Clean stainless coffee chute <p>Preventive Maintenance Schedule at different cycles</p> <p>5,000 cycles :</p> <ul style="list-style-type: none"> <input type="checkbox"/> Clean brewer assembly with commercial use Urn Cleaner <p>10,000 cycles :</p> <ul style="list-style-type: none"> <input type="checkbox"/> Check and replace outlet valves <input type="checkbox"/> Check and replace water filter <p>25,000 cycles :</p> <ul style="list-style-type: none"> <input type="checkbox"/> Replace brew group via replacement program <input type="checkbox"/> Replace whipping motor(s) <p>50,000 cycles :</p> <ul style="list-style-type: none"> <input type="checkbox"/> De-lime water tank and outlet valves <p>100,000 cycles or every 2 years :</p> <ul style="list-style-type: none"> <input type="checkbox"/> Replace grinder burrs <input type="checkbox"/> Replace water tank float and switches (float and heater) <p>AS NEEDED :</p> <p>The following parts should be checked on a regular basis and cleaned and sanitized as needed :</p> <ul style="list-style-type: none"> <input type="checkbox"/> Fan <input type="checkbox"/> Brew chamber <input type="checkbox"/> Whipper and mixing bowl <input type="checkbox"/> Waste bin <input type="checkbox"/> Canisters

Annex 2 Monthly maintenance schedule

PLEASE NOTE :

All major parts of your unit need to be maintained as per the schedule to honor the warranty and to prevent it from failing. With adequate maintenance you will extend the life of your unit and deliver a consistent high quality beverage.

MAINTENANCE DONE BY AUTHORIZED SERVICE PROVIDER

Monthly Maintenance

- Verify filter paper level
- Sanitize brew group with hot water cycle
- Sanitize soluble mixing bowl with hot water cycle
- Capture data from software
- Verify overflow cup
- Verify overflow tray
- Clean brewer assembly with commercial Urn Cleaner
 - Turn off Product Switch on inside of machine
 - Brush away any loose coffee on the brew group - remove filter paper
 - Clear ground coffee chute and plug with a paper towel
 - Sprinkle Urn Cleaner into the brew funnel directly onto the screen
 - Run a tall coffee cycle (make sure Product Switch is OFF)-
 - When the water mixes up with Urn Cleaner, stir around with a small paintbrush
 - When the piston lowers to the half-way point, turn off the machine
 - Allow the cylinder to soak for several minutes
 - Turn the machine back on - place cup under spout
 - Run several more Tall coffee cycles until water dispenses clear
 - Turn Product Switch on - remove paper towel from coffee chute
- Clean coffee canisters
- Clean coffee bean hopper and chute
- Clean stainless coffee chute

Check, clean and sanitize as needed :

- Fan
- Brew chamber
- Whipper and mixing bowl
- Waste bin
- Canisters

Preventive Maintenance Schedule at different cycles

- 5,000 cycles :
 - Clean brewer assembly with commercial use Urn Cleaner
- 10,000 cycles :
 - Check and replace outlet valves
 - Check and replace water filter
- 25,000 cycles :
 - Replace brew group via replacement program
 - Replace whipping motor(s)
- 50,000 cycles :
 - De-lime water tank and outlet valves
- 100,000 cycles or every 2 years :
 - Replace grinder burrs
 - Replace water tank float and switches (float and heater)

Annex 3 Weekly maintenance schedule

PLEASE NOTE :

All major parts of your unit need to be maintained as per the schedule to honor the warranty and to prevent it from failing. With adequate maintenance you will extend the life of your unit and deliver a consistent high quality beverage.

MAINTENANCE DONE BY AUTHORIZED SERVICE PROVIDER	<p>Weekly Maintenance</p> <ul style="list-style-type: none"> <input type="checkbox"/> Verify filter paper level <input type="checkbox"/> Sanitize brew group with hot water cycle <input type="checkbox"/> Sanitize soluble mixing bowl with hot water cycle <input type="checkbox"/> Capture data from software <input type="checkbox"/> Verify overflow cup <input type="checkbox"/> Verify overflow tray <p>Check, clean and sanitize as needed :</p> <ul style="list-style-type: none"> <input type="checkbox"/> Fan <input type="checkbox"/> Brew chamber <input type="checkbox"/> Whipper and mixing bowl <input type="checkbox"/> Waste bin <input type="checkbox"/> Canisters
	<p>Preventive Maintenance Schedule at different cycles</p> <p>5,000 cycles :</p> <ul style="list-style-type: none"> <input type="checkbox"/> Clean brewer assembly with commercial use Urn Cleaner <p>10,000 cycles :</p> <ul style="list-style-type: none"> <input type="checkbox"/> Check and replace outlet valves <input type="checkbox"/> Check and replace water filter <p>25,000 cycles :</p> <ul style="list-style-type: none"> <input type="checkbox"/> Replace brew group via replacement program <input type="checkbox"/> Replace whipping motor(s) <p>50,000 cycles :</p> <ul style="list-style-type: none"> <input type="checkbox"/> De-lime water tank and outlet valves <p>100,000 cycles or every 2 years :</p> <ul style="list-style-type: none"> <input type="checkbox"/> Replace grinder burrs <input type="checkbox"/> Replace water tank float and switches (float and heater)