



4" C.D. Worm Gear Reducer INSTALLATION MANUAL



SYSTEM DESCRIPTION

The Gear Box is the Worm Gear Reducer used in many palletizing systems. There is a L.H. Gear Box, a R.H. Gear Box and a Shaft Mounted *Posistop* Brake. The Gear Boxes are identical except for Shaft Orientation. This manual covers the Installation for both the L.H. and R.H. Gear Boxes. See Manuals indicated below for the *Posistop* Shaft Mounted Brake.

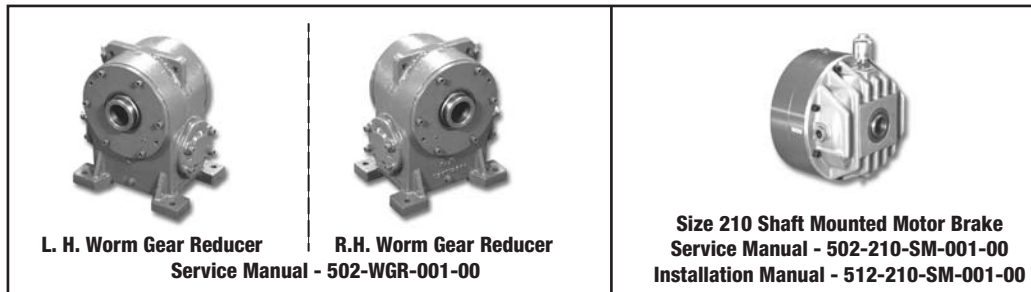

WORM GEAR REDUCER FEATURES

The Worm Gear Reducer Cross Section below shows the Gear Box and it's many features.

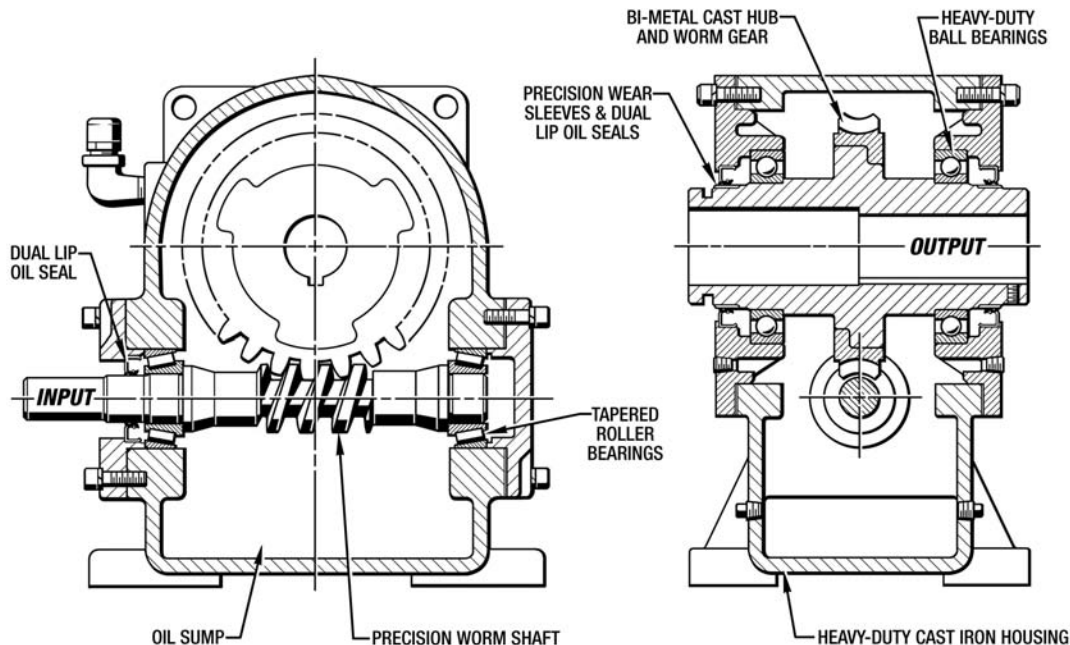

Gear Reducer Operating Specifications

INPUT SPEED (RPM)	1750	1250	900	625
INPUT HP	5.77	5.05	4.28	3.40
OPERATING TORQUE (In. Lbs.)				
TORQUE-INPUT	207	254	299	342
TORQUE-OUTPUT	3,702	4,468	5,168	5,768
EFFICIENCY	89%	88%	86%	84%

Gear Box Weight - 139 Lbs.

Gear Reducer Dimensions

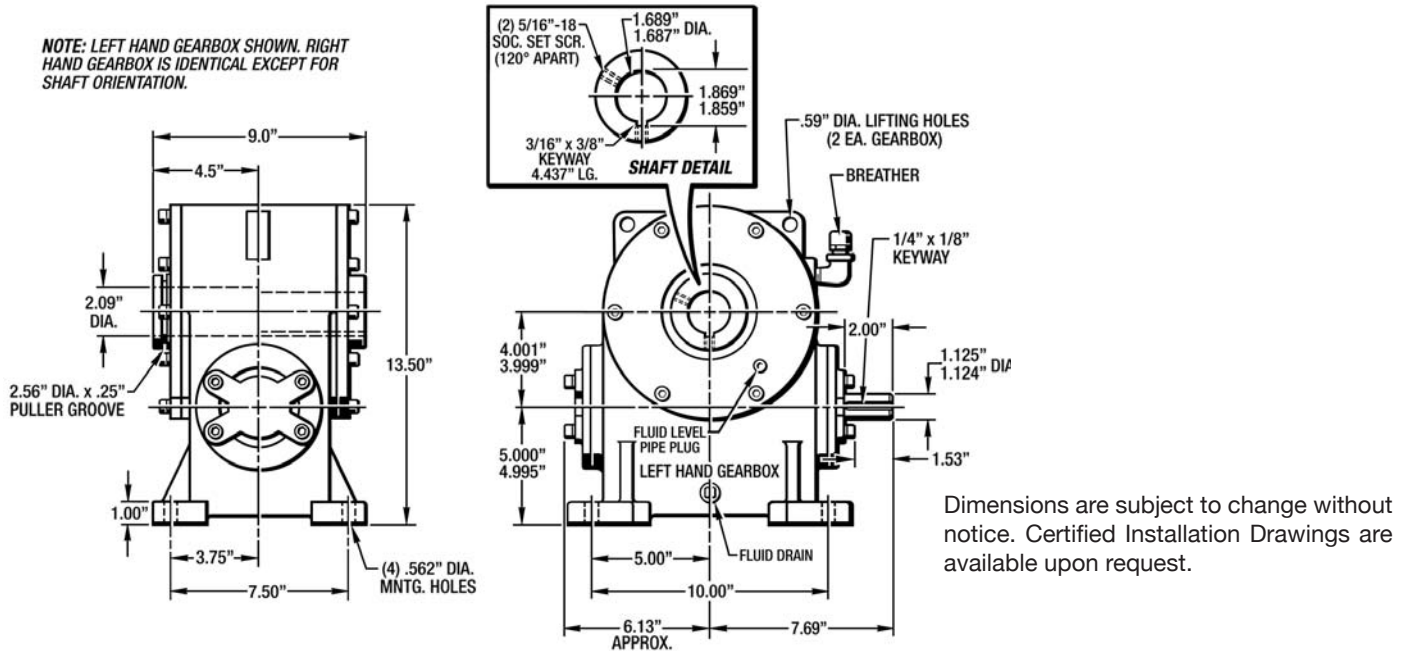

Important Safety Precautions

THIS SECTION ONLY PERTAINS TO PALLETIZER SYSTEMS.

WARNING: THE GEAR REDUCER UNIT DESCRIBED IN THIS MANUAL MUST NOT BE INSTALLED IN ANY MANNER EXCEPT AS SPECIFIED HEREIN, AND MUST NOT BE OPERATED AT SPEEDS, TORQUE LOADS, OR TEMPERATURES OTHER THAN THOSE SPECIFIED IN THIS MANUAL. FAILURE TO LIMIT OPERATIONS OF THE GEAR REDUCER TO THE CONDITIONS SPECIFIED COULD DAMAGE THE UNIT, WILL VOID ANY WARRANTIES, AND MAY CAUSE MALFUNCTIONS OR DAMAGE TO INTERCONNECTING EQUIPMENT.

CAUTION: BEFORE PERFORMING ANY WORK ON THE GEAR BOX, TAKE THE FOLLOWING SAFETY PRECAUTIONS.

A. INITIAL PROCEDURE

1. Lower the main hoist to the down position.
2. After the main hoist has been safely positioned, the machine must be made safe to enter.

Push one of the Emergency Stop buttons located at the following: A. Main Electrical Panel, B. Main Hoist Frame, C. Pallet Magazine Remote, D. Remote Control Panel on top of the palletizer.

CAUTION: DO NOT ENTER THE MACHINE YET.

If maintenance must be performed on the machine, the main power must be locked out at the main electrical control panel.

CAUTION: THE HOIST MUST BE IN THE DOWN POSITION.

B. MAIN PANEL LOCKOUT PROCEDURE

Turn the Main Power Disconnect switch to the OFF position at the Main Electrical Control Panel.

Insert a lock into the switch, and place an identifier tag

at the lock to indicate the machine is being worked on by you and why.

NEVER REMOVE A LOCKOUT UNLESS YOU HAVE PERMISSION TO.

Now try to operate some of the controls. The machine should not operate. If the machine will operate call a qualified maintenance technician.

REMEMBER TO "LOCKOUT & TRY OUT"

If the palletizer will not operate it is safe to enter the machine.

3. Manually release the existing brake. The main hoist should move downward slightly and come to rest on the lower frame of the palletizer. If not, reset the brake and install cribbing to support the main hoist to prevent it from moving down.
4. The drive shaft connecting the motor and reducer high speed shafts must be removed to access the brake. Match mark the drive shaft couplings so that machine timing can be restored when the brake installation is complete. Remove the drive shaft and set aside.

Gear Reducer Installation

A. RECEIVING THE WORM GEAR REDUCER

1. Remove the red plastic pipe plug in the side of the Gear Reducer Housing and install the Street Elbow (#836) and the Air Breather (#832).

WARNING: Failure to install the Air Breather (#832) properly could cause damage to the unit and void the Warranty.

2. Check the fluid level as indicated in Lubrication on page 4. Add fluid if necessary.

B. MOUNTING THE WORM GEAR REDUCER

(See Figure Below)

Use 1/2"-13 SAE Grade 5 Hex Hd. Mounting Bolts and Lockwashers.

Make sure the mounting surface is thoroughly cleaned and free of any burrs or surface defects that would cause misalignment.

1. Check the fit for the Thru-Shaft by sliding the Thru-Shaft back and forth through the hub bore to make sure that it is a smooth slip-fit.

Check the fit of the Thru-Shaft with the Key installed. Make sure that there is no binding around the keyway.

NOTE - Use *Never-Seeze* or a good synthetic high temperature grease on the shaft and key.

2. Install the Gear Reducer on the machine. Only hand tighten the mounting bolts at this time.
3. Install the Thru-Shaft and tighten the Pillow Block Bearings.
4. Align the Input Shaft to the Power Source. Use an adequate non backlash coupling. Make sure the Axial, Parallel and Angular Alignment is correct as per the Couplings Manufacturers' Alignment Specifications.
5. Shim under the motor as needed to assure correct alignment.

NOTE - If the Thru-Shaft determines the vertical position of the gear box, you may also have to shim under the gear box feet to accommodate for any vertical space to the mounting surface.

6. Tighten down mounting bolts. Torque to 60 Lb. Ft.
7. After the Worm Gear Reducer has been in operation for a few hours, make sure the mounting bolts are tight and re-check alignment.
8. After the Worm Gear Reducer has been in operation for 40 hours, make sure the mounting bolts are still tight. Tighten if necessary.

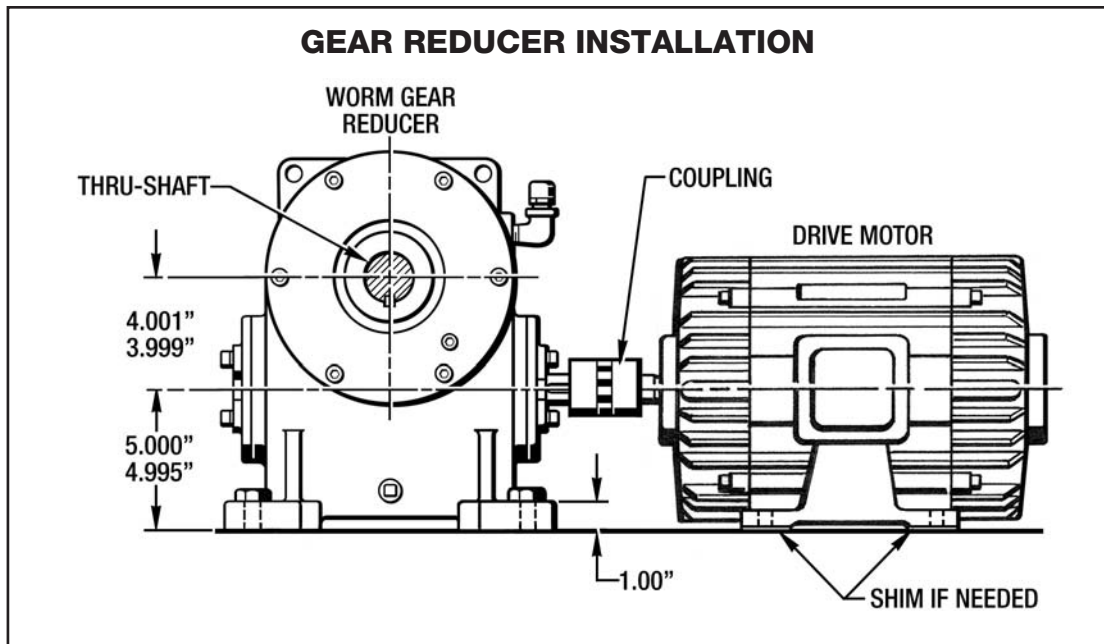

Gear Reducer Lubrication

A. CHECKING THE OIL LEVEL

Check the oil level when the drive is installed and weekly thereafter (until experience dictates otherwise). Always check the oil level with the unit stationary (not running). The oil level should be at the bottom of the pipe plug hole. **NOTE** - The Oil Level Pipe Plugs (#835) are on both sides so the oil level is visible from either side. See Gear Reducer Lubrication Figure.

B. CHANGING THE OIL

Oil in the Worm Gear Reducer should be changed every twelve (12) months. More frequent oil change may be required for high kinetic energy applications or in extremely dirty environments.

Remove the Drain Plug (#834) at the bottom of the main housing. Drain all oil before refilling. Replace the drain plugs. Remove Breather (#832) and Oil Level Plug (#835). Refill unit with clean oil until oil comes up to the oil level hole and replace Pipe Plug (#835) and the Breather (#832).

WARNING: Failure to install the Air Breather (#832) properly could cause damage to the unit and void the Warranty.

CAUTION: Do not over-fill. Excess oil will cause the unit to overheat.

C. TYPE OF OIL

Use Mobilgear 634 or 600W Cylinder Oil ONLY (Unless otherwise specified on the unit nameplate).

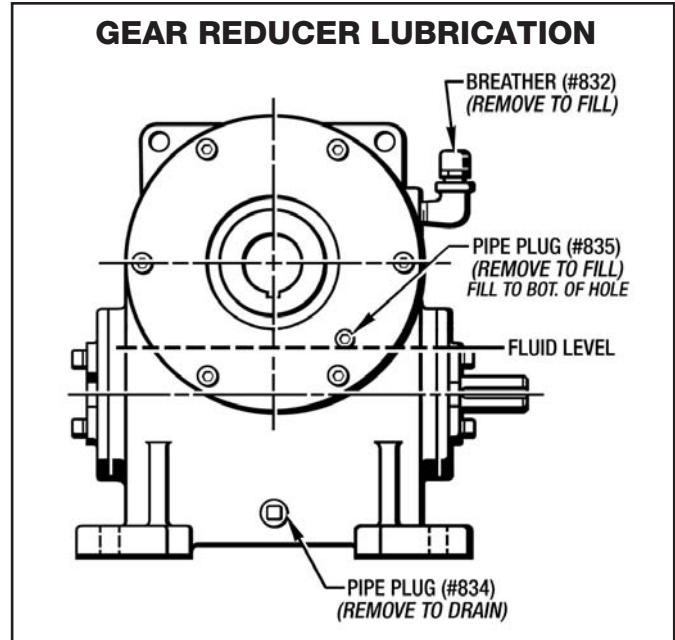

Factory Rebuild Service Maintenance and Service Manuals

A. FACTORY REBUILD SERVICE

A Factory Re-Build Service is offered by Force Control Industries, Inc. Contact our service and sales department at Force Control for additional information.

B. MAINTENANCE AND SERVICE MANUALS

A complete Service Manual can be downloaded and printed off of our web site or ordered directly from Force Control. It is as follows:

Service Manual and Repair Parts for the 4" C.D. Worm Gear Reducer is 502-WGR-001-00

Go to: www.forcecontrol.com

All of our Catalogs and Service Manuals on the web site are in PDF format and will require Adobe Acrobat Reader 5.0 or later to open them. This Adobe Acrobat Reader can be downloaded from our web site if you do not have it installed on your computer.



FORCE CONTROL INDUSTRIES, INC.

3660 Dixie Highway
Fairfield, Ohio 45014

Phone: 513-868-0900
Fax: 513-868-2105

E-Mail: info@forcecontrol.com
Web Site: www.forcecontrol.com