

Fellowes®

POWERSHRED®

OPERATING INSTRUCTIONS
NOTICE D'UTILISATION
MANUAL DEL PROPIETARIO
BETRIEBSANLEITUNG

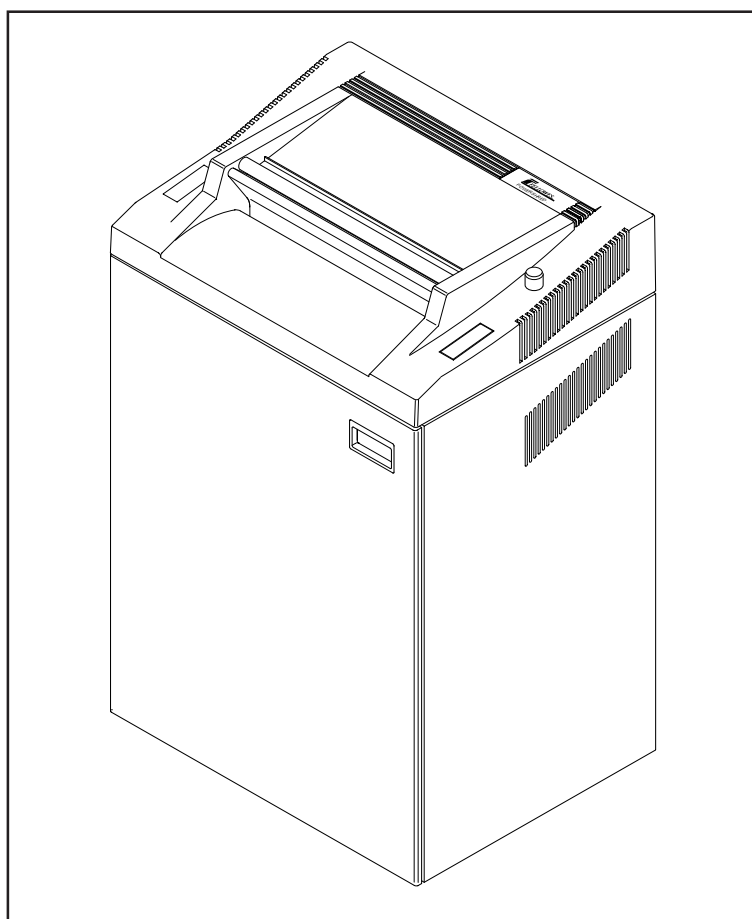

520
520CC
520HS

Ⓤ	Paper shredder Fellowes 520/520 CC/520 HS	3–8
ⓕ	Déchiqueteuse Fellowes 520/520 CC/520 HS	9–14
ⓔ	Destruccora de documentos Fellowes 520/520 CC/520 HS	15–20
ⓓ	Aktenvernichter Fellowes 520/520 CC/520 HS	21-26

Contents	Page
1. Important Safety Instructions	4
2. Parts Identification	4
3. Technical Specifications	5
4. Supplies	6
5. Installation	6
6. Caution	6
7. Operation	6
8. Malfunctions	7
9. Maintenance	7
10. Checklist for Inoperative Machine	7
11. Warranty	8
12. Customer Service	8

1. Important Safety Instructions

1. Read all instructions before use.
2. Save these instructions for later use.
3. Follow all warnings and instructions marked on the product.
4. Unplug this product from the wall outlet before cleaning. Clean with a damp cloth using a mild soap and water solution. (Do not use abrasives or petroleum based cleaners.)
5. Place this product as close as possible to power source for quick and easy unplugging.
6. Do not use this product near water.
7. This product should never be placed near or over a radiator or heat source.
8. Operate from the type power source indicated on the marking label. If you are not sure of the type of power available, consult your dealer or local electricity board.
9. Do not allow anything to rest on the power cord. Do not place this product where people may walk on the cord.
10. If an extension cord is used with this product, make sure that the total of the ampere ratings on the products plugged into the extension cord do not exceed the extension cord ampere rating. Also, make sure that the total of all products plugged into the wall outlet does not exceed 15 amps.
11. Do not attempt to service this product yourself, as opening or removing covers may expose you to dangerous live parts or other risks.
12. Unplug this product and refer servicing to qualified personnel under the following conditions:
 - A) When the power cord or plug is damaged or frayed.
 - B) If liquid has been spilled on the product.
 - C) If the product has been exposed to rain.
 - D) If the product does not operate normally when the operating instructions are followed.
 - E) If the product has been dropped or the casing has been damaged.
13. Keep out of the reach of children.
14. This shredder should be operated only with an operator in attendance.

2. Parts Identification

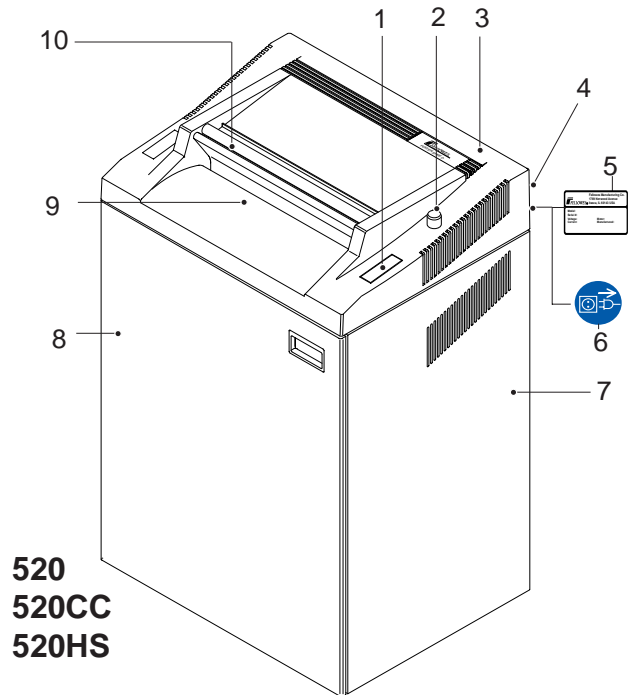

520
520CC
520HS

- | | |
|-----------------------------------|------------------------|
| 1. Membrane keyboard | 6. Caution label |
| 2. Security key lock (520HS only) | 7. Cabinet |
| 3. Cover | 8. Cabinet access door |
| 4. Main power switch | 9. Paper feed opening |
| 5. Serial Label | 10. Paper guide roller |



Ready for operation

green LED



Cut material bag full

red LED



Paper jam – electric motor overloaded

red LED



Front door not closed

red LED



On

shredder is switched on – cutting system runs forward



Stop

cutting head stops – shredder remains ready for operation



Reversing

cutting system runs in reverse

3. Technical Specifications

	Model 520		Model 520CC		Model 520HS
Cutting style	Strip cut		Cross cut		High Security Cross cut
Shred size	5/32" (3.9mm)	1/4" (5.8mm)	5/32" x 2" (3.9 x 50mm)	1/16" x 5/8" (1.9 x 15mm)	1/32"x7/16" (.78 x 11mm)
Security rating DIN 32757-1	2	2	3	4	5
*Sheet capacity - 8-1/2" x 11" - 20 lb. A4, 70g/m ² (16 lb.)	28 35	36-38 50	26-28 32	19 23	11-12 15
Speed	32 FPM (143 mm/s)		25 FPM (100 mm/s)		25 FPM (100 mm/s)
Entry width	16" (400 mm)		16" (400 mm)		16" (400 mm)
Motor power	1 H.P. (0.8 kw)		1 H.P. (0.8 kw)		1 H.P. (0.8 kw)
Input voltage (Depending on country)	100 V, 50 Hz 115 V, 60 Hz 220/240 V, 50 Hz		100 V, 50 Hz 115 V, 60 Hz 220/240 V, 50 Hz		100 V, 50 Hz 115 V, 60 Hz 220/240 V, 50 Hz
Dimensions	23 ¹ / ₂ " x 18 ¹ / ₂ " x 35 ³ / ₄ " (595 x 470 x 918 mm)				
Weight	180 lbs. (82 kg)		194 lbs. (88 kg)		194 lbs. (88 kg)
Waste container volume	41.2 gallons (156 liters)				
Noise level	In idle 60dB - Under load 68 dB strip cuts and 75 dB cross cuts				

* Ppaper-DIN 19307 SM 4a - 70

4. Supplies

- Bags for cut material
(Packed in dispenser carton, 50 or 100 bags to a roll depending on size. Contact Fellowes or your local Fellowes dealer for the stock number of the bag that fits your machine.)
- Cutting block oil for cross-cut units
Stock # 35250

5. Installation

- Refer to separate set-up instructions for proper assembly
- Operate this product only from the type of power source indicated on the marking label
- Install the paper shredder so that the plug is easily accessible
- Shredder must be operated only in upright position
- Set up paper shredder so that the ventilation slots are unobstructed. To ensure sufficient ventilation of the shredder a minimum distance of 4" (10 cm) to the wall or to the furniture must be maintained.

6. Caution



Never insert hand, fingers or any foreign objects into the feed opening.

Serious injury may result.



Keep all loose articles of clothing, ties, jewelery, long hair or other loose objects away from feed opening.

Injury may result.

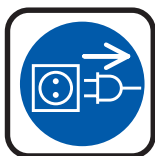

Always turn off and unplug the machine before moving, servicing, cleaning or any other conduct other than normal operation.

Serious injury may result.

7. Operation



Read operating instructions **before** putting shredder into operation



Insert plug in power outlet

Install waste bag for shredded material

- Open front door and completely remove bag frame from cabinet
- Fold new bag around frame.
Allow bag to overhang frame by approximately 7" (20 cm).
- Slide frame with bag back into cabinet
- Close cabinet door.

Switching equipment on



- Set main power switch (located on back of shredder) to ON (1) position.
- (On the 520 HS, the security key lock switch must also be turned on)



- Green LED lights
- Equipment is ready for operation (standby)

To shred paper



- Press green arrow button at least 4 sec
- Cutting system runs in forward direction

- Insert paper into the paper feed opening
- Shredding occurs
- or
- Feed paper
- The shredding process is started by a photo-cell in the paper feeding opening

When the paper feeding opening is free again, the cutting system automatically switches off after approx. 3 sec. and returns to standby.

When shredding is completed



- Push stop button
- Cutting system stops
- Equipment returns to "ready-to-operate" (standby) condition

Switching equipment off



- Set main power switch (located on back of shredder) to OFF (0) position.

Feeding continuous forms

- Pass the leading edge of the form under the paper guide roller (1) and into the paper feed opening (2).

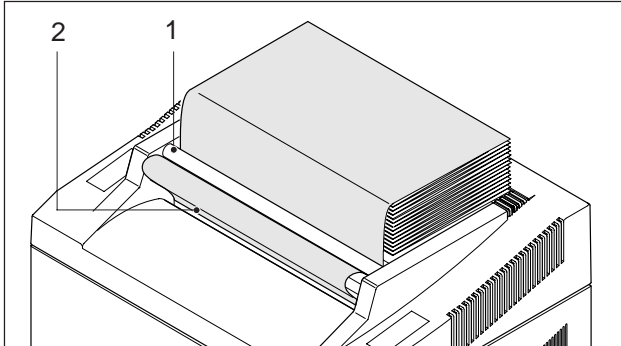

8. Malfunctions

Paper jam



- Red LED on keyboard lights
- Shredder reverses automatically and runs in this mode for a few seconds.
- Pull out jam and remove excess paper.



Caution!

Do not attempt to force the jammed material through the machine by alternating the cutting system between forward and reverse.



If paper jam cannot be removed



- Hold down reverse button until paper can be pulled out of the cutting system.



- Press green arrow button at least 4 sec
- Continue shredding in smaller quantities so as not to jam the machine further.
- or
- Continue shredding in smaller quantities so as not to jam the machine further.
- The shredding process is started by a photo-cell in the paper feeding opening

Note:

The 520 HS will not run forward again unless the jammed material has been completely removed from the throat.

Electronic motor overheated



- Red LED on keyboard lights
- Shredder switches off automatically.

- Allow shredder to cool down for approx. 15-20 min.



- Press green arrow button at least 4 sec

Cabinet door contact ajar / bag full



- Red LED lights
- Shredder switches off automatically.



- Make sure cabinet door is properly closed and/or empty waste container.



- Press green arrow button at least 4 sec

9. Maintenance

(Cross cut unit only)

- When shredding capacity drops or the noise increases.
- Spray special cutting block oil onto cutting system.



- Run cutting system forward and backward several times without feeding paper.



- Continue shredding.

10. Checklist for Inoperative Machine

If the equipment does not work properly, please check the following points first:

- Is the plug inserted?
- Is the switch turned on?
- Is the cabinet door closed?
- Is the waste receptacle full?
Empty waste bag.
- Is there a paper jam in the shredder?
See Malfunctions
- Is the motor overheated?
Switch machine off and allow motor to cool down for approximately 15-20 min.

If none of the above applies and the equipment still does not run, please contact our customer service department.

11. Warranty

FELLOWES® POWERSHRED LIMITED WARRANTY

1 year on all parts and labor
5 years parts and labor on cutting cylinders

Fellowes® warrants this product to be free from defects in material and workmanship for a period of one year from the date of purchase by the original consumer. At it's option, Fellowes® will repair or replace without charge for material or labor, any component found to be defective during the warranty period. Additionally, the cutting cylinders are warranted for 5 years from the original purchase date and will be replaced without charge for material or labor if found by Fellowes® to be defective.

Warranty Exclusions

The parties agree that the buyer's sole and exclusive remedy against Fellowes® shall be for the repair or replacement of defective parts as provided herein. The buyer agrees that no other remedy (including, but not limited to, incidental or consequential damages for lost profits, lost sales, injury to property or any other incidental or consequential loss) shall be available to him. This warranty shall NOT apply and is void under the following circumstances:

1. When this product or any part thereof has been subjected to accident, alteration, abuse, or misuse.
2. When the original Model and Serial Number Plate has been altered, effaced or removed.
3. When repair or service covered under this warranty (other than routine maintenance (as described in the *Owner's Manual*) has been performed by personnel without the express written consent of Fellowes®.
4. When the product has been used pursuant to any verbal or written rental, lease or loan agreement.

THIS WARRANTY DESCRIBED HEREIN SHALL BE IN LIEU OF ANY OTHER WARRANTY, EXPRESSED OR IMPLIED, INCLUDING, BUT NOT LIMITED TO, ANY IMPLIED WARRANTY OF MERCHANTABILITY OR FITNESS FOR A PARTICULAR PURPOSE. ANY REPRESENTATIONS OR PROMISES INCONSISTENT WITH OR IN ADDITION TO THIS WARRANTY ARE UNAUTHORIZED AND SHALL NOT BE BINDING UPON FELLOWES.

12. Customer Service

United States

Fellowes Manufacturing Co.
1789 Norwood Avenue
Itasca, IL 60143
Tel.: 1-800-955-0959

Canada

Fellowes Manufacturing of Canada Ltd.
2750 John Street
Markham, Ontario L3R 2W4
Tel.: 1-800-665-4339

United Kingdom

Fellowes Manufacturing UK Ltd.
Doncaster Road
Kirk Sandall
Doncaster, South Yorkshire DN3 1HT
Tel.: 01302-885 331

Australia

Fellowes Manufacturing (Australia) Pty.Ltd.
10 Fellowes Court
Tullamarine, Victoria 3043
Tel.: (03) 9330-3211 in Melbourne
1-800-331-177 outside Melbourne

Nederland

Fellowes
P.O. Box 180
4130 Ed Vianen
Nederland
Tel.: 0347-377988

Germany

Fellowes GmbH
Dieselstraße 27
D-30827 Garbsen
Tel.: 05131-49770

France

Fellowes Lynx S.A.
194 allée de la Croix des Hormes
69250 Montanay
Tel.: 33-72-08-25-50