

# SERVICE MANUAL

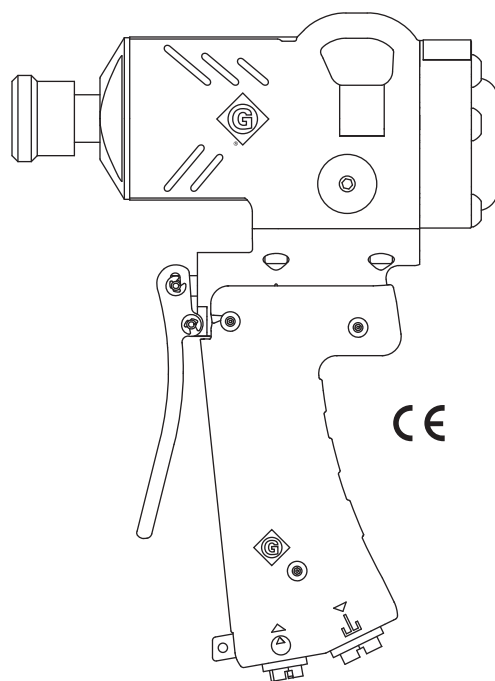

## HW1 Impact Wrench

Serial Code BBA



**Read and understand** all of the instructions and safety information in this manual before operating or servicing this tool.

Register this product at [www.greenlee.com](http://www.greenlee.com)

## Table of Contents

Safety .....	2
Purpose of this Manual .....	2
Other Publications .....	2
Important Safety Information .....	3-4
Disassembly .....	5-6
Inspection .....	6
Assembly .....	7-8
Illustrations and Parts List .....	9-11
Accessories .....	12

## Safety

Safety is essential in the use and maintenance of Greenlee tools and equipment. This manual and any markings on the tool provide information for avoiding hazards and unsafe practices related to the use of this tool. Observe all of the safety information provided.

## Purpose of this Manual

This manual is intended to familiarize all personnel with the safe service procedures for the following Greenlee Utility tool:

HW1 Serial Code BBA

Keep this manual available to all personnel.

Replacement manuals are available upon request at no charge at [www.greenlee.com](http://www.greenlee.com).

## Other Publications

Operation Manual: Publication 52060654

SAE Standard J1273 (Hose and Hose Assemblies):  
Publication 99930323

All specifications are nominal and may change as design improvements occur. Greenlee Textron Inc. shall not be liable for damages resulting from misapplication or misuse of its products. Super Spool is a trademark of Greenlee Textron Inc. Loctite is a registered trademark of Loctite Corporation. Mobilgrease is a registered trademark of Mobil Oil Corporation. Super Spool is protected by U.S. Patent No. 4548229.

# ***KEEP THIS MANUAL***

**IMPORTANT SAFETY INFORMATION**



**SAFETY  
ALERT  
SYMBOL**

This symbol is used to call your attention to hazards or unsafe practices which could result in an injury or property damage. The signal word, defined below, indicates the severity of the hazard. The message after the signal word provides information for preventing or avoiding the hazard.

**⚠ DANGER**

Immediate hazards which, if not avoided, **WILL** result in severe injury or death.

**⚠ WARNING**

Hazards which, if not avoided, **COULD** result in severe injury or death.

**⚠ CAUTION**

Hazards or unsafe practices which, if not avoided, **MAY** result in injury or property damage.



**⚠ WARNING**

Skin injection hazard:

- Do not use hands to check for leaks.
- Do not hold hose or couplers while the hydraulic system is pressurized.
- Depressurize the hydraulic system before servicing.

Oil under pressure easily punctures skin causing serious injury, gangrene, or death. If you are injured by escaping oil, seek medical attention immediately.

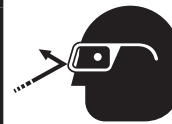

**⚠ WARNING**

Wear eye protection when operating or servicing this tool.

Failure to wear eye protection could result in serious eye injury from flying debris or hydraulic oil.



**⚠ WARNING**

Tool and accessory may be hot during and after operation.

Contact with hot surfaces could result in serious injury.



**⚠ WARNING**

Read and understand all of the instructions and safety information in this manual before operating or servicing this tool. Refer also to the Operation Manual listed under "Other Publications."

Failure to observe this warning could result in severe injury or death.

## **IMPORTANT SAFETY INFORMATION**

### **⚠ WARNING**

Do not exceed the following hydraulic power source maximums:

- Hydraulic flow: 46 l/min (12 gpm)
- Pressure relief: 138 bar (2000 psi)
- Back pressure: 13.8 bar (200 psi)

Failure to observe this warning could result in severe injury or death.

### **⚠ WARNING**

Do not reverse hydraulic flow. Operation with hydraulic flow reversed can cause tool malfunction. Connect the supply (pressure) hose and return (tank) hose to the proper tool ports.

Failure to observe this warning could result in severe injury or death.

### **⚠ WARNING**

Do not disconnect tool, hoses, or fittings while the power source is running or if the hydraulic fluid is hot. Hot hydraulic fluid could cause serious burns.

### **⚠ WARNING**

Do not change accessories, inspect, or clean tool when it is connected to a power source. Accidental start-up can result in serious injury.

Failure to observe this warning could result in severe injury or death.

### **IMPORTANT**

Procedure for connecting or disconnecting hydraulic hoses, fittings, or components:

1. Move the flow lever on the hydraulic power source to the OFF position.
2. Stop the hydraulic power source.
3. Follow the sequence under “Hose Connections” in the Operation Manual to prevent pressure buildup. In case some pressure has built up, loosen hoses, fittings, or components slowly.

*Note: Keep all decals clean and legible, and replace when necessary.*

## Disassembly

Complete disassembly of the tool is not recommended. If a complete overhaul is necessary, return the tool to your nearest Greenlee Utility Authorized Service Center.

The disassembly procedure is divided into sections of the tool. Disassemble only the section(s) necessary to complete the repair.

Disassemble the tool on a flat, clean surface. Take care not to lose or damage any parts that may fall free during disassembly.

In order to simplify the disassembly and assembly instructions, refer to "Tool Orientation" below to identify the sides and ends of the tool.

### Tool Orientation

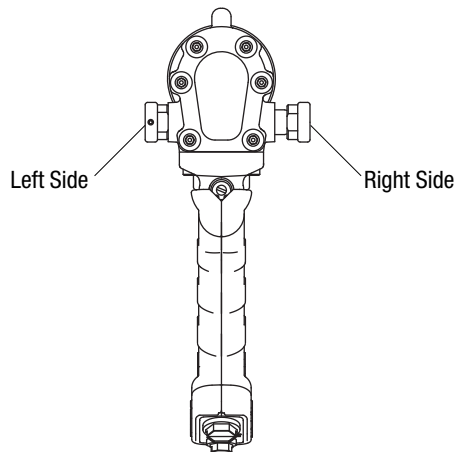
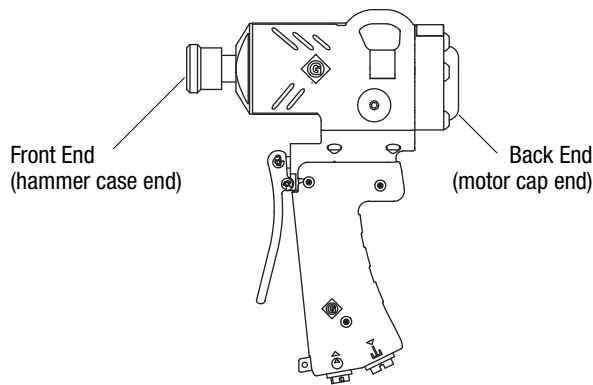

### Quick-Change Chuck

1. Slide the thrust ring (61) back to expose thrust ring lock (60). Remove thrust ring lock, thrust ring, and spring (62).
2. Slide the retaining sleeve (59) off of the anvil (58) and remove three steel balls (63).

### Hammer Case Components

1. Using a wrench on the flats of the hammer case cap (41), unscrew and remove the cap.
2. Remove the anvil (58), hammer frame (55), hammer (56), and hammer pin (57).
3. Remove spacer (40), thrust bearing (38), and thrust washers (39) from hammer case cavity.

### Motor

1. Remove cap screws (16) and remove motor cap (7) from head (1). Remove O-ring (15). Remove dowel pins (14).
2. Remove retaining ring (11) from idler shaft (13). Pull idler shaft (13) with gear (10) from handle. Remove gear from idler shaft. Remove the drive pin (12) from idler shaft.
3. Remove retaining ring (11), gear (10), and Woodruff key (9) from drive shaft (8). Push drive shaft toward hammer case end and remove it from the handle.

### Trigger and Super Spool™

1. Remove clips (47) from pins (46). Remove pins from handle (5) and trigger spool (29).  
*Note: If trigger spool is not supported by covers (48, 49), it may slide out the back.*
2. Remove snap ring (35), washer (34), and spring (36). Push trigger spool (29) out of handle (toward front of tool).

3. Remove the retaining ring (32).

*Note: Perform Step 4 over an empty container to catch the steel ball (31) when it falls free.*

4. Remove Super Spool (30) and O-ring (33).
5. Remove O-ring (64) from spool (29).
6. Remove O-ring (27) and backup ring (28) from handle (5).

## Disassembly (cont'd)

### Reversing Spool

1. Loosen set screws (21, 22) from cap (23) on left side of tool. Remove cap (23) and pull reversing spool (17) out of right side of tool.

*Note: Attempting to push the reversing spool the opposite way through the bore will damage the O-rings and could allow particles of O-ring to get into the motor.*

2. Remove plug (20), spring (19), and poppet (18).
3. Remove O-ring (26) from plug (20).
4. Remove O-ring (27) and backup ring (28) from head (1).
5. Remove O-ring (24) and backup ring (25) from spool (29).

### Handle and Head

1. Remove plastic covers (48, 49) by removing screws (51).
2. Remove screws (44) from handle (5) to separate head (1) from handle.
3. Remove dowel pins (45) and O-rings (33).
4. Remove snap ring (52), ball stop (53), and ball (54).

## Inspection

Clean all parts with solvent and dry them thoroughly. Inspect each component as described in this section. Replace any component that shows wear or damage.

1. Bearings: Insert shaft into bearing. Spin shaft. If shaft does not spin smoothly, replace the entire assembly with the bearings already pressed in.
2. Motor cap and handle: Inspect mating surfaces, gear cavities, oil passageways, etc. for grooves or nicks. If any component shows wear or damage, replace the entire assembly with the bearings already pressed in.
3. Thrust rings: Replace any thrust ring that is out-of-round or has been sprung.
4. Bearing (inside hammer case cap): Slide the anvil into the bearing. Spin the anvil. If the anvil does not turn smoothly, inspect the bearing surface. If the bearing surface shows uneven wear, replace hammer case cap as an assembly with the bearing already pressed in.
5. Thrust bearing and thrust washers: Spin the bearing against the washers. If bearing does not spin smoothly, replace the bearing and washers.
6. Inspect all other disassembled components for cracks, grooves, or nicks.

## Assembly

Refer to the Illustrations and Parts List for correct orientation and placement of parts.

Replace any O-rings, V-rings, seals, and gaskets on parts that have been disassembled. Apply hydraulic fluid or O-ring lubricant to all O-rings and all metal surfaces which they must slide over. When installing an O-ring which must slide over sharp surfaces, use a rolling motion and be careful not to damage the O-ring.

Wherever the assembly results in metal-to-metal contact, coat the surfaces with hydraulic fluid or O-ring lubricant.

### Handle and Head

1. Install ball (54), ball stop (53), and snap ring (52) on the return port of the handle (5).
2. Install dowel pins (45) and three O-rings (33) onto handle (5). Install four screws (44) through handle (5) and into head (1). Torque screws to 14.3 Nm (130 in-lb).  
*Note: Ensure O-rings stay in grooves when connecting handle to head. O-rings can be secured in place with O-ring lubricant.*
3. Install plastic covers (48, 49) using screws (51) and nuts (50). Nuts should be placed in right cover (49). Torque screws until covers (48, 49) fit snug.

### Motor

1. Use an O-ring tool to install a new O-ring (3) from the back end of the head (1).
2. Lubricate drive shaft (8) and slide it into the head (1) from the hammer case end.
3. Install Woodruff key (9) onto the drive shaft. Align the keyway in the gear (10) with the Woodruff key on the drive shaft and install the gear onto the drive shaft. Secure the gear with the retaining ring (11).
4. Install the drive pin (12) into the idler shaft (13). Align the keyway in the remaining gear (10) with the drive pin and install the gear onto the idler shaft. Install the idler shaft with gear into the handle, meshing the two gears together. Secure the gear with retaining ring (11).
5. Install dowel pins (14) into handle. Install new O-ring (15) onto motor cap (7) groove.
6. Install motor cap (7) onto head (1). Secure motor cap with cap screws (16). Torque cap screws to 14.3 Nm (130 in-lb). Refer to "Torque Sequence" below.

### Torque Sequence

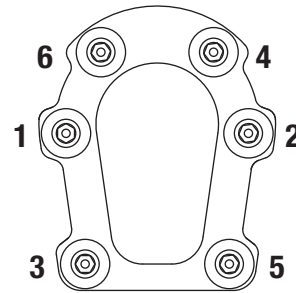

### Trigger, Trigger Spool, and Super Spool

1. Install new O-ring (33) onto Super Spool (30). Install ball (31) in trigger spool (29). Install Super Spool (30) and secure with retaining ring (32).
2. Install new O-ring (64) onto trigger spool (29).
3. Install new O-ring (27) and backup ring (28) into handle (5).  
*Note: Install the backup ring (28) first. Pull the backup ring with a pick so that it is positioned in the groove toward the back side of the tool. Then install the O-ring (27) into the groove in the handle (5).*
4. Slide trigger spool into handle (5) from front end of tool. Spool should bottom out onto handle covers (48, 49).  
*Note: If handle covers (48, 49) are missing or damaged, the trigger spool will need to be dead stopped to prevent it from sliding out of the back when spring (36) is installed.*
5. Slide spring (36) and washer (34) onto spool (29) inside handle (5). Secure spring and washer with retaining ring (35).
6. Install pin (46) into trigger (37) through handle (5). Install second pin (46) through trigger (37) and trigger spool (29). Secure pins with retaining rings (47).

## Assembly (cont'd)

### Reversing Spool

1. Install new O-ring (24) and backup ring (25) onto reversing spool (17).
2. Install new O-ring (27) and backup ring (28) into head (1).
3. Install new O-ring (26) onto plug (20).
4. Screw cap (23) onto spool (17) end closest to O-ring (24).
5. Slide spool (17) into head (1) from the right side.
6. Install poppet (18), spring (19), plug (20), and cap (23) onto the opposite spool end. Use one wrench on each cap (23) and tighten to 31 Nm (23 ft-lb).
7. Install set screw (21) followed by screw (22).
8. Use the Relief Pressure Check Kit shown in the "Accessories" section to check the relief pressure.

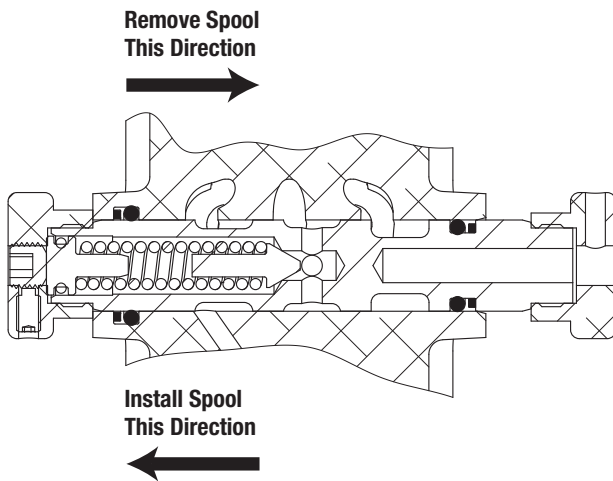

### Hammer Case Components

1. Apply Mobilgrease® HP to thrust bearing (38) and work the grease into needle rollers. Apply a light film of grease to the thrust washers (39). Stack the thrust washers and thrust bearing properly and place the stack onto the drive shaft.
2. Place spacer (40) over the drive shaft with the flange upward.

### Impact Mechanism

1. Apply Mobilgrease HP to the surfaces of the hammer frame (55), hammers (56), hammer pin (57), and anvil (58).
2. Install the two hammers, 180° from each other, into hammer frame. Install pins into hammer frame and through the hammers, then slide the assembly onto the spline of drive shaft.
3. Pack hammer frame center space with Mobilgrease Special #53030-3. Install anvil into hammer frame and through hammers.
4. Install O-ring (43) over threads on hammer case cap (41).
5. Apply Loctite® primer to threads of cap. Apply Loctite primer to threads of handle at cap interface, ensuring threads are free of grease and other contaminants prior to application.
6. Slide the hammer case cap assembly (41, 42) over the anvil and, using a wrench on the flats of the cap, screw the assembly into the handle. Torque to 108 to 115 Nm (80 to 85 ft-lb).

### Quick-Change Chuck

1. Slide thrust ring lock (60) over anvil to the groove closest to hammer case cap.
2. Insert three balls (63) into the holes in the anvil. Slide the retaining sleeve (59) onto anvil with the flanged end upward. Insert spring (62) and thrust ring (61) into retaining sleeve. Slide the thrust ring back and install thrust ring lock (60) onto the anvil.



**Illustration – Main**

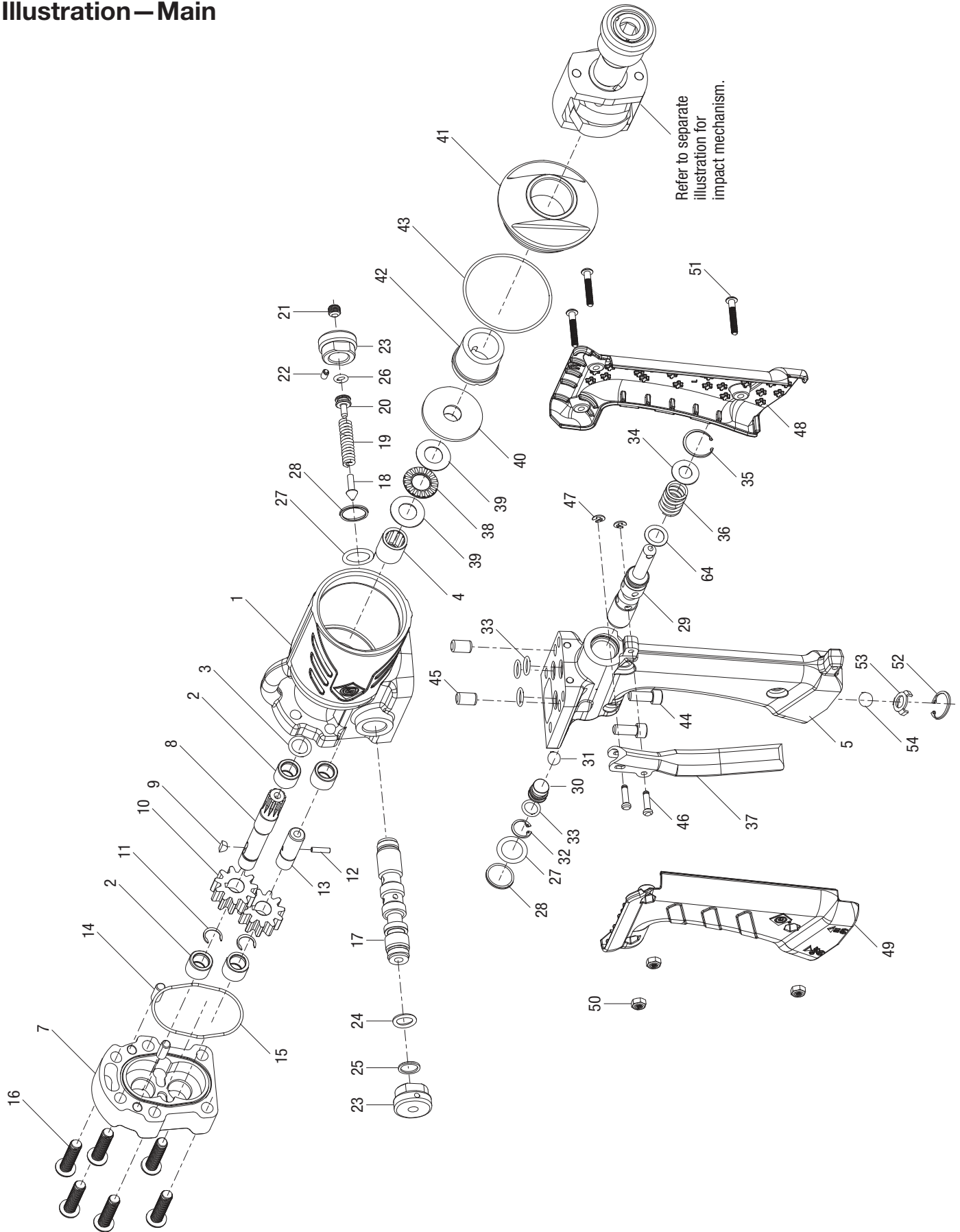

## Illustration – Impact Mechanism

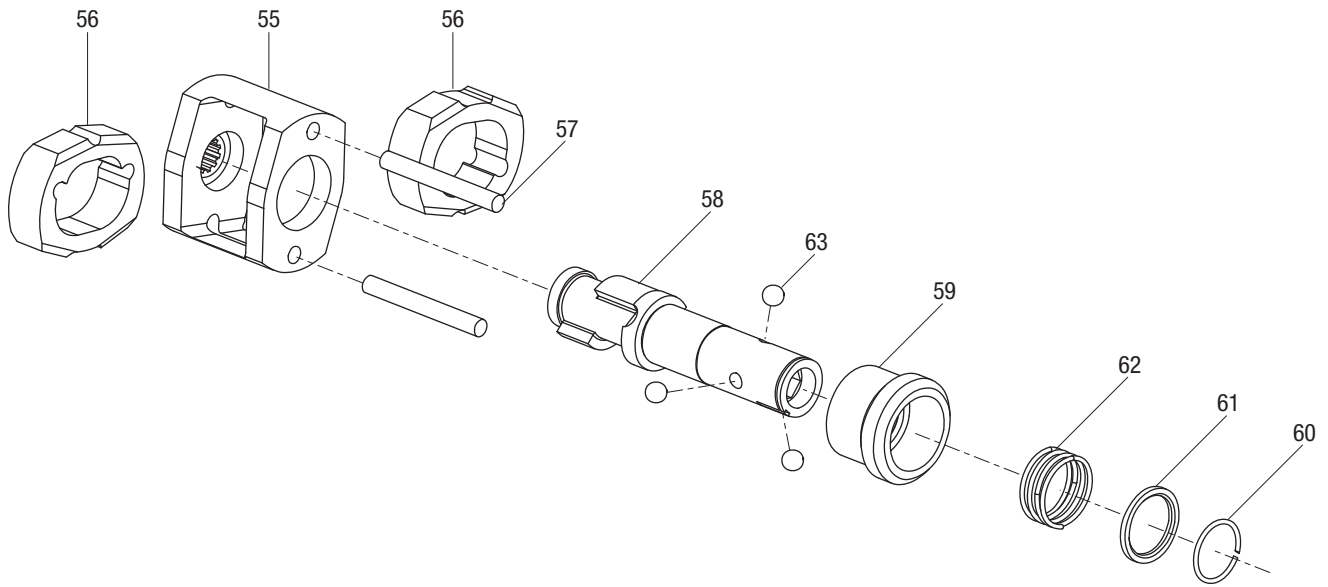

## Parts List

Key	UPC No. 78-3310-	Part No.	Description	Qty
1	00374	52060638	Head assembly (includes items 2-4) ....	1
2	41591	50415911	Bearing, needle, .439 x .625 x .500 .....	4
3*			O-ring, .500 x .687 x .093-80.....	1
4	49243	50492438	Bearing.....	1
5	00378	52060641	Handle assembly .....	1
7	00405	52061528	Motor cap assembly (includes item 2) ..	1
8	49242	50492420	Shaft, drive.....	1
9	41592	50415921	Key, Woodruff, .125 x .375.....	1
10	41630	50416302	Gear, 11 tooth .....	2
11	41621	50416212	Ring, retaining, .437 .....	2
12	41593	50415930	Pin, dowel, .123 x .209 .....	1
13	40168	50401682	Shaft, idler.....	1
14	41624	50416242	Pin, dowel, .250 x .625 .....	2
15*			O-ring, 2.000 x 2.125 x .062 70D .....	1
16			Skt hd cap screw, .3125-18 x 1.25 button, 316 SS.....	6
17	00382	52060645	Spool, directional reversing .....	1
18	48515	50485156	Poppet .....	1
19	48543	50485431	Spring, comp, .177 x .329 x 1.09.....	1
20	48621	50486217	Plug, spec .....	1
21			Screw, skt set, flat point, 5/16-24 x .250.....	1
22			Screw, set, #8-32 x .250 skt brass tip .....	1
23	00404	52061456	Cap, reversing spool.....	2
24*			O-ring, .437 x .625 x .093 70-D nitrile ..	1
25*			Ring, 8-111 Parbak.....	1
26*			O-ring, .250 x .375 x .062-90.....	1
27*			O-ring, .612 x .818 x .103-70.....	2
28*			Ring, 8-114 Parbak.....	2
29	00380	52060643	Spool, directional trigger.....	1
30	48697	50486977	Super Spool.....	1
31	43829	50438298	Ball, steel (.344).....	1
32	48540	50485407	Ring, retaining.....	1
33*			O-ring, .375 x .500 x .062-70.....	4
34	48310	50483102	Washer, flat, .376 x .734 x .03.....	1
35	41648	50416480	Ring, retaining, .750 .....	1
36	00399	52060673	Spring, trigger .....	1
37	00381	52060659	Trigger, impact wrench.....	1
38	48318	50483188	Bearing, thrust .....	1
39	48319	50483196	Washer, thrust .....	2
40	48364	50483641	Spacer.....	1
41	00408	52061531	Cap, hammer case assembly (includes item 42).....	1
42			Bearing.....	1
43*			O-ring, 2.125 x 2.250 x .062-70.....	1
44			Screw, cap, soc hd, 1/4-20 x .625, 316 SS .....	4
45	00388	52060665	Pin, .3125 x .5 dowel .....	2
46	00395	52060651	Pin, trigger impact wrench.....	2
47	42827	50428270	Ring, retaining.....	2
48	00393	52060669	Cover, impact wrench handle, left .....	1
49	00389	52060666	Cover, impact wrench handle, right .....	1
50			8-32 lock nut, .172 thick, nickel-plated .....	3
51			Skt hd cap screw, 8-32 x 1.00 button, 316 SS.....	3
52	41600	50416003	Ring, retaining, .687 .....	1
53	49234	50492349	Stop, ball.....	1
54	50681	90506812	Ball (3/8 dia.).....	1
55			Hammer frame .....	1
56			Hammer .....	2
57			Hammer pin .....	2
58			Anvil, quick-change .....	1
59	49277	50492772	Retaining sleeve.....	1
60	49279	50492799	Thrust ring lock .....	1
61	49280	50492802	Thrust ring .....	1
62	49278	50492780	Sleeve spring .....	1
63	49276	50492764	Ball .....	3
64*			O-ring, .500 x .625 x .062 70-D .....	1
<b>Decals</b>				
	00400	52061451	Decal, F/R, logo .....	1
	00401	52061452	Decal, warning .....	1
<b>Repair Kits</b>				
	00406	52061529	Reversing spool assembly (includes one each of items 16-26 and two of item 23)	
	00607	52062052	Handle cover kit (includes items 48-51)	
	49270	50492705	Impact mechanism assembly (includes items 55-63)	
*	00403	52061455	Seal kit (HW1) (includes all items marked with *)	

**Accessories**

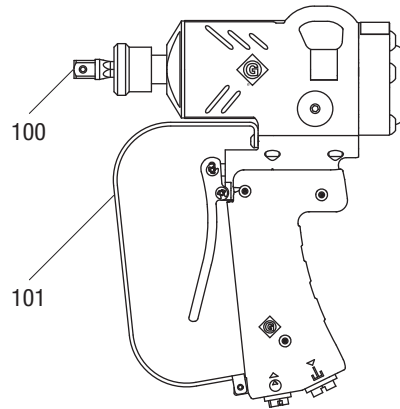

Key	UPC No. 78-3310-	Part No.	Description	Qty
100	49314	50493140	Adapter, heavy-duty, 7/16" quick-change hex to 1/2" square drive.....	1
101	00376	52060640	Trigger guard assembly .....	1
	49004	50490044	Kit, relief pressure check .....	1