

AUDIOACCESS

PX-700

MULTI-ROOM AUDIO CONTROLLER

PRELIMINARY SERVICE MANUAL



Harman Consumer Group
250 Crossways Park Dr.
Woodbury, New York 11797

FEATURES

AUDIOACCESS PX-700 MULTI-ROOM AUDIO CONTROLLER

The Audioaccess PX-700 is a six zone, multi-room, multi-source audio controller that is easily set up with the PX-700 Installation Manager, Audioaccess' proprietary Windows® application.

The award winning PX-700 continues Audioaccess' long tradition of easy to use and easy to install multi-room systems, and adds powerful source control, programming flexibility and customizable features. An all-new audio preamplifier circuit, designed and manufactured by Madrigal Audio Laboratories, delivers the performance associated with high quality, separate audio components.

Together with our elegant, intuitive wall-mounted keypads, touchscreens and handheld remotes, the PX-700 allows direct access and control of eight different audio sources in six separate zones. Each zone can control any five separate sources via the KPS Keypad. All eight sources are accessible from our touchscreen and dedicated remote controls. Alternatively, any source may be dedicated or partitioned for use in a specific zone in the home. Up to six PX-700s can be connected to form a 36 zone system.

The PX-700 is programmed exclusively with the PX-700 Installation Manager, our proprietary Windows® application. A special feature of the software permits adjacent areas, or zones, to be "linked" together so that they track the same source while independent volume control is maintained in each area. With the PX-700 Installation Manager, the installer creates and maintains a comprehensive IR library, which is then used to control all of the source components in an installation. The IR commands only need to be learned once for use in all projects. The PX-700 Installation Manager also allows the installer to define any number of short and long button presses, which can be assigned to the keypads, touchscreens and handheld remotes. Because of the open architecture of the program, multiple high capacity CD Changers or DSS receivers can easily be used in a single installation. IR programming, source assignments, turn-on source defaults, input level matching, group assignments and other programming options may be configured prior to the installation or at the job site. Once completed, the project is downloaded to the PX-700 via an RS-232 input on the rear panel, or a convenient PC Link jack on the front panel of the controller.

The Installation Manager uses standard control features found in all Windows® applications: right mouse clicks, drag and drop, and pop up menus. Diagnostic tools are included to monitor keypad bus communications. Other tools include an Equipment List, Wiring Instructions, Virtual Installation, and a complete on-line Help file.

Features

- Simple, intuitive operation
- Easy installation
- Separate component quality audio performance
- Adjustable input levels for each source
- Independent bass and treble levels for each PX-700 room
- Convenient, expanded programming via PC or laptop
- Create and maintain extensive IR library
- Import/export utilities for merging/updating master library
- Rack mountable chassis
- Eight audio inputs plus a paging input for each zone
- Front panel IR receiver, rear panel IR In/Out jacks
- Built in RS-232 interface accessible from either front or rear panel
- Built-in IR learning device
- Zone linking capabilities
- Any 5 of 8 sources available from KPS keypad in each zone
- Eight sources available from touchscreens and hand-held remotes
- Selectable turn-on source in each zone
- Each zone assignable to one of three ALL ON groups (or none)
- Expandable to 36 zones with additional PX-700 Controllers
- Compatible with PX-603 Multi-Room Expander (add up to 3 rooms per zone)
- Compatible with Audioaccess Multi-Room, 12-channel Amplifiers

Specifications PX-700 Multi-Room Audio Controller

Inputs:

- Eight stereo audio inputs with buffered loop through capability
- One mono page input
- Trigger input allows sharing of audio sources with other systems
- Four-conductor keypad input
- PC Link jack RS-232 interface on front panel
- 9 Pin D-sub RS-232 interface on back panel

Outputs:

- Six room preamp outputs (one per zone)
- Six independent fixed outputs
- One record output from the main zone
- Six programmable 12VDC trigger outputs (one per zone)
- Eight dedicated IR source outputs
- One All IR source output

Audio:

- Connector: Gold Plated RCA Jack
- Input Impedance: 20k ohms
- Maximum Input Level (for 0.1% THD+N at any output): 2.0VRMS
- Output Impedance: 330 ohms
- Maximum Output Level

Source Buffered Outputs: 2.0VRMS

Primary Outputs: 2.75VRMS

Expansion Outputs: 2.0VRMS

- Gain

Source Buffered Outputs: 0 dB (Unity Gain)

Primary Outputs: 18.5 dB (Volume set at 100)

Expansion Outputs: -1 dB

- S/N (Input at 2.2VRMS, 1kHz, Primary Room Volume at Unity Gain, Measurement Bandwidth: 22kHz)

Source Buffered Outputs: >113 dB

Primary Outputs: >95 dB

Expansion Outputs: >100dB

- Frequency Response

Source Buffered Outputs: 10Hz to 110kHz, ± 1 dB

Primary Outputs: 10Hz to 70kHz, ± 1 dB

Expansion Outputs: 10Hz to 75kHz, \pm 1dB

- THD + Noise (Input: 1VRMS, 1kHz, Primary Room Volume at unity gain, measurement Bandwidth: 30kHz)

Source Buffered Outputs: <0.003%

Primary Outputs: <0.006%

Expansion Outputs: <0.005%

- L/R Crosstalk (at 1kHz)

Source Buffered Outputs: <-110 dB

Primary Outputs: <-92 dB

Expansion Outputs: <-104 dB

- Source to Source Crosstalk (at 1kHz, any two sources)

Source Buffered Outputs: <-110 dB

Primary Outputs: <-100 dB

Expansion Outputs: <-105 dB

- Volume Control : 0 to 100dB in 0.5 dB steps (1 dB steps via keypad commands)
- Bass: Shelving Type, \pm 12 dB in 2 dB steps at 100Hz
- Treble: Shelving Type, \pm 12 dB in 2 dB steps at 10kHz

Trigger Input and Outputs:

- Connector: 3.5mm Mini Phone Jack
- Trigger Out and Zone Trigger Output Voltage: 8 to 16VDC (depending on line voltage and load), Tip Positive
- Page Trigger In: Dry Contact
- Trigger In: 4 to 30VDC, Tip Positive; 3 to 24VRMS AC

Power Inlet:

- Connector: Male IEC320
- Power Requirement: 115V AC, 50/60Hz, 50 Watts (not including switched outlet)*

Switched Outlet:

- Connector: NEMA 5-15R*
- Maximum Load: 300 Watts

Dimensions

- 17.3" (440mm)W x 4" (102mm)H x 15.5" (394mm)D. Includes Connectors and Feet

Weight

- 11.5 lb (5kg)

*120V Version. 230V Version Power Requirement is 230V AC. 50/60Hz. 50 Watts: Switched Outlet Connector is Female

PX-700 PRODUCT DESCRIPTION

Description

The PX-700 Multi-Room Controller is a six zone, multi-room, multi-source audio system controller that is easily set up with the PX-700 Installation Manager, Audioaccess' proprietary Windows® application.

Designed and manufactured by Madrigal Audio Laboratories, the audio section delivers the performance associated with high-quality, separate audio components. The PX-700 chassis fits standard rack-mount shelves or rack mounts directly with the optional Rack Mount Kit.

Together with wall-mounted keypads and handheld remotes, the PX-700 allows direct access and control of eight different audio sources in six separate zones. Each zone can control any five separate sources via the KPS Keypad. All eight sources are accessible from a dedicated remote control. Up to six PX-700s can be connected to form a 36-zone installation. Link an unused zone to another zone to add rooms (without using a PX-603 Room Expander) or link multiple zones to create a zone with more than four rooms (using PX-603s).

The PX-700 is programmed exclusively with the PX-700 Installation Manager, a proprietary Windows® application. With the PX-700 Installation Manager, the installer creates and maintains a comprehensive IR Library, which is then used to configure control over the source components in an installation. The IR codes only need to be learned once for use in all projects. The Installation Manager also allows the installer to define any number of short and long button presses, which can be assigned to both the keypads and remotes. Any number of IR commands can be sent with each press. Because of the open architecture of the program, multiple high-capacity CD Changers or DSS receivers can easily be used in a single installation. IR programming, source assignments, turn-on source defaults, input level matching, group assignments and other programming options may be configured prior to the physical installation or at the job site. Once completed, the project is downloaded to the PX-700 via an RS-232 input on the rear panel or a convenient PC Link Jack on the front panel of the controller.

The Installation Manager uses standard control features found in all Windows applications: right mouse clicks, drag and drop, and pop up menus. Diagnostic tools are included to monitor keypad bus communications. Other tools include an Equipment List, Wiring Instructions, and a complete on-line Help file.

Features

- Simple, intuitive operation, installation and programming
- Component-quality audio performance
- Convenient programming via PC or laptop
- Built in RS-232 interface accessible from either front or rear panel
- Create and maintain an extensive IR Library
- Import/export utilities for merging/updating master IR Library
- Eight audio inputs plus a paging input for each Zone
- Eight sources available from hand-held remotes
- Any 5 of 8 sources available from Audioaccess keypads in each Zone
- Selectable turn-on source in each Zone
- Built-in IR learning device
- Zone linking capabilities
- Each Zone assignable to one of three All On groups (or none)
- Adjustable input levels for each source
- Front panel IR receiver, rear panel IR In/Out jacks
- Independent bass and treble levels for each PX-700 Room
- Expandable to 36 Zones with additional PX-700 Controllers
- Rack Mount Kit option (available separately)

Inputs

- Eight stereo audio inputs with buffered outputs
- One mono page input
- Trigger input that allows sharing of audio sources with other systems
- Four-conductor keypad input
- PC Link jack RS-232 interface on front panel
- 9 Pin D-sub RS-232 interface on rear panel
- Rear panel IR input

Outputs

- Six buffered preamp outputs (one per zone)
- Six fixed outputs
- Zone Six record output
- Six programmable 12VDC trigger outputs (one per zone)
- Nine infrared emitter jacks (one per audio source and blaster)
- Trigger output
- Rear panel IR output

Front Panel

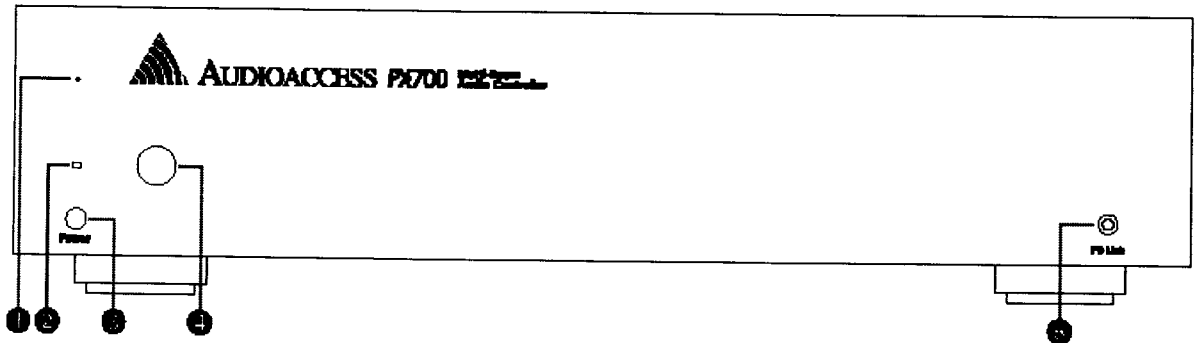

1. **SYSTEM CODE SWITCH** (Momentary switch accessible through panel)
2. **LED** (Bi-color: red when power is applied, green when any zone is on)

The front panel LED on the PX-700 indicates that the unit has power and that at least one Zone is on in the System. If the LED is on (in any color), the unit is powered. If the LED is red, no Zones are on in that System. If the LED is green, at least one Zone is on in the System. The LED sequence at power on is as follows: when you apply power to the PX-700 the LED will be red. After completing the power-on sequence (about 6 seconds), the LED will turn green for approximately 5 seconds, then back to red. This indicates that the PX-700 is ready for operation or programming.

3. **AC POWER SWITCH** (Push button switch)

The PX-700 front panel power switch is used to turn on and off the main power to the unit. With the PX-700 plugged into an outlet, when the switch is in the in position, power is applied to the unit. When the switch is in the out position, power is not applied to the unit. The power state can be determined by looking at the front panel LED.

4. **IR WINDOW** (Receives IR commands, controls Zone 6, active only on System 1)
5. **THE FRONT PANEL POWER SWITCH DISCONNECTS ONLY THE LINE SIDE OF THE AC SUPPLY WHEN IT IS IN THE OFF POSITION. TO COMPLETELY DISCONNECT THE UNIT FROM THE AC SUPPLY, THE POWER CORD MUST BE UNPLUGGED FROM EITHER THE UNIT OR THE OUTLET.**
6. **PC LINK JACK** (mono 1/8" / 3.5mm mini-phone jack)

Rear Panel

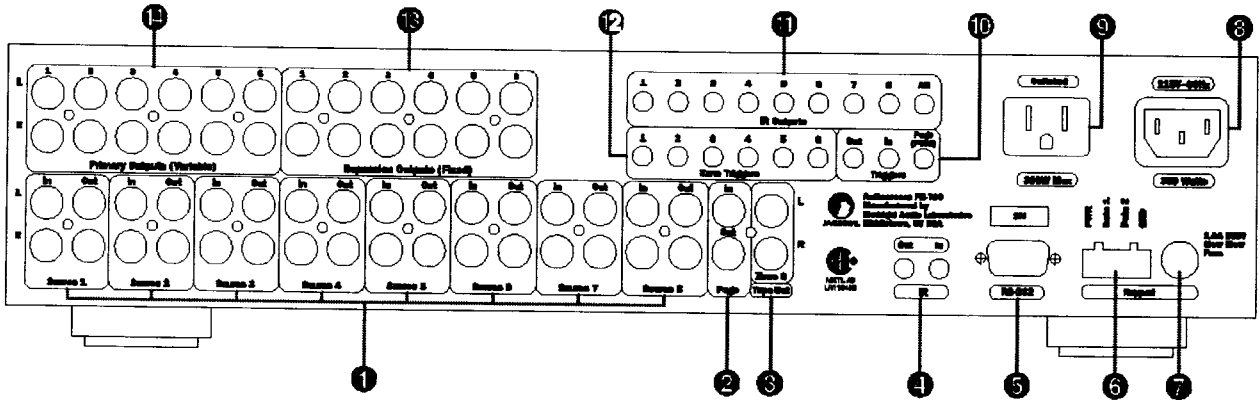

1. **SOURCE CONNECTIONS** (*RCA connectors*)
2. **PAGE IN/OUT** (*RCA connectors*)
For use with PDM to work with paging systems.
3. **ZONE 6 TAPE OUT** (*RCA connectors*)
4. **IR IN/OUT** (*mono 1/8" / 3.5mm mini-phone jacks*)
5. **RS-232 PORT** (*9-pin female connector*)
6. **KEYPAD** (*4-conductor plug with screw terminals*)
7. **FUSE**
US: 5x20mm, 1.6amp, 250v, slow blow *NON-US: 5x20mm T 1.6amp 250v*
8. **POWER INPUT** (*3-conductor, IEC type*)
9. **SWITCHED OUTLET** (*3-conductor grounded, 300Watt maximum*)
10. **TRIGGERS** (*mono 1/8" / 3.5mm mini-phone jacks*)
11. **IR OUTPUTS** (*mono 1/8" / 3.5mm mini-phone jacks*)
12. **ZONE TRIGGERS** (*mono 1/8" / 3.5mm mini-phone jacks*)
13. **EXPANSION OUTPUTS** (*Fixed*) (*RCA connectors*)
14. **PRIMARY OUTPUTS** (*Variable*) (*RCA connectors*)

TECHNICAL SPECIFICATIONS

Specifications

Note: Due to constant research, specifications are subject to change without notice.

Audio

- Connector: Gold Plated RCA Jack
- Input Impedance: 20k Ω
- Maximum Input Level (for 0.1% THD+N at any output): 2.0VRMS
- Output Impedance: 330 Ω

Specification	Source Buffered Outputs	Primary Outputs	Expansion Outputs
<i>Frequency Response</i>	10HZ to 110kHz, \pm 1dB	10HZ to 70kHz, \pm 1dB	10HZ to 70kHz, \pm 1dB
<i>S/N (Input at 2.2VRMS, 1kHz, Primary Room Volume at Unity Gain, Measurement Bandwidth: 22kHz)</i>	>113 dB	>95 dB	>100 dB
<i>THD + Noise (Input: 1VRMS, 1kHz, Primary Room Volume at unity gain, Measurement Bandwidth: 30kHz)</i>	<0.003%	<0.006%	<0.005%
<i>Maximum Output Level</i>	2.0 VRMS	2.75 VRMS	2.0 VRMS
<i>Left/Right Crosstalk (@ 1k Hz, each input)</i>	<-110 dB	<-92 dB	<-104 dB
<i>Source to source Crosstalk (@ 1k Hz any two sources)</i>	<-110 dB	<-100 dB	<-105 dB
<i>Zone to Zone Crosstalk (@ 1k Hz, any two zones)</i>		<-100 dB	<-100 dB
<i>Maximum Gain</i>	Unity	18.5 dB (Volume set at 100)	-1 dB
<i>Volume Control</i>		0 to 100 dB in 0.5 dB steps	
<i>Bass (Shelving type, 100 Hz)</i>		+12, -12 dB (2 dB steps)	N/A
<i>Treble (Shelving Type, 10k Hz)</i>		+12, -12 dB (2 dB steps)	N/A

Trigger Input and Outputs Connector:

3.5mm Mini Phone Jack

Trigger Input

- Connector: 3.5mm Mini Phone Jack **and Outputs** Trigger Out and Zone Trigger Output Voltage: 8 to 16 VDC (depending on line voltage and load), Tip Positive
- Page Trigger In: Dry Contact
- Trigger in: 4 to 30 VDC, Tip Positive; 3 to 24 VRMS AC

PX-700

Electrical/Mechanical Parts Lists

Note:

These parts lists may contain some part numbers that are not valid, or No Longer Available.

Descriptions and Reference Designators, when included, should aid technicians in part substitution.

If necessary, call the Parts department at 1-516-496-3400 ext. 6553 for assistance.

PX-700 TRIGGER OUTPUT BD



AUDIOACCESS *PX-700 Parts List*

804-00065-00, ASSEMBLY, PX700 TRIGGER OUTPUT BOARD

Item	qty	Reference	PN	Description
100	9	J1,J2,J3,J4,J5,J6,J7,J8,J9	321-20000-00	PHONE JACK, 3.5mm, MONO, SB
180	1	U1	230-30004-00	INVERTER, HEX, 74HC04, SOIC14
190	2	U2,U3	271-30211-00	OPTOISOLATOR, MOC211, SOIC8
170	9	R2,R5,R8,R13,R14,R18,R22,R26,R30	122-32100-00	RES, SMT, 1K, 5%, TF, 1/8W, 0805
160	23	R1,R3,R4,R6,R7,R9,R10,R11,R12,R15,R16,R17,R19,R20,R21,R23,R24,R25,R27,R28,R29,R31,R32	122-33100-00	RES, SMT, 10K, 5%, TF, 1/8W, 0805
150	1	RV1	381-00020-00	PTC, 0.20amp
140	7	Q2,Q4,Q6,Q8,Q10,Q12,Q14	210-53904-00	TRANS, NPN, SMT, MMBT3904LT1, SOT23
130	7	Q1,Q3,Q5,Q7,Q9,Q11,Q13	211-53906-00	TRANS, NPN, SMT, MMBT3906LT1, SOT23
120	2	M1,M2	612-18190-00	BRACKET, PC MNT SCREW TERM, 8190 (NO SCRE
110	1	J10	320-55107-00	HEADER, 2X7, RA, SHROUDED
10	1		054-00065-00	SCHEMATIC, PX700 TRIGGER OUTPUT BOARD
80	2	C13,C12	150-32310-00	CAP, SMT AL EL, 10uF, 25V, 20%
70	1	C4	150-42310-00	CAP, SMT AL EL, 10uF, 35V, 20%
60	11	C1,C2,C3,C5,C6,C7,C8,C9,C10,C11,C14	155-21410-01	CAP, SMT CER, 0.1uF, 50V, X7R 10%, 0805
50	1		094-00065-00	FAB DRAWING, PX700 TRIGGER OUTPUT BOARD
40	1		404-00065-00	PCB, PX700 TRIGGER OUTPUT BOARD
30	1		044-00065-00	ASSEMBLY DRAWING, PX700 TRIGGER OUTPUT B
20	1		074-00065-00	PARTS PLACEMENT DIAGRAM, PX700 TRIGGER O
90	8	D1,D2,D3,D4,D5,D6,D7,D8	200-60S1D-00	DIODE, RECT, SMT, 1A/140VRMS, S1D

AC TRIGGER IN

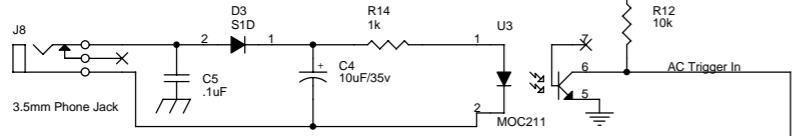

PAGE TRIGGER IN

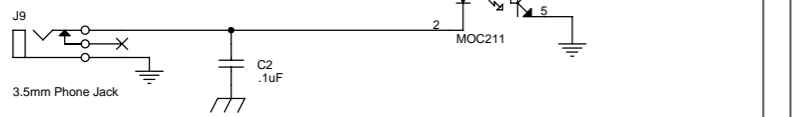

Note: C14 is the bypass cap for U1. C11 and C12 bypass +5v as it enters the board.

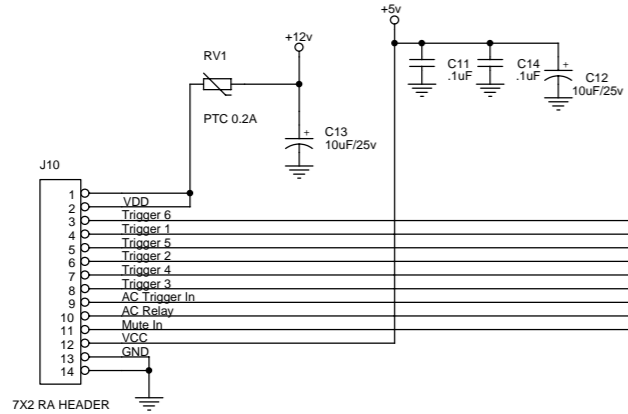

M1

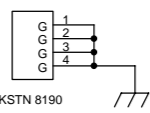

M2

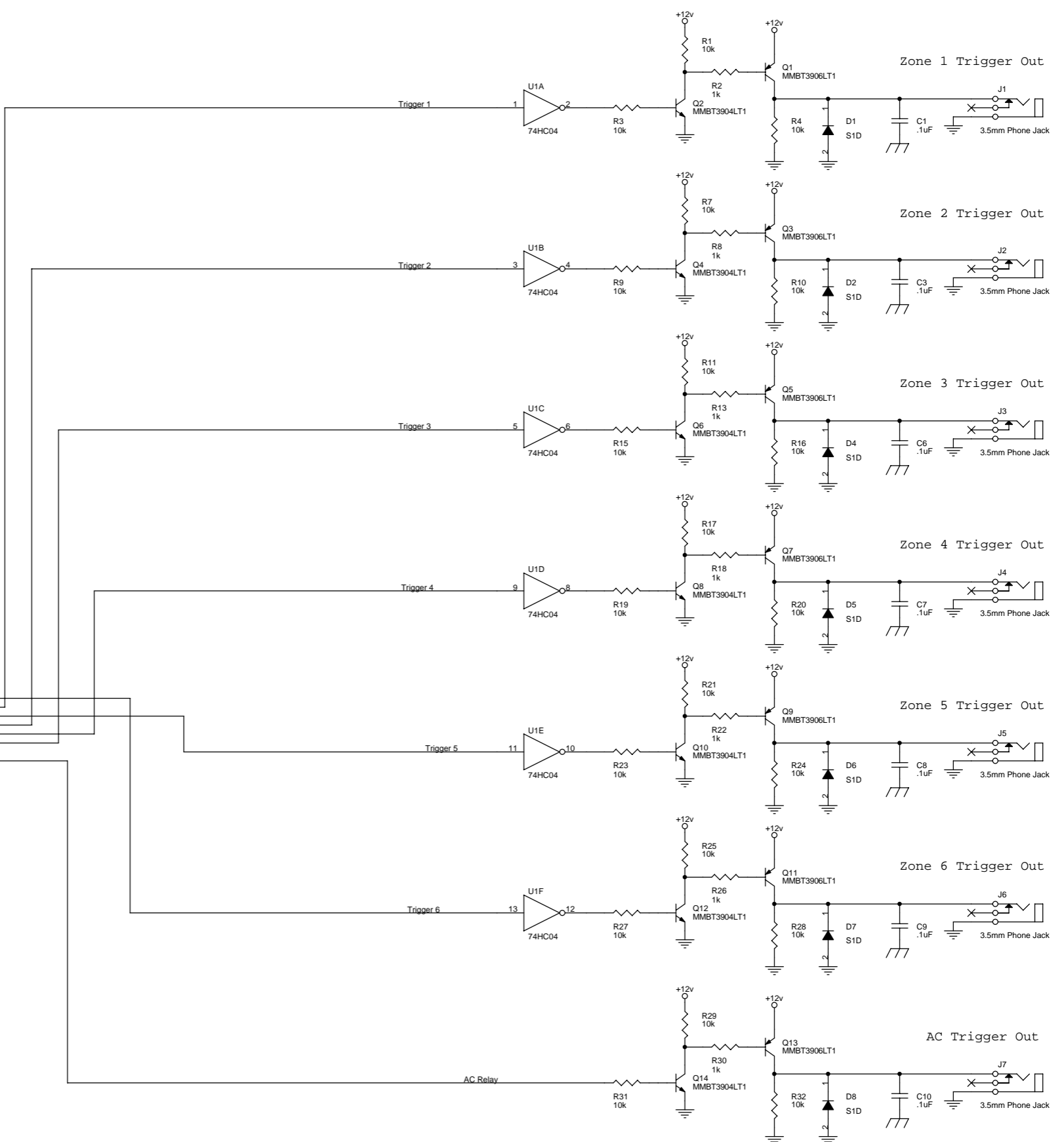
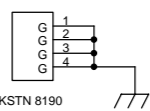

PX-700 RS-232 INPUT BD



AUDIOACCESS *PX-700 Parts List*

80A-00065-00, ASSEMBLY, PX700 RS232 INPUT BOARD

Item	qty	Reference	PN	Description
10	1		05A-00065-00	SCHEMATIC, PX700 RS232 INPUT BOARD
20	1		07A-00065-00	PARTS PLACEMENT DIAGRAM, PX700 RS232 INPU
40	1		40A-00065-00	PCB, PX700 RS232 INPUT BOARD
50	1		09A-00065-00	FAB DRAWING, PX700 RS232 INPUT BOARD
70	1	J2	320-56005-00	HEADER, 1X5, ST, POL, SHROUDED, 2mm
30	1		04A-00065-00	ASSEMBLY DRAWING, PX700 RS232 INPUT BOARD
60	1	J1	321-21000-00	PHONE JACK, 3.5mm, STEREO, SB, NO THREAD

A

B

C

D

E

4

4

3

3

2

2

1

1

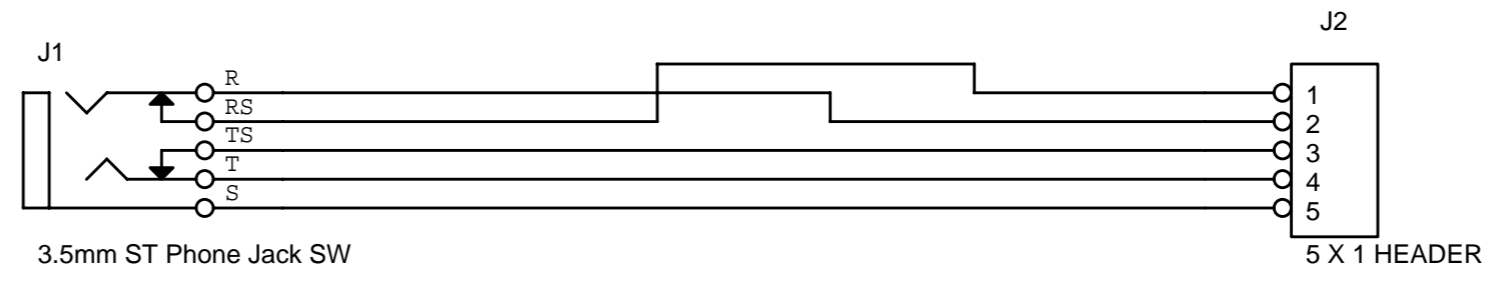

Title		
PX-700 RS-232 Input Board		
Size	Document Number	Rev
A	051-00065	00
Date:	Friday, April 21, 2000	Sheet 1 of 1

A

B

C

D

E

PX-700 CONTROLLER BD

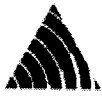

AUDIOACCESS *PX-700 Parts List*

802-00065-00, ASSEMBLY, PX700 CONTROLLER BOARD

item	qty	Reference	PN	Description
240	1	J11	320-56010-00	HEADER, 1X10, ST, POL, SHROUDED, 2mm
160	1	F1	690-01000-00	FUSE HOLDER, 5X20mm PC MNT, BAYONET
170	1	J1	320-55010-00	HEADER, 2X10, SHROUDED
180	2	J2,J4	321-20000-00	PHONE JACK, 3.5mm, MONO, SB
190	1	J3	320-55013-00	HEADER, 2X13, ST, SHROUDED
200	1	J5	323-00004-00	CONN, TERM BLK, PLG, PCRA, 4 PIN
210	1	J6	320-55007-00	HEADER, 2X7, ST, SHROUDED
250	1	J12	320-52003-00	HEADER, 1X3
230	1	J8	320-52204-00	HEADER, 1X4, ST, POL, LOCKRAMP
150	5	FL1,FL2,FL3,FL4,FL5	190-60310-00	EMI FILTER, SMT, 10000pF
260	1	K1	308-00005-00	RELAY, PCNPSS, 2 FORM C, 5V
100	1	C7	150-32310-00	CAP, SMT AL EL, 10uF, 25V, 20%
220	1	J7	320-55005-00	HEADER, 2X5, SHROUDED
140	1	D6	201-54148-00	DIODE, SWITCHING, SMT, MMBD4148
130	2	D5,D4	205-70050-00	DIODE, TVS, 600W, UNI-DIR, 5.0V, SMT
120	1	D3	205-70200-00	DIODE, TVS, 600W, UNI-DIR, 20V, SMT
10	1		052-00065-00	SCHEMATIC, PX700 CONTROLLER BOARD
20	1		072-00065-00	PARTS PLACEMENT DIAGRAM, PX700 CONTROLLE
30	1		042-00065-00	ASSEMBLY DRAWING, PX700 CONTROLLER BOAR
40	1		402-00065-00	PCB, PX700 CONTROLLER BOARD
50	1		092-00065-00	FAB DRAWING, PX700 CONTROLLER BOARD
60	2	C1,C27	150-22347-00	CAP, SMT AL EL, 47uF, 16V, 20%
70	21	C2,C3,C8,C9,C10,C11,C12, C13,C14,C15,C16,C17,C18, C19,C20,C21,C22,C23,C24, C25,C28	155-21410-01	CAP, SMT CER, 0.1uF, 50V, X7R 10%, 0805



AUDIOACCESS **PX-700 Parts List**

802-00065-00, ASSEMBLY, PX700 CONTROLLER BOARD

Item	qty	Reference	PN	Description
90	2	C6,C26	155-20147-00	CAP, SMT CER, 470pF, 50V, COG 5%, 0805
330	2	R3,R10	122-34100-00	RES, SMT, 100K, 5%, TF, 1/8W, 0805
80	2	C5,C4	155-20018-00	CAP, SMT CER, 18pF, 50V, COG 5%, 0805
440	2	U8,U10	230-30138-00	DECODER, 3 TO 8, 74HC138, SMT
300	2	Q2,Q3	210-53904-00	TRANS, NPN, SMT, MMBT3904LT1, SOT23
310	1	R1	122-33150-00	RES, SMT, 15K, 5%, TF, 1/8W, 0805
320	1	R2	122-32330-00	RES, SMT, 3.3K, 5%, TF, 1/8W, 0805
340	7	R4,R11,R12,R17,R18,R19, R20	122-33100-00	RES, SMT, 10K, 5%, TF, 1/8W, 0805
110	2	D1,D2	200-60S1D-00	DIODE, RECT, SMT, 1A/140VRMS, S1D
360	2	R16,R14	122-32150-00	RES, SMT, 1.5K, 5%, TF, 1/8W, 0805
370	1	R15	122-31120-00	RES, SMT, 120, 5%, TF, 1/8W, 0805
380	1	U1	254-40707-00	RESET IC, MAX707, SMT
390	1	U2	250-10552-00	MICROPROC, 80C552, 16MHz, PLCC68
400	1	U3	230-30573-00	LATCH, OCTAL, TRI STATE, 74HC573, SMT
410	1	U5	260-03012-00	SRAM, NON VOLATILE, DS1230Y-120
350	6	R5,R6,R7,R8,R9,R13	122-32100-00	RES, SMT, 1K, 5%, TF, 1/8W, 0805
430	1	U7	230-30000-00	NAND GATE, QUAD, 2 IN, 74HC00, SMT
290	1	Q1	211-53906-00	TRANS, NPN, SMT, MMBT3906LT1, SOT23
450	2	U9,U16	230-30014-00	SCHMIDT TRIGGER, INVERTING, HEX, 74HC14, SM
460	1	U11	230-30245-00	BUS TRANCVR, OCTAL, NON INV, TRI STATE, 74HC
470	2	U14,U12	270-00485-00	INTRFC, BUS TRANS, RS485, LTC485
480	1	U13	270-32321-00	INTRFC, BUS TRANS, DUAL RS232, MAX232A, SMT
490	1	U15	271-30211-00	OPTOISOLATOR, MOC211, SOIC8
500	1	Y1	345-11059-00	XTAL, HC49, 11.0592MHz
510	1	U5	328-02028-00	SOCKET, 0.600" DIP DLTST, 28 PIN



AUDIOACCESS *PX-700 Parts List*

802-00065-00, ASSEMBLY, PX700 CONTROLLER BOARD

item	qty	Reference	PN	Description
520	1	U4	328-02032-00	SOCKET, 0.600" DIP DLTST, 32 PIN
530	1	U2	328-10168-00	SOCKET, PLCC, TSM, 68 PIN
540	2	U12, U14	328-00008-00	SOCKET, 0.300" DIP DLTST, 8 PIN
280	1	P1	327-01009-00	CONN, DSUB, RA, RECEP, 9 PIN
270	2	M1,M2	612-18190-00	BRACKET, PC MNT SCREW TERM, 8190 (NO SCRE
420	1	U6	230-30541-00	BUFFER, OCTAL, TRI STATE, 74HC541, SMT

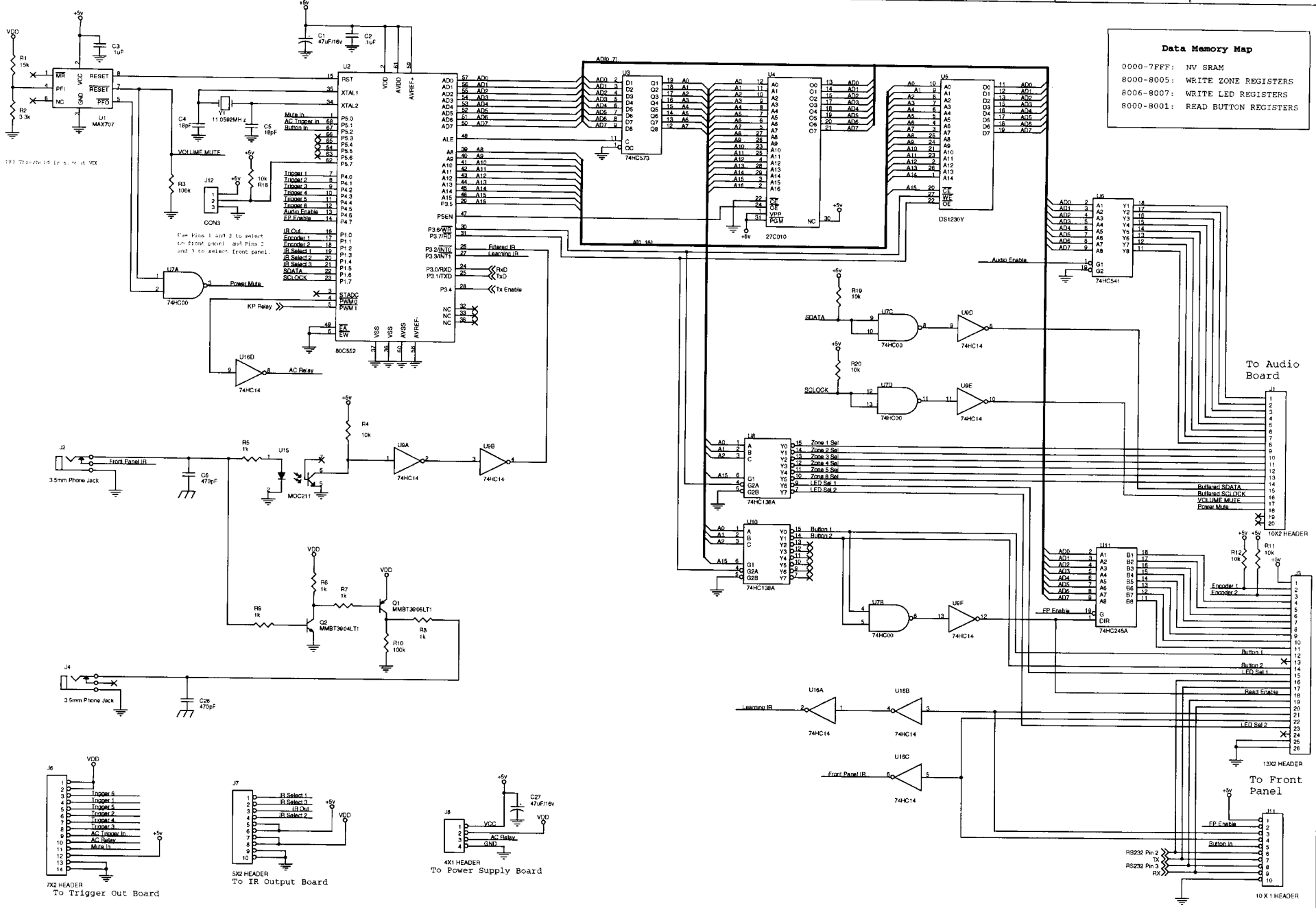

Data Memory Map	
0000-7FFF:	NV SRAM
8000-8005:	WRITE ZONE REGISTERS
8006-8007:	WRITE LED REGISTERS
8000-8001:	READ BUTTON REGISTERS

Data Memory Map

0000-7FFF:	NV SRAM
8000-8005:	WRITE ZONE REGISTERS
8006-8007:	WRITE LED REGISTERS
8000-8001:	READ BUTTON REGISTERS

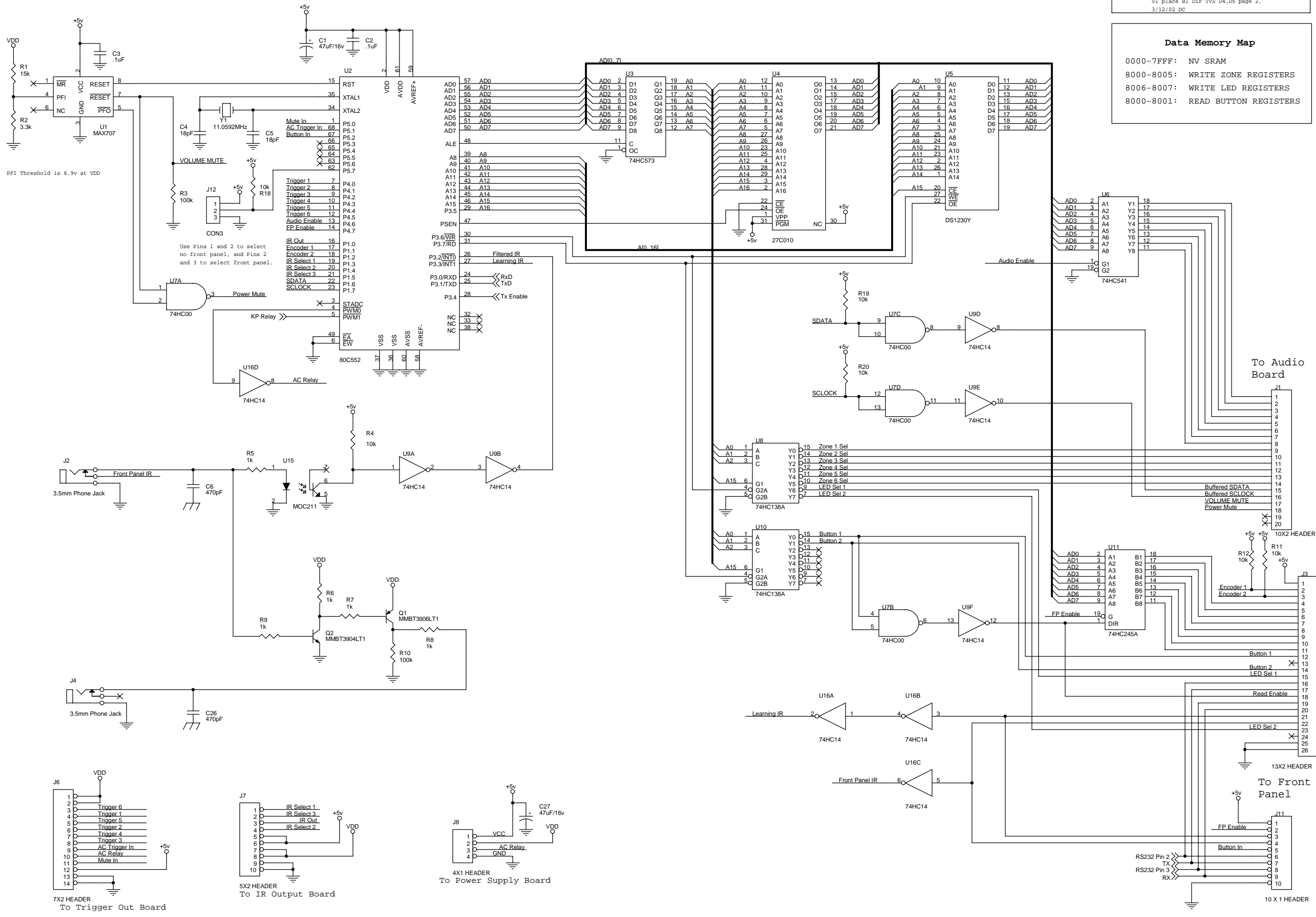

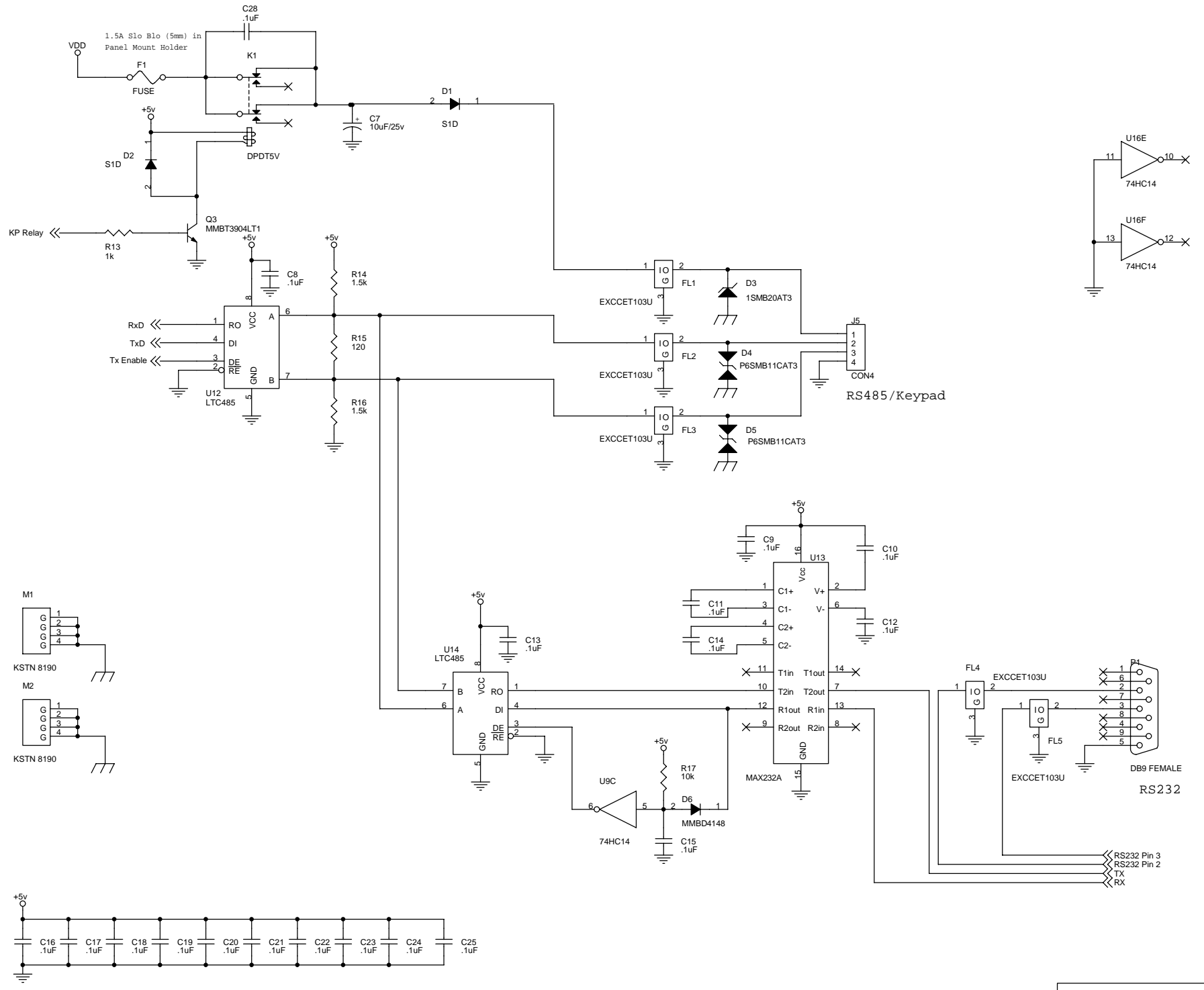

Title		
PX-700 Controller Board		
Size	Document Number	Rev
C	052-00065	02
Date:	Friday, September 20, 2002	Sheet 2 of 2

PX-700 POWER SUPPLY BD



AUDIOACCESS *PX-700 Parts List*

805-00066-00, ASSEMBLY, PX700 POWER SUPPLY BOARD, 120V

Item	qty	Reference	PN	Description
60	8	C3,C5,C7,C9,C11,C13,C15, C16	135-22410-00	CAP, AX CER, 0.1uF 50V, Z5U 20%
220	1	R1	101-12100-00	RES, AXIAL, 1.0K, 5%, CF, 1/8W
40	1		405-00065-00	PCB, PX700 POWER SUPPLY BOARD
130	1	J1	320-52208-00	HEADER, 1X8, ST, POL, LOCKRAMP
140	1	J2	320-52204-00	HEADER, 1X4, ST, POL, LOCKRAMP
150	1	J6	320-52605-00	HEADER, 1X5, ST, POL, LOCKRAMP, 0.156"
160	5	J4,J5,J7,J8,J9	324-01021-00	CONN, QC PC MALE, 0.250"
170	1	J3	320-52205-00	HEADER, 1X5, ST, POL, LOCKRAMP
180	1	K1	308-15012-00	RELAY, PC NPSS TYPE 1, 12V
190	2	JP1, JP3	101-10000-00	JUMPER, 0.300"
110	1	D3	200-14003-00	DIODE, RECT, 1A, 1N4003
210	2	RV1	191-04250-00	MOV, RAD DISC,14mm, 250V
100	2	D1,D2	203-34005-00	BRIDGE RECT, 4A, 50V
230	1	R2	101-30470-00	RES, AXIAL, 47 Ohm, 5%, CF, 1/4W
240	2	U1,U5	220-27805-00	VREG, TO-220 IN, +5V, 7805
250	1	U2	220-27806-00	VREG, TO-200 IN, +6V, 7806
260	1	U3	220-27905-00	VREG, TO-220 IN, -5V, 7905
270	1	U4	220-27906-00	VREG, TO-220 IN, -6V, 7906
280	10	U1, U2, U3, U4, U5	700-06021-00	HEATSINK, TO-220, 6021
290	5	U1, U2, U3, U4, U5	600-10003-00	SCREW, MCH PH PN ZNC, 4-40X0.375"
300	5	U1, U2, U3, U4, U5	610-10100-00	NUT, 4-40, KEP
310	1	U5	750-20058-00	HEATSINK PAD, TO-220 (SILPAD)
200	1	Q1	210-03904-00	TRANS, NPN, 2N3904
90	1	C17	140-32547-00	CAP, RAD AL EL, 4700uF, 25V, 20%
80	2	C4,C10	140-22547-00	CAP, RAD AL EL, 4700uF, 16V, 20%



AUDIOACCESS **PX-700 Parts List**

805-00066-00, ASSEMBLY, PX700 POWER SUPPLY BOARD, 120V

Item	Qty	Reference	PN	Description
70	5	C2,C6,C8,C12,C18	140-32347-00	CAP, RAD AL EL, 47uF, 25V, 20%
50	1		095-00065-00	FAB DRAWING, PX700 POWER SUPPLY BOARD
30	1		045-00065-00	ASSEMBLY DRAWING, PX700 POWER SUPPLY BOA
20	1		075-00065-00	PARTS PLACEMENT DIAGRAM, PX700 POWER SUP
10	1		055-00065-00	SCHEMATIC, PX700 POWER SUPPLY BOARD
120	4	F1,F2	690-00501-00	FUSE CLIP, 5mm PC MNT, 111-501

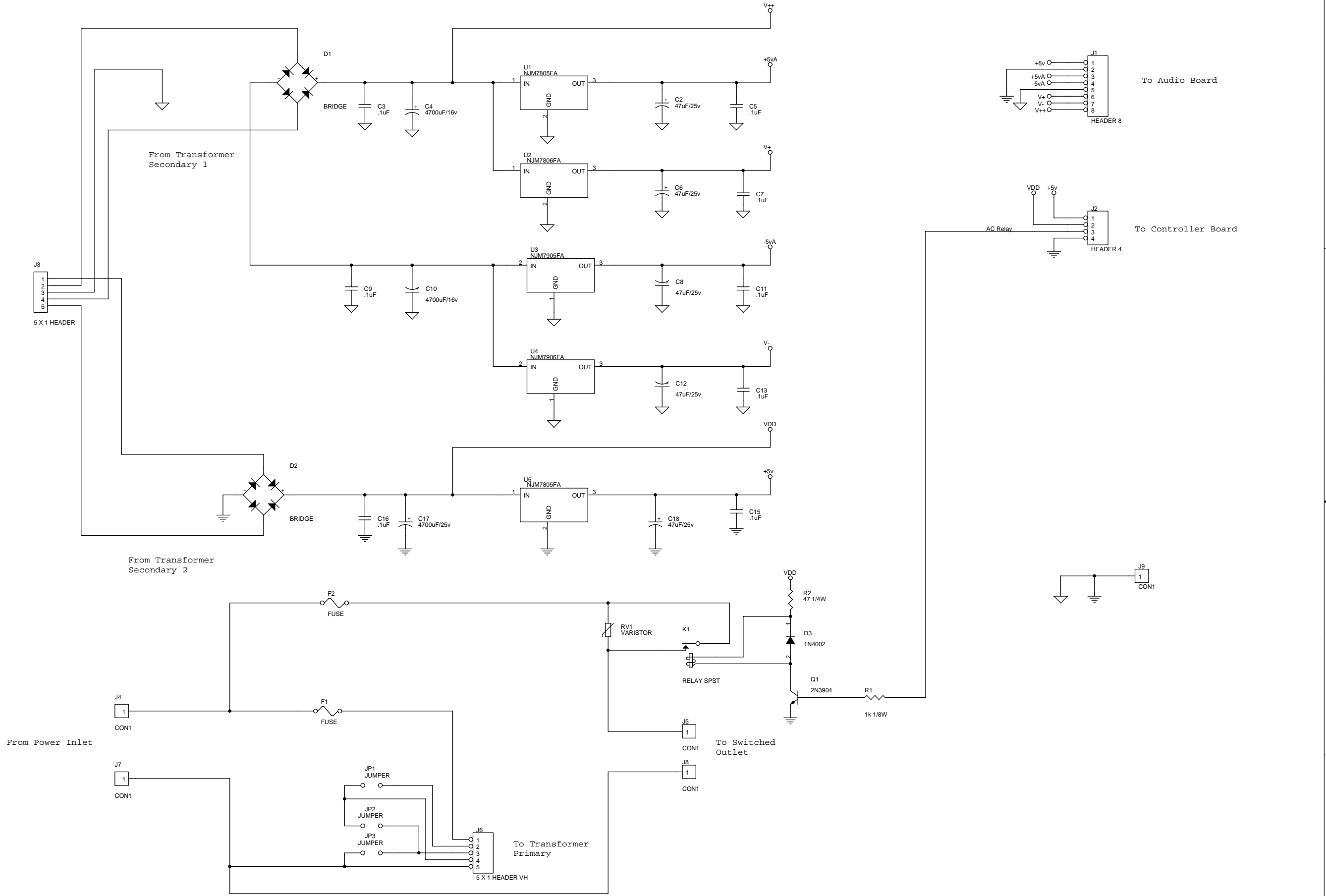

Install JP1 and JP3 only for 115V.
 Install JP2 only for 230V.

Title		
PX-700 Power Supply Board		
Size	Document Number	Rev
C	055-00065	00
Date:	Friday, April 21, 2000	Sheet 1 of 1

PX-700 Audio Output BD

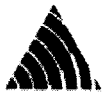

AUDIOACCESS **PX-700 Parts List**

801-00065-00, ASSEMBLY, PX700 AUDIO OUTPUT BOARD

item	qty	Reference	PN	Description
100	4	J7,J8,J9,J10	460-00065-00	RIBBON CABLE, 10.25", 12 CONDUCTOR
90	4	J7,J8,J9,J10	320-00012-00	RIBBON HOLDER, 2mm, 12 COND
80	6	J1,J2,J3,J4,J5,J6	321-02001-00	RCA JACK, 14mm QUAD, R/W
70	12	C4,C5,C6,C13,C14,C15,C22,C23,C24,C31,C32,C33	155-21410-01	CAP, SMT CER, 0.1uF, 50V, X7R 10%, 0805
60	24	C1,C2,C3,C7,C8,C9,C10,C11,C12,C16,C17,C18,C19,C20,C21,C25,C26,C27,C28,C29,C30,C34,C35,C36	155-20210-00	CAP, SMT CER, 0.001uF, 50V, COG 5%, 0805
50	1		091-00065-00	FAB DRAWING, PX700 AUDIO OUTPUT BOARD
40	1		401-00065-00	PCB, PX700 AUDIO OUTPUT BOARD
30	1		041-00065-00	ASSEMBLY DRAWING, PX700 AUDIO OUTPUT BOA
10	1		051-00065-00	SCHEMATIC, PX700 AUDIO OUTPUT BOARD
110	2	M1,M2	612-18190-00	BRACKET, PC MNT SCREW TERM, 8190 (NO SCRE
20	1		071-00065-00	PARTS PLACEMENT DIAGRAM, PX700 AUDIO OUTP

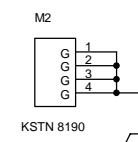
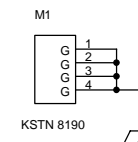
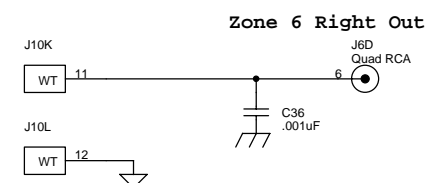
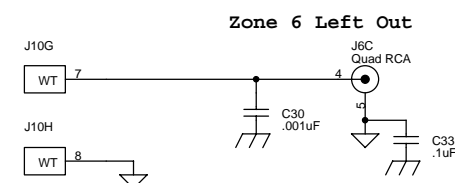
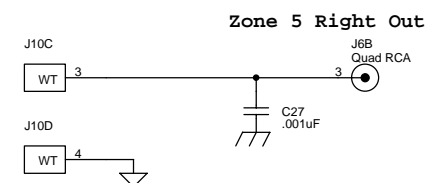
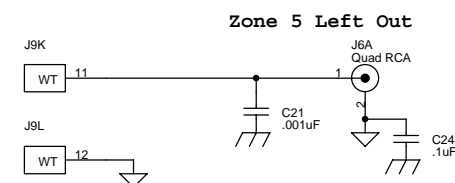
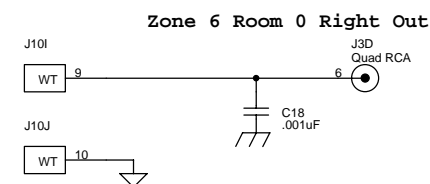
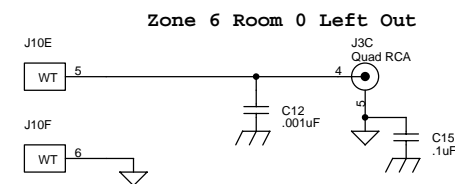
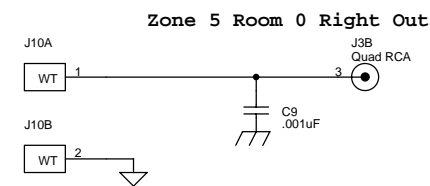
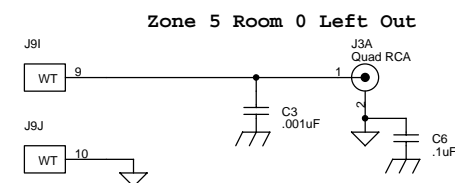
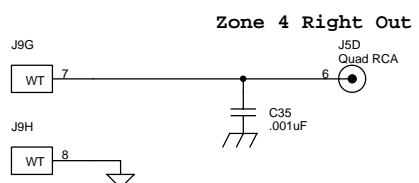
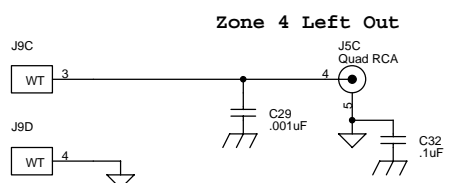
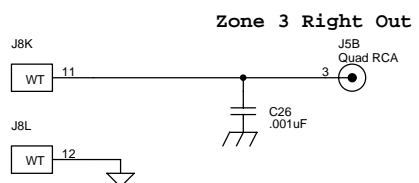
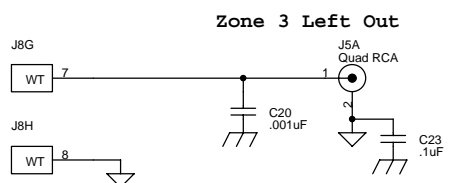
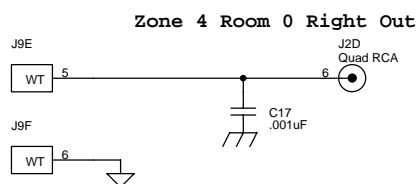
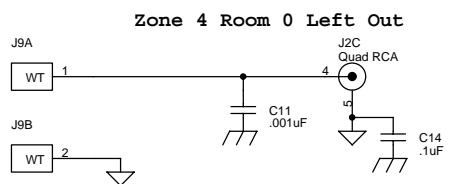
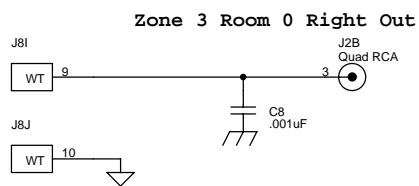
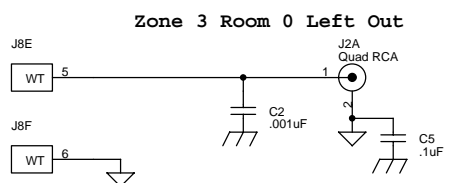
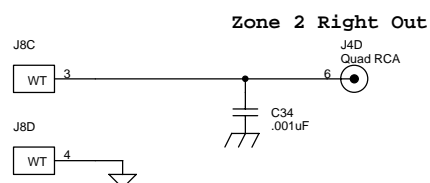
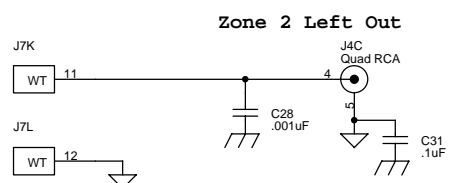
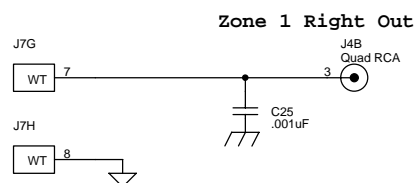
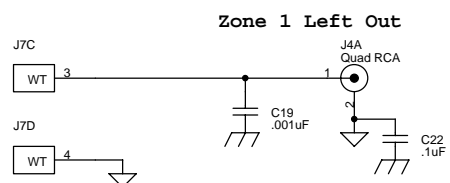
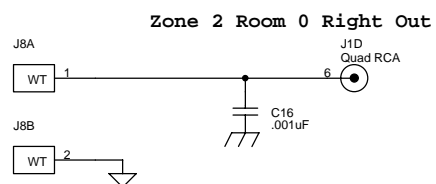
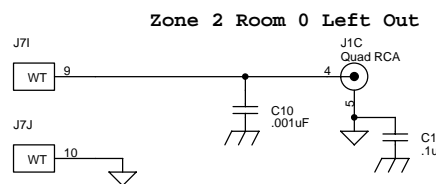
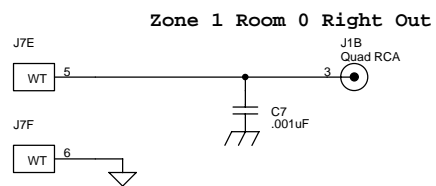
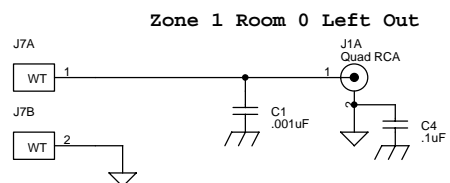

PX-700 IR OUTPUT BD

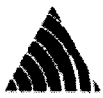

AUDIOACCESS *PX-700 Parts List*

803-00065-00, ASSEMBLY, PX700 IR OUTPUT BOARD

Item	Qty	Reference	PN	Description
40	1		403-00065-00	PCB, PX700 IR OUTPUT BOARD
150	36	R1,R2,R3,R4,R5,R6,R7,R8, R11,R12,R13,R14,R15,R16, R17,R18,R21,R22,R23,R24, R25,R26,R27,R28,R31,R32, R33,R34,R35,R36,R37,R38, R41,R42,R44	122-32100-00	RES, SMT, 1K, 5%, TF, 1/8W, 0805
210	1	U4	230-30138-00	DECODER, 3 TO 8, 74HC138, SOIC16N
200	1	U3	230-50004-00	INVERTER, NC7S04, SOT23-5
190	2	U1,U2	230-30002-00	NOR GATE, QUAD 2 IN, 74HC02, SOIC14N
180	1	R45	122-31100-00	RES, SMT, 100, 5%, TF, 1/8W, 0805
160	9	R9,R10,R19,R20,R29,R30, R39,R40,R46	122-34100-00	RES, SMT, 100K, 5%, TF, 1/8W, 0805
140	9	Q3,Q4,Q7,Q8,Q11,Q12,Q15 ,Q16,Q18	210-53904-00	TRANS, NPN, SMT, MMBT3904LT1, SOT23
130	9	Q1,Q2,Q5,Q6,Q9,Q10,Q13, Q14,Q17	211-53906-00	TRANS, NPN, SMT, MMBT3906LT1, SOT23
120	2	M1,M2	612-18190-00	BRACKET, PC MNT SCREW TERM, 8190 (NO SCRE
20	1		073-00065-00	PARTS PLACEMENT DIAGRAM, PX700 IR OUTPUT
170	2	R43,R47	122-33100-00	RES, SMT, 10K, 5%, TF, 1/8W, 0805
30	1		043-00065-00	ASSEMBLY DRAWING, PX700 IR OUTPUT BOARD
110	1	J11	320-55105-00	HEADER, 2X5, RA, SHROUDED
50	1		093-00065-00	FAB DRAWING, PX700 IR OUTPUT BOARD
60	9	C1,C2,C3,C4,C5,C6,C7,C8, C15	155-20147-00	CAP, SMT CER, 470pF, 50V, COG 5%, 0805
70	5	C9,C10,C11,C12,C16	155-21410-01	CAP, SMT CER, 0.1uF, 50V, X7R 10%, 0805
80	2	C14,C13	150-32310-00	CAP, SMT AL EL, 10uF, 25V, 20%
90	9	J1,J2,J3,J4,J5,J6,J7,J8,J9	321-20000-00	PHONE JACK, 3.5mm, MONO, SB
100	1	J10	320-52003-00	HEADER, 1X3



AUDIOACCESS *PX-700 Parts List*

803-00065-00, ASSEMBLY, PX700 IR OUTPUT BOARD

Item	Qty	Reference	PN	Description
10	1		053-00065-00	SCHEMATIC, PX700 IR OUTPUT BOARD

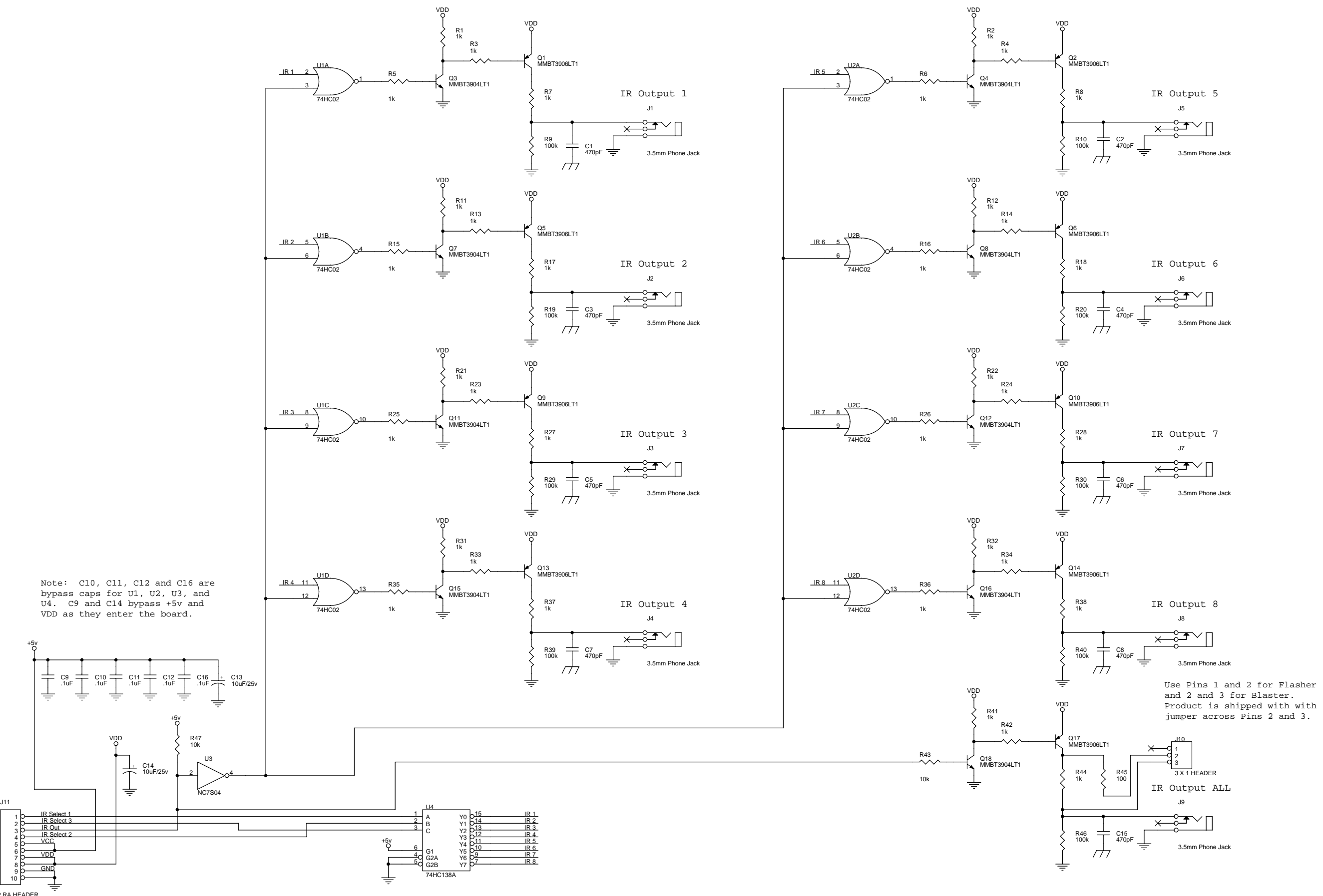

Note: C10, C11, C12 and C16 are bypass caps for U1, U2, U3, and U4. C9 and C14 bypass +5v and VDD as they enter the board.

Use Pins 1 and 2 for Flasher and 2 and 3 for Blaster. Product is shipped with with jumper across Pins 2 and 3.

PX-700 FRONT PANEL BD

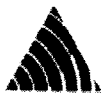

AUDIOACCESS **PX-700 Parts List**

806-00065-00, ASSEMBLY, PX700 FRONT PANEL BOARD

Item	qty	Reference	PN	Description
150	2	R11	122-31100-00	RES, SMT, 100, 5%, TF, 1/8W, 0805
140	1	J2	320-56105-00	HEADER, 1X5, RA, POL, SHROUDED, 2mm
130	1	J1	320-56110-00	HEADER, 1X10, RA, POL, SHROUDED, 2mm
120	1	D5	204-15570-00	LED, BI-COLOR, T1, 3.1mm, Y/G (570 nm) and R (630
160	3	R1,R2,R3,R5	122-32100-00	RES, SMT, 1K, 5%, TF, 1/8W, 0805
100	1	C6	155-21310-01	CAP, SMT CER, 0.01uF, 50V, X7R 10%, 0805
220	1	U1	272-13373-00	IR AMPLIFIER/DETECTOR, MC3373P
110	1	D4	209-00526-00	PHOTODIODE, IR, LTR526AB
170	3	R4,R12	122-33100-00	RES, SMT, 10K, 5%, TF, 1/8W, 0805
180	1	R7	122-33470-00	RES, SMT, 47K, 5%, TF, 1/8W, 0805
190	1	R8	122-30100-00	RES, SMT, 10, 5%, TF, 1/8W, 0805
90	3	C4,C9,C11	155-21410-01	CAP, SMT CER, 0.1uF, 50V, X7R 10%, 0805
210	1	S1	300-03200-00	SWITCH, PC, SPST MOM, E320E1-1, BLACK CAP
50	1		096-00065-00	FAB DRAWING, PX700 FRONT PANEL BOARD
230	1	U2	272-05380-00	IR RECEIVER, 38kHz, W/CLIP, TFMT 5380
240	2	U3,U4	230-50004-00	INVERTER, NC7S04, SOT23-5
250	1	D5	640-90350-00	SPACER, LED, TRILEAD, 0.350"
200	1	R10	122-31180-00	RES, SMT, 180, 5%, TF, 1/8W, 0805
60	1	C1	155-20210-00	CAP, SMT CER, 0.001uF, 50V, COG 5%, 0805
40	1		406-00065-00	PCB, PX700 FRONT PANEL BOARD
30	1		046-00065-00	ASSEMBLY DRAWING, PX700 FRONT PANEL BOAR
20	1		076-00065-00	PARTS PLACEMENT DIAGRAM, PX700 FRONT PAN
10	1		056-00065-00	SCHEMATIC, PX700 FRONT PANEL BOARD
70	1	C5,C2	150-42233-00	CAP, SMT AL EL , 3.3uF, 35V, 20%
80	4	C3,C7,C8,C10	150-22310-00	CAP, SMT AL EL, 10uF, 16V, 20%

TO CONTROLLER BOARD

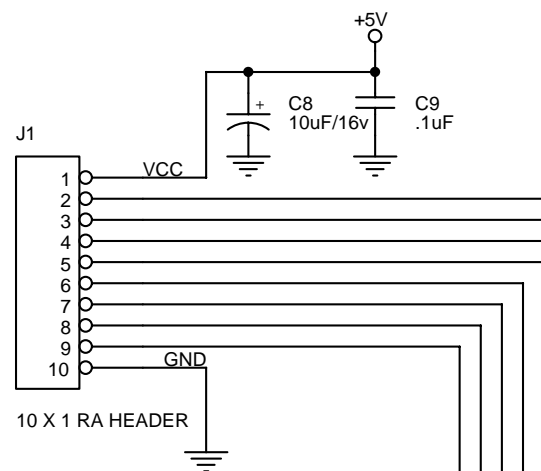

TO RS-232 BOARD

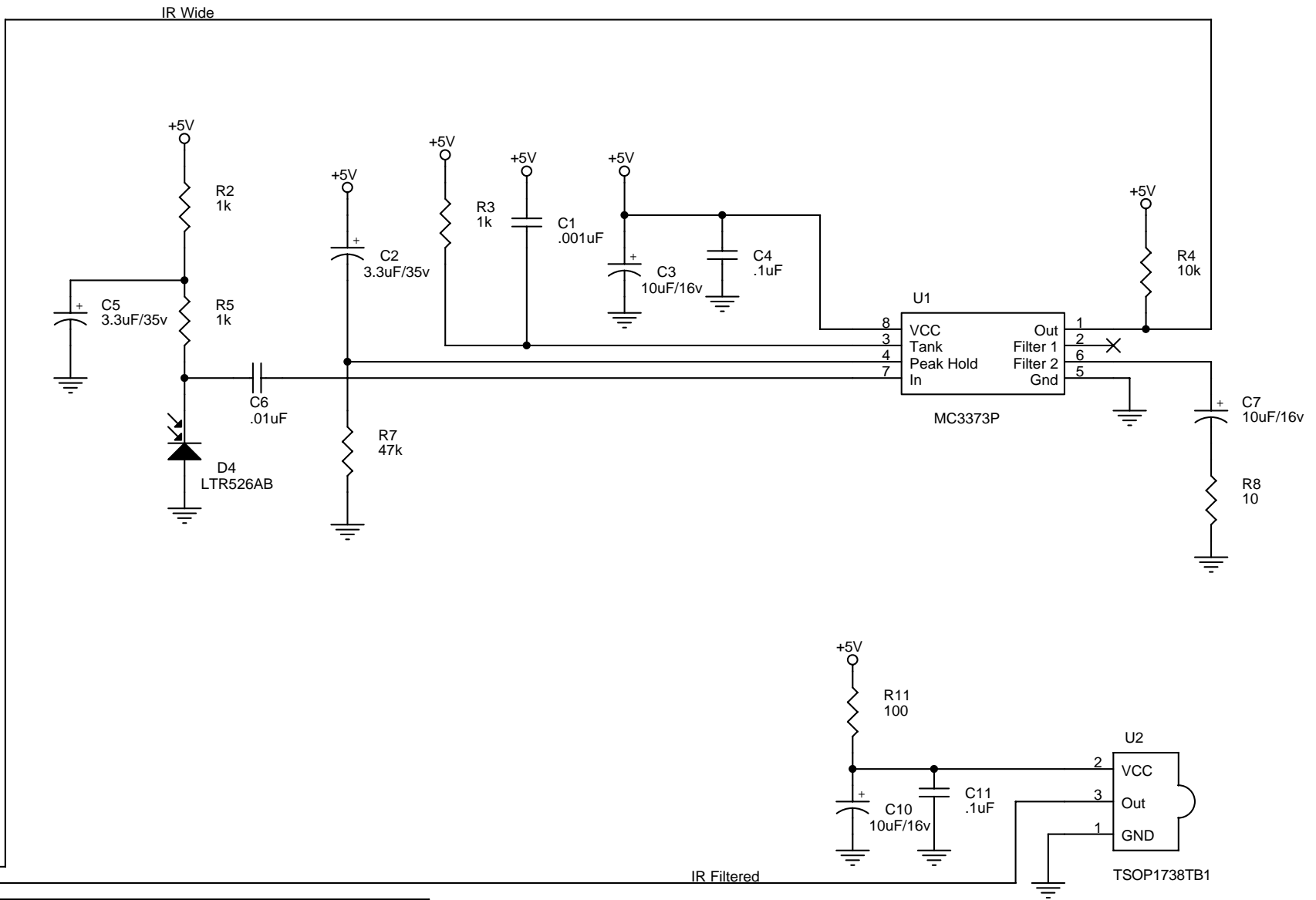
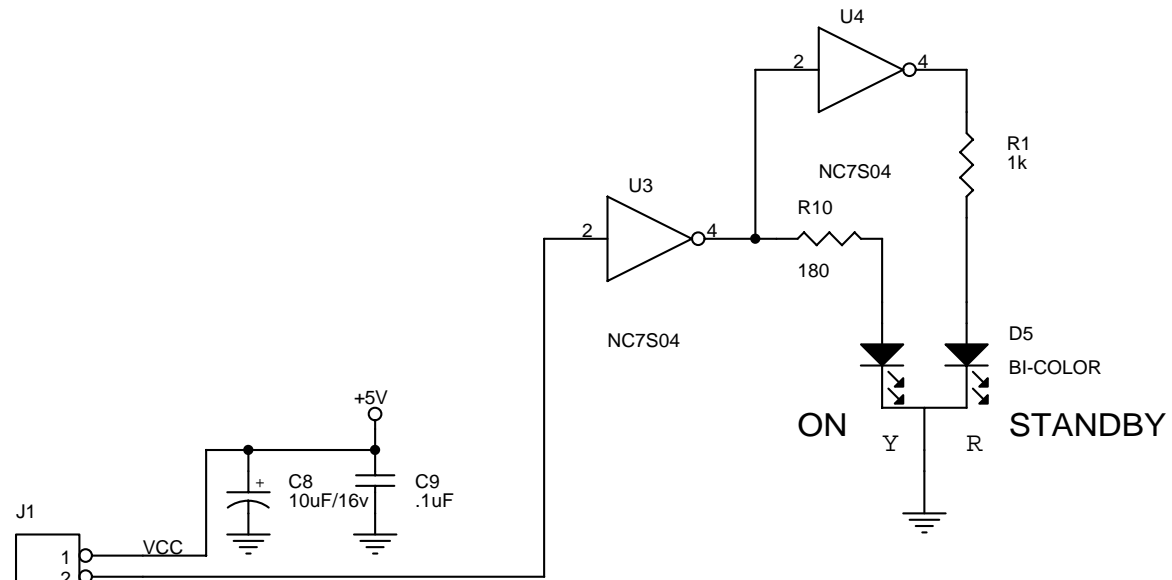
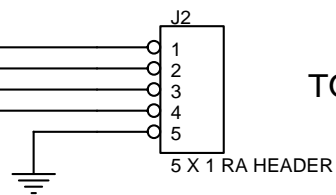

Title		
PX-700 FRONT PANEL BOARD		
Size	Document Number	Rev
B	056-00065	00
Date:	Friday, April 21, 2000	Sheet 1 of 1

PX-700 POWER INLET BD



80C-00065-00, ASSEMBLY, PX700 POWER INLET BOARD

Item	Qty	Reference	PN	Description
20	1		07C-00065-00	PARTS PLACEMENT DIAGRAM, PX700 POWER INLE
80	1	C1	143-68410-00	CAP, RAD PEF, 0.1uF, 250V, 20%, X RATED
70	3	J1,J2,J3	324-01021-00	CONN, QC PC MALE, 0.250"
60	1	J5	325-20580-00	CONN, AC, IEC320, PC MNT, FLANGED
50	1		09C-00065-00	FAB DRAWING, PX700 POWER INLET BOARD
30	1		04C-00065-00	ASSEMBLY DRAWING, PX700 POWER INLET BOAR
10	1		05C-00065-00	SCHEMATIC, PX700 POWER INLET BOARD
40	1		40C-00065-00	PCB, PX700 POWER INLET BOARD

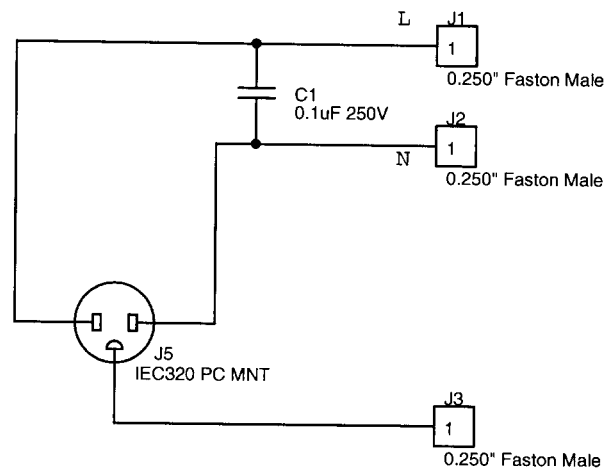

Title		
PX-700 Power Inlet Board		
Size	Document Number	Rev
A	05C-00065-00	00
Date:	Friday, April 21, 2000	Sheet 1 of 1

A

B

C

D

E

4

4

3

3

2

2

1

1

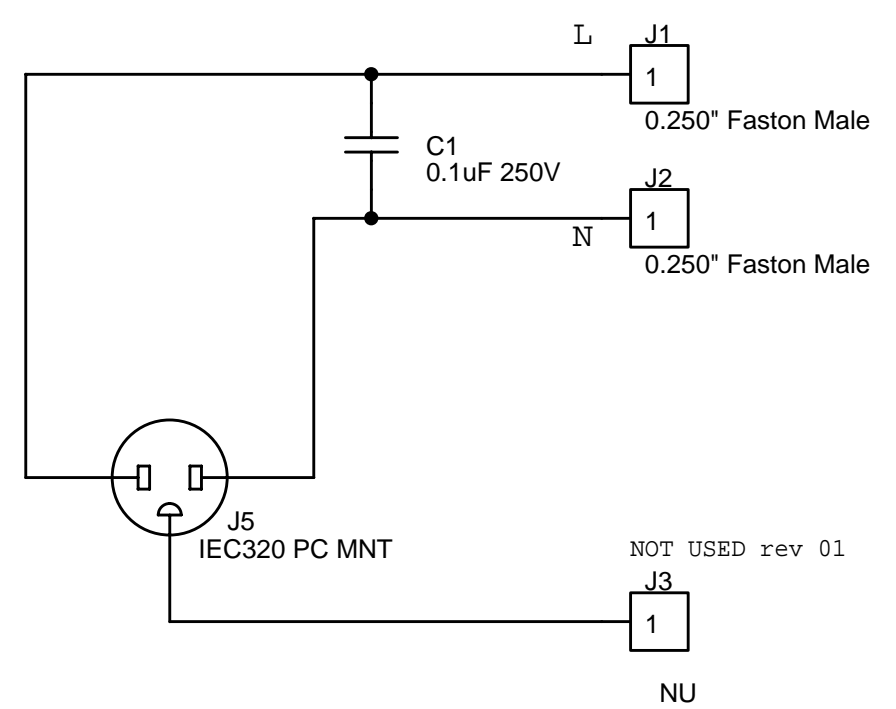

Title		
PX-700 Power Inlet Board		
Size	Document Number	Rev
A	05C-00065-00	01
Date:	Friday, September 20, 2002	Sheet 1 of 1

A

B

C

D

E

PX-700 Audio BD



AUDIOACCESS *PX-700 Parts List*

800-00065-01, ASSEMBLY, PX700 AUDIO BOARD

Item	qty	Reference	PN	Description
370	12	R91,R130,R168,R207,R245 ,R284,R322,R361,R399,R4 38,R476,R515	121-30681-00	RES, SMT, 681, 1%, TF, 1/8W, 0805
250	2	Q44,Q46	211-53906-00	TRANS, NPN, SMT, MMBT3906LT1, SOT23
260	2	Q45,Q47	210-53904-00	TRANS, NPN, SMT, MMBT3904LT1, SOT23
270	72	R1,R2,R3,R4,R9,R10,R11,R 12,R17,R18,R19,R20,R25,R 26,R27,R28,R33,R34,R35,R 36,R41,R42,R43,R44,R49,R 50,R51,R52,R57,R58,R59,R 60,R65,R67,R75,R76,R93,R 114,R115,R132,R152,R153, R170,R191,R192,R209,R22 9,R230,R247,R268,R269,R 286,R306,R307,R324,R345, R346,R363,R383,R3	122-31330-00	RES, SMT, 330, 5%, TF, 1/8W, 0805
280	17	R5,R6,R7,R8,R21,R22,R23, R24,R37,R38,R39,R40,R53, R54,R55,R56,R66	121-32200-00	RES, SMT, 20.0K, 1%, TF, 1/8W, 0805
290	43	R13,R14,R15,R16,R29,R30, R31,R32,R45,R46,R47,R48, R61,R62,R63,R64,R68,R82, R99,R119,R137,R159,R176 ,R196,R214,R236,R253,R2 73,R291,R313,R330,R350, R368,R390,R407,R427,R44 5,R467,R484,R504,R522,R 534,R538	122-32270-00	RES, SMT, 2.7K, 5%, TF, 1/8W, 0805
300	12	R70,R109,R147,R186,R224 ,R263,R301,R340,R378,R4 17,R455,R494	122-35100-00	RES, SMT, 1M, 5%, TF, 1/8W, 0805
310	142	R69,R72,R78,R80,R83,R87, R94,R100,R102,R104,R106 ,R108,R111,R117,R120,R1 22,R126,R133,R138,R140, R142,R144,R146,R149,R15 5,R157,R160,R164,R171,R 177,R179,R181,R183,R185, R188,R194,R197,R199,R20 3,R210,R215,R217,R219,R 221,R223,R226,R232,R234, R237,R241,R248,R254,R2	121-32100-00	RES, SMT, 10.0K, 1%, TF, 1/8W, 0805



AUDIOACCESS *PX-700 Parts List*

800-00065-01, ASSEMBLY, PX700 AUDIO BOARD

Item	qty	Reference	PN	Description
320	156	R71,R73,R74,R79,R86,R88, R90,R92,R95,R101,R103,R 105,R107,R110,R112,R113, R118,R125,R127,R128,R13 1,R135,R139,R141,R143,R 145,R148,R150,R151,R156, R163,R165,R167,R169,R17 2,R178,R180,R182,R184,R 187,R189,R190,R195,R202, R204,R205,R208,R211,R21 6,R218,R220,R222,R225	121-31200-00	RES, SMT, 2.00K, 1%, TF, 1/8W, 0805
330	12	R77,R116,R154,R193,R231 ,R270,R308,R347,R385,R4 24,R462,R501	122-34330-00	RES, SMT, 330K, 5%, TF, 1/8W, 0805
240	43	Q1,Q2,Q3,Q4,Q5,Q6,Q7,Q8 ,Q9,Q10,Q11,Q12,Q13,Q14, Q15,Q16,Q17,Q18,Q19,Q20 ,Q21,Q22,Q23,Q24,Q25,Q2 6,Q27,Q28,Q29,Q30,Q31,Q 32,Q33,Q34,Q35,Q36,Q37, Q38,Q39,Q40,Q41,Q42,Q43	210-53326-00	TRANS, NPN, SMT, MUTING, 2SC3326
350	12	R84,R123,R161,R200,R238 ,R277,R315,R354,R392,R4 31,R469,R508	121-33127-00	RES, SMT, 127K, 1%, TF, 1/8W, 0805
360	12	R85,R124,R162,R201,R239 ,R278,R316,R355,R393,R4 32,R470,R509	121-32147-00	RES, SMT, 14.7K, 1%, TF, 1/8W, 0805
390	12	R96,R134,R173,R212,R250 ,R289,R327,R366,R404,R4 43,R481,R520	122-33470-00	RES, SMT, 47K, 5%, TF, 1/8W, 0805
400	12	R97,R136,R174,R213,R251 ,R290,R328,R367,R405,R4 44,R482,R521	122-32330-00	RES, SMT, 3.3K, 5%, TF, 1/8W, 0805
410	6	R98,R175,R252,R329,R406 ,R483	122-30100-00	RES, SMT, 10, 5%, TF, 1/8W, 0805



AUDIOACCESS *PX-700 Parts List*

800-00065-01, ASSEMBLY, PX700 AUDIO BOARD

Item	Qty	Reference	PN	Description
420	42	U1,U2,U3,U4,U5,U6,U7,U8, U9,U10,U11,U12,U13,U14, U15,U16,U17,U18,U22,U23, U25,U27,U31,U33,U35,U36, U40,U42,U44,U45,U49,U51, U53,U54,U58,U60,U62,U63, U67,U69,U71,U72	221-30072-00	OPAMP, DUAL LN JFET, TL072, SMT
430	12	U19,U20,U28,U29,U37,U38, U46,U47,U55,U56,U64,U65	232-34051-00	ANALG SWTCH, SINGLE, 8 TO 1, CD4051B, SMT
440	6	U21,U30,U39,U48,U57,U66	232-34052-00	ANALG SWTCH, DUAL, 4 TO 1, CD4052B, SMT
450	6	U24,U32,U41,U50,U59,U68	224-33310-00	VOLUME CONTROL, STEREO, DIGITAL, CS3310, SM
460	6	U26,U34,U43,U52,U61,U70	224-09184-00	TONE CONTROL, DIGITAL CONTROL, TC9184P
470	6	U73,U74,U75,U76,U77,U78	230-30574-00	D FLIP FLOP, OCT 3STATE, 74HC574, SMT
340	12	R81,R121,R158,R198,R235 ,R275,R312,R352,R389,R4 29,R466,R506	121-31150-00	RES, SMT, 1.50K, 1%, TF, 1/8W, 0805
70	53	C5,C6,C7,C8,C9,C10,C11,C 12,C21,C22,C23,C24,C33,C 34,C35,C36,C37,C38,C39,C 40,C45,C46,C47,C48,C53,C 54,C55,C56,C57,C58,C59,C 60,C69,C70,C71,C72,C81,C 82,C83,C84,C85,C86,C87,C 88,C93,C94,C95,C96,C98,C 99,C102,C399,C403	155-20210-00	CAP, SMT CER, 0.001uF, 50V, COG 5%, 0805
380	14	R89,R129,R166,R206,R243 ,R283,R320,R360,R397,R4 37,R474,R514,R542,R546	122-34100-00	RES, SMT, 100K, 5%, TF, 1/8W, 0805
230	2	M1,M2	612-18190-00	BRACKET, PC MNT SCREW TERM, 8190 (NO SCRE
10	1		050-00065-01	SCHEMATIC, PX700 AUDIO BOARD
20	1		070-00065-00	PARTS PLACEMENT DIAGRAM, PX700 AUDIO BOAR
30	1		040-00065-00	ASSEMBLY DRAWING, PX700 AUDIO BOARD
40	1		400-00065-00	PCB, PX700 AUDIO BOARD

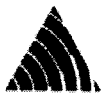

AUDIOACCESS **PX-700 Parts List**

800-00065-01, ASSEMBLY, PX700 AUDIO BOARD

Item	Qty	Reference	PN	Description
60	180	C1,C2,C3,C4,C13,C14,C15, C16,C17,C18,C19,C20,C25, C26,C27,C28,C29,C30,C31, C32,C41,C42,C43,C44,C49, C50,C51,C52,C61,C62,C63, C64,C65,C66,C67,C68,C73, C74,C75,C76,C77,C78,C79, C80,C89,C90,C91,C92,C97, C100,C101,C106,C107,C10 9,C110,C114,C115,C117,C 120,C122,C124,C12	155-21410-01	CAP, SMT CER, 0.1uF, 50V, X7R 10%, 0805
80	24	C105,C121,C135,C147,C15 4,C170,C184,C196,C203,C 219,C233,C245,C252,C268, C282,C294,C301,C317,C33 1,C343,C350,C366,C380,C 392	155-20110-00	CAP, SMT CER, 100pF, 50V, COG 5%, 0805
90	12	C104,C134,C153,C183,C20 2,C232,C251,C281,C300,C 330,C349,C379	155-20022-00	CAP, SMT CER, 22pF, 50V, COG 5%, 0805
100	14	C103,C133,C152,C182,C20 1,C231,C250,C280,C299,C 329,C348,C378,C397,C402	155-20047-00	CAP, SMT CER, 47pF, 50V, COG 5%, 0805
110	48	C108,C138,C157,C187,C20 6,C236,C255,C285,C304,C 334,C353,C383,C415,C416, C417,C418,C419,C420,C42 1,C422,C423,C424,C425,C 426,C427,C428,C429,C430, C431,C432,C433,C434,C43 5,C436,C437,C438,C439,C 440,C441,C442,C443,C444, C445,C446,C447,C448,C44 9,C450	143-23410-00	CAP, RAD PEF, 0.1uF, 63V, 5%, BOX
200	4	J10,J11,J12,J13	320-00512-00	CONN, WIRE TRAP, 2mm ST, 12 COND
220	1	J15	320-52208-00	HEADER, 1X8, ST, POL, LOCKRAMP
50	1		090-00065-00	FAB DRAWING, PX700 AUDIO BOARD
210	1	J14	320-55010-00	HEADER, 2X10, SHROUDED
190	9	J1,J2,J3,J4,J5,J6,J7,J8,J9	321-02001-00	RCA JACK, 14mm QUAD, R/W
180	2	D2,D1	201-54148-00	DIODE, SWITCHING, SMT, MMBD4148



AUDIOACCESS *PX-700 Parts List*

800-00065-01, ASSEMBLY, PX700 AUDIO BOARD

Item	Qty	Reference	PN	Description
170	12	C128,C151,C177,C200,C226,C249,C275,C298,C324,C347,C373,C396	143-33318-00	CAP, RAD PEF, 0.018uF, 100V, 5%, BOX
160	12	C123,C148,C172,C197,C221,C246,C270,C295,C319,C344,C368,C393	143-33368-00	CAP, RAD PEF, 0.068uF, 100V, 5%, BOX
150	12	C119,C146,C168,C195,C217,C244,C266,C293,C315,C342,C364,C391	143-33315-00	CAP, RAD PEF, 0.015uF, 100V, 5%, BOX
140	12	C116,C143,C165,C192,C214,C241,C263,C290,C312,C339,C361,C388	143-33239-00	CAP, RAD PEF, 0.0039uF, 100V, 5%, BOX
130	36	C112,C113,C118,C140,C141,C144,C161,C162,C167,C189,C190,C193,C210,C211,C216,C238,C239,C242,C259,C260,C265,C287,C288,C291,C308,C309,C314,C336,C337,C340,C357,C358,C363,C385,C386,C389	140-32347-00	CAP, RAD AL EL, 47uF, 25V, 20%
120	30	C111,C125,C126,C129,C139,C160,C174,C175,C178,C188,C209,C223,C224,C227,C237,C258,C272,C273,C276,C286,C307,C321,C322,C325,C335,C356,C370,C371,C374,C384	140-42310-00	CAP, RAD AL EL, 10uF, 35V, 20%

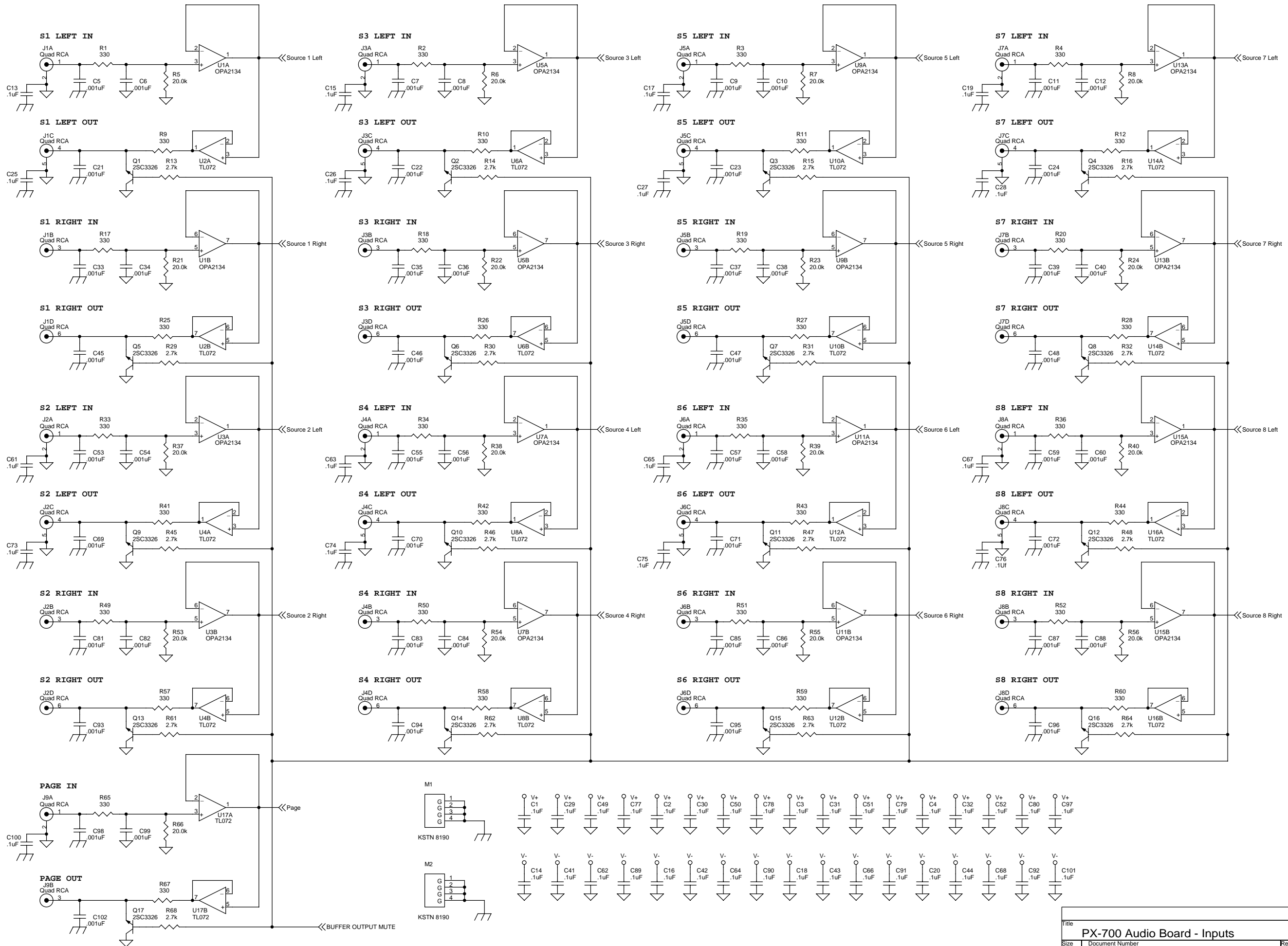

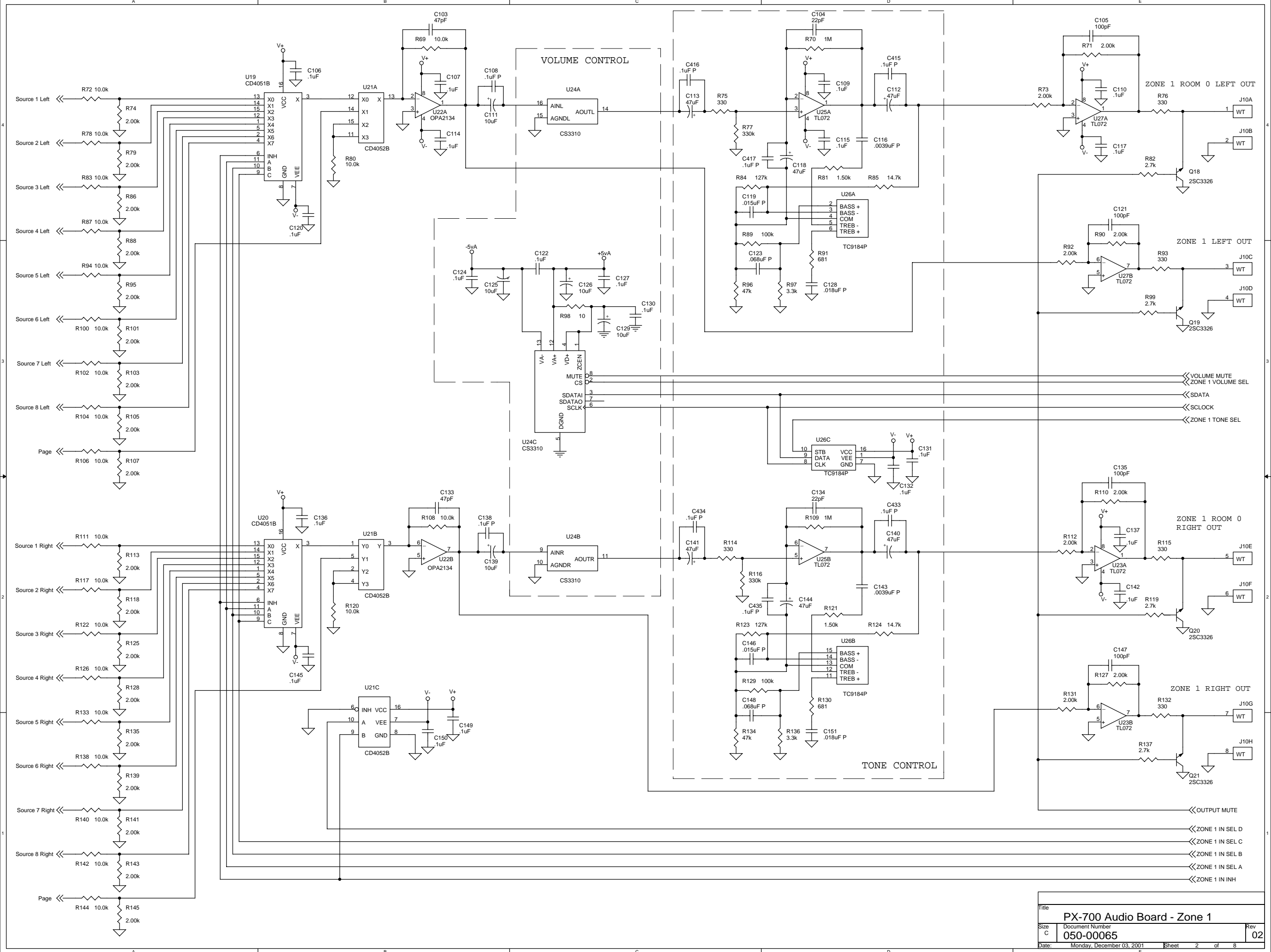

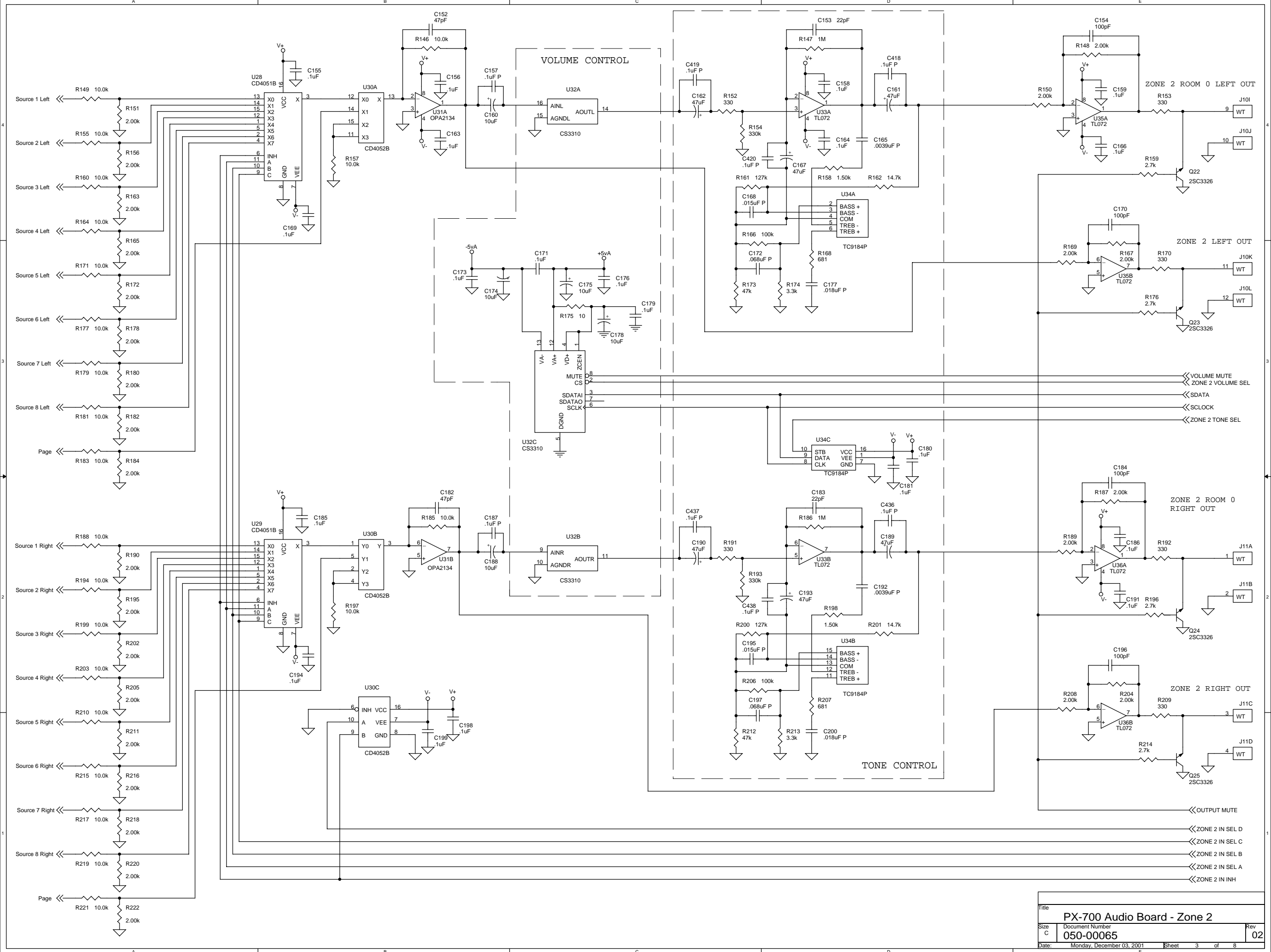

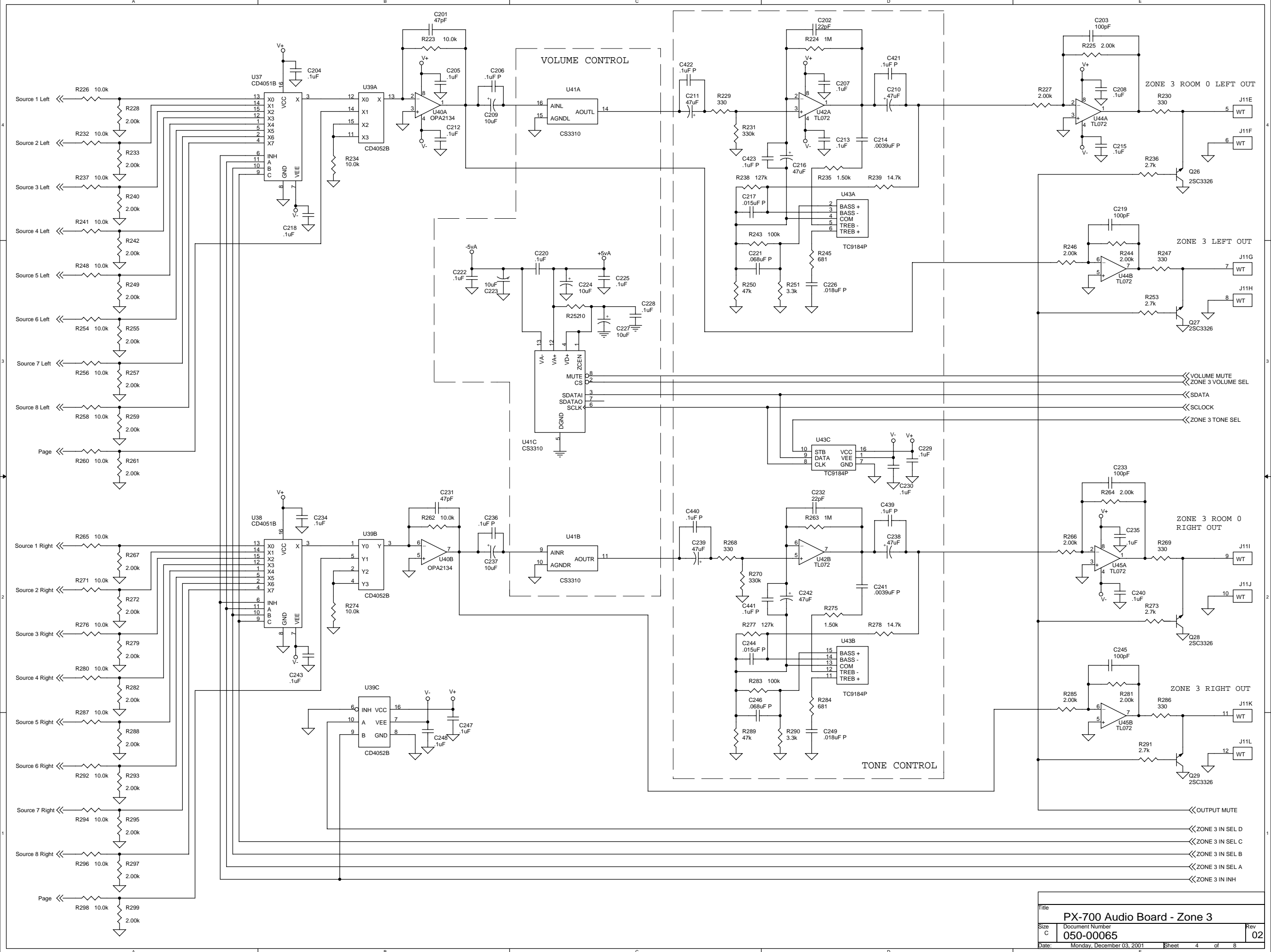

Title			PX-700 Audio Board - Zone 3		
Size	Document Number		Rev		
C	050-00065				02
Date:	Monday, December 03, 2001	Sheet	4	of	8

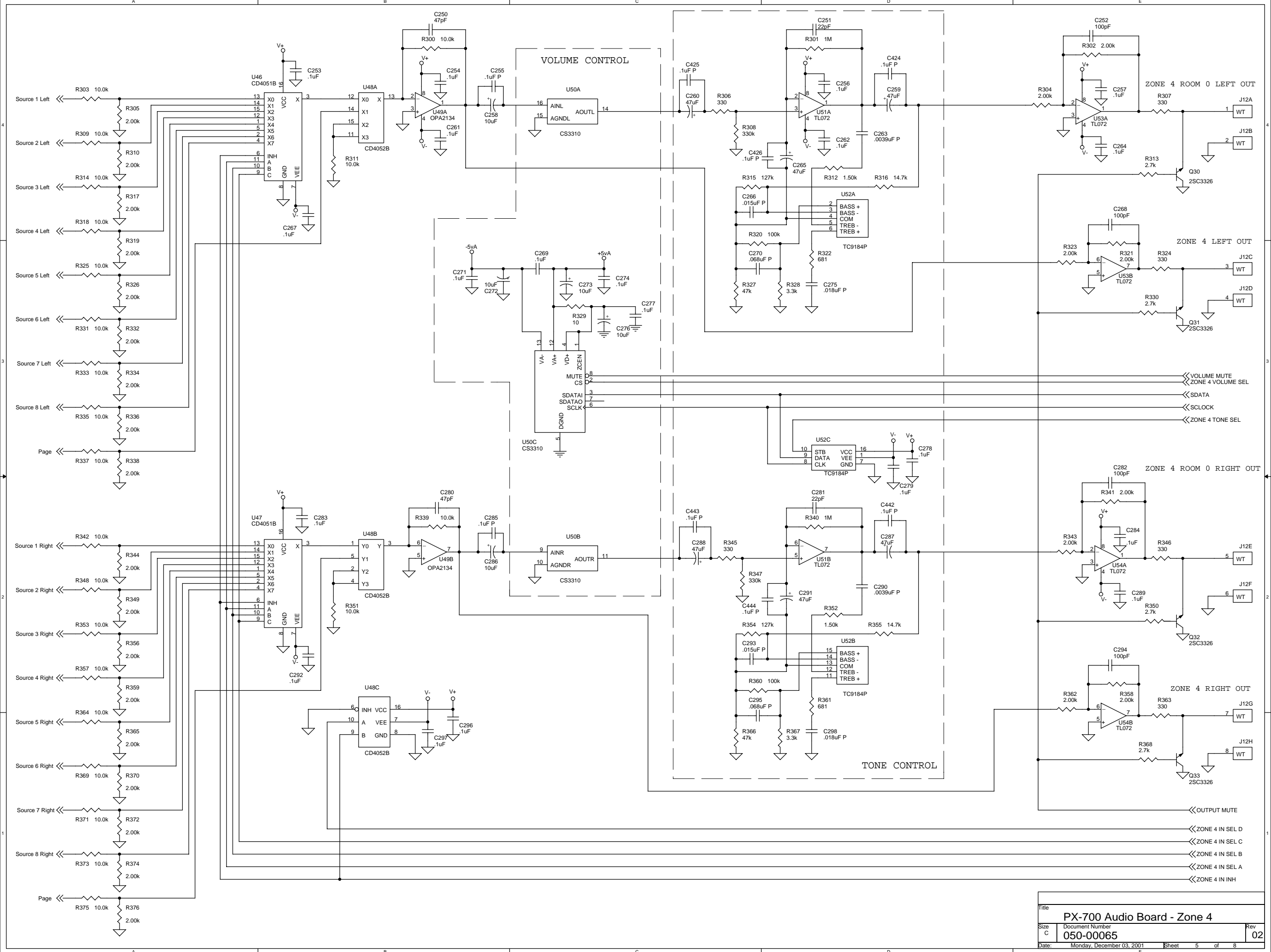

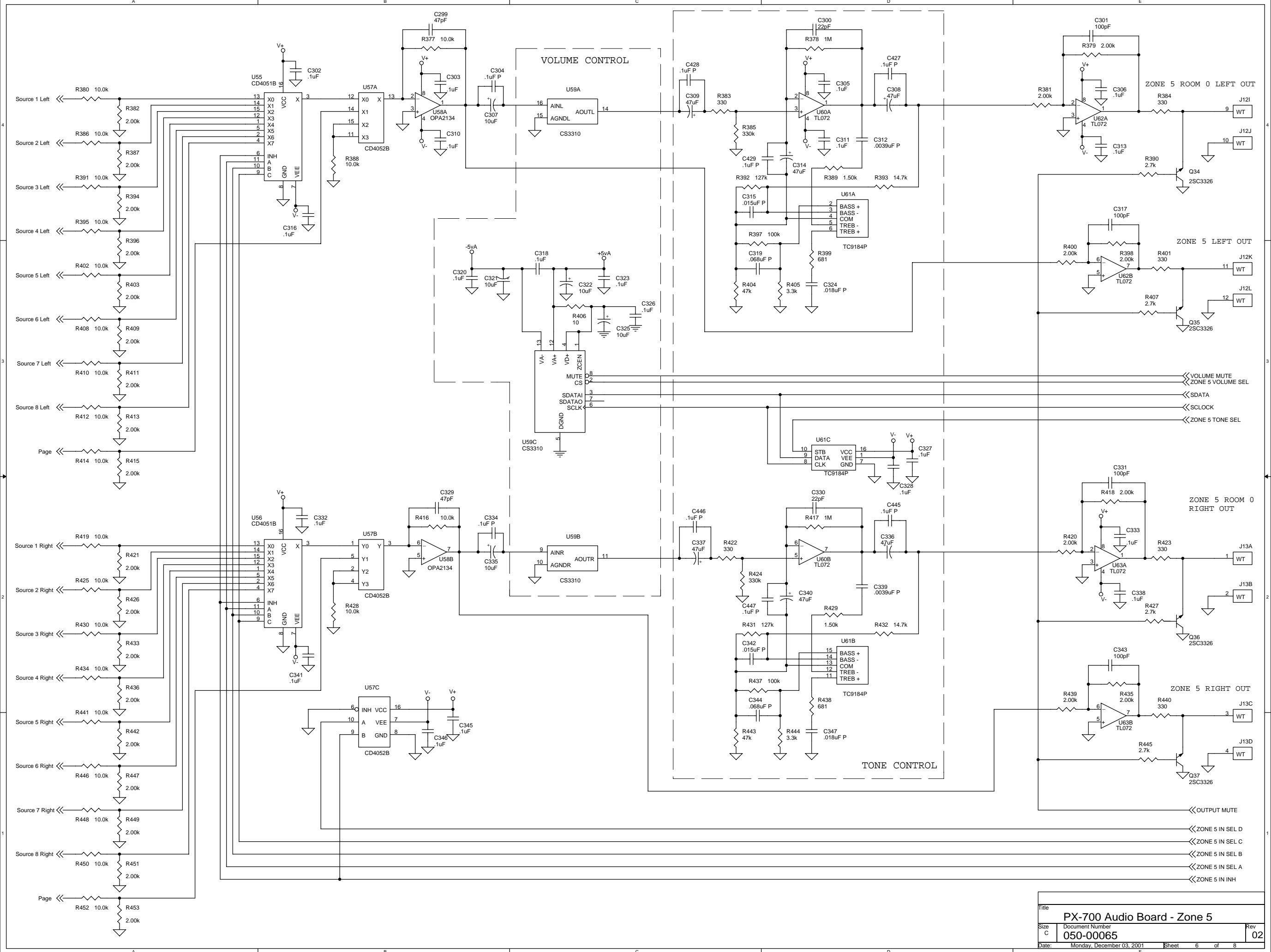

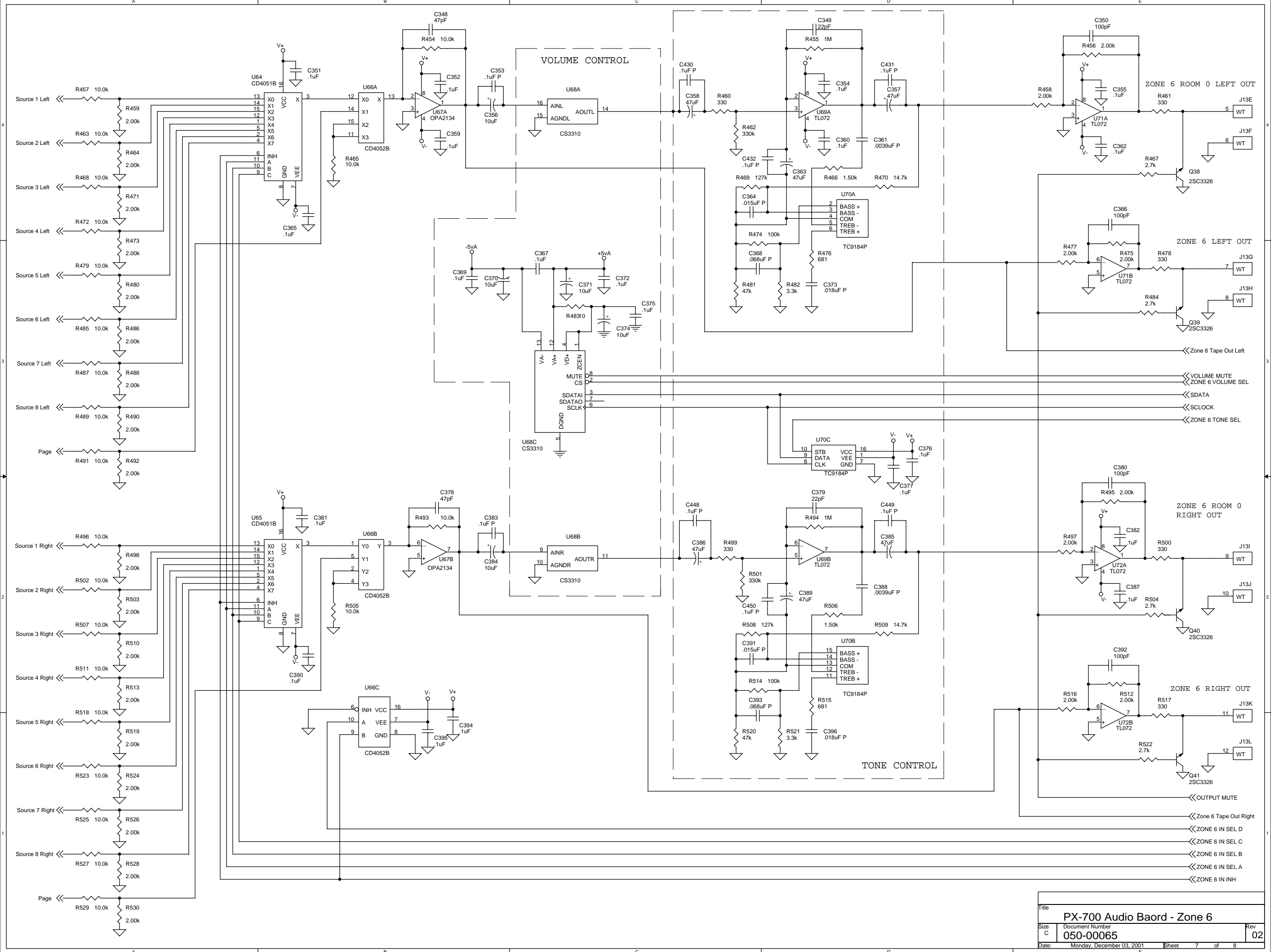

Title			PX-700 Audio Board - Zone 6		
Size	Document Number	Rev			
C	050-00065	02			
Date:	Monday, December 03, 2001	Sheet	7	of	8

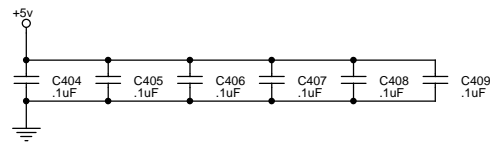
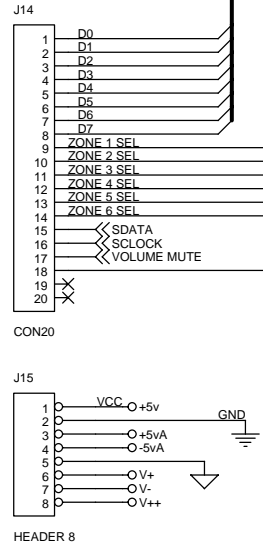
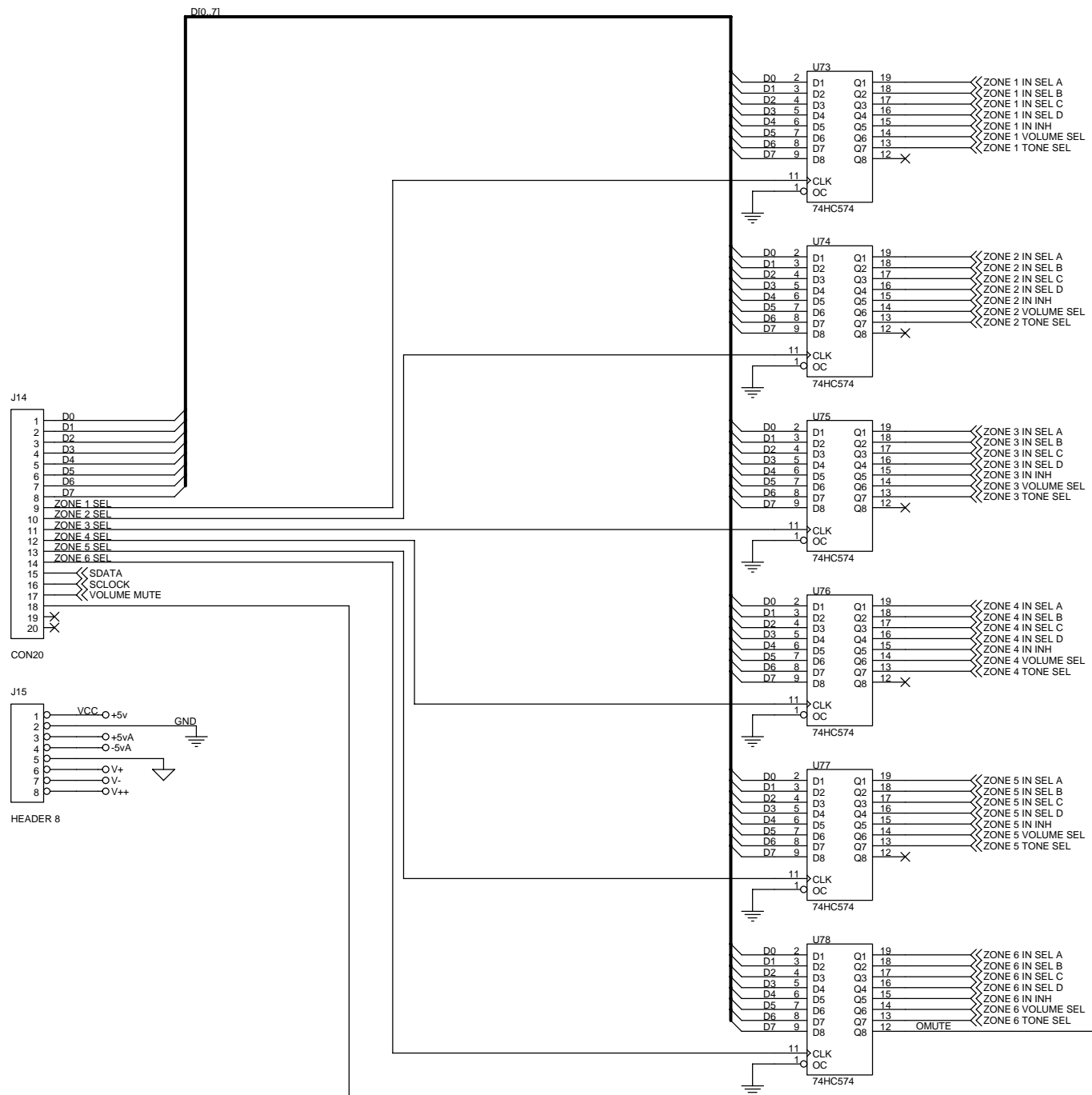

POWER ON/OFF MUTE

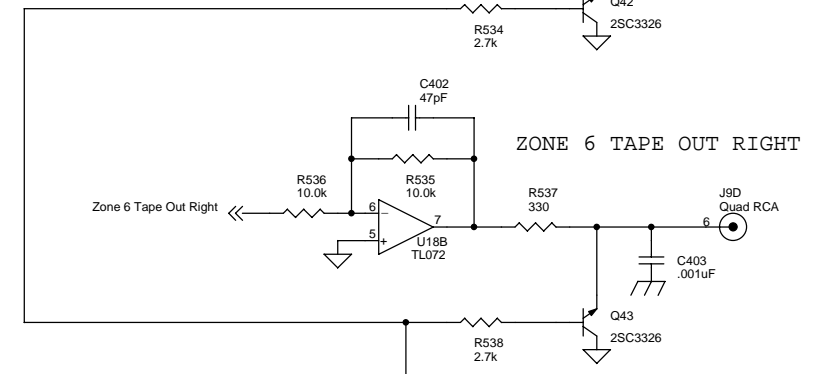
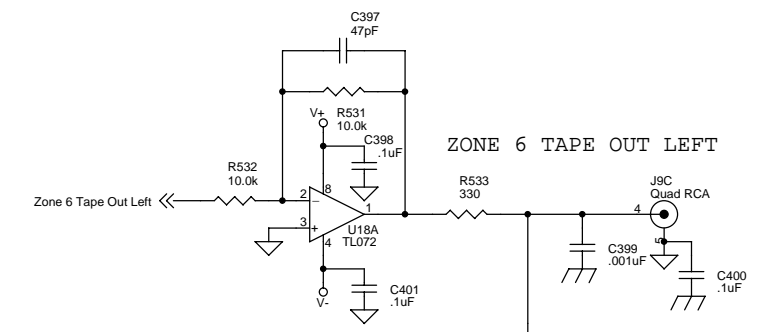
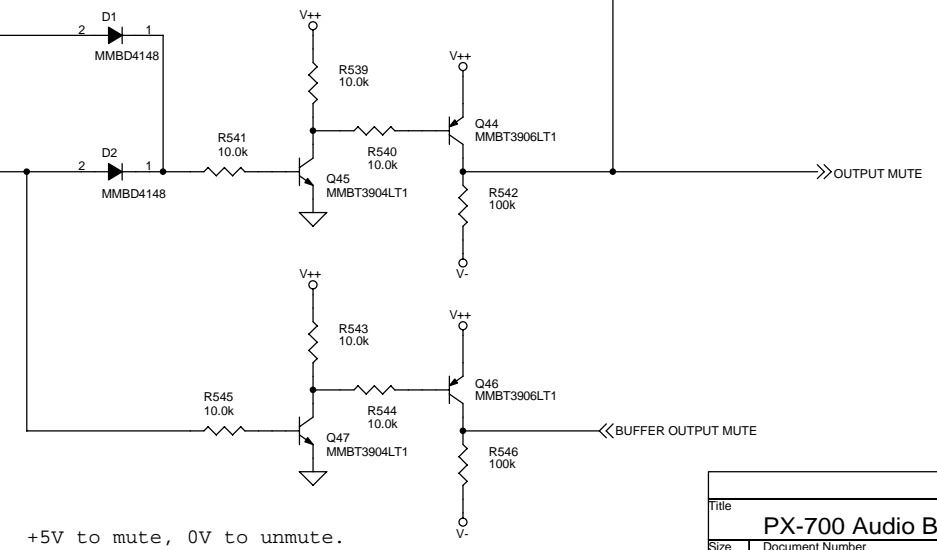

PX-700 120V Main Parts List		PX-700 120V				
Qty	Reference Designator	Part Number	Description	Vendor	Order Number	Madrigal PN
1		809-00066-00	FINISHED GOOD, PX-700, 120V	MADRIGAL		
1		010-00066-06	BOM, PX-700, 120V			ECN2760
1		800-3160-000-00	SHIPPING BOX, KRAFT			
1		805-3000-007	SHIPPING FOAM SET, PX-600/PX-612			
1		801-3350-000	SHIPPING BAG 9/12/MIL CLEAR POLY	NORTHEAST POLY	#480	ECN2823
1		801-3150-000	SHIPPING BAG, ANTI-STATIC			
1		688-2500-000	POWER CORD, 8 FT. IEC, USA	PACIFIC ELECTRICORD	C-3120-008-BL	
1		508-00000-00	SAFETY WARNING SHEET, AUDIOACCESS			
1		800-4000-000-A	AUDIOACCESS WARRANTY CARD			
1		826-0603-002-A	AUDIOACCESS WARRANTY SHEET			
1		808-00066-00	FINAL ASSEMBLY, PX-700, 120V	MADRIGAL		
1		048-00066-02	ASSEMBLY DRAWING, FINAL ASSEMBLY, PX-700 US			
6"		735-3500-100	TAPE, VINYL FOAM, ADHESIVE, 1/16 X 1/2"	3M	#4726	
1		474-00065-00	CHASSIS GROUND LABEL			
1		924-00065-00	ARTWORK, CHASSIS GND LABEL			
1		470-00066-01	LABEL, SAFETY/FCC WARNINGS			
1		922-00066-00	ARTWORK, SAFETY/FCC LABEL			
1		410-00066-01	CHASSIS, PX-700, US			ECN2764
1		921-00066-01	ARTWORK, REAR PANEL, PX-700, 120V			ECN2764
1		411-00065-00	TOP COVER, PX-700			
4		720-2500-010	FOOT, SNAP IN, GOLD			
1		80E-00066-00	ASSEMBLY, ACCESSORY OUTLET, 120V	MADRIGAL		
1		690-3000-001	CONN. AC FEMALE RECEPTACLE	POWER DYNAMICS	PD-15-1	
1		453-00065-00	WIRE ASS'Y, 9.00", BLACK, 18AWG, 0.250" FF/ST			
1		454-00065-00	WIRE ASS'Y, 9.00", WHITE, 18AWG, 0.250" FF/ST			
1		370-00065-02	POWER TRANSFORMER, PX-700, 115/230V, 50/60 HZ	POWERTRONIX	AA-96638-C	ECN2742
1		451-00065-01	WIRE ASS'Y, 13.50", BLACK, 18AWG, 0.250" FF X 2			
1		452-00065-01	WIRE ASS'Y, 7.00", BLACK, 18AWG, 0.250" FF X 2			
1		455-00065-00	WIRE ASS'Y, 8.00", WHITE, 18AWG, 0.250" FF X 2			
1		458-00065-01	WIRE ASS'Y, 4.50", GRN/YEL, 18AWG, 0.250" FF/RT			
1		459-00065-00	WIRE ASS'Y, 1.00", 4 COND			
1		45A-00065-00	WIRE ASS'Y, 1.50", 8 COND			
1		461-00065-01	RIBBON ASS'Y, 2.75", 10 COND			
1		462-00065-01	RIBBON ASS'Y, 1.75", 14 COND			
1		463-00065-00	RIBBON ASS'Y, 1.00", 20 COND			
1	Transformer	600-40011-00	SCREW, MCH PH PN ZNC, 8-32X1.375"	ANY VENDOR		420805
1	Transformer	610-40200-00	NUT, 8-32, ZINC, NYLOCK	ANY VENDOR		420606
1	Ground	600-20004-00	SCREW, MCH PH PN ZNC, 6-32X0.500"	ANY VENDOR		420006
1	Ground	420094	WASHER, #6 ZNC INTRNL TOOTH STAR	ANY VENDOR		734-3500-006
4	Ground, Power Inlet	610-20100-00	NUT, 6-32, KEP	ANY VENDOR		420842, 736-2117-001
15	Chassis	603-20102-00	SCREW, ST PH PN BLK, 6-32X0.250"	ANY VENDOR		730-2321-101
20	Board Mounting	600-23002-00	SCREW, MCH PH PN ZNC SEMS, 6-32X0.250"	ANY VENDOR		4200942
2	Power Inlet	600-20103-00	SCREW, MCH PH PN BLK, 6-32X0.375"	ANY VENDOR		420004, 730-2321-001
15		602-10103-00	SCREW, SM PH PN BLK, #4X0.375"	ANY VENDOR		730-2320-000
2	RS-232 Connector	605-12202-00	SCREW, JACK, 3/16 HEX YEL CHROMATE, 4-40X0.250"	RAF	4750-2 (NO HARDWARE)	
6		735-4500-000	CABLE TIE, 4"	ANY VENDOR		
1	Controller Board Fuseholder	380-00160-00	FUSE, 5X20MM, SLOW BLOW, UL/CSA, 250V, 1.6A	BUSSMANN	GMD 1.6A	
1	Power Supply Board, F1	380-00050-00	FUSE, 5X20MM, SLOW BLOW, UL/CSA, 250V, 500MA	BUSSMANN	GMD 500mA	
1	Power Supply Board, F2	380-00250-00	FUSE, 5X20MM, SLOW BLOW, UL/CSA, 250V, 2.5A	BUSSMANN	GMD 2.5A	350207
1	Inside chassis new power supply	473-00066-00	LABEL, FUSE WARNING, 120V	APEX		
1		923-00066-00	ARTWORK, FUSE WARNING LABEL, 120V			
1		262-01212-00	EPROM, 64KX8, 120nS, 27C512-12	AMD	AM27C512-120DC	
1	IR Board J10 Pins 1 and 2	320-59902-00	SHUNT JUMPER, 1X2			330228, 667-2236-000
1	Keypad Connector	323-05004-00	CONN, TERM BLK, PLG, RA, 4 PIN	WEILAND	25.320.3453.1	667-1000-006
1		800-00065-02	ASSEMBLY, PX700 AUDIO BOARD	CARLTON		
1		801-00065-00	ASSEMBLY, PX700 AUDIO OUTPUT BOARD	CARLTON		
1		802-00065-00	ASSEMBLY, PX700 CONTROLLER BOARD	CARLTON		
1		803-00065-00	ASSEMBLY, PX700 IR OUTPUT BOARD	CARLTON		
1		804-00065-00	ASSEMBLY, PX700 TRIGGER OUTPUT BOARD	CARLTON		
1		805-00066-00	ASSEMBLY, PX700 POWER SUPPLY BOARD, 120V	CARLTON		

1		80C-00065-01	ASSEMBLY, PX700 POWER INLET BOARD	CARLTON	
1		80D-00065-00	ASSEMBLY, PX700 FRONT PANEL PX-700 120V	MADRIGAL	ECN2760
1		430-00065-00	PLSTC PX700 SWITCH CAP		ECN2760
1		412-00065-00	Z BRACKET, PX-700		
1		420-00065-00J	FRONT PANEL, PX-700		
1		920-00065-P1	ARTWORK, FRONT PANEL, PX-700		
1		780-0600-050	END CAP, RIGHT, TAC 90MM		
1		780-0600-051	END CAP, LEFT, TAC 90MM		
1		780-0600-002	BEZEL LIGHT PIPE, TAC		
1		780-0600-100	WINDOW, IR		
1		440-00065-01	ADHESIVE, DIE CUT, PX-700 FRONT PANEL		
4		600-13002-00	SCREW, MCH PH PN SEMS ZNC, 4-40X0.250"	ANY VENDOR	
6		603-20102-00	SCREW, ST PH PN BLK, 6-32X0.250"	ANY VENDOR	730-2321-101
1		45B-00065-01	WIRE ASSY, 14.00", 5 COND		
1		450-00065-01	WIRE ASSY, 13.00", 10 COND		
1		806-00065-00	ASSEMBLY, PX700 FRONT PANEL BOARD	CARLTON	ECN2749
1		80A-00065-00	ASSEMBLY, PX700 RS232 INPUT BOARD	CARLTON	
1		80B-00065-01	ASSEMBLY, PX700 POWER SWITCH BOARD	CARLTON	
800-00065-00 REV 02, ASSEMBLY, PX700 AUDIO BOARD					
Qty	Reference Designator	Part Number	Description	Vendor	Order Number
1		050-00065-02	SCHEMATIC, PX700 AUDIO BOARD		
1		070-00065-00	PARTS PLACEMENT DIAGRAM, PX700 AUDIO BOARD		
1		040-00065-00	ASSEMBLY DRAWING, PX700 AUDIO BOARD		
1		400-00065-00	PCB, PX700 AUDIO BOARD		
1		090-00065-00	FAB DRAWING, PX700 AUDIO BOARD		
180	C1,C2,C3,C4,C13,C14,C15,C16,C17,C18,C19,C20,C25,C26,C27,C28,C29,C30,C31,C32,C41,C42,C43,C44,C49,C50,C51,C52,C61,C62,C63,C64,C65,C66,C67,C68,C73,C74,C75,C76,C77,C78,C79,C80,C89,C90,C91,C92,C97,C100,C101,C106,C107,C109,C110,C114,C115,C117,C120,C122,C124,C127,C130,C131,C132,C136,C137,C142,C145,C149,C150,C155,C156,C158,C159,C163,C164,C166,C169,C171,C173,C176,C179,C180,C181,C185,C186,C191,C194,C198,C199,C204,C205,C207,C208,C212,C213,C215,C218,C220,C222,C225,C228,C229,C230,C234,C235,C240,C243,C247,C248,C253,C254,C256,C257,C261,C262,C264,C267,C269,C271,C274,C277,C278,C279,C283,C284,C289,C292,C296,C297,C302,C303,C305,C306,C310,C311,C313,C316,C318,C320,C323,C326,C327,C328,C332,C333,C338,C341,C345,C346,C351,C352,C354,C355,C359,C360,C362,C365,C367,C369,C372,C375,C376,C377,C381,C382,C387,C390,C394,C395,C398,C400,C401,C404,C405,C406,C407,C408,C409	155-21410-01	CAP, SMT CER, 0.1uF, 50V, X7R 10%, 0805	PACCOM	MT104K050X7R0805
53	C5,C6,C7,C8,C9,C10,C11,C12,C21,C22,C23,C24,C33,C34,C35,C36,C37,C38,C39,C40,C45,C46,C47,C48,C53,C54,C55,C56,C57,C58,C59,C60,C69,C70,C71,C72,C81,C82,C83,C84,C85,C86,C87,C88,C93,C94,C95,C96,C98,C99,C102,C399,C403	155-20210-00	CAP, SMT CER, 0.001uF, 50V, COG 5%, 0805	PACCOM	MT102J050COG0805

24	C105,C121,C135,C147,C154,C170,C184,C196,C203,C219,C233,C245,C252,C268,C282,C294,C301,C317,C331,C343,C350,C366,C380,C392	155-20110-00	CAP, SMT CER, 100pF, 50V, COG 5%, 0805 PX-700 120V	PACCOM	MT101J050COG0805
12	C104,C134,C153,C183,C202,C232,C251,C281,C300,C330,C349,C379	155-20022-00	CAP, SMT CER, 22pF, 50V, COG 5%, 0805	PACCOM	MT220J050COG0805
14	C103,C133,C152,C182,C201,C231,C250,C280,C299,C329,C348,C378,C397,C402	155-20047-00	CAP, SMT CER, 47pF, 50V, COG 5%, 0805	PACCOM	MT470J050COG0805
48	C108,C138,C157,C187,C206,C236,C255,C285,C304,C334,C353,C383,C415,C416,C417,C418,C419,C420,C421,C422,C423,C424,C425,C426,C427,C428,C429,C430,C431,C432,C433,C434,C435,C436,C437,C438,C439,C440,C441,C442,C443,C444,C445,C446,C447,C448,C449,C450	143-23410-00	CAP, RAD PEF, 0.1uF, 63V, 5%, BOX	PACCOM	68104J063B5S5
30	C111,C125,C126,C129,C139,C160,C174,C175,C178,C188,C209,C223,C224,C227,C237,C258,C272,C273,C276,C286,C307,C321,C322,C325,C335,C356,C370,C371,C374,C384	140-42310-00	CAP, RAD AL EL, 10uF, 35V, 20%	PACCOM	EVR106M035V5X11A2.5
36	C112,C113,C118,C140,C141,C144,C161,C162,C167,C189,C190,C193,C210,C211,C216,C238,C239,C242,C259,C260,C265,C287,C288,C291,C308,C309,C314,C336,C337,C340,C357,C358,C363,C385,C386,C389	140-32347-00	CAP, RAD AL EL, 47uF, 25V, 20%	PACCOM	EVR47M25AA7
12	C116,C143,C165,C192,C214,C241,C263,C290,C312,C339,C361,C388	143-33239-00	CAP, RAD PEF, 0.0039uF, 100V, 5%, BOX	PACCOM	68392J100B5S5
12	C119,C146,C168,C195,C217,C244,C266,C293,C315,C342,C364,C391	143-33315-00	CAP, RAD PEF, 0.015uF, 100V, 5%, BOX	PACCOM	68153J100B5S5
12	C123,C148,C172,C197,C221,C246,C270,C295,C319,C344,C368,C393	143-33368-00	CAP, RAD PEF, 0.068uF, 100V, 5%, BOX	PACCOM	68683J100B5S5
12	C128,C151,C177,C200,C226,C249,C275,C298,C324,C347,C373,C396	143-33318-00	CAP, RAD PEF, 0.018uF, 100V, 5%, BOX	PACCOM	68183J100B5S5
2	D2,D1	201-54148-00	DIODE, SWITCHING, SMT, MMBD4148	VISHAY LITEON	MMBD4148
9	J1,J2,J3,J4,J5,J6,J7,J8,J9	321-02001-00	RCA JACK, 14mm QUAD, R/W	ECI	RL-1414-4LG
4	J10,J11,J12,J13	320-00512-00	CONN, WIRE TRAP, 2mm ST, 12 COND	MOLEX	52007-1210
1	J14	320-55010-00	HEADER, 2X10, SHROUDED	AMP	103309-5
1	J15	320-52208-00	HEADER, 1X8, ST, POL, LOCKRAMP	MOLEX	22-23-2081
2	M1,M2	612-18190-00	BRACKET, PC MNT SCREW TERM, 8190 (NO SCREW)	KEYSTONE	8190
43	Q1,Q2,Q3,Q4,Q5,Q6,Q7,Q8,Q9,Q10,Q11,Q12,Q13,Q14,Q15,Q16,Q17,Q18,Q19,Q20,Q21,Q22,Q23,Q24,Q25,Q26,Q27,Q28,Q29,Q30,Q31,Q32,Q33,Q34,Q35,Q36,Q37,Q38,Q39,Q40,Q41,Q42,Q43	210-53326-00	TRANS, NPN, SMT, MUTING, 2SC3326	TOSHIBA	2SC3326-B
2	Q44,Q46	211-53906-00	TRANS, NPN, SMT, MMBT3906LT1, SOT23	MOTOROLA	MMBT3906LT1
2	Q45,Q47	210-53904-00	TRANS, NPN, SMT, MMBT3904LT1, SOT23	MOTOROLA	MMBT3904LT1
72	R1,R2,R3,R4,R9,R10,R11,R12,R17,R18,R19,R20,R25,R26,R27,R28,R33,R34,R35,R36,R41,R42,R43,R44,R49,R50,R51,R52,R57,R58,R59,R60,R65,R67,R75,R76,R93,R114,R115,R132,R152,R153,R170,R191,R192,R209,R229,R230,R247,R268,R269,R286,R306,R307,R324,R345,R346,R363,R383,R384,R401,R422,R423,R440,R460,R461,R478,R499,R500,R517,R533,R537	122-31330-00	RES, SMT, 330, 5%, TF, 1/8W, 0805	PACCOM	SRM18TJ3307
17	R5,R6,R7,R8,R21,R22,R23,R24,R37,R38,R39,R40,R53,R54,R55,R56,R66	121-32200-00	RES, SMT, 20.0K, 1%, TF, 1/8W, 0805	PACCOM	SRM18TF20K7

43	R13,R14,R15,R16,R29,R30,R31,R32,R45,R46,R47,R48,R61,R62,R63,R64,R68,R82,R99,R119,R137,R159,R176,R196,R214,R236,R253,R273,R291,R313,R330,R350,R368,R390,R407,R427,R445,R467,R484,R504,R522,R534,R538	122-32270-00	RES, SMT, 2.7K, 5%, TF, 1/8W, 0805 PX-700 120V	PACCOM	SRM18TJ2.7K7
12	R70,R109,R147,R186,R224,R263,R301,R340,R378,R417,R455,R494	122-35100-00	RES, SMT, 1M, 5%, TF, 1/8W, 0805	PACCOM	SRM18TJ1M7
142	R69,R72,R78,R80,R83,R87,R94,R100,R102,R104,R106,R108,R111,R117,R120,R122,R126,R133,R138,R140,R142,R144,R146,R149,R155,R157,R160,R164,R171,R177,R179,R181,R183,R185,R188,R194,R197,R199,R203,R210,R215,R217,R219,R221,R223,R226,R232,R234,R237,R241,R248,R254,R256,R258,R260,R262,R265,R271,R274,R276,R280,R287,R292,R294,R296,R298,R300,R303,R309,R311,R314,R318,R325,R331,R333,R335,R337,R339,R342,R348,R351,R353,R357,R364,R369,R371,R373,R375,R377,R380,R386,R388,R391,R395,R402,R408,R410,R412,R414,R416,R419,R425,R428,R430,R434,R441,R446,R448,R450,R452,R454,R457,R463,R465,R468,R472,R479,R485,R487,R489,R491,R493,R496,R502,R505,R507,R511,R518,R523,R525,R527,R529,R531,R532,R535,R536,R539,R540,R541,R543,R544,R545	121-32100-00	RES, SMT, 10.0K, 1%, TF, 1/8W, 0805	PACCOM	SRM18TF10K7
156	R71,R73,R74,R79,R86,R88,R90,R92,R95,R101,R103,R105,R107,R110,R112,R113,R118,R125,R127,R128,R131,R135,R139,R141,R143,R145,R148,R150,R151,R156,R163,R165,R167,R169,R172,R178,R180,R182,R184,R187,R189,R190,R195,R202,R204,R205,R208,R211,R216,R218,R220,R222,R225,R227,R228,R233,R240,R242,R244,R246,R249,R255,R257,R259,R261,R264,R266,R267,R272,R279,R281,R282,R285,R288,R293,R295,R297,R299,R302,R304,R305,R310,R317,R319,R321,R323,R326,R332,R334,R336,R338,R341,R343,R344,R349,R356,R358,R359,R362,R365,R370,R372,R374,R376,R379,R381,R382,R387,R394,R396,R398,R400,R403,R409,R411,R413,R415,R418,R420,R421,R426,R433,R435,R436,R439,R442,R447,R449,R451,R453,R456,R458,R459,R464,R471,R473,R475,R477,R480,R486,R488,R490,R492,R495,R497,R498,R503,R510,R512,R513,R516,R519,R524,R526,R528,R530	121-31200-00	RES, SMT, 2.00K, 1%, TF, 1/8W, 0805	PACCOM	SRM18TF2K7
12	R77,R116,R154,R193,R231,R270,R308,R347,R385,R424,R462,R501	122-34330-00	RES, SMT, 330K, 5%, TF, 1/8W, 0805	PACCOM	SRM18TJ330K7
12	R81,R121,R158,R198,R235,R275,R312,R352,R389,R429,R466,R506	121-31150-00	RES, SMT, 1.50K, 1%, TF, 1/8W, 0805	PACCOM	SRM18TF1.5K7
12	R84,R123,R161,R200,R238,R277,R315,R354,R392,R431,R469,R508	121-33127-00	RES, SMT, 127K, 1%, TF, 1/8W, 0805	PACCOM	SRM18TF127K7
12	R85,R124,R162,R201,R239,R278,R316,R355,R393,R432,R470,R509	121-32147-00	RES, SMT, 14.7K, 1%, TF, 1/8W, 0805	PACCOM	SRM18TF14.7K7

12	R91,R130,R168,R207,R245,R284,R322,R361,R399,R438,R476,R515	121-30681-00	RES, SMT, 681, 1%, TF, 1/8W, 0805 PX-700 120V	PACCOM	SRM18TF681R7	
14	R89,R129,R166,R206,R243,R283,R320,R360,R397,R437,R474,R514,R542,R546	122-34100-00	RES, SMT, 100K, 5%, TF, 1/8W, 0805	PACCOM	SRM18TJ100K7	
12	R96,R134,R173,R212,R250,R289,R327,R366,R404,R443,R481,R520	122-33470-00	RES, SMT, 47K, 5%, TF, 1/8W, 0805	PACCOM	SRM18TJ47K7	
12	R97,R136,R174,R213,R251,R290,R328,R367,R405,R444,R482,R521	122-32330-00	RES, SMT, 3.3K, 5%, TF, 1/8W, 0805	PACCOM	SRM18TJ3.3K7	
6	R98,R175,R252,R329,R406,R483	122-30100-00	RES, SMT, 10, 5%, TF, 1/8W, 0805	PACCOM	SRM18TJ107	
28	U2,U4,U6,U8,U10,U12,U14,U16,U17,U18,U23,U25,U27,U33,U35,U36,U42,U44,U45,U51,U53,U54,U60,U62,U63,U69,U71,U72	221-30072-00	OPAMP, DUAL LN JFET, TL072, SMT	TEXAS INSTRUMENTS	TL072CD	
12	U19,U20,U28,U29,U37,U38,U46,U47,U55,U56,U64,U65	232-34051-00	ANALG SWTCH, SINGLE, 8 TO 1, CD4051B, SMT	TEXAS INSTRUMENTS	CD4051BM	
6	U21,U30,U39,U48,U57,U66	232-34052-00	ANALG SWTCH, DUAL, 4 TO 1, CD4052B, SMT	TEXAS INSTRUMENTS	CD4052BM	
6	U24,U32,U41,U50,U59,U68	224-33310-00	VOLUME CONTROL, STEREO, DIGITAL, CS3310, SMT	CRYSTAL	CS3310-KS	
6	U26,U34,U43,U52,U61,U70	224-09184-00	tone CONTROL, DIGITAL CONTROL, TC9184P	TOSHIBA	TC9184P	
6	U73,U74,U75,U76,U77,U78	230-30574-00	D FLIP FLOP, OCT 3STATE, 74HC574, SMT	TEXAS INSTRUMENTS	CD74HC574M	
14	U1, U3, U5, U7, U9, U11, U13, U15, U22, U31, U40, U49, U58, U67	780182	ICSA LINEAR OPA2134UA DUAL OP AMP SMT	BURR-BROWN	OPA2134UA	
801-00065-00, ASSEMBLY, PX700 AUDIO OUTPUT BOARD						
Qty	Reference Designator	Part Number	Description	Vendor	Order Number	
1		051-00065-00	SCHEMATIC, PX700 AUDIO OUTPUT BOARD			
1		071-00065-00	PARTS PLACEMENT DIAGRAM, PX700 AUDIO OUTPUT BOARD			
1		041-00065-00	ASSEMBLY DRAWING, PX700 AUDIO OUTPUT BOARD			
1		401-00065-00	PCB, PX700 AUDIO OUTPUT BOARD			
1		091-00065-00	FAB DRAWING, PX700 AUDIO OUTPUT BOARD			
24	C1,C2,C3,C7,C8,C9,C10,C11,C12,C16,C17,C18,C19,C20,C21,C25,C26,C27,C28,C29,C30,C34,C35,C36	155-20210-00	CAP, SMT CER, 0.001uF, 50V, COG 5%, 0805	PACCOM	MT102J050COG0805	
12	C4,C5,C6,C13,C14,C15,C22,C23,C24,C31,C32,C33	155-21410-01	CAP, SMT CER, 0.1uF, 50V, X7R 10%, 0805	PACCOM	MT104K050X7R0805	
6	J1,J2,J3,J4,J5,J6	321-02001-00	RCA JACK, 14mm QUAD, R/W	ECI	RL-1414-4LG	
4	J7,J8,J9,J10	320-00012-00	RIBBON HOLDER, 2mm, 12 COND	MOLEX	51048-1200	
4	J7,J8,J9,J10	460-00065-00	RIBBON CABLE, 10.25", 12 CONDUCTOR			
2	M1,M2	612-18190-00	BRACKET, PC MNT SCREW TERM, 8190 (NO SCREW)	KEYSTONE	8190	
802-00065-00 REV 03, ASSEMBLY, PX700 CONTROLLER BOARD						
Qty	Reference Designator	Part Number	Description	Vendor	Order Number	
1		052-00065-00	SCHEMATIC, PX700 CONTROLLER BOARD			
1		072-00065-00	PARTS PLACEMENT DIAGRAM, PX700 CONTROLLER BOARD			
1		042-00065-00	ASSEMBLY DRAWING, PX700 CONTROLLER BOARD			
1		402-00065-00	PCB, PX700 CONTROLLER BOARD			
1		092-00065-00	FAB DRAWING, PX700 CONTROLLER BOARD			
2	C1,C27	150-22347-00	CAP, SMT AL EL, 47uF, 16V, 20%	PANASONIC	ECE-V1CA470WR	
21	C2,C3,C8,C9,C10,C11,C12,C13,C14,C15,C16,C17,C18,C19,C20,C21,C22,C23,C24,C25,C28	155-21410-01	CAP, SMT CER, 0.1uF, 50V, X7R 10%, 0805	PACCOM	MT104K050X7R0805	
2	C5,C4	155-20018-00	CAP, SMT CER, 18pF, 50V, COG 5%, 0805	PACCOM	MT180J050COG0805	
2	C6,C26	155-20147-00	CAP, SMT CER, 470pF, 50V, COG 5%, 0805	PACCOM	MT471J050COG0805	
1	C7	150-32310-00	CAP, SMT AL EL, 10uF, 25V, 20%	PANASONIC	ECE-V1EA100SR	
2	D1,D2	200-60S1D-00	DIODE, RECT, SMT, 1A/140VRMS, S1D	VISHAY LITEON	S1D	
1	D3	205-70200-00	DIODE, TVS, 600W, UNI-DIR, 20V, SMT	MOTOROLA	1SMB20AT3	
2	D5,D4	700150	DIODE, TVS, 600W, BI-DIR, 11.0V, SMT	ON SEMI	P6SMB11CAT3	ECN3151
1	D6	201-54148-00	DIODE, SWITCHING, SMT, MMBD4148	VISHAY LITEON	MMBD4148	
5	FL1,FL2,FL3,FL4,FL5	190-60310-00	EMI FILTER, SMT, 10000pF	PANASONIC	EXCCET103U	

1	F1	690-01000-00	FUSE HOLDER, 5X20mm PC MNT, BAYONET	BUSSMANN	HBH-M	
1	J1	320-55010-00	HEADER, 2X10, SHROUDED PX-700 120V	AMP	103309-5	
2	J2,J4	321-20000-00	PHONE JACK, 3.5mm, MONO, SB	A/D ELECTRONICS	3507-10	
1	J3	320-55013-00	HEADER, 2X13, ST, SHROUDED	AMP	103309-6	
1	J5	323-00004-00	CONN, TERM BLK, PLG, PCRA, 4 PIN	WIELAND	25.332.3453.1	
1	J6	320-55007-00	HEADER, 2X7, ST, SHROUDED	AMP	103309-2	
1	J7	320-55005-00	HEADER, 2X5, SHROUDED	AMP	103309-1	
1	J8	320-52204-00	HEADER, 1X4, ST, POL, LOCKRAMP	MOLEX	22-23-2041	
1	J11	320-56010-00	HEADER, 1X10, ST, POL, SHROUDED, 2mm	JST	B10B-PH-K	
1	J12	320-52003-00	HEADER, 1X3	SAMTEC	TSW-103-07-G-S	
1	K1	308-00005-00	RELAY, PCNPSS, 2 FORM C, 5V	OMRON	G5V-2-DC5	
2	M1,M2	612-18190-00	BRACKET, PC MNT SCREW TERM, 8190 (NO SCREW)	KEYSTONE	8190	
1	P1	327-01009-00	CONN, DSUB, RA, RECEP, 9 PIN	AMP	745781-4	
1	Q1	211-53906-00	TRANS, NPN, SMT, MMBT3906LT1, SOT23	MOTOROLA	MMBT3906LT1	
2	Q2,Q3	210-53904-00	TRANS, NPN, SMT, MMBT3904LT1, SOT23	MOTOROLA	MMBT3904LT1	
1	R1	122-33150-00	RES, SMT, 15K, 5%, TF, 1/8W, 0805	PACCOM	SRM18TJ15K7	
1	R2	122-32330-00	RES, SMT, 3.3K, 5%, TF, 1/8W, 0805	PACCOM	SRM18TJ3.3K7	
2	R3,R10	122-34100-00	RES, SMT, 100K, 5%, TF, 1/8W, 0805	PACCOM	SRM18TJ100K7	
7	R4,R11,R12,R17,R18,R19,R20	122-33100-00	RES, SMT, 10K, 5%, TF, 1/8W, 0805	PACCOM	SRM18TJ10K7	
6	R5,R6,R7,R8,R9,R13	122-32100-00	RES, SMT, 1K, 5%, TF, 1/8W, 0805	PACCOM	SRM18TJ1K7	
2	R16,R14	122-32150-00	RES, SMT, 1.5K, 5%, TF, 1/8W, 0805	PACCOM	SRM18TJ1.5K7	
1	R15	122-31120-00	RES, SMT, 120, 5%, TF, 1/8W, 0805	PACCOM	SRM18TJ1207	
1	U1	254-40707-00	RESET IC, MAX707, SMT	MAXIM	MAX707CSA	
1	U2	250-10552-00	MICROPROC, 80C552, 16MHz, PLCC68	PHILLIPS	S80C552-4A68	
1	U3	230-30573-00	LATCH, OCTAL, TRI STATE, 74HC573, SMT	TEXAS INSTRUMENTS	CD74HC573M	
1	U5	260-03012-00	SRAM, NON VOLATILE, DS1230Y-120	DALLAS	DS1230Y-120	
1	U6	230-30541-00	BUFFER, OCTAL, TRI STATE, 74HC541, SMT	TEXAS INSTRUMENTS	CD74HC541M	
1	U7	230-30000-00	NAND GATE, QUAD, 2 IN, 74HC00, SMT	TEXAS INSTRUMENTS	CD74HC00M	
2	U8,U10	230-30138-00	DECODER, 3 TO 8, 74HC138, SMT	TEXAS INSTRUMENTS	CD74HC138M	
2	U9,U16	230-30014-00	SCHMIDT TRIGGER, INVERTING, HEX, 74HC14, SMT	TEXAS INSTRUMENTS	CD74HC14M	
1	U11	230-30245-00	BUS TRANCVR, OCTAL, NON INV, TRI STATE, 74HC245, SMT	TEXAS INSTRUMENTS	CD74HC245M	
2	U14,U12	270-00485-00	INTRFC, BUS TRANS, RS485, LTC485	LINEAR TECHNOLOGY	LTC485CN8	
1	U13	270-32321-00	INTRFC, BUS TRANS, DUAL RS232, MAX232A, SMT	MAXIM	MAX232ACWE	
1	U15	271-30211-00	OPTOISOLATOR, MOC211, SOIC8	QT OPTOELECTRONICS	MOC211-M	
1	Y1	345-11059-00	XTAL, HC49, 11.0592MHz	CTS	MP111	
1	U5	328-02028-00	SOCKET, 0.600" DIP DLTST, 28 PIN	AMP	2-640362-3	
1	U4	328-02032-00	SOCKET, 0.600" DIP DLTST, 32 PIN	AMP	2-644018-3	
1	U2	328-10168-00	SOCKET, PLCC, TSM, 68 PIN	THOMAS AND BETTS	PCS-068SMU-11	
2	U12, U14	328-00008-00	SOCKET, 0.300" DIP DLTST, 8 PIN	AMP	2-640463-3	
1	U4	900-00065-01	PROGRAMMED EPROM, PX-700, V1.10		CKSUM#- 01810B96	SCN316
1		262-01212-00	UNPROGRAMMED EPROM 64K X 8	AMD	27C512-120DC	
			EQUIVALENT	SGS	M27C512-12F1	ECN3251
1		910-00065-01	SOFTWARE, PX-700, V1.10		V110.HEX	SCN316

803-00065-00 REV 02, ASSEMBLY, PX700 IR OUTPUT BOARD

Qty	Reference Designator	Part Number	Description	Vendor	Order Number	
1		053-00065-01	SCHEMATIC, PX700 IR OUTPUT BOARD			
1		073-00065-00	PARTS PLACEMENT DIAGRAM, PX700 IR OUTPUT BOARD			
1		043-00065-00	ASSEMBLY DRAWING, PX700 IR OUTPUT BOARD			ECN3124
1		403-00065-00	PCB, PX700 IR OUTPUT BOARD			
1		093-00065-00	FAB DRAWING, PX700 IR OUTPUT BOARD			
9	C1,C2,C3,C4,C5,C6,C7,C8,C15	155-20147-00	CAP, SMT CER, 470pF, 50V, COG 5%, 0805	PACCOM	MT471J050COG0805	
5	C9,C10,C11,C12,C16	155-21410-01	CAP, SMT CER, 0.1uF, 50V, X7R 10%, 0805	PACCOM	MT104K050X7R0805	
2	C14,C13	150-32310-00	CAP, SMT AL EL, 10uF, 25V, 20%	PANASONIC	ECE-V1EA100SR	
9	J1,J2,J3,J4,J5,J6,J7,J8,J9	321-20000-00	PHONE JACK, 3.5mm, MONO, SB	A/D ELECTRONICS	3507-10	
1	J10	320-52003-00	HEADER, 1X3	SAMTEC	TSW-103-07-G-S	
1	J11	320-55105-00	HEADER, 2X5, RA, SHROUDED	AMP	103311-1	
2	M1,M2	612-18190-00	BRACKET, PC MNT SCREW TERM, 8190 (NO SCREW)	KEYSTONE	8190	
9	Q1,Q2,Q5,Q6,Q9,Q10,Q13,Q14,Q17	211-53906-00	TRANS, NPN, SMT, MMBT3906LT1, SOT23	MOTOROLA	MMBT3906LT1	
9	Q3,Q4,Q7,Q8,Q11,Q12,Q15,Q16,Q18	210-53904-00	TRANS, NPN, SMT, MMBT3904LT1, SOT23	MOTOROLA	MMBT3904LT1	

36	R1,R2,R3,R4,R5,R6,R7,R8,R11,R12,R13,R14,R15,R16,R17,R18,R21,R22,R23,R24,R25,R26,R27,R28,R31,R32,R33,R34,R35,R36,R37,R38,R41,R42,R44	122-32100-00	RES, SMT, 1K, 5%, TF, 1/8W, 0805 PX-700 120V	PACCOM	SRM18TJ1K7	
9	R9,R10,R19,R20,R29,R30,R39,R40,R46	122-34100-00	RES, SMT, 100K, 5%, TF, 1/8W, 0805	PACCOM	SRM18TJ100K7	
2	R43,R47	122-33100-00	RES, SMT, 10K, 5%, TF, 1/8W, 0805	PACCOM	SRM18TJ10K7	
1	R45	122-31100-00	RES, SMT, 100, 5%, TF, 1/8W, 0805	PACCOM	SRM18TJ1007	
2	U1,U2	230-30002-00	NOR GATE, QUAD 2 IN, 74HC02, SOIC14N	TEXAS INSTRUMENTS	CD74HC02M	
1	U3	230-50004-00	INVERTER, NC7S04, SOT23-5	FAIRCHILD	NC7S04M5	
1	U4	230-30138-00	DECODER, 3 TO 8, 74HC138, SOIC16N	TEXAS INSTRUMENTS	CD74HC138M	
1	J10 between pins 1 and 2 "Flasher" position.	667-2236-000	CONN JUMPER .1 SHORTING PLUG	3M/ISD	929950-00	ECN3124
1		TF063 REV 02 -	MISC PX700 BD TESTS USING TF063 FIXTURE- 1/29/2002			ECN3306
804-00065-00 rev 01, ASSEMBLY, PX700 TRIGGER OUTPUT BOARD						
Qty	Reference Designator	Part Number	Description	Vendor	Order Number	
1		054-00065-00	SCHEMATIC, PX700 TRIGGER OUTPUT BOARD			
1		074-00065-00	PARTS PLACEMENT DIAGRAM, PX700 TRIGGER OUTPUT BOARD			
1		044-00065-00	ASSEMBLY DRAWING, PX700 TRIGGER OUTPUT BOARD			
1		404-00065-00	PCB, PX700 TRIGGER OUTPUT BOARD			
1		094-00065-00	FAB DRAWING, PX700 TRIGGER OUTPUT BOARD			
11	C1,C2,C3,C5,C6,C7,C8,C9,C10,C11,C14	155-21410-01	CAP, SMT CER, 0.1uF, 50V, X7R 10%, 0805	PACCOM	MT104K050X7R0805	
1	C4	150-42310-00	CAP, SMT AL EL, 10uF, 35V, 20%	PANASONIC	ECE-V1VA100SR	
2	C13,C12	150-32310-00	CAP, SMT AL EL, 10uF, 25V, 20%	PANASONIC	ECE-V1EA100SR	
8	D1,D2,D3,D4,D5,D6,D7,D8	200-60S1D-00	DIODE, RECT, SMT, 1A/140VRMS, S1D	VISHAY LITEON	S1D	
9	J1,J2,J3,J4,J5,J6,J7,J8,J9	321-20000-00	PHONE JACK, 3.5mm, MONO, SB	A/D ELECTRONICS	3507-10	
1	J10	320-55107-00	HEADER, 2X7, RA, SHROUDED	AMP	103311-2	
2	M1,M2	612-18190-00	BRACKET, PC MNT SCREW TERM, 8190 (NO SCREW)	KEYSTONE	8190	
7	Q1,Q3,Q5,Q7,Q9,Q11,Q13	211-53906-00	TRANS, NPN, SMT, MMBT3906LT1, SOT23	MOTOROLA	MMBT3906LT1	
7	Q2,Q4,Q6,Q8,Q10,Q12,Q14	210-53904-00	TRANS, NPN, SMT, MMBT3904LT1, SOT23	MOTOROLA	MMBT3904LT1	
1	RV1	381-00020-00	PTC, 0.20amp	RAYCHEM	RXE020-2	
23	R1,R3,R4,R6,R7,R9,R10,R11,R12,R15,R16,R17,R19,R20,R21,R23,R24,R25,R27,R28,R29,R31,R32	122-33100-00	RES, SMT, 10K, 5%, TF, 1/8W, 0805	PACCOM	SRM18TJ10K7	
9	R2,R5,R8,R13,R14,R18,R22,R26,R30	122-32100-00	RES, SMT, 1K, 5%, TF, 1/8W, 0805	PACCOM	SRM18TJ1K7	
1	U1	230-30004-00	INVERTER, HEX, 74HC04, SOIC14	TEXAS INSTRUMENTS	CD74HC04M	
2	U2,U3	271-30211-00	OPTOISOLATOR, MOC211, SOIC8	QT OPTOELECTRONICS	MOC211-M	
1		TF063 REV 02 -	MISC PX700 BD TESTS USING TF063 FIXTURE- 1/29/2002			ECN3306
805-00066-00 rev 02, ASSEMBLY, PX700 POWER SUPPLY BOARD, 120V						
Qty	Reference Designator	Part Number	Description	Vendor	Order Number	
1		055-00065-00	SCHEMATIC, PX700 POWER SUPPLY BOARD			
1		075-00065-00	PARTS PLACEMENT DIAGRAM, PX700 POWER SUPPLY BOARD			
1		045-00065-00	ASSEMBLY DRAWING, PX700 POWER SUPPLY BOARD			
1		405-00065-00	PCB, PX700 POWER SUPPLY BOARD			
1		095-00065-00	FAB DRAWING, PX700 POWER SUPPLY BOARD			
8	C3,C5,C7,C9,C11,C13,C15,C16	135-22410-00	CAP, AX CER, 0.1uF 50V, Z5U 20%	KEMET	C410C104M5U5CA	
5	C2,C6,C8,C12,C18	140-32347-00	CAP, RAD AL EL, 47uF, 25V, 20%	PACCOM	EVR47M25AA7	
2	C4,C10	140-22547-00	CAP, RAD AL EL, 4700uF, 16V, 20%	PANASONIC	ECA1CM472	
1	C17	140-32547-00	CAP, RAD AL EL, 4700uF, 25V, 20%	PANASONIC	ECA1EM472	
2	D1,D2	203-34005-00	BRIDGE RECT, 4A, 50V	VISHAY LITEON	KBJ4005G	
				VISHAY LITEON	KBJ401G	ECN2697
1	D3	200-14003-00	DIODE, RECT, 1A, 1N4003	DIODES INC	1N4003 T&R	
4	F1,F2	690-00501-00	FUSE CLIP, 5mm PC MNT, 111-501	LITTELFUSE	111 501	
1	J1	320-52208-00	HEADER, 1X8, ST, POL, LOCKRAMP	MOLEX	22-23-2081	

1	J2	320-52204-00	HEADER, 1X4, ST, POL, LOCKRAMP	MOLEX	22-23-2041	
1	J6	320-52605-00	HEADER, 1X5, ST, POL, LOCKRAMP, 0.156x700 120V	JST	B5P-VH	
5	J4,J5,J7,J8,J9	324-01021-00	CONN, QC PC MALE, 0.250"	ZIERICK	1021	
1	J3	320-52205-00	HEADER, 1X5, ST, POL, LOCKRAMP	MOLEX	22-23-2051	
1	K1	308-15012-00	RELAY, PC NPSS TYPE 1, 12V	OEG	SDT-SS-112DM	
2	JP1, JP3	101-10000-00	JUMPER, 0.300"	ECI	R1JRJ000.00	
		EQUIVALENT		PACCOM	SRD25TZERO OHM	
1	Q1	210-03904-00	TRANS, NPN, 2N3904	NATIONAL	2N3904	
2	RV1	191-04250-00	MOV, RAD DISC, 14mm, 250V	HARRIS	V250LA20A	
1	R1	101-12100-00	RES, AXIAL, 1.0K, 5%, CF, 1/8W	PACCOM	SRD25TJ1.0K	
1	R2	101-30470-00	RES, AXIAL, 47 Ohm, 5%, CF, 1/4W	PACCOM	RD25TJ47	
2	U1,U5	220-27805-00	VREG, TO-220 IN, +5V, 7805	NJR	NJM7805FA	
1	U2	220-27806-00	VREG, TO-200 IN, +6V, 7806	NJR	NJM7806FA	
1	U3	220-27905-00	VREG, TO-220 IN, -5V, 7905	NJR	NJM7905FA	
1	U4	220-27906-00	VREG, TO-220 IN, -6V, 7906	NJR	NJM7906FA	
10	U1, U2, U3, U4, U5	700-06021-00	HEATSINK, TO-220, 6021	THERMALLOY	6021PB	
5	U1, U2, U3, U4, U5	600-10003-00	SCREW, MCH PH PN ZNC, 4-40X0.375"	ANY VENDOR		
5	U1, U2, U3, U4, U5	610-10100-00	NUT, 4-40, KEP	ANY VENDOR		
1	U5	750-20058-00	HEATSINK PAD, TO-220 (SILPAD)	BERQUIST	SP600-58	
1		TF063 REV 02 -	MISC PX700 BD TESTS USING TF063 FIXTURE- 1/29/2002			ECN3306
80C-00065-00 REV 03, ASSEMBLY, PX700 POWER INLET BOARD						
Qty	Reference Designator	Part Number	Description	Vendor	Order Number	
1		05C-00065-00	SCHEMATIC, PX700 POWER INLET BOARD			
1		07C-00065-00	PARTS PLACEMENT DIAGRAM, PX700 POWER INLET BOARD			
1		04C-00065-01	ASSEMBLY DRAWING, PX700 POWER INLET BOARD			
1		40C-00065-00	PCB, PX700 POWER INLET BOARD			
1		09C-00065-00	FAB DRAWING, PX700 POWER INLET BOARD			
1	J5	325-20580-00	CONN, AC, IEC320, PC MNT, FLANGED	GLOB TEK	PX0580/PC	
2	J1,J2	324-01021-00	CONN, QC PC MALE, 0.250"	ZIERICK	1021	
1	C1	143-68410-00	CAP, RAD PEF, 0.1uF, 250V, 20%, X RATED	PANASONIC	ECQ-U2A104MV	
1		457-00065-00	WIRE ASS'Y, 4.00", GRN/YEL, 18AWG, RT/ST	DICON	DWG# C000006A	ECN3265
806-00065-00 (REV 02), ASSEMBLY, PX700 FRONT PANEL BOARD						
Qty	Reference Designator	Part Number	Description	Vendor	Order Number	
1		056-00065-01	SCHEMATIC, PX700 FRONT PANEL BOARD			ECN2749
1		076-00065-00	PARTS PLACEMENT DIAGRAM, PX700 FRONT PANEL BOARD			
1		046-00065-00	ASSEMBLY DRAWING, PX700 FRONT PANEL BOARD			
1		406-00065-00	PCB, PX700 FRONT PANEL BOARD			
1		096-00065-00	FAB DRAWING, PX700 FRONT PANEL BOARD			
1	C1	155-20210-00	CAP, SMT CER, 0.001uF, 50V, COG 5%, 0805	PACCOM	MT102J050COG0805	
1	C5,C2	150-42233-00	CAP, SMT AL EL, 3.3uF, 35V, 20%	PANASONIC	ECE-V1VS3R3SR	
4	C3,C7,C8,C10	150-22310-00	CAP, SMT AL EL, 10uF, 16V, 20%	PANASONIC	ECE-V1CS100SR	
3	C4,C9,C11	155-21410-01	CAP, SMT CER, 0.1uF, 50V, X7R 10%, 0805	PACCOM	MT104K050X7R0805	
1	C6	155-21310-01	CAP, SMT CER, 0.01uF, 50V, X7R 10%, 0805	PACCOM	MT103K050X7R0805	
1	D4	209-00516-00	PHOTODIODE, IR, LTR516AB	LITEON	LTR516AB	ECN2749
1	D5	204-15570-00	LED, BI-COLOR, T1, 3.1mm, Y/G (570 nm) and R (630 nm)	STANLEY	VRPY3312X	
1	J1	320-56110-00	HEADER, 1X10, RA, POL, SHROUDED, 2mm	JST	S10B-PH-K	
1	J2	320-56105-00	HEADER, 1X5, RA, POL, SHROUDED, 2mm	JST	S5B-PH-K	
2	R11	122-31100-00	RES, SMT, 100, 5%, TF, 1/8W, 0805	PACCOM	SRM18TJ1007	
3	R1,R2,R3,R5	122-32100-00	RES, SMT, 1K, 5%, TF, 1/8W, 0805	PACCOM	SRM18TJ1K7	
3	R4,R12	122-33100-00	RES, SMT, 10K, 5%, TF, 1/8W, 0805	PACCOM	SRM18TJ10K7	
1	R7	122-33470-00	RES, SMT, 47K, 5%, TF, 1/8W, 0805	PACCOM	SRM18TJ47K7	
1	R8	122-30100-00	RES, SMT, 10, 5%, TF, 1/8W, 0805	PACCOM	SRM18TJ107	
1	R10	122-31180-00	RES, SMT, 180, 5%, TF, 1/8W, 0805	PACCOM	SRM18TJ1807	
1	S1	300-03200-00	SWITCH, PC, SPST MOM, E320E1-1, BLACK CAP	E-SWITCH	E320E1-1 (BLACK)	
1	U1	272-13373-00	IR AMPLIFIER/DETECTOR, MC3373P	MOTOROLA	MC3373P	
1	U2	272-05380-00	IR RECEIVER, 38kHz, W/CLIP, TFMT 5380	TEMIC	TFMT 5380	
2	U3,U4	230-50004-00	INVERTER, NC7S04, SOT23-5	FAIRCHILD	NC7S04M5	
1	D5	640-90350-00	SPACER, LED, TRILEAD, 0.350"	KEYSTONE	8913	

1		TF063 REV 02 -	MISC PX700 BD TESTS USING TF063 FIXTURE- 1/29/2002			ECN3306
			PX-700 120V			
80A-00065-00, ASSEMBLY, PX700 RS232 INPUT BOARD						
Qty	Reference Designator	Part Number	Description	Vendor	Order Number	
1		05A-00065-00	SCHEMATIC, PX700 RS232 INPUT BOARD			
1		07A-00065-00	PARTS PLACEMENT DIAGRAM, PX700 RS232 INPUT BOARD			
1		04A-00065-00	ASSEMBLY DRAWING, PX700 RS232 INPUT BOARD			
1		40A-00065-00	PCB, PX700 RS232 INPUT BOARD			
1		09A-00065-00	FAB DRAWING, PX700 RS232 INPUT BOARD			
1	J1	321-21000-00	PHONE JACK, 3.5mm, STEREO, SB, NO THREAD	A/D ELECTRONICS	3061-50	
1	J2	320-56005-00	HEADER, 1X5, ST, POL, SHROUDED, 2mm	JST	B5B-PH-K	
80B-00065-01, ASSEMBLY, PX700 POWER SWITCH BOARD						
Qty	Reference Designator	Part Number	Description	Vendor	Order Number	
1		05B-00065-00	SCHEMATIC, PX700 POWER SWITCH BOARD			
1		400-05006-00	PCB, POWER SWITCH BD REV 00			
1	SW101	300-00410-00	SWITCH, PC / PANEL, SPST LATCH, KDC-A04A-10-B	TECX	KDC-A04-10A (B)-B1-E	
2	P101, P102	324-00901-00	CONN, QC PC RA MALE, 0.250"	ZIERICK	901	
Rev	Description of change	Date				
00	Original	4/20/2000				
01	Changed: BOM rev to 01, Item 120 from 470-00066-00 to 470-00066-01(safety label), Item 230 from 370-00065-00 to 370-00065-01(transformer), Item 2600 (690) from 440-00065-00 to 440-00065-01(die cut adhesive), Item 350 from 610-40100-00 to 610-40200-00 (KEP to Nylock), Item 2640 (730) from 450-00065-00 to 450-00065-01 (FP cable). Added: Item 475 473-00066-00 (fuse label), Item 476 923-00066-00 (fuse label art).	5/4/2000				
02	On 805-00066-00- power supply bd ass'y- Added new mfg part number for 203-34005-00 BRIDGE RECT, 4A, 50V. The equivalent, which should be bought under the same part number is: VISHAY LITEON (Diodes Inc.) KBJ401G 3- Manufacturing/Purchasing/QA Note: a) The affected BOM is rev'd to b) The approved vendor (Carlton) notified via email. c) The equivalent Mfg's part number has been added to the parts master comment field.	6/7/2000				

03	<p>The changes suggested are required to pass the CSA safety requirements. Except for the Op-amp change which is to improve performance.</p> <p>Changes to 800-00065-01, ASSEMBLY, PX700 AUDIO BOARD:</p> <p>Remove 14 OPAMP, DUAL LN JFET, TL072, SMT part number 221-30072-00 (U1, 3,5,7,9,11,13,15,22,31,40,49,58,67).</p> <p>Final Assembly changes:</p> <p>Remove ground wire 456-00065-01 WIRE ASS'Y, 3.00", GRN/YEL, 18AWG, 0.250" FF/RT</p> <p>Add additional ground wire 457-00065-00 WIRE ASS'Y, 4.00", GRN/YEL, 18AWG, RT/ST (total of 2 on final assembly)</p> <p>Add label 474-00065-00 LABEL, CHASSIS GROUND to final assembly.(NEW PART)</p> <p>ON 80B-00065-00- POWER SWITCH BD ASS'Y Order number change:</p> <p>Change order number on part number 300-00410-00 from KDC-A04-10-B, B2 to KDC-10A(B)-B1-E (Carlton part) ON 80C-00065-00 POWER INLET BD ASS'Y-</p> <p>Remove quick connect 324-01021-00 @ j3 - 1pc</p> <p>Print Changes Required:</p> <p>On the assembly drawings add the chassis ground label and change the chassis ground wire to the power entry</p>	8/1/2000	PX-700 120V			
04	Replaced 370-00065-01 w/ 370-00065-02 due to hole spec/detail revision.					
05	<p>806-00065-00 changed manufacturer's P/N for PHOTODIODE-</p> <p>REMOVE 209-00526-00 LITEON LTR-526AB from assembly number 806-00065-00 (D4).</p> <p>ADD 209-00516-00 LITEON LTR-516AB to assembly number 806-00065-00 (D4).</p>	10/2/2000				
06	On 80D-00065-00 changed switch cap 430-05000-00 to new design 430-00065-00	10/12/2000				
07	On 808-00066-00- rev'd chassis fab dwg 410-00066-00 to 01 to reflect artwork change to rear panel	1/2/2001				
08	On 808-00066-00-Change quantity of P/N 457-00065-00 (WIR 4" GRN/YEL 18AWG RT/ST ASSY) from 2 pieces to 1	1/12/2001				
09	ON PX-700 120V -added 801-3350-000 bag- 1pc	1/26/2001				
10	Moved 900-00065-00 v1.0 EPROM from final ass'y to controller bd ass'y	4/10/2001				
11	900-00065-01 replaces 900-00065-00 on Controller bd	6/28/2001				
12	<p>Moved 457-00065-00- 1pc to 80C-00065-00</p> <p>Added jumper 667-2236-000 to 803-00065-00 IR Output bd</p>	2/22/2002				

13	Replaced 205-70050-00 diode w/ 700150 on 802-0005-00 controller bd	3/12/2002	PX-700 120V			
14	Revised wiring dwg C000006 on 80C-00065-00	7/24/2002				
15	Revised and added test specs on IR Output, Trigger I/O, Power Supply, and Front panel board BOMs	9/6/2002				

Installation Manager V3.0 Quick Guide

1.0 Quick Start

- Installation Manager v3.0 is **required** for programming PX-700s with v2.0 or higher firmware.
- Download IMv3.0Setup.exe and run to install Installation Manager v3.0.
- The first time Installation Manager v3.0 is run, the existing library.aal file will be automatically converted to a library.aal3 file, the IR Library format used by v3.0. The library.aal file will not be affected.
- IR codes that are not recognized in the converted Library should be re-learned.
- When using Installation Manager v3.0 with PX-700s equipped with v1.0 or v1.10 firmware, deselect the "Enable download of optimized IR codes" Project Preference and download 'As Learned' format IR codes.
- When using v3.0 with PX-700s equipped with v2.0 or higher firmware, select the "Enable download of optimized IR codes" Preference and download 'Variable Length Optimized' format IR codes.
- Use Model Properties to change the Carrier Frequency and Number of Repeats of Variable Length Optimized format IR codes.
- IR codes used in a Project that are different than IR Library codes with the same model and name are detected when the Project is downloaded and can be updated with those from the IR Library if desired.
- Denon IR codes, satellite receiver IR codes from some manufacturers, and codes from some Pioneer remotes require special treatment. See the Problems and Solutions section for more information.

1.1 Overview

While backward compatible with all versions of PX-700 firmware, Installation Manger v3.0 is specifically designed to work with PX-700 firmware v2.0, and together they offer improved performance of IR learning and IR control of sources.

- IR Code Carrier frequency can be set to any value between 10kHz and 57kHz.
- Number of repeats of an IR Code can be specified from 1 to 15.
- Many IR Code protocols are recognized and learned IR Codes are adjusted to match known protocols.
- The number of unique IR Codes that can be downloaded to the PX-700 has been increased from 175 to over 230.
- IR codes for a Model that is used with more than one Source are downloaded only once.
- All Projects and IR Libraries created with previous versions of Installation Manager will work with v3.0.
- Installation Manager v3.0 will work with older versions of PX-700 firmware, however, adjustable Carrier Frequency, Number of Repeats, and increased IR Code storage require v2.0 PX-700 firmware.
- Projects created or saved when using installation Manger v3.0 cannot be opened by older versions of Installation Manager.
- PX-700 v2.0 or higher firmware **requires** Installation Manager v3.0. Older versions of Installation Manager **will not** work with PX-700s that have v2.0 firmware. All PX-700s starting at Serial Number XXXXXX have v2.0 or higher firmware.

1.2 Installation

- If you have previously installed Installation Manager on your computer, do not Uninstall the older version before installing v3.0. During the installation of v3.0, make sure you select the same folder in which you previously installed Installation Manager as the location in which to install v3.0. During the installation, you will be asked if you want to create backup copies of files that are replaced and you should respond 'Yes' to back up the older version of Installation Manager. Existing Project Files and IR Libraries will not be affected.
- Download IMv3.0Setup.exe from the Audioaccess Technical Services website.
- Run IMv3.0Setup.exe. This will install Installation Manager v3.0 on your computer.

1.3 IR Library Conversion

Older versions of Installation Manager use a file called 'library.aal' to store the IR codes you learn. Installation Manager v3.0 uses a new file called 'library.aal3'.

- The first time Installation Manager v3.0 is run on your computer, it will attempt to locate and convert an existing 'library.aal' file to 'library.aal3'. If it finds a library.aal file in the same folder as the executable (Audioaccess.exe), you will be prompted to confirm the conversion of the Library. Click 'Ok'. The library.aal file will not be affected by the conversion. Note: If you select 'Cancel', your Library will not be converted and a blank aal3 library will be created. Also, if a library.aal file is not found in the same folder as the executable, a blank aal3 library will be created.
- After the conversion is complete, a dialog is displayed with information about the models found and codes converted. If any codes are not recognized, the message will say that XX codes are undefined.
- An unrecognized code is indicated by a red question mark superimposed over the 'remote' icon next to the code name in the Library window.
- A code can be unrecognized for two reasons: it is in an unknown IR code protocol or the learned code was captured in a way that keeps its protocol from being recognized. If all the codes for a model are unrecognized, it usually means that they are in an unknown IR code protocol. If only some of the codes in a model are unrecognized, there is usually a problem with those codes and they should be relearned. See **Managing IR Codes** for more information.
- Even if a code is unrecognized, it will still control the device when used in "As Learned" format. However, if a code is in a protocol that can be recognized, it will not be optimized correctly and 128 Byte Optimized and Variable Length Optimized format versions of the code will not control the device. See the **IR Code Formats** and **Problems and Solutions** sections for more information.
- Some manufacturers' IR codes require special treatment. See the **Problems and Solutions** and **Tips and Techniques** sections for more information.
- Test the codes in the converted library. Do not wait until you are at a job site to find and correct problems with the converted IR codes.

2.0 IR Library

The IR Library is used to store IR codes used with the PX-700. It is organized hierarchically into Categories, Brands, Models, and IR codes. IR codes are stored in Models. IR codes may be learned or imported from an existing library.

2.1 Categories, Brands, and Models

- To add a new Category, right click on an existing Category and select **Add Category** from the pop up menu. Enter the name of the new Category.
- To add a new Brand to an existing Category, right click on the Category or on any Brand in that Category. Select **Add Brand** and enter the name of the new Brand.
- To add a new Model to an existing Brand, right click on the Brand and select **Add Model**.
 - The Model/IR Code Properties dialog will open.
 - Enter the Model's name.
 - If you know the specific Carrier Frequency used to modulate the IR codes for this Model, click the down arrow and select the frequency from the list, otherwise leave the value set to 38kHz.
 - If you know that the Model requires more than one repeat to be successfully controlled, select the desired number of repeats from the Play/Repeat IR codes pull down list, otherwise leave the value set to 1 time.
 - The Carrier Frequency and Number of Repeats settings will apply to all IR codes for the Model, but they are only used with Variable Length Optimized format. See the **Problems and Solutions** and **Tips and Techniques** sections for more information about Carrier Frequencies and Number of Repeats.
 - When you've finished editing the new Model's properties, click 'Ok'.
- Categories, Brands, and Models can be Deleted. IR Codes can be Cut, Copied, and Pasted or Deleted. Right click on the entry and select the desired operation from the pop up menu.

2.2 IR Code Formats

There are three different versions of each IR code stored in the IR Library: As Learned, 128 Byte Optimized, and Variable Length Optimized. Installation Manager processes As Learned codes to automatically create the other two versions.

- As Learned codes are just that, codes exactly as they are learned. They are stored in the PX-700 in a 128 byte format and are used with PX-700 firmware v1.0 and v1.10. This is the same format that is used to store codes in a library.aal file. These codes are always played out with the a carrier frequency of 38kHz.
- 128 Byte Optimized format codes are intended to be used with PX-700 firmware v1.0 and v1.10. They have been trimmed to one repeat of the code and if they are in a known IR code protocol, they have been further processed to exactly match the protocol. These codes are stored in the PX-700 in exactly the same way as As Learned codes and are also played out with a 38kHz carrier frequency.
- Variable Length Optimized codes are stored in the PX-700 in a format that is only compatible with PX-700 firmware v2.0 and higher. These codes include information about the carrier frequency and number of repeats and use less PX-700 memory than 128 byte codes. If they are in a known IR code protocol, they have been further processed to exactly match the protocol.
- When an IR code is used in a Project, all three versions of each IR code are automatically copied to the Project.
- The IR code format that is downloaded to the PX-700 when a Project is downloaded is determined by the Project's Preferences and the firmware version in the PX-700.
 - If "Enable download of optimized IR codes" is not selected, Installation Manager will download As Learned codes to the PX-700. This is the best Preferences setting to use if the PX-700 has v1.0 or v1.10 firmware.
 - If "All connected PX-700s have v1.10 or higher firmware?" is not selected *and* "Enable download of optimized IR codes" is selected, Installation Manager will download 128 Byte Optimized codes to the PX-700.
 - If both "All connected PX-700s have v1.10 or higher firmware?" and "Enable download of optimized IR codes" are selected, Installation Manager will attempt to download Variable Length Optimized codes to the PX-700. The PX-700 must have v2.0 or higher firmware and this is the best Preferences setting to use if the PX-700 does have v2.0 or higher firmware.

2.3 Learning an IR Code

- Connect the PX-700 to the computer using a standard (not null modem) Male/Female 9 pin serial cable or an Audioaccess PC Link cable. Turn on the PX-700 and wait for the front panel LED to turn from red to green and back to red.
- Right Click on the Model whose codes are to be learned and select Manage IR codes from the pop up menu.
- After the Manage IR Codes dialog opens, select the Learn Tab.
- Click in the box next to Engage Learning Mode.
- Point the Model's remote control at the window on the front of the PX-700 (from a distance of 2 to 3 inches) and press and hold down the button that corresponds to the code being learned. Release the button when the computer beeps.
- If a code was learned successfully, Installation Manager will process the code and attempt to recognize the IR Code protocol. If the protocol is known and the code is recognized, the protocol type and the code's data will be displayed below the IR Code Name. If 'unknown' appears, the code is in an unknown protocol or the data transferred from the PX-700 when the code was captured does not allow the code to be recognized by Installation Manager. One way to tell this second case has occurred is if other codes from the same remote were recognized. Click Learn Again and relearn 'unknown' codes that should have been recognized. See Tips and Techniques for a partial list of manufacturers whose protocols are known.
- If an IR code is recognized and the Carrier Frequency specified in the Model's Properties does not match the carrier frequency associated with the recognized protocol, a dialog opens asking if you want to change the Model Properties to the protocol's carrier frequency. Click Yes.
- If the code was learned successfully, test the code several times (See Testing an IR Code for more information). If the code works, enter a name for the code and click Save.
- If the code was not learned successfully, relearn the code.
- When all the Model's codes have been learned and tested, deselect Engage Learning Mode, change to a different Tab, or close the Manage IR Codes dialog.

2.4 Testing an IR Code

All codes learned to the IR Library should be tested to ensure that they work properly. Installation Manager allows for testing IR Codes in each of the three formats (As Learned, 128 Byte Optimized, and Variable Length Optimized). Because of the way in which various devices respond to IR control, it is possible that IR Codes that control a device in one format might not in the other formats and so it is important to test codes in each format, primarily to gain understanding of how the device being controlled behaves.

- Connect an IR emitter to PX-700 IR Out 1 or IR Out All and place the IR emitter over the IR receiver on the device.
- If the PX-700 has v2.0 or higher firmware and a Project is open, make sure the current Project's "All connected PX-700s have v1.10 or higher firmware?" and "Enable download of optimized IR codes" preferences are both selected so that Variable Length Optimized format codes can be tested. If a Project is not open, the last saved Project's Preferences will be in effect and a new Project might need to be created with these Preference settings. Variable Length Optimized codes cannot be tested with PX-700s equipped with v1.0 or v1.10 firmware.
- Test IR codes as they are learned, starting with the As Learned format.
 - Click the radio button next to 'As Learned' and click the Test button and observe the device being controlled for a response.
 - Repeat testing the code several times, each time waiting for the device's response.
 - If the code doesn't work, relearn the code and test it again. If the code still does not work, the Carrier Frequency might be set to the wrong value. You will need to use Variable Length Optimized format to change the carrier frequency. See Problems and Solutions for more information.
- If the code works in As Learned format, test the code in Variable Length Optimized Format.
- Click the radio button next to 'Variable Length Optimized' and click the Test button and observe the device being controlled for a response
- If the code does not work or works intermittently, the number of repeats might be set incorrectly or the code might be in a protocol that requires special treatment. See Problems and Solutions for more information.
-

2.5 Model Properties

The Model Properties dialog is used to define and edit the Properties associated with a Model.

- The Properties that can be defined are: the Name of the Model and the Model default settings for the Carrier Frequency and Number of Repeats that apply to IR codes stored in the Model.
- IR codes that are learned will automatically inherit the Model default settings.
- If IR codes are Pasted into the Model from another Model are compared to
- When Model Properties is opened, if there are *no* IR codes whose Properties are individually set to a Carrier Frequency and/or Number of Repeats value that is not 'use model defaults', the two options under 'Reset all IR codes to use...' will be grayed out and unavailable.
- If any IR codes in the Model *are* individually set to a set to a Carrier Frequency and/or Number of Repeats value that is not 'use model defaults', the appropriate option under 'Reset all IR codes to use...' will be available. To reset the Carrier Frequency and/or Number of Repeats for *all* IR codes in the Model to use the Model's default values, select the option and click 'Ok'. See Managing IR Codes for more information.

2.6 Managing IR Codes

3.0 Using IR Codes in Projects

4.0 IR Codes, Delays, and ATC Favorites and Library Macros

5.0 Tips and Techniques

- If you cannot download a Project into a PX-700 equipped with v1.1 firmware because the Project uses too many IR codes or exceeds the PX-700 memory limits:
 - Update the PX-700 firmware to v2.0.
 - Use Installation Manager v3.0.
 - Select "All connected PX-700s have v1.10 or higher firmware?" and "Enable download of optimized IR codes" in the Project Preferences so that Variable Length Optimized IR codes will be downloaded.
- If you are controlling a Denon product, set the Model Properties to Play/Repeat IR codes 'With no optimization'.
- If an IR code only works every other time when using 128 Byte Optimized or Variable Length Optimized format, do not use 128 Byte Optimized format, use As Learned or Variable Length Optimized format and set the Number of Repeats in Model Properties to 2 times.
- If an IR code is recognized, As Learned codes work properly, and 128 Byte Optimized or Variable Length Optimized formats do not control the source, examine the codes on the Summary Tab of the Manage IR dialog. If all the codes are the same regardless of which button on the remote they correspond to, do not use 128 Byte Optimized codes, use As Learned or Variable Length Optimized format and set the Model Properties to Play/Repeat IR codes 'With no optimization'.
- If codes do not control the source regardless of the IR code format, the Carrier Frequency is set to a value that does not match the device. Change the Carrier Frequency in the Model Properties dialog. Start at 57 kHz and try values about 5kHz apart (i.e. 57kHz, 52kHz, 47kHz, etc.) to determine the correct setting.
- Manufacturers whose IR codes should be recognized include: Adcom, Denon, General Instrument (some models), Harman Kardon, Hughes, Imerge, JVC, Madrigal, Marantz, Mark Levinson, Matsushita, Motorola, Nakamichi, Onkyo, Panasonic, Philips, Pioneer, Proceed, RCA, Rotel, Runco, Samsung, Scientific Atlanta (some models) Sony, Technics, Toshiba, and Yamaha.

6.0 Problems and Solutions

Problem: As Learned format codes control the device but 128 Byte Optimized and Variable Length Optimized format codes don't control the device.

Solution: Denon Products use an IR code protocol that requires two separate codes. The first code is the actual code and the second is a 'checksum' code. Installation Manager recognizes the Denon protocol but only retains the first code of the pair when As Learned codes are processed to 128 Byte Optimized and Variable Length Optimized formats. 128 Byte Optimized format will never work with Denon codes and therefore the "Enable download of optimized IR codes" Project Preference must be deselected before the Project is downloaded when the PX-700 has v1.0 or v1.10 firmware. If the PX-700 has v2.0 or higher firmware and the Project Preference "Enable download of optimized IR codes" is selected, Variable Length Optimized format can be made to work by following these steps:

- Close the Manage IR Codes Dialog.
- Open the Model Properties dialog by right clicking on the Model and selecting Model Properties from the pop up menu.
- Change the setting for Play/Repeat IR codes to 'With no optimization' (this entry is at the top of the list above '1 Time').
- Click Ok. The Model Properties dialog will close.
- Reopen the Manage IR Codes dialog and continue learning or testing IR codes.

Solution: The remotes for some of the products of some manufacturers (Pioneer is an example) transmit two different codes. One code controls the product and the other code controls another product from the same manufacturer. An example might be CD Play and AV Receiver Select CD Input. Installation Manager only keeps the first code it finds in 128 Byte Optimized and Variable Length Optimized formats. If this code doesn't control the Model, then these formats won't work.

- This case can be verified by opening Manage IR Codes, selecting the Summary tab, and examining the data and address for each code.
- If the data and address are the same, switch to the Graph tab and select the 'As Learned' view. Look at the pattern for the code. If there are and The solution is the same as for Denon codes, change the Model Properties for Play/Repeat IR codes to 'With no optimization'.

Solution: Some products require more than one repeat of the code for the code to work properly. We've seen products from Sony that require 2 repeats of the code and products from another manufacturer that need 3 or 4 repeats.

Installation Manager can trim too much of the code. Cable Boxes (GI) and Satellite (Dishnetwork)

Problem: 128 Byte Optimized or Variable Length Optimized formats only work every other time.

Solution: This is a case where the device needs two repeats of the code. There is no way to change the number of repeats with 128 Byte Optimized codes, but the number of repeats can be specified for Variable Length Optimized format codes.

- If the PX-700 has v1.0 or v1.10 firmware, deselect 'Enable download of optimized code' in the Project's Preferences and use As Learned codes instead.
- If the PX-700 has v2.0 or higher firmware and Variable Length Optimized codes are used, change the Model Properties for Play/Repeat IR codes to ' 2 times'.

Code doesn't work reliably in as learned format but does work reliably in Optimized formats.

PX-700 Page Pop!

PX-700

Page Pop is normal if:

1. Source level is set Low
2. Volume (master) is set Hi
- ~~3. Page Vol is set Hi~~
3. Page Vol. Level Does not Matter

Power Supply fuses:

F1: 500mA (Main) 380-00050-00

F2: 2.5A (switched outlet) 350207

Control Board fuse:

F1: 1.6A (KPS) 380-00160-00

(Same as PX-600 FRK KPS)

Power Supply:

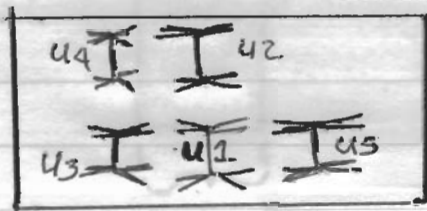

U1 = 5.0V_{dc} U5 = 5.0V_{dc}

U2 = 6.0V_{dc}

U3 = 5.0V_{dc} (-5V_{dc})

U4 = 5.5V_{dc} → -6.0V_{dc}

Power Supply PCB:



All 3 voltages are soft & very significantly.

Power Supply PCB:

F1: 500uA 250V
F2: 2.5A 250V

- J4: to P.B on/off sw.
- J5: to Hot sw. Outlet
- J8: to Neutral sw. Outlet
- J7: AC in Neutral
- J9: to ground lug

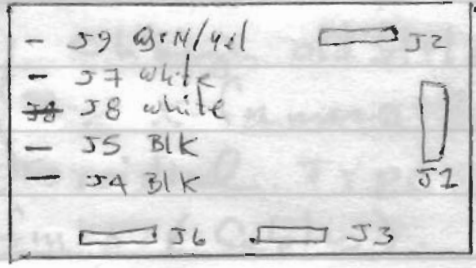

- J6: Transformer
- J3: Transformer

- J1: Audio PC Board
- J2: Control PC. Board

Power Supply PCB

- J2 BK → wh = 4.9Vdc
- BK → OR = 13Vdc +/- Unregulated
- BK → Rd = 5.08Vdc

PS Ground wire from L: Side Reduce to 4" length.

PX-700

New 485 for 700

270-00485-00

Sony (not verified)

CTRL PCB

802-00065-00

(No fuse or cap)

A/V RECORDER :

STRDE 935

won't program on
PX-700

Control PCB

F2

KPS fuse

1.6 A (SB)

380-00160-00

F2
Service Outlet

2.5 A (SB)

350207

F1

Main fuse

500 mA (SB)

380-00050-00

↑
SPEAKER
Power Supply PCB
↓
Parts Overhaul

PX700 PARTS LIST	
380-00250-00	FUSE 2.5A 250V SLO-BLO 5X20 MM (outlet)
380-00160-00	FUSE 1.6A 250V SLO-BLO 5X20 MM (kps)
380-00050-00	FUSE 500MA 250V SLO-BLO 5X20 MM (pwr s.b)
270-00485-00	IC DIG LTC485CN8 RS485 DIFF RCVR
250-10552-00	ICS DIG 80C552 MICROP 16MHz PLCC68
260-03012-00	ICS MEM SRAM DS1230Y-120 NON VOLATILE
900-00065-00	PROG EPROM PX-700 V 1.0
900-00065-01	PROG EPROM PX-700 V 1.1
802-00065-00	CONTROL BOARD ASSEMBLY
380-000160-00	include fuse w/ board + fuse holder included
260-03012-00	SRAM