



LIPPERT COMPONENTS

***ELECTRIC SLIDEOUT SYSTEM
OPERATION AND SERVICE MANUAL***

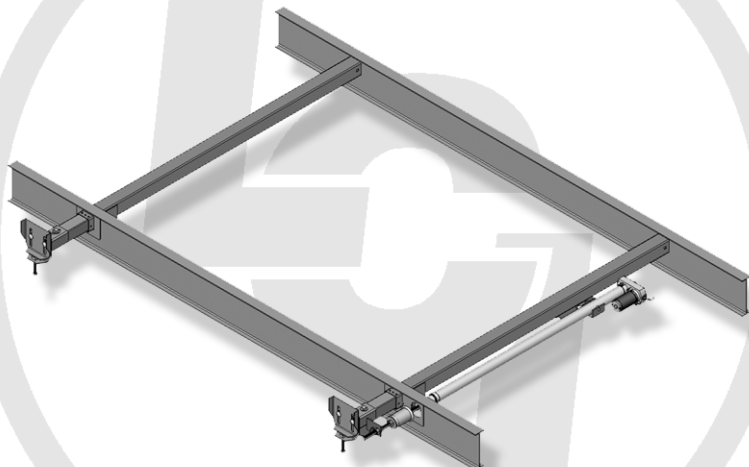



TABLE OF CONTENTS

SYSTEM.....	3
Warning.....	3
Description.....	3
Prior to Operation.....	4
Preventative Maintenance.....	4
OPERATION.....	5
Warning.....	5
Extending Slideout Room.....	5
Retracting Slideout Room.....	5
Manual Operation.....	6
SERVICE.....	9
Adjustment Instructions.....	9
System Components.....	12
Synchronizing System.....	14
Replacing Actuator.....	15
Troubleshooting.....	16
Wiring Diagram.....	19
Ordering Parts.....	20
LIMITED WARRANTY.....	21
Warranty Registration.....	23

SYSTEM

WARNING

FAILURE TO ACT IN ACCORDANCE WITH THE FOLLOWING MAY RESULT IN SERIOUS PERSONAL INJURY OR DEATH.

The *Lippert Electric Slideout System* is intended for the sole purpose of extending and retracting the slideout room. Its function should not be used for any other purpose or reason than to actuate the slideout room. To use the system for any reason other than what it is designed for may result in damage to the coach and/or cause serious injury or even death.

Before actuating the system, please keep these things in mind:

- 1. Parking locations should be clear of obstructions that may cause damage when the slideout room is actuated.**
- 2. Be sure all persons are clear of the coach prior to the slideout room actuation.**
- 3. Keep hands and other body parts away from slideout mechanisms during actuation. Severe injury or death may result.**
- 4. To optimize slideout actuation, park coach on solid and level ground.**

Description

The Lippert Electric Slideout System is a rack & pinion guide system, utilizing an electric ball screw actuator to move the room assembly. The motor drives the ball screw in a forward and backward motion to drive the slide room in and out. The actuator comes equipped with an automatic clutching system. *The Lippert Electric Slideout System* is designed to operate as a negative ground system.

PRIOR TO OPERATION

Prior to operating the *Lippert Electric Slideout System*, follow these guidelines:

1. Coach should be parked on the most level surface available.
2. Leveling or stabilizing system should be actuated to ensure coach will not move during operation of Slideout System.
3. Be sure battery is fully charged.
4. Be sure to keep all persons and pets clear of Slideout System during operation.

SYSTEM MAINTENANCE

The *Lippert Electric Slideout System* has been static tested to over 4,000 continuous cycles with out any noticeable wear to rotating or sliding parts. It is recommended that when operating in harsh environments (road salt, ice build up, etc.) the moving parts be kept clean and can be washed with mild soap and water. No grease or lubrication is necessary and in some situations may be detrimental to the environment and long term dependability of the system.

Electrical System Maintenance

For optimum performance, the slide-out system requires full battery current and voltage. The battery must be maintained at full capacity. Other than good battery maintenance, check the terminals and other connections at the battery, the control switch, and the electric actuator motor for corrosion, and loose or damaged terminals. Check motor leads under the trailer chassis. Since these connections are subject to damage from road debris, be sure they are in good condition.

Note: The *Lippert Electric Slideout System* is designed to operate as a negative ground system. A negative ground system utilizes the chassis frame as a ground and an independent ground wire back to battery is necessary (see page 19 for wiring diagram). It is important that the electrical components have good wire to chassis contact. To ensure the best possible ground, a star washer should be used. Over 90% of unit electrical problems are due to bad ground connections.

Mechanical Maintenance

Although the system is designed to be almost maintenance free, actuate the room once or twice a month to keep the seals and internal moving parts lubricated.

Check for any visible signs of external damage after and before movement of the travel trailer.

NOTE: *For long-term storage: It is recommend that the room be closed (retracted).*

OPERATION

WARNING

FAILURE TO ACT IN ACCORDANCE WITH THE FOLLOWING MAY RESULT IN SERIOUS PERSONAL INJURY OR DEATH.

ALWAYS MAKE SURE THAT THE SLIDEOUT ROOM PATH IS CLEAR OF PEOPLE AND OBJECTS BEFORE AND DURING OPERATION OF THE SLIDEOUT ROOM.

ALWAYS KEEP AWAY FROM THE SLIDE RAILS WHEN THE ROOM IS BEING OPERATED. THE GEAR ASSEMBLY MAY PINCH OR CATCH ON LOOSE CLOTHING CAUSING PERSONAL INJURY.

INSTALL TRANSIT BARS (IF SO EQUIPPED) ON THE SLIDEOUT ROOM DURING STORAGE AND TRANSPORTATION.

EXTENDING SLIDEOUT ROOM

1. Level the unit.
2. Verify the battery is fully charged and hooked-up to the electrical system.
3. Remove the transit bars (if so equipped).
4. Press and hold the IN/OUT switch (Fig. 1B) in the OUT position until the room is fully extended and stops moving.
5. Release the switch, which will lock the room into position.

Note: If the slideout switch is held after the room is fully extended, the control will sense that the room has stopped and will shut off the motor after a few seconds.

RETRACTING SLIDEOUT ROOM

1. Verify the battery is fully charged and hooked-up to the electrical system.
2. Press and hold the IN/OUT switch (Fig. 1C) in the IN position until the room is fully retracted and stops moving.
3. Release the switch, which will lock the room into position.

NOTE: If the slideout switch is held after the room is fully retracted, the control will sense that the room has stopped and will shut off the motor after a few seconds.

4. Install the transit bars (if so equipped).

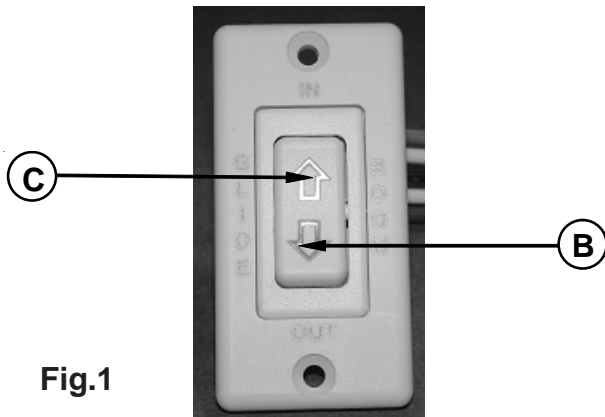

Fig.1

MANUAL OPERATION

WARNING!

Always disconnect battery from system prior to manually operating system. Failure to disconnect battery can cause electricity to backfeed through the motor and cause serious damage to the system as well as void the warranty.

The Lippert Electric slide comes with a manual over ride system. Locate the crank extension with pin outside of the chassis main rail as, Fig. 2, page 7, shows underneath the unit on the end of the motor (If your crank extension is under the inside of the frame, please refer to page 8). This is where the crank handle (standard fifth wheel landing gear crank handle or 3/4" socket and ratchet fits on to allow the manual extension/retraction of the room, Fig. 4-5, page 8. Simply take the crank handle (through-frame models) or wrench, ratchet or drill with a nut driver (in-frame models) and rotate it clockwise to retract and counterclockwise to extend slide-out. It is important to note that you DO NOT need to attempt to disengage the motor as the actuator is "manual ready" Just hook up and crank.

Use EXTREME CAUTION when extending and/or retracting room using the manual override feature. It is possible to operate the slideout beyond the maximum extension and/or retraction and damage the slide components, slide room structure or trim components.

WARNING!

The gears can be stripped out if the room is manually retracted/extended to it's fullest extent and the operator continues to rotate manual override. Any damage due to misuse of the Manual Override feature will disqualify any and all claims to the Limited Warranty.

MANUAL OPERATION - THROUGH FRAME

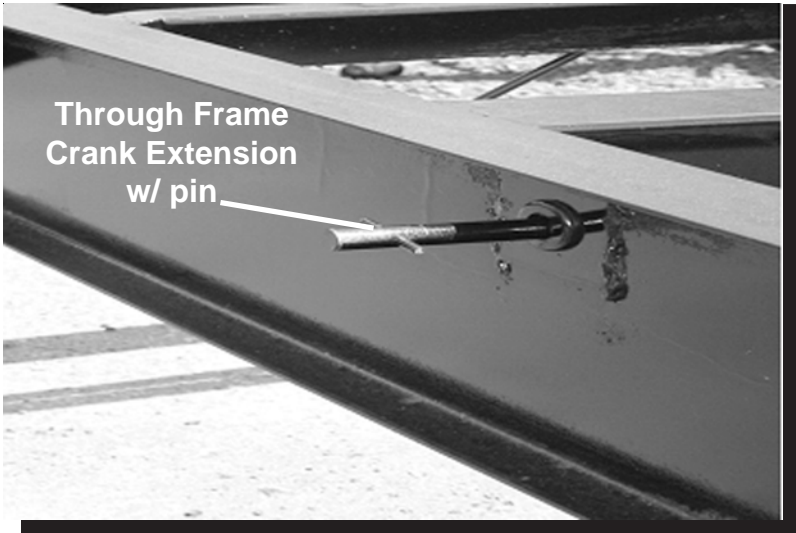

Fig. 2

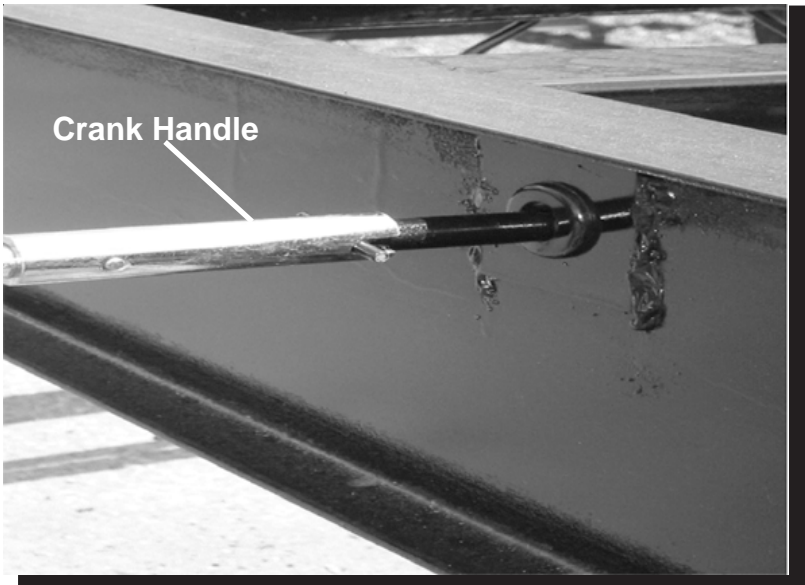

Fig. 3

MANUAL OPERATION - IN FRAME

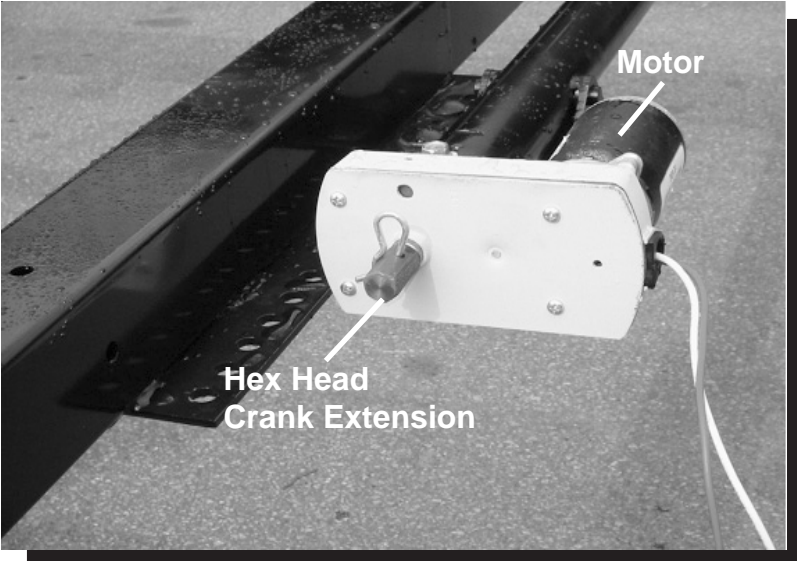

Fig.4

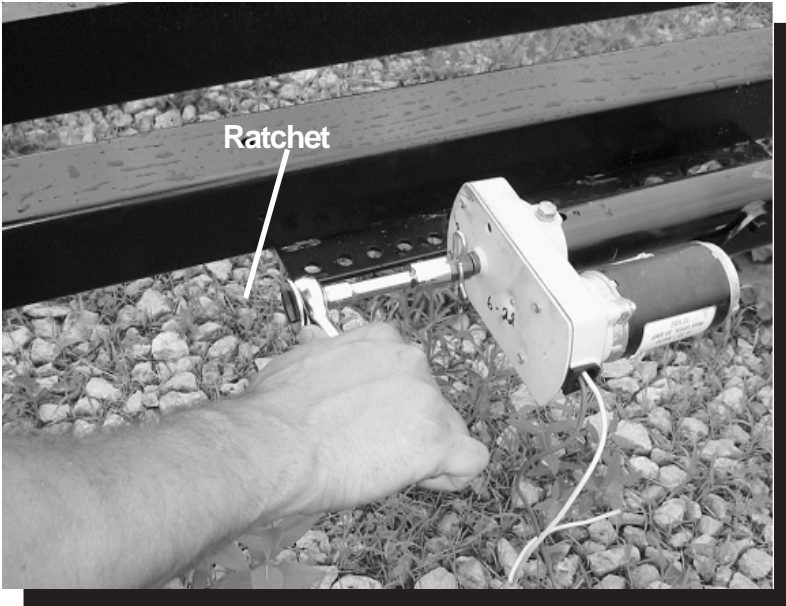

Fig.5

SERVICE

MECHANICAL ROOM ADJUSTMENT

Vertical & Horizontal Room Adjustment

NOTE: All slideout room adjustments must be performed by certified service technicians. Adjustments made by non-certified persons may void any and all warranty claims.

Horizontal adjustment

1. Loosen 2 carriage bolts "A" on each bracket located at the end of each guide tube.
2. Room is ready to be positioned horizontally by pushing on the outside, sidewall or by using a prying devise inserted into the opening between the room and coach.

Note: Use caution when using prying devise so seals do not become damaged.

Vertical adjustment

1. Loosen 2 carriage bolts "A" on each bracket located at the end of each guide tube
2. Loosen jam nut
3. For vertical adjustment turn vertical adjustment bolt "B" up or down to locate room height.

Once room is located, tighten "A" and Jam Nut bolts.

MECHANICAL ROOM ADJUSTMENT

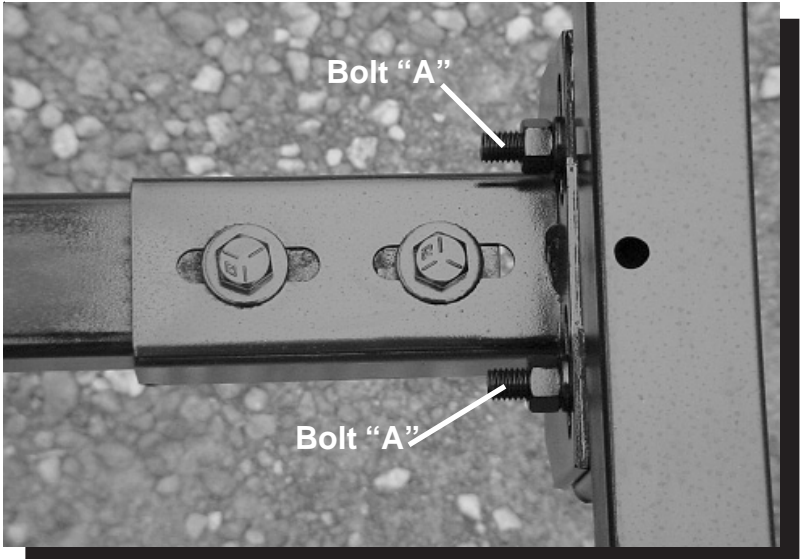

Fig.6

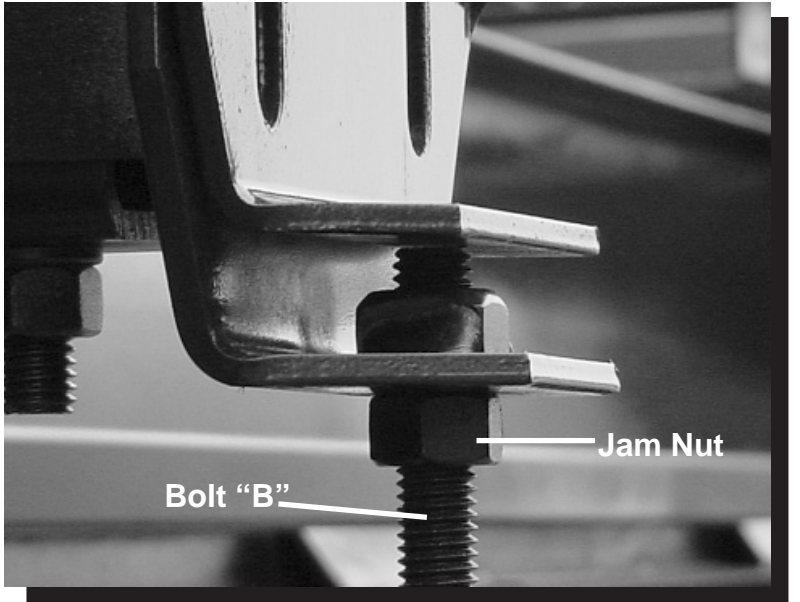
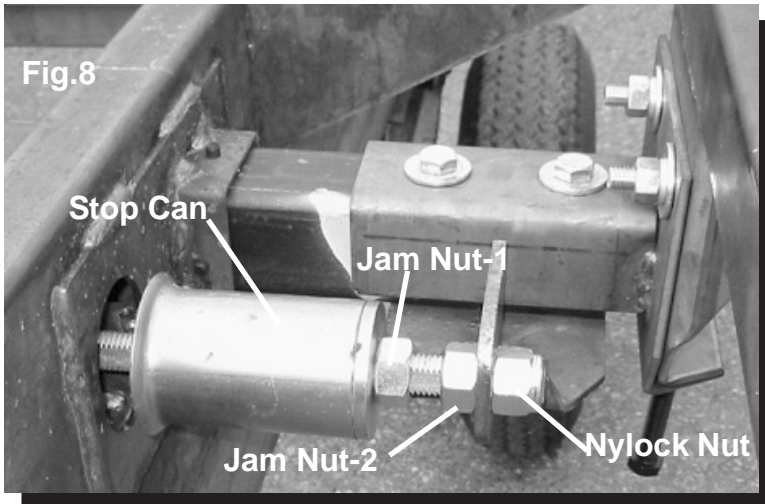

Fig.7

MECHANICAL ROOM ADJUSTMENT-CONT.



Adjusting room so it seals in the IN position

1. Locate actuator coming through the frame
2. On the end of the actuator there is a threaded shaft mounted to the drive bracket with 3 nuts and a stop can.
3. Loosen the $\frac{3}{4}$ " nut (Jam Nut-1) on the outside of the stop can.
4. Screw the can out or in, and then tighten down the nut – this will change the location of your seal going to the "in position".

Adjusting room so it seals in the OUT position

1. Locate actuator coming through the frame.
2. On the end of the actuator there is a threaded shaft mounted to the bracket with 3 nuts and a stop can.
3. Move one of the 1" nuts (Jam Nut-2 or Nylock Nut) one way or the other– this will change the location of your seal going to the "out position".
4. Make sure all nuts are tight.

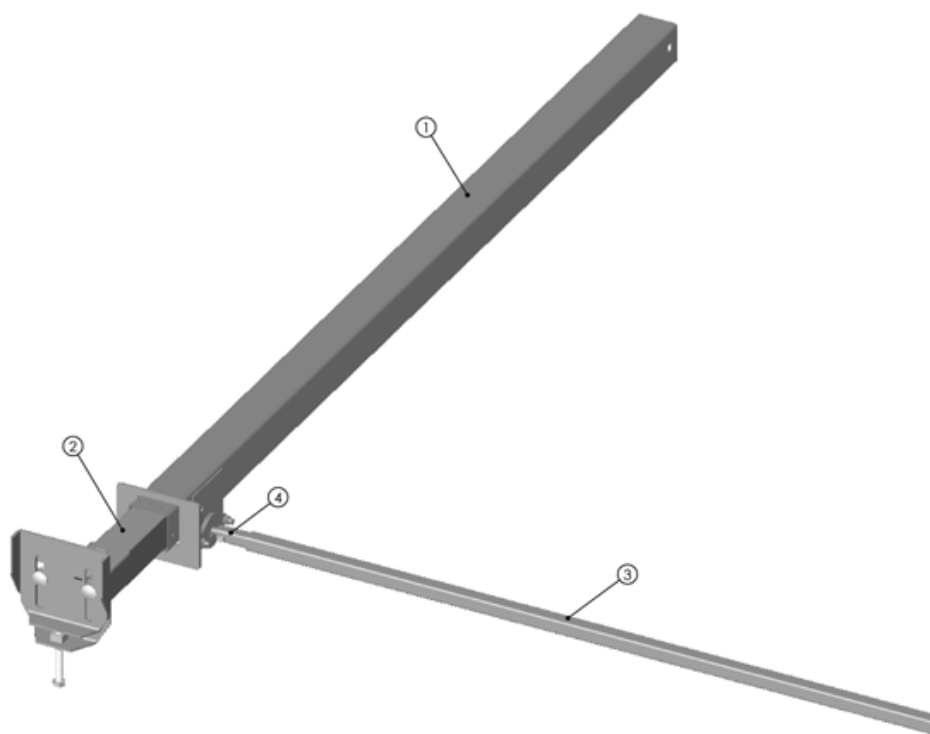

ITEM NO.	PART NUMBER	QTY
1	OUTER RAIL ASSEMBLY	2
2	INNER RAIL ASSEMBLY	2
3	OUTER DRIVE TUBE	1
4	INNER DRIVE TUBE	1
5	ACTUATOR	1
6	MOTOR ASSEMBLY	1
7	ADJUSTMENT ASSEMBLY	1

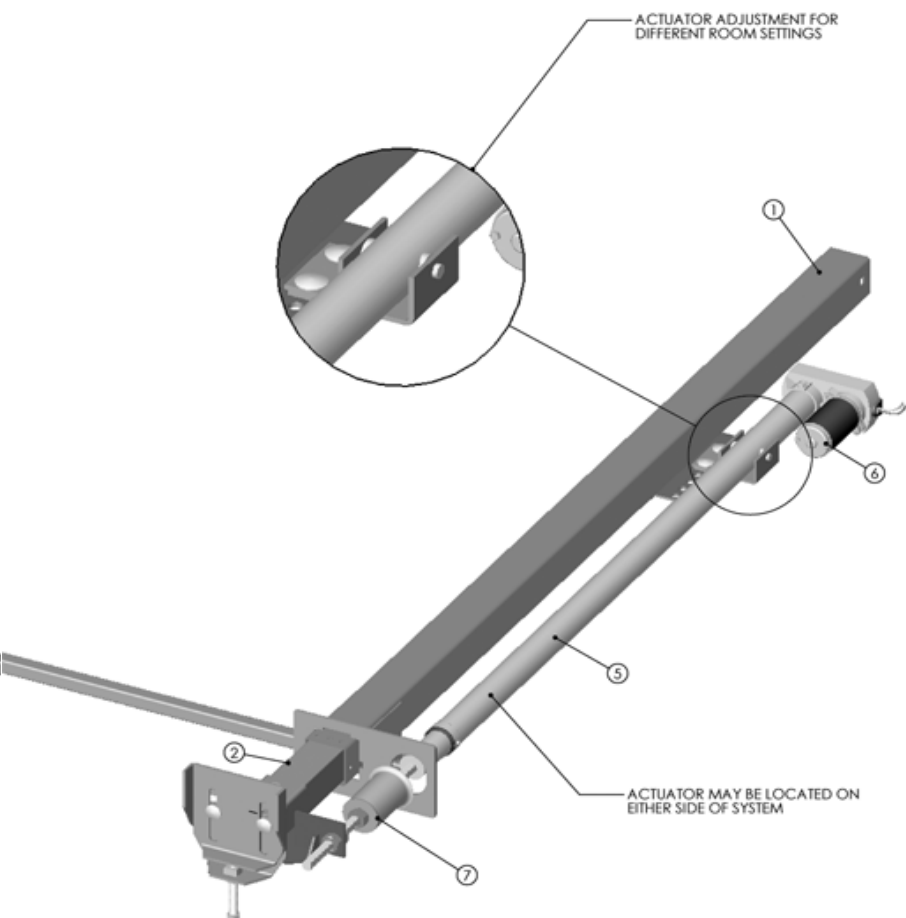

LIPPERT ELECTRIC SLIDEOUT SYSTEM



LIPPERT COMPONENTS

SYNCHRONIZING ROOM TRAVEL

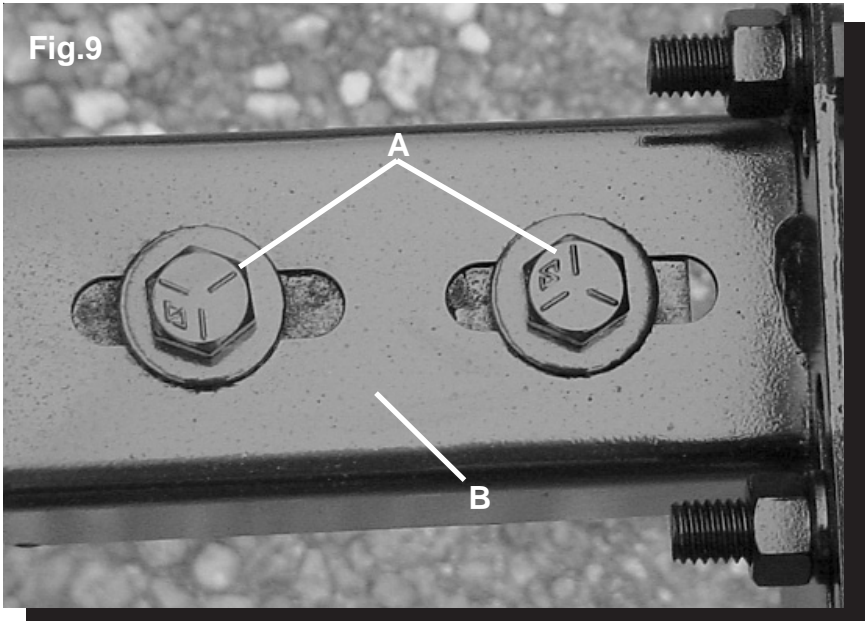

The *Lippert Electric Slideout System* room travel (both sides of the room traveling the same distance) can be adjusted with specially designed synchronizing bracket mounted on the passive slide tube. The passive slide tube is the one that is not powered. The active slide tube is the one that has the cylinder attached. If one side of the room fails to seal adjust as follows:

1. Loosen bolts (Fig. 9 A) on top of the passive slide tube (Fig. 9B)
2. Push or pull room (on the passive side) to align with the active side.

REMOVING AND REPLACING ACTUATOR

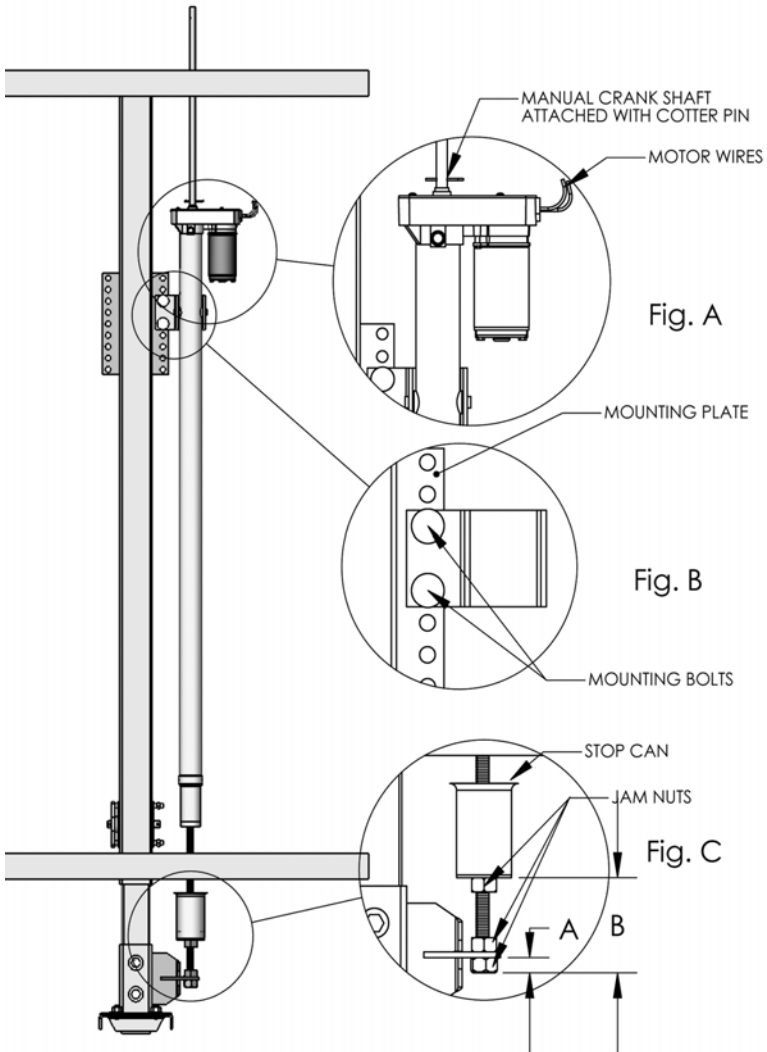

To replace actuator:

1. Disconnect manual crank shaft from end of motor assembly (Fig. A).
2. Disconnect motor wires from source. (Fig. A).
3. Take measurements A and B (Fig. B).
4. Remove all jam nuts (3 total) and stop can from threaded shaft on actuator (Fig. B)
5. Take note of mounting bolt locations and remove mounting bolts (Fig. C).
6. After everything is disconnected, slide actuator out of frame. To replace with new actuator, follow previous directions in reverse.

TROUBLESHOOTING

The *Lippert Electric Slideout System* is only one of four interrelated slideout room system components. These four components are: chassis, room, coach, and *Lippert Electric Slideout System*. Each one needs to function correctly with the others or misalignment problems will occur.

Every travel trailer has its own personality and what may work to fix one trailer may not work on another even if the symptoms appear to be the same.

When something restricts room travel, system performance will be unpredictable. It is very important that slide tubes be free of contamination and allowed to travel full distance (Stroke). Ice or mud buildup during travel is an example of some types of contamination that can occur.

When you begin to troubleshoot the system, make sure the battery is fully charged, there are no visible signs of external damage to the actuator or motor and that the motor is wired correctly and all connections are secure.

You can adjust the room extension with the jam nuts on the end of the actuator threaded rod (see page 11).

During troubleshooting, remember that if you change something, that change may affect something else. Be sure any changes you make will not create a new problem.

**You can obtain additional information on the
Lippert Electric Slideout System
by calling 866-524-7821.**

System Troubleshooting Chart

The following troubleshooting chart outlines some common problems, their causes and possible corrective actions. When reference is made to "Power Unit" it is referring to the motor and actuator as a complete assembly. All Power Units are shipped from the factory with a serial number and date code, which should be given to the service technician when asking for assistance.

ROOM DOESN'T MOVE WHEN SWITCH IS PRESSED

<u>Probable cause</u>	<u>Corrective action</u>
Restrictions both inside and out side unit.	Check for and clear restriction.
Low battery voltage, blown fuse, defective wiring.	Check battery. Charge battery or add auxiliary power source. Check battery terminals, and all other wiring. Look for loose/corroded connectors.
Power unit not functioning.	See "Troubleshooting" on page 5.

POWER UNIT RUNS, BUT ROOM DOES NOT MOVE

Actuator not attached to front mounting drive bracket.	Check jam nuts/nylock nuts. Be sure that they are properly tightened and adjusted.
Bad motor or gear housing.	Replace motor.

POWERUNIT RUNS, BUT ROOM MOVES SLOWLY

Low battery, poor ground, extremely low outdoor temperature.	Charge battery, and check ground wire.
Room is in a bind.	Check to see that room is properly adjusted

ROOM STALLS IN MID TRAVEL

Actuator in a bind.	Crank manual override and move room short distance then retry electric switch to move room.
Bad actuator.	Replace actuator if above instructions do not work.

NOTES:

- If the slideout room will not retract there is a manual override that is located on the opposite side of the slideout room. A crank handle is provided with your unit. Once you have the room in the closed position take you unit to the closest dealer. See pages 8 & 9.
- Switch related problems
 - o If room moves opposite from what the switch plate indicates, reverse the motor wires on back of switch (refer to the wiring diagram). Wire size must be 10 GA. Minimum.
 - o If you find that you have a stripped gear, replace the gear pack.
 - o If the room is out of time / synchronization, refer to pages 10 & 13.

TROUBLESHOOTING – MOTOR

Before attempting to troubleshoot the Motor, make sure an adequate power source is available. The unit batteries should be fully charged or the unit should be plugged into to A/C service with batteries installed. Do not attempt to troubleshoot the Motor without assuring a full 12V DC charge

The following tests require only a DC voltmeter (or DC test light) and a jumper lead.

Step 1 - Attach voltmeter (or test light) leads to the negative and positive switch terminals on back of wall switch (See Fig. 10). Does the meter indicate 12V DC?

If **YES**, see **Step 2**; if **NO** see **Step 3**.

Step 2 - If **YES**, at the motor, check the incoming leads to 12V DC (if necessary, disconnect leads at wire splices). Does meter indicate 12V DC? If **YES**, Motor needs to be replaced. The motor is not field serviceable. **DO NOT ATTEMPT TO REPAIR**. If **NO**, Inspect all wires and connections between the wall switch and the motor. Repair connections as necessary. Recheck as in **Step 1**.

Step 3 - If **NO**, Inspect all connections between battery and switch. Inspect 30A Auto-reset Circuit Breaker (See Fig. 10 for location). Recheck as above in **Step 1**.

Since there are no field serviceable parts in the motor, electrical troubleshooting and service is limited to replacing only those components as previously outlined.

Thorough inspection of wiring and connections is the only other electrical service that can be performed.

WIRING DIAGRAM

Fig. 10

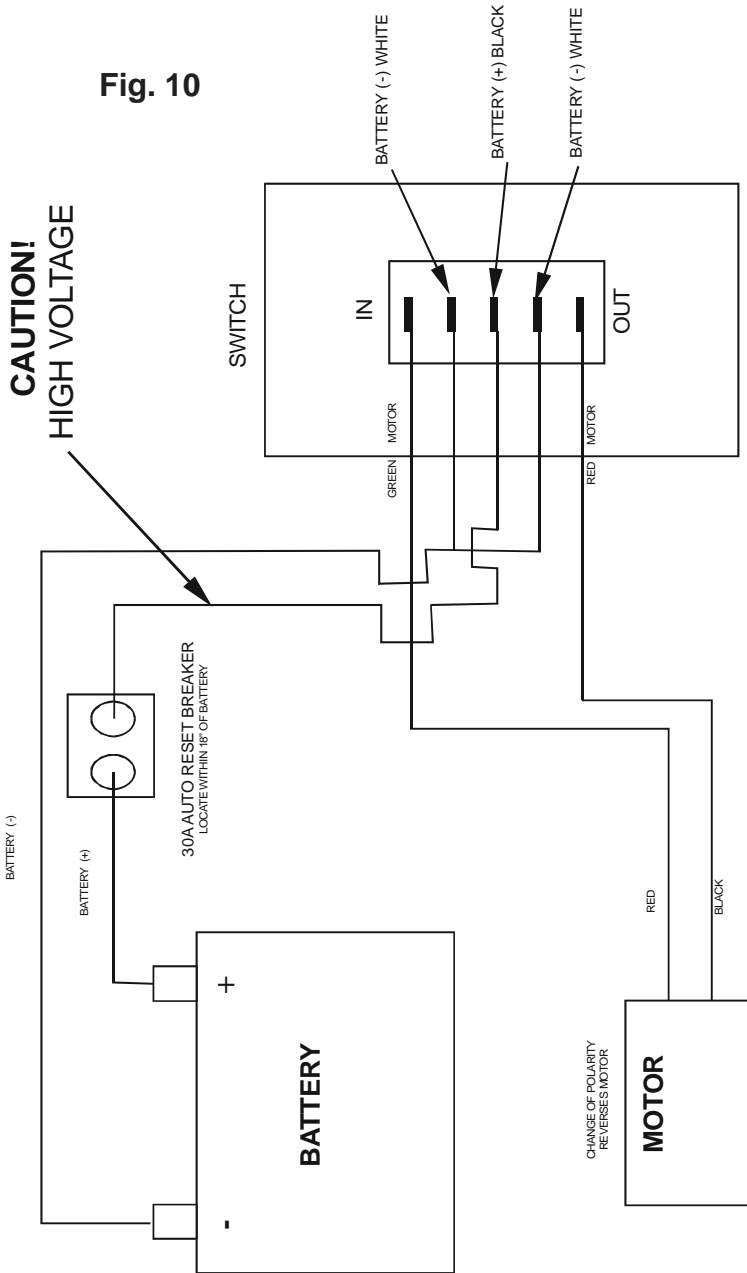

ORDERING PARTS

To assist the customer service when ordering parts, please provide the following information:

1. Your Name
2. Company Name
3. Phone Number
4. Shipping Address
5. Billing Address
6. Purchase Order Number
7. Coach
 - A. Serial # and/or VIN #
 - B. Make
 - C. Model
8. Part Number
9. Description
10. Quantity

Please take your coach to an authorized service center for repairs. Systems that have been modified, adjusted, repaired or augmented by a party other than an authorized service center may void any warranty claim with Lippert Components, Inc.

LIMITED WARRANTY

THIS WARRANTY EXTENDS ONLY TO THE MERCHANT/ORIGINAL PURCHASER ("Purchaser") ACQUIRING THE PRODUCT, AS DEFINED HEREIN, DIRECTLY FROM A LIPPERT COMPONENTS FACILITY AND SHALL NOT BE CONSTRUED TO EXTEND TO ANY THIRD PARTY, INCLUDING BUT NOT LIMITED TO THE CONSUMER OR ULTIMATE PURCHASER OF THE END PRODUCT. IN PART, THE PURPOSE OF THIS PROVISION IS TO REQUIRE THAT ANY AND ALL WARRANTY CLAIMS BE MADE BY THE MERCHANT/ORIGINAL PURCHASER, AND NOT BY A CONSUMER. THIS WARRANTY SUPERCEDES ANY AND ALL PRIOR WARRANTIES.

LIPPERT COMPONENTS warrants the components of it's Recreational Vehicle Slide-Out System ("Product") against defects in materials and workmanship for the following time periods, beginning on the date of Retail Sale, so long as the Retail Sale occurs within six (6) months of the date Purchaser acquires the Product directly from a Lippert Components facility:

Three (3) Years – Any ball screw actuator, inner and out tube assembly, rack and gear assembly, electric motor and cross shaft.

Five (5) Years – Any fluid power components, limited to any hydraulic cylinder and hydraulic pump.

If a LIPPERT COMPONENTS Product is inspected by an authorized LIPPERT COMPONENTS representative and is determined to be defective in materials or workmanship within the aforementioned time period and pursuant to the requirements set forth herein, LIPPERT COMPONENTS will, in its sole and absolute discretion, do one of the following:

Repair or replace without charge FOB it's factory;

Send a service team to the then current location of the Product to repair or replace it on site; or allow credit for the Product.

All warranty claims MUST involve an inspection of the Product and be approved by an authorized LIPPERT COMPONENTS representative, and all repair procedures must be pre-approved by LIPPERT COMPONENTS before any repair work can begin. There are no exceptions to this procedure, so please contact your LIPPERT COMPONENTS division immediately before attempting any repairs or modifications on your LIPPERT COMPONENTS Product. No claim for Products alleged to be defective will be allowed until LCI has had a reasonable opportunity to investigate each claim.

This warranty does not cover customer instruction, installation or set up adjustments. Unless otherwise indicated by tangible evidence, LIPPERT COMPONENTS relies upon the engineering professionals of those that purchase its Products to design and specify a Product of sufficient size, dimension, strength and durability to support the structure the Purchaser intends to place upon the Product, and to design and specify a Product that is sufficient and adequate to function in the role the Purchaser intends to use and/or produced by its Purchasers and builds Products pursuant to those design specifications.

This warranty does not cover abuse, misuse or neglect, but is not limited to, improper usage, overloading, accident related damage, improper loading or incorrect weight bias loading, damage resulting from improper operation or maintenance, connection to improper towing unit or attempted repair by anyone other than an authorized representative of LIPPERT COMPONENTS. This warranty does not cover cosmetic damage, damage due to acts of God, commercial use or modification of the Product, or Products sold AS IS and/or WITH ALL FAULTS. This warranty is valid only in the United States and Canada.

EXCEPT TO THE EXTENT PROHIBITED BY APPLICABLE LAW, ANY IMPLIED WARRANTIES OF MERCHANTABILITY OR FITNESS FOR A PARTICULAR PURPOSE ARE HEREBY DISCLAIMED. REPAIR, REPLACEMENT OR CREDIT AS PROVIDED UNDER THIS WARRANTY IS THE EXCLUSIVE REMEDY OF THE PURCHASER. IN NO EVENT WILL LIPPERT COMPONENTS BE LIABLE FOR INCIDENTAL OR CONSEQUENTIAL DAMAGES.

Claims – All claims are barred unless reported in writing by Purchaser to LIPPERT COMPONENTS, with full particulars, promptly after the damage was or reasonably should have been discovered and full facilities are offered LIPPERT COMPONENTS for inspection and investigation. LIPPERT COMPONENTS will not consider any claims for material that is not in the original form.

All written notices required by this warranty shall be sent to:

Lippert Components, Inc.
Attn: Risk Management Department
2375 Tamiani Trail N., Suite 1101
Naples, FL 34103

This warranty is invalid if factory applied identification criteria have been altered or removed from the Product.

Work performed by others must have the prior authorization of LIPPERT COMPONENTS to be honored.

Third-Party Events – In the event of any accident, injury to person, damage to property, loss or other occurrence involving a LIPPERT COMPONENTS Product, Purchaser shall notify LIPPERT COMPONENTS of such event within thirty (30) days of the event or within ten (10) days of the notification to Purchaser, whichever is earlier. Notwithstanding the foregoing, Purchaser shall notify LIPPERT COMPONENTS **immediately** upon learning that a survey, test or inspection is to be made with respect to the LIPPERT COMPONENTS Product and provide LIPPERT COMPONENTS with the opportunity to participate in any such survey, test or inspection, or to permit LIPPERT COMPONENTS to conduct its own survey, test or inspection. Failure to comply with each of the foregoing shall bar any claim by the Purchaser against LIPPERT COMPONENTS concerning any such event and shall require Purchaser to defend, indemnify and hold LIPPERT COMPONENTS harmless from all claims asserted against LIPPERT COMPONENTS concerning any liability of LIPPERT COMPONENTS arising out of such event.

Severability – Any legally or otherwise invalid provision hereof shall be considered severable.

Any conditions or exceptions which may be stated in any communication or document received by LIPPERT COMPONENTS from any entity or individual, including but not limited to the Purchaser, shall be of no effect unless specifically agreed to in writing by LIPPERT COMPONENTS.

The current warranties and terms outlined on LIPPERT COMPONENTS' website (www.lippertcomponents.com) on the date of the purchase shall take precedence over any other warranties whether verbal or written. LIPPERT COMPONENTS reserves the right to alter its warranties from time to time, as the laws and the company's business needs and industry change.

TO THE GREATEST EXTENT PERMITTED BY LAW, ANY CONTROVERSY OR CLAIM ARISING OUT OF OR IN RELATIONS TO THIS WARRANTY SHALL BE DETERMINED BY BINDING ARBITRATION IN NAPLES, FLORIDA (COLLIER COUNTY) IN ACCORDANCE WITH THE COMMERCIAL ARBITRATION RULES OF THE AMERICAN ARBITRATION ASSOCIATION. PURCHASE OF THE PRODUCT CONSTITUTES PURCHASER'S AGREEMENT TO THIS PROVISION.

Lippert Components, Inc.
Warranty Registration Card

Attention Purchaser: Please fill out form as completely as possible, detach at the dashed line above and mail this card to Lippert Components, Inc. at the following address within 30 days of the retail purchase date of your unit to activate the warranty of this product.

Lippert Components, Inc. - Plant #39
Attn: Service and Warranty

2703 College Ave.
Goshen, IN 46528

Call us toll free at: (866) 524-7821

Find us on the web: <http://www.lci1.com/warranty.html>

RV Description _____ (Manufacturer) _____ (Model) _____ (Year)

_____ (VIN Number) _____ (Number of Slideouts)

Date of Unit Manufacture ____/____/____ Date of Unit Purchase ____/____/____

Check ALL that apply: Lippert Electric Slideouts Lippert Hydraulic Slideouts Lippert Leveling Other Lippert Products

Owner Name _____

Address _____ (Apt No. or Lot No.) _____

_____ (City) _____ (State) _____ (ZIP Code)

Phone Numbers: Cell(____)____-____ Home(____)____-____

