

FOGMAKER

User manual

Fire extinguisher system for engine compartments

Edition 2011-1

- Hydro pneumatic activation
- Mechanical activation
- Electrical activation



Marine applications

Fogmaker International AB

Postal address:
Box 8005
350 08 Växjö

Delivery address:
Sandvägen 4
352 45 Växjö

Tel: +46 470-77 22 00
Fax: +46 470-77 22 10
info@fogmaker.com
www.fogmaker.com

Part no. 8016-002

1. General description

This vehicle or machine is equipped with a fire extinguisher system for the engine compartment and possible separate heating areas. Depending on which version that is installed the extinguishing is activated hydro pneumatically, mechanically or electrically. In certain cases the extinguisher system can have both mechanical and electrical activation.

When extinguishing the extinguishant is sprayed through nozzles that break down the fluid into pillar-shaped mist clouds that cool the temperature and force the air out. The extinguishant is mainly based on antifreeze water. The extinguishing time is normally between 3-5 seconds and the effective time is 50-75 seconds.

2. Pertaining components

The components in the extinguisher system that are common, irrespective of the type of activation, are extinguisher cylinder (1) located in a separate area, hydraulic hose (2), pipe system with nozzles (3) located above the engine (4).

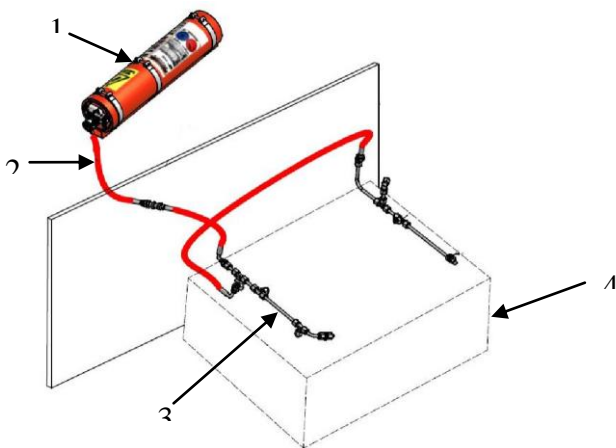

For systems with hydro pneumatic activation or electric activation there are often in the driver's position alarm lamps and alarm sirens that give signals in the event of a fire or as an option, warn for low pressure in the extinguisher cylinder or the detector cylinder or in the event of smoke emission. There may also be an alarm panel with optical or acoustical signals or with voice messages. The alarm panel can also have functions such as automatic engine shut-off, releaser delay, fuel and main power shut-off.

Alarm lamps, sirens and test buttons can also be integrated into existing systems in the vehicle, e.g., CAN bus – multiplexer, see the vehicle manufacturer's manual.

2.1 Hydro pneumatic activation

Hydro pneumatic activation takes place semi or fully automatically without any power supply.

The activation takes place with the help of a pressurized fluid-filled detector hose containing polymer (1) mounted in the upper part of the engine compartment and connected between a detector cylinder (2) and the extinguisher cylinder (3). The detector cylinder is normally located in the same compartment as the extinguisher cylinder. (not in the engine compartment!)

Fogmaker alarm lamp and alarm buzzer in the event of fire or low pressure in the detection system (5), Fogmaker alarm lamp and alarm buzzer for low pressure in the extinguisher cylinder (optional) (5), optical smoke alarm (optional) (6), vehicle alarm panel e.g., CAN bus – multiplexer (7).

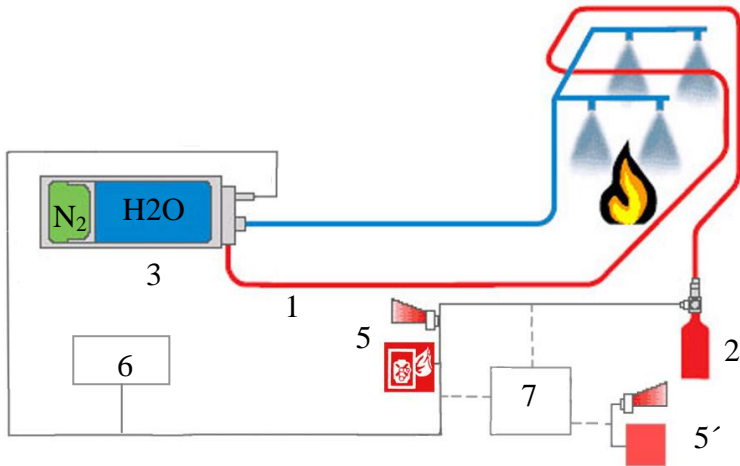

In the event of fire the detector hose bursts. When the pressure drop in the detection system has fallen to approx 10 bar a valve on the extinguisher cylinder is activated and the system is released. The pressure switch on the detector cylinder sends an alarm to the driver position.

With a semiautomatic system, depending on the version that has been installed, either the vehicle contact key shall be turned off or the handbrake pulled on or the ladder lowered in order that the extinguishing shall be activated in the event of a fire. The activation is delayed until this point with the help of a magnetic valve connected to the detector hose and this maintains the detector pressure to the extinguisher cylinder.

(Note the vehicle manufacturer's appendix for information about the activation that is used)

On delivery of the system the detector cylinder shows approx 20-24 bar, and is filled with detector fluid and a propellant. The propellant consists of nitrogen gas. The pressure can be read off on a manometer and shall be within the green sector. If the pressure falls below 14bar which means too low a system pressure the pressure

switch sends an alarm, *the same alarm as with a fire*. As an option there is a detector cylinder with an extra pressure switch that sends an alarm if the pressure falls below 7 bar which means that the system is released with a fire. The detector cylinder has a tap that shall be open when the system is active.

The working temperature for the cylinder should be between -30 / +65 °C.

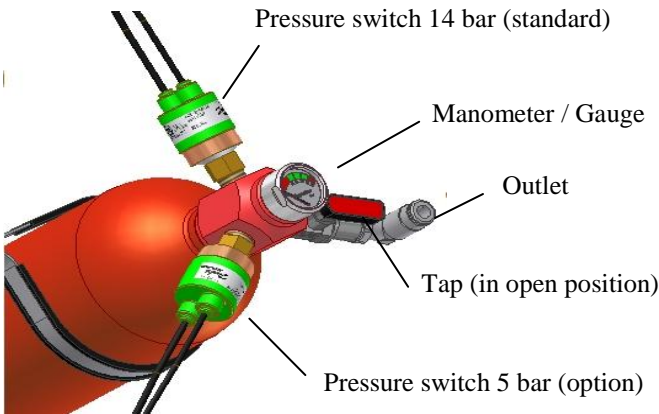

All pressure switches is type NO, which means that they will open when the pressure drops.

As an option there is also a manual and electric punch that is mounted on the detector hose. With the help of this the driver can manually trigger the system by cutting off the detector hose.

2.2 Mechanical activation

An extinguisher system with mechanical activation is released manually with the help of one or more pull-handles that are connected to the extinguisher cylinder valve with wires. The pull-handles are normally located in the driver position and on the outside of the vehicle. The handles are equipped with shackle locks that can be sealed. The handles are marked with labels (E).



2.3 Electric activation

The extinguisher system with electric activation is triggered either manually from a push button normally located in the driver position, semi automatically or fully automatically with the help of a detector cable or smoke sensors connected to an alarm panel. With a semiautomatic system, depending on the version that has been installed, either the vehicle contact key shall be turned off or the handbrake pulled on or the ladder lowered in order that the extinguishing shall be activated in the event of a fire. The activation is delayed until this point with the help of a magnetic valve connected to the detector hose and this maintains the detector pressure to the extinguisher cylinder. (Note the vehicle manufacturer's appendix for information about the activation that is used).

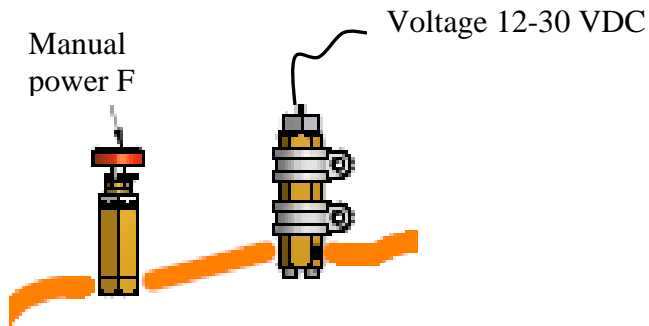

2.4 Extinguisher cylinder

On delivery the extinguisher cylinder is filled to approx 105 bar pressure. The propellant consists of nitrogen gas. The pressure can be read off on a manometer and shall be within the green sector. The extinguisher cylinder is also available in a version with two connected cylinders. It can be located in a red protection box. As an option there is a pressure switch that gives an alarm if the pressure falls below approx 80 bar.

The working temperature of the cylinder **must not exceed + 65°C!** See the round blue label for the anti freezing durability of the cylinder.

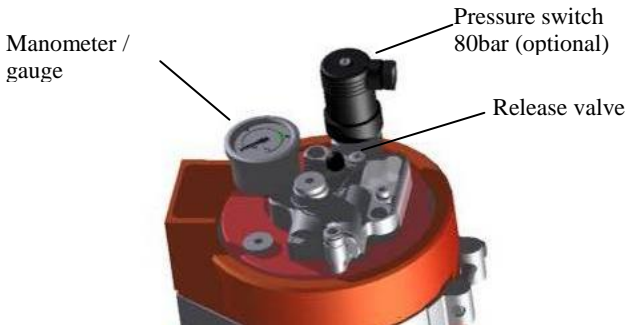



Older valve

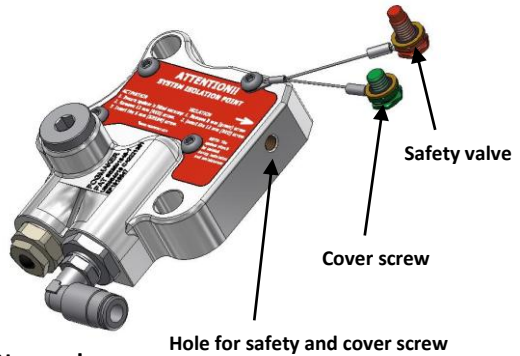

New valve

The extinguisher has a safety screw hanging on a wire when the system is active. The safety screw shall always be inserted before a service, installation/dismantling or when transporting the extinguisher when it is pressurized. The screw prevents unintentional activation of the extinguisher.

It is absolutely forbidden for non-authorized personnel to take any action on the extinguisher cylinder, primarily when it is pressurized. The pressure in the cylinder can then be released and can with great power injure a person seriously.

3. Alarm test

The fire alarm shall always be tested before the work period commences.



Press the test button with the engine fire lamp. When the test button is depressed the lamp shall be lit and an alarm sound shall be heard in the driver position.

4. In the event of a smoke alarm



In the event of a smoke alarm the lamp on the sign "*Smoke alarm*" will be lit and a constant sound will be heard. Check the passenger compartment for the cause.

5. In the event of a fire



In the event of a fire the red lamp marked with engine fire is lit and the alarm siren gives an intermittent sound.

If no fire has occurred and the system has not been triggered it indicates that there is too low a pressure in the extinguisher cylinder or the detector cylinder. Contact service personnel/workshop immediately.

- **If the vehicle is in premises with inflammable material move it if possible.**
- **Shut off engines and fans.**
- **Turn the contact key and the main power off.**
- **If possible close the cover to the engine compartment if it is open.**
- **For systems with manual activation with wires: break the seal, lift the safety shackle and pull powerfully on the wire handle.**
- **For systems with manual activation with a punch: pull out the safety pin, then press (hit) the release button heavily.**
- **Shut off the fuel supply to the engine.**
- **If required, use a hand extinguisher.**
- **Keep the engine cover closed for at least 5 minutes.**
- **Contact service personnel, contact the fire service if necessary.**

6. Low pressure alarm

In the event of an alarm for low pressure in the detector cylinder or extinguisher cylinder, contact service personnel.

7. Action after a fire

The fire alarm will sound until the alarm is actively shut off. This is done by contacting authorized service personnel. For systems with the Fogmaker bus alarm the alarm signal can be shut off by removing the cover of the pressure switch on the extinguisher and by twining together the two electrical cables. The pressure switch contacts on the detector cylinder are separated and strapped. Do not start the vehicle before the cause of the fire has been established and corrected.

The extinguishant does not normally affect the function of the engine. Starting difficulties can however occur for diesel engines since the extinguishant contains water. It is worth considering that the extinguishant can cause corrosion damage if the engine is not run within a short time after the fire. For the sake of safety the engine should be protected by filling a little oil and turning over the engine a couple of revolutions with the starter motor.

In order to avoid corrosion on metal parts and unwanted short circuiting in the electrical system, sanitation shall be carried out as soon as possible. This is done by rinsing with fresh water, preferably with medium/high pressure. Use Fogmaker washing fluid, otherwise a film that collects dirt can remain.

Always take notice of the vehicle manufacturer's instructions for engine washing.

8. Daily inspection of the extinguisher system

Check that possible lamps for low pressure in the extinguisher cylinder or detector cylinder are not lit. Check that the pressure in the extinguisher cylinder and the detector cylinder is within the green sector on the manometers. Control is discontinued for the pressure switches on the detector and extinguisher cylinders.

9. Annual control

The extinguisher system shall be controlled once a year by authorized personnel in accordance with the inspection report.

See service manual for detailed instruction and detailed form.

10. 5 year service and 10 year overhaul

Every fifth year the extinguishant shall be exchanged due to the characteristics of the product. Every tenth year the extinguisher cylinder shall undergo an overhaul where the extinguisher cylinder will be disassembled and checked for wear and damages.

5 year service and 10 year overhaul may only be carried out by authorized personnel.

Appendix 1

The following shall be documented by the vehicle manufacturer or by the installation technician after an installation:

Registration no.		Installation date	
Chassis no.		Installation technician Person, company	
Serial no. detector cylinder		Pressure (Bar) on delivery	
Serial no. extinguisher cylinder		Pressure (Bar) on delivery	

Inspection	Date	Person, Company
Year 1		
Year 2		
Year 3		
Year 4		
Year 5 Revision		
Year 6		
Year 7		
Year 8		
Year 9		
Year 10 Revision		

In order that the guarantee shall apply, this page and the first page shall be copied and sent to Fogmaker. (See first page for contact information).