

TYLER

A^{series} Advantage

Installation & Service Manual



Model NMWE Shown

NMW, NMWE, NMWEE

ISLAND FRESH MEAT MERCHANDISERS Medium Temperature Self Serve Display Cases

This manual has been designed to be used in conjunction with the
General (UL/NSF) Installation & Service Manual.

Save the Instructions in Both Manuals for Future Reference!!

This merchandiser conforms to the American National Standard Institute & NSF International Health and Sanitation standard ANSI/NSF 7 - 2003.

PRINTED IN U.S.A.	Specifications subject to change without notice.	REPLACES EDITION	1/04	ISSUE DATE	1/06	PART NO.	9037154	REV.	B
-------------------	--	------------------	------	------------	------	----------	---------	------	---

CONTENTS

	<u>Page</u>
Specifications	
NMW, NMWE, NMWEE Specification Sheets	4
Line Sizing Requirements (See General-UL/NSF I&S Manual)	
Pre-Installation Responsibilities (See General-UL/NSF I&S Manual)	
Installation Procedures	
Carpentry Procedures	6
Case Pull-Up Locations	6
Trim Installation/Alignment (See General-UL/NSF I&S Manual)	
Plumbing Procedures (See General-UL/NSF I&S Manual)	
Refrigeration Procedures (See General-UL/NSF I&S Manual)	
Electrical Procedures	6
Electrical Considerations	6
Defrost Information	7
Defrost Control Chart	7
Installation Procedure Check Lists (See General-UL/NSF I&S Man.)	
Wiring Diagrams	7
NMW/NMWE/NMWEE Domestic & Export (50Hz) Case Circuits	8
Cleaning and Sanitation (See General-UL/NSF I&S Manual)	
Component Removal and Installation Instructions for Cleaning	10
Screens	10
Bottom Trays	10
Perimeter Air Ducts	10
NSF Product Thermometer	10
Center and End Discharge Air Honeycombs	10
Center and End Discharge Duct Panels	10
Perimeter Cladding	10
Base Side and End Panels	10

	<u>Page</u>
General Information	
NSF Product Thermometer Installation	11
Radiant Heat Information	11
Service Instructions	
Preventive Maintenance (See General-UL/NSF I&S Manual)	
Color Band and Bumper Replacement (See Gen.-UL/NSF I&S Man.)	
Corner Trim Replacement	12
Perimeter Glass Replacement	12
Fan Blade and Motor Replacement	12
Fan Blade Replacement	13
Fan Motor Replacement	13
Anti-Sweat Replacement	14
Discharge Air Grid Anti-Sweat End Cases (NMWE/NMWEE)	14
Discharge Air Grid Anti-Sweat Center Riser (all models)	14
Defrost Heater Replacement	15
Parts Information	
Cladding and Optional Trim Parts Lists	16
NMW	16
NMWE	18
NMWEE	20
Operational Parts List	22
TYLER Warranty (See General-UL/NSF I&S Manual)	

The following Medium Temperature Island Fresh Meat Merchandiser models are covered in this manual:

MODEL	DESCRIPTION
NMW	6', 8' & 12' ISLAND MEAT MERCHANDISER WITHOUT ENDS
NMWE	9', 11' & 15' ISLAND MEAT MERCHANDISER WITH ONE END
NMWEE	12', 14' & 18' ISLAND MEAT MERCHANDISER WITH BOTH ENDS

SPECIFICATIONS

NMW/NMWE/NMWEE Island Fresh Meat Merchandiser Specification Sheets

Refrigeration Data:

MODEL	CASE LENGTH	CASE USAGE	CAPACITY (BTUH / FT)		EVAPORATOR (°F)	UNIT SIZING (°F)	DISCHARGE AIR		AVG. REF. CHARGE (LBS/FT)
			PARALLEL	CONVENTIONAL			TEMPERATURE (°F)	VELOCITY (FPM)	
NMW	6'8"/12'	MED TEMP	907*	1,020*	+10**	+8	+18	N/A***	0.47
NMWE	9'11"/15'	MED TEMP	829*	933*	+10**	+8	+18	N/A***	0.42
NMWEE	12'14"/18'	MED TEMP	852*	959*	+10**	+8	+18	N/A***	0.40

* For sizing all refrigeration equipment other than TYLER, use conventional BTUH values.
 ** Evaporator temperature is defined as the saturated suction temperature leaving the case.
 *** Air velocity measured 1 hour after defrost at the center riser discharge air duct using an ALNOR JR. velometer with a scoop.

FOR SPECIFIC COMPRESSOR SIZING AND/OR LINE SIZING INFORMATION, REFER TO THE "GOLD" AND/OR "BUFF" SECTIONS IN THE TYLER SPECIFICATION GUIDE.

Electrical Data:

Fans and Heaters (120 and 208 Volt)

MODEL	CASE LENGTH	FANS / CASE	TOTAL STANDARD FANS		TOTAL ECM FANS		TOTAL ANTI-SWEATS (120V)		DEFROST HEATER (208V)	
			AMPS	WATTS	AMPS	WATTS	DISCHARGE AIR AMPS	WATTS	AMPS	WATTS
NMW	6'	2	0.68	60.4	0.44	22.0	0.45	54.0	12.89	2,682
NMW	8'	2	0.68	60.4	0.44	22.0	0.60	72.0	13.75	2,860
NMW	12'	3	1.02	90.6	0.66	33.0	0.90	108.0	20.63	4,290
NMWE	9'	4	1.36	120.8	0.88	44.0	0.66	78.8	17.19	3,576
NMWE	11'	4	1.36	120.8	0.88	44.0	0.80	96.0	18.05	3,754
NMWE	15'	5	1.70	151.0	1.10	55.0	1.10	132.0	24.92	5,184
NMWEE	12'	6	2.04	181.2	1.32	66.0	0.85	102.0	21.49	4,470
NMWEE	14'	6	2.04	181.2	1.32	66.0	1.00	120.0	22.35	4,648
NMWEE	18'	7	2.38	211.4	1.54	77.0	1.30	156.0	29.22	6,078

Heaters (208 Volt)

FT	208 VOLT DEFROST (AMPS)													
	6	8	9	11	12	14	15	18	22	26	30	34	38	42
NMW/ NMWE 1 PH	13.0 TG-30	13.0 TG-30	17.8 TG-30	18.6 TG-30	20.6 TG-30	N/A	35.4 TG-50	N/A	N/A	N/A	N/A	N/A	N/A	N/A
NMWEE 1 PH	N/A	N/A	N/A	N/A	22.6 TG-30	23.4 TG-30	N/A	30.2 TG-40	37.2 TG-50	N/A	25.4/25.4 TG-30-30	N/A	25.4/13.8/25.4 TG-30-30-30	25.4/20.6/25.4 TG-30-30-30
NMWEE 3 PH	N/A	N/A	N/A	N/A	N/A	N/A	N/A	N/A	33.0 TG-3-40	38.0 TG-3-50	N/A	34.0 TG-3-40	N/A	N/A

Defrost Data:

DEFROST TYPE*	DEFROSTS PER DAY	DURATION TIME (MIN)	TERMINATION (°F)	EPR SETTINGS **		DEFROST WATER (LB / FT / DAY)		
				R22 (PSIG)	R404A (PSIG)	NMW	NMWE	NMWEE
TIME OFF	4	40	---	33	44	N/A	N/A	N/A
ELECTRIC	4	40	50					
HOT GAS	4	20	55*					

* If an Electronic Sensor is used for termination, it should be set at 70°F termination temperature. The sensor must be located in the same location as the defrost termination klaxon for that defrost type.
 ** Set EPR to give this pressure at the case.

MODEL	CASE-TO-CASE SUCTION LINE SUB-FEED BRANCH LINE SIZING													
	6'	8'	9'	11'	12'	14'	15'	18'	22'	26'	30'	34'	38'	42'
NMW	5/8"	5/8"	N/A	N/A	7/8"	N/A	N/A	N/A	N/A	N/A	N/A	N/A	N/A	N/A
NMWE	N/A	N/A	5/8"	7/8"	N/A	N/A	7/8"	N/A	N/A	N/A	N/A	N/A	N/A	N/A
NMWEE	N/A	N/A	N/A	N/A	5/8"	5/8"	N/A	7/8"	7/8"	7/8"	7/8"	7/8"	7/8"	1 1/8" 1 1/8"

UL SANITATION approved in accordance with ANSI/NSF – 7.

CASE BTUH REQUIREMENTS are calculated to produce approximately the indicated entering-air temperature with absolute maximum operating ambient limits of 75°F & 55RH

The information contained herein is based on technical data and tests that we believe are reliable, and is intended for use by persons having technical skill at their own discretion and risk. Since conditions of use are outside of Tyler's control, we cannot assume any liability for results obtained or damages incurred through the applications of the data presented. SPECIFICATIONS ARE SUBJECT TO CHANGE WITHOUT NOTICE.

NMW/NMWE/NMWEE CROSS SECTION

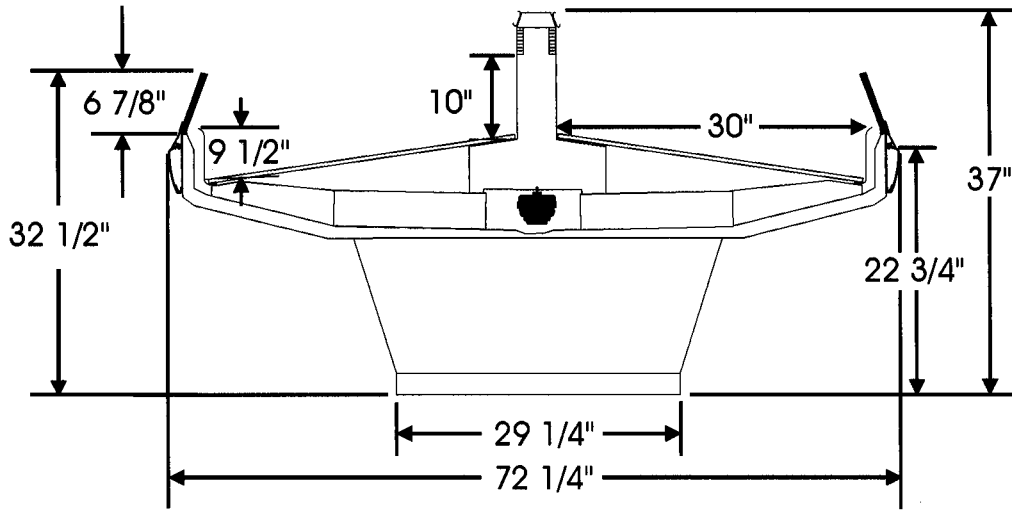

NMW FLOOR PLAN

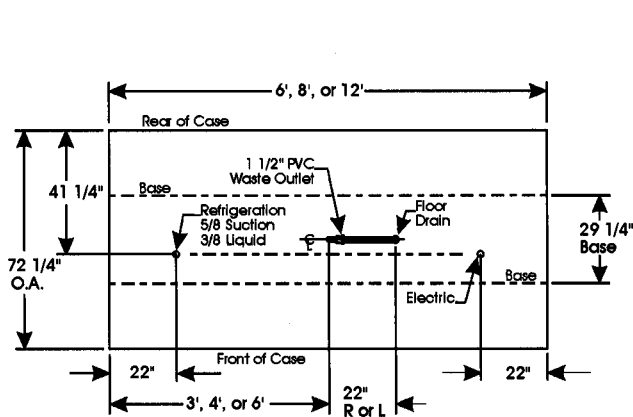

NMWE FLOOR PLAN

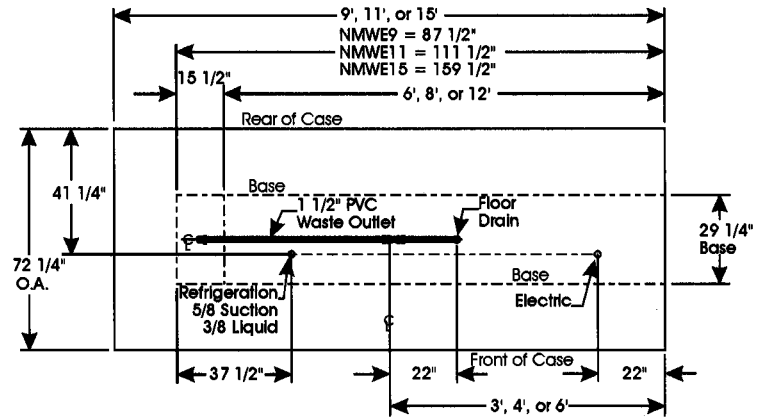

NMWEE FLOOR PLAN

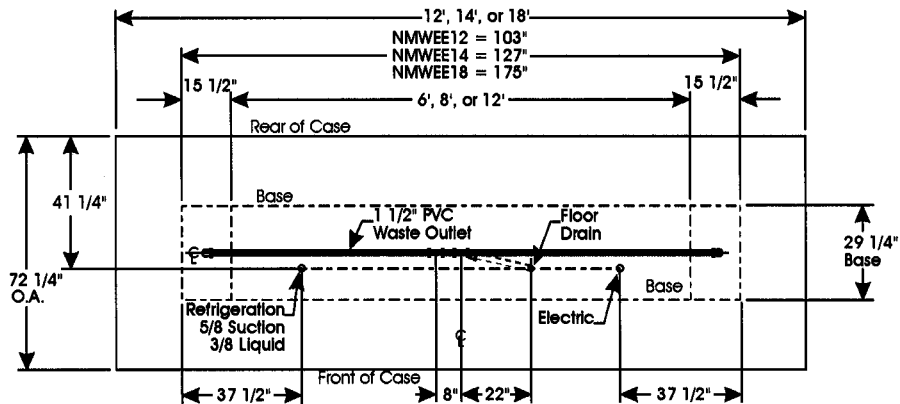

INSTALLATION PROCEDURES

Carpentry Procedures

Case Pull-Up Locations

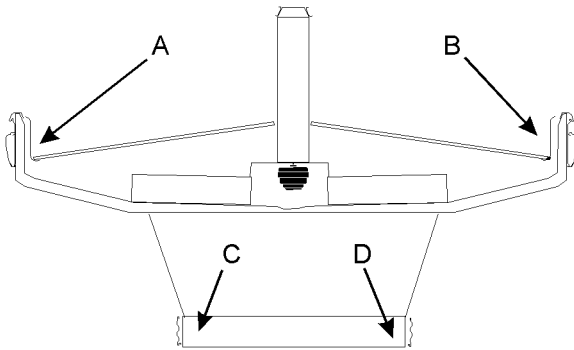

The NMWEE models do not have any open ends, therefore no pull-ups are required. All other NMW models have four pull-ups at each open end of the case. Pull-ups A, B, C and D are located as shown and used for joining end cases. All pull-ups should be installed and tightened starting with A and finishing with D.

See "General-UL/NSF I&S Manual" for line-up assembly and color band & bumper installation instructions.

After all case pull-ups have been secured, install the bottom trays and the case screens.

Refrigeration Procedures

See "General-UL/NSF I&S Manual" for refrigeration procedure information.

Electrical Procedures

Electrical Considerations

CAUTION

Make sure all electrical connections are tight. This prevents burning of electrical terminals and/or premature component failure.

Case Fan Circuit

This circuit is to be supplied by an uninterrupted, protected 120V circuit. The case fan circuit is not cycled, except when equipped for gas defrost. On gas defrost cases the fan circuit is controlled by a 50/40 klixon.

NOTE

With gas defrost, the fans will not start until the coil temperature reaches 40°F at the fan delay thermostat.

Anti-Sweat Circuit

NMW cases have two anti-sweat heaters for the center discharge air grid. NMWE cases have two anti-sweat heaters for the center discharge air grid and an additional anti-sweat heater for the end case discharge air grid. NMWEE cases have two anti-sweat heaters for the center discharge air grid and two additional anti-sweat heaters for the end case discharge air grids. Anti-sweat heaters are wired directly to the main power supply so they can operate at all times.

Defrost Information

See "General-UL/NSF I&S Manual" for operational descriptions for each type of defrost control.

Defrost Control Chart

Defrost Type	Defrosts Per Day	Defrost	
		Duration (Min)	Term. Temp.
Off Time	4	40	-----
Electric	4	40	50°F
Gas	4	20	55°F

All klixons are located on the right end of the evaporator coils. The diagram shows the location for each defrost type that uses a klixon.

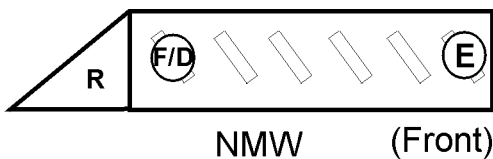

E = Electric Defrost Termination
 F/D = Gas Defrost (Fan Delay)

NOTE

The Gas Defrost Termination klixon is located on the bypass check valve.

CAUTION

If electronic sensors are used in place of the klixons, the sensors must be located in the same locations as the klixons for that defrost type. Any other locations will effect the refrigeration efficiency of the case.

WIRING DIAGRAMS

ELECTRICIAN NOTE - OVERCURRENT PROTECTION

120V circuits should be protected by 15 or 20 Amp devices per the requirements noted on the cabinet nameplate or the National Electrical Code, Canadian Electrical Code - Part 1, Section 28. 208V defrost circuits employ No. 12 AWG field wire leads for field connections. On remote cases intended for end to end line-ups, bonding for ground may rely upon the pull-up bolts.

The following wiring diagrams on pages 8 and 9 will cover the NMW/NMWE/NMWEE case circuits with electric and gas defrost.

1. TYLER REFRIGERATION CORP. CLAIMS RIGHTS TO THE INFORMATION ON THIS DRAWING.
 2. INFORMATION IS TO BE ENGINEERED ONLY.
 3. ALL DIMENSIONS ARE IN INCHES UNLESS SPECIFIED OTHERWISE.
 4. DIMENSIONS APPLY TO FINISHED PART AFTER MOUNTING.
 5. NO MANUAL REVISIONS ALLOWED.

PART TYPE	N	T	S
MODEL	FABRICATED X		
PURCHASED	DEPT		
DEPT	CC	W	

OPTIONAL SOLENOID VALVE

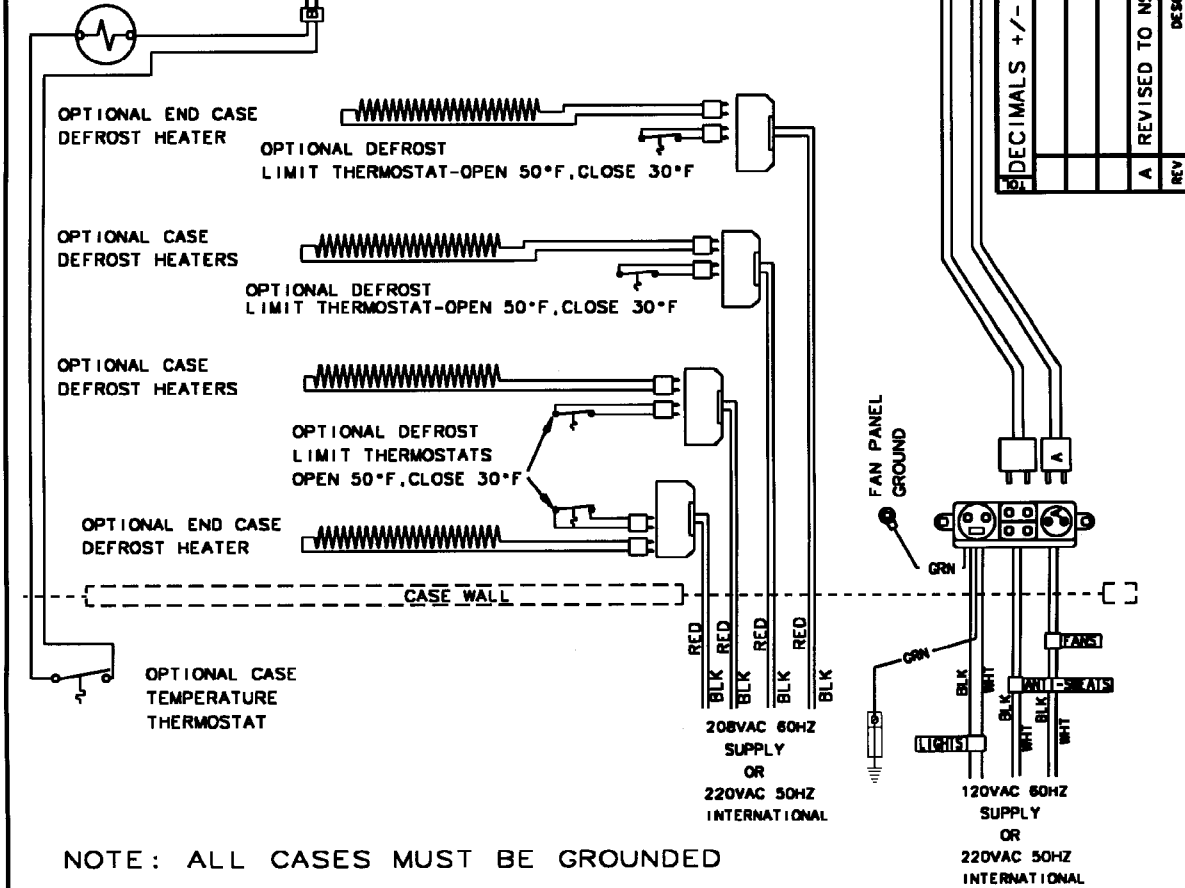

NOTE: ALL CASES MUST BE GROUNDED

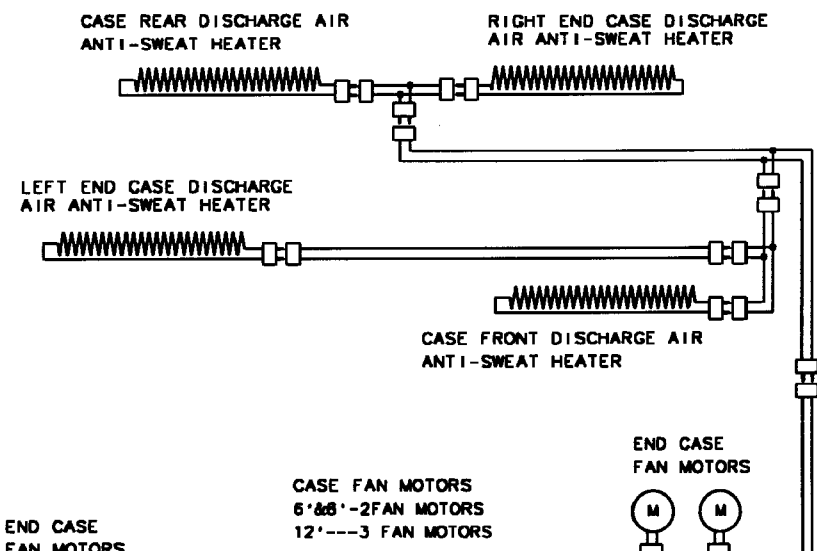

NAME	14 SEPT 199		
DATE	LC	CK	24702
REL	LC	CK	24702
REF	LC	CK	24702
REV	DATE	RELEASE	DESCRIPTION
A	17OCT00	26302	REVISED TO NSF MODEL
B			DECIMALS +/- .030 ANGLES +/- 1 DEGREE

DIAGRAM WRG NMW(E)
 (EE) OC OR ELEC DFR

9036870

REV A

CLEANING AND SANITATION

Component Removal and Installation Instructions for Cleaning

Screens

1. Remove product from screens.
2. Push screens up until bottom screen tabs clear the holes in the front duct.
3. Remove screens from holes in rear duct panels and from case.
4. After cleaning, replace in reverse order.

Bottom Trays

1. Remove product and screens from case. See this page.
2. Grasp and lift out each of the bottom trays from the case interior.
3. After cleaning, replace in reverse order.

Perimeter Air Ducts

1. Remove screens and bottom trays, see this page.
2. Lift out perimeter air duct sections and carefully remove from case.
3. After cleaning, replace in reverse order.

NSF Product Thermometer

Remove two screws and product thermometer/bracket assembly from end left side perimeter air duct section. After cleaning, replace product thermometer/bracket assembly and secure with two screws.

NOTE

The product thermometer must always be located at the end on the left side of the case.

Center and End Discharge Air Honeycombs

1. Remove screws and grid retainer assembly.

NOTE

Note position of honeycomb grid sections during removal so they can be reinstalled the same way.

2. Remove honeycomb grid sections from the discharge air duct.

CAUTION

Improper installation of the honeycomb grid sections could result in improper air flow and/or poor refrigeration.

3. After cleaning, replace honeycomb grid sections as they were removed and secure with grid retainer assembly and screws.

Center and End Discharge Duct Panels

1. Remove product, screens and bottom trays, see this page.
2. Remove all mounting screws and rear and end discharge duct panels from case.
3. After cleaning, replace in reverse order.

Perimeter Cladding

1. Remove all mounting screws, upper cladding joint trims and lower corner trim assemblies. from case.
2. Remove mounting screws and bumper corner trim from case corners.
3. Remove color bands, bumpers and hand rail/bumper retainers from case. See "General-UL/NSF I&S Manual".
4. Remove mounting screws and front cladding from sides of case.
5. Remove mounting screws and end cladding from case ends.
6. After cleaning, replace in reverse order.

Base Side and Base End Panels

1. Remove all mounting screws lower base joint trim from case.
2. Remove all mounting screws and base side panels from sides of case.
3. Remove all mounting screws and base end panels from case ends.
4. After cleaning, replace in reverse order.

GENERAL INFORMATION

NSF Product Thermometer Installation

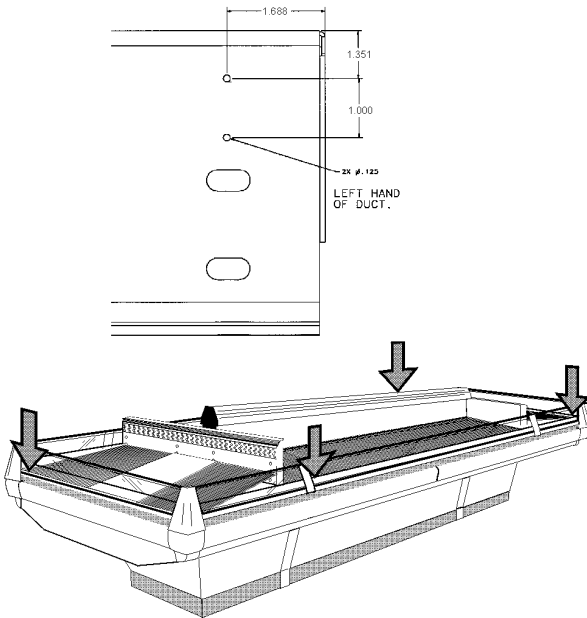

1. Remove end perimeter air duct section from left side of case.
2. Measure and mark removed air duct section as shown.
3. Drill two .125" holes at marked locations.
4. Install product thermometer/bracket assembly on air duct section with two screws.

Radiant Heat Information

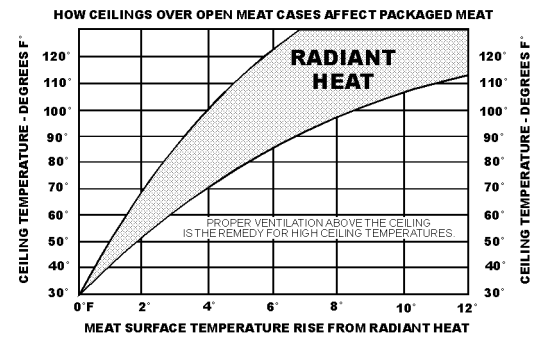
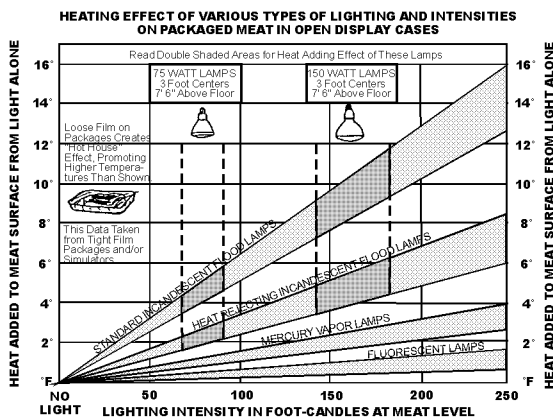

A wide temperature range is shown for each type of lighting. This data does not show all situations. Many situations will have higher package warm-up figures than indicated.

It is generally known that the temperature of displayed meat in refrigerated cases will run higher than the circulated air temperature of the cases. A dial thermometer stuck into the center of a piece of meat compared with one in the air stream quickly confirms this fact. Another fact is that the surface temperature of the meat will be higher than the center temperature due to radiant heat. TYLER's ongoing research identifies sources of radiant heat and accurately measures and records it. These charts were developed from the information gathered during this research. Two major sources of radiant heat are from display lights and ceiling surfaces. Additional heat sources come from bad display practices which either overload the case with product or allow voids in the product display. Poor display practices impair the efficiency of the refrigeration, adding to the surface temperature of the meat. Bacteria and molds grow when surface temperatures rise above 45°F. This prematurely discolors displayed meats and causes unnecessary meat department losses.

Radiant Heat Measurement

Place two accurate dial thermometers side by side in a case. Cover one of the thermometer stems with black friction tape. The temperature difference is the approximate amount of radiant heat. A change in display lighting or a reduction of high ceiling temperatures (over 80°F) could reduce the radiant heat in the case.

Display Practices

Encourage butchers to maintain all meat below the case load lines and to eliminate product voids. Case screens could be covered in some instances to keep the refrigerated air over the display.

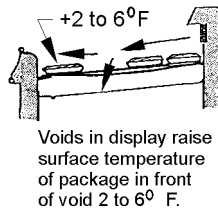

CAUTION

The quality damage done to meat products by high temperatures and/or contamination during delivery, cooler storage, cutting and wrapping cannot be repaired by placing the products into properly operating display cases.

SERVICE INSTRUCTIONS

Corner Trim Replacement

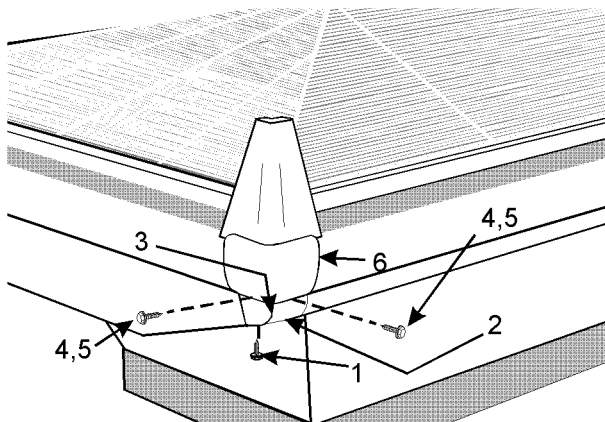

1. Remove two screws (1) and lower corner trim assembly (2) from corner of the case (3).
2. Remove two screws (4), two washers (5) and lift off the upper corner trim (6).
3. Replace upper and lower corner trim in the reverse order.

Perimeter Glass Replacement

NOTE

End cases require corner trim removal before replacing the glass. See "Corner Trim Replacement" in this manual.

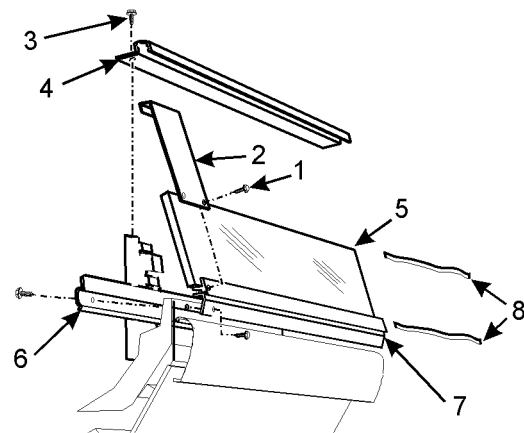

1. Remove two screws (1) and glass joint trim (2) from both joints of the broken glass.
2. Remove screws (3) and glass trim rail (4) from top of glass (5).
3. Loosen rear retainer (6) and remove broken glass from glass retainer assembly (7).
4. Apply sealant tape (8) to top and bottom edge of new glass (5).
5. Position new glass (5) in glass retainer assembly (7) and secure by tightening rear retainer (6).
6. Install glass trim rail (4) with screws (3) over top edge of new glass (5).
7. Install glass joint trim (2) with screws (1) over the joint areas of glass (5).

Fan Blade and Motor Replacement

WARNING

Shut off or disconnect power supply to case before servicing a fan. Automatic cycling of fan or electrical power to wire ends could cause personal injury and/or death.

Fan Blade Replacement

1. Remove screens and bottom trays from case.

CAUTION

Electrical wiring to fan circuit is still connected. Careless removal could damage the wiring.

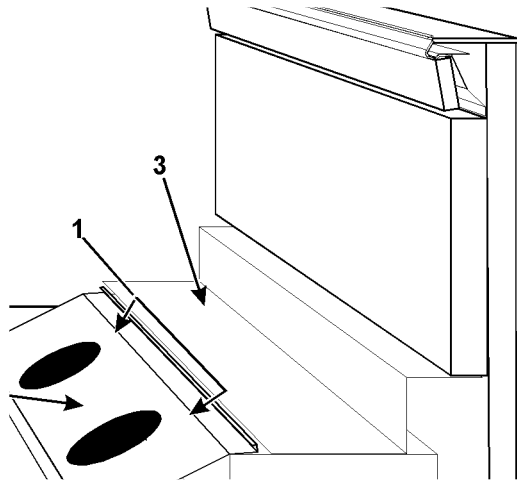

2. If removing center fan blade, turn thumb-screws (1) and carefully lift out the fan plenum (2) from under the center riser (3).

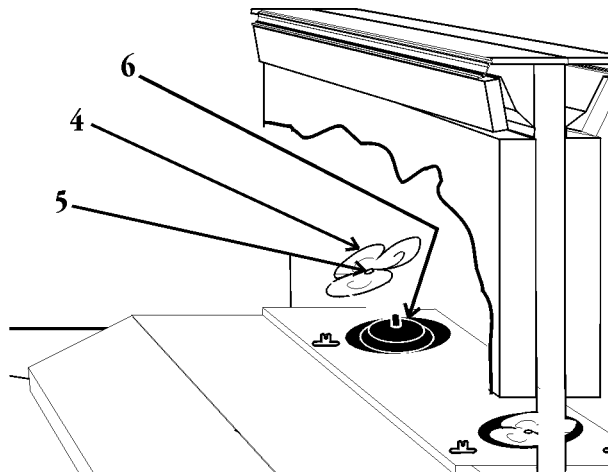

3. To replace fan blade (4), remove spring clip or nut (5) and fan blade (4) from fan motor shaft (6). Discard spring clip or nut.

NOTE

Center and end fan blades are not interchangeable. Each location requires specific blades for proper case operation.

4. Install new fan blade (4) on fan motor shaft (6) and secure with new spring clip or new nut (5).
5. Replace center fan plenum, bottom trays and screens in case.

Fan Motor Replacement

1. Remove screens and bottom trays from case.

CAUTION

Electrical wiring to fan circuit is still connected. Careless removal could damage the wiring.

2. If removing center fan motor, turn thumb-screws and carefully lift out the fan plenum from under the center riser. See illustration under "Fan Blade Replacement" on this page.

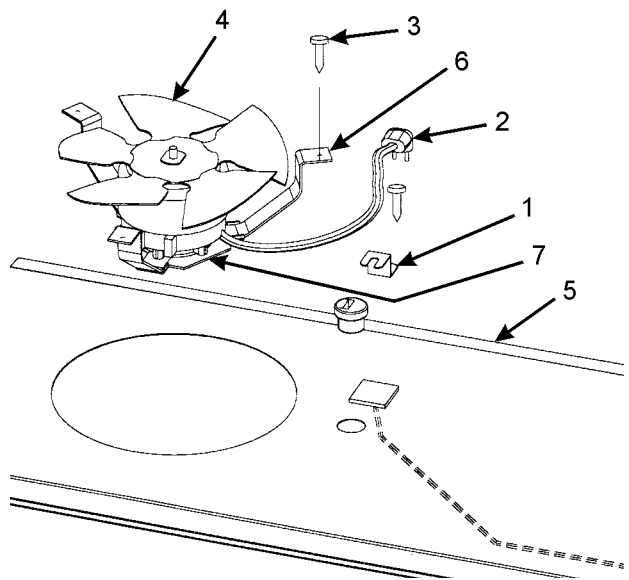

3. Remove fan harness clip and disconnect fan motor plug (1) for the defective fan.
4. Remove three screws and lift out fan motor and bracket assembly (2) from fan plenum (3).
5. Remove three screws, fan bracket plate (4) and mounting brackets (5) from fan motor assembly (2).

NOTE

If replacement blades and/or motor are not available, unplug motor and cover opening until the replacement parts are available.

6. Replace new fan motor assembly in reverse order.

Anti-Sweat Replacement

WARNING

Shut off or disconnect power supply to case before changing an anti-sweat. Electrical power from wire ends could damage other components and/or cause personal injury or death.

Discharge Air Grid Anti-Sweat End Cases (NMWE/NMWEE)

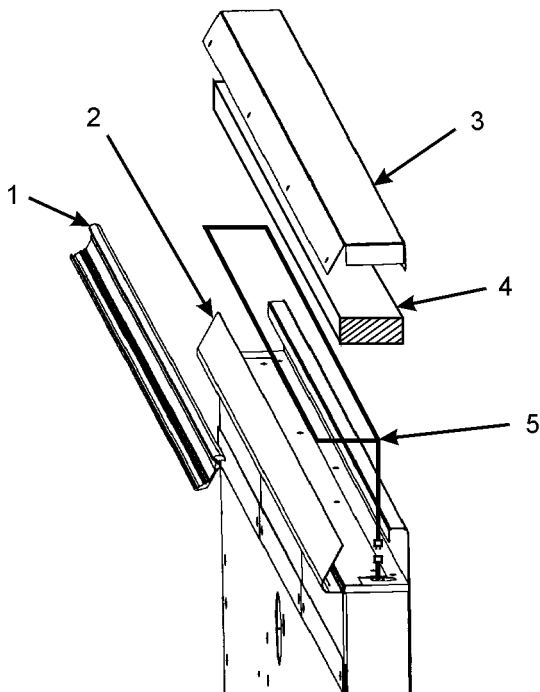

1. Remove screws and card molding (1) from rear riser (2).
2. Remove screws, riser cap trim (3) and insulation (4) from rear riser (2).
3. Disconnect anti-sweat wires from case wires.
4. Remove and replace aluminum tape and defective anti-sweat heater (5) in top of rear riser (2).

5. Connect the anti-sweat wires to the case wires and reinstall the insulation (4).
6. Install the riser cap trim (3) and card molding (1) and secure with screws.

Discharge Air Grid Anti-Sweat Center Riser (all models)

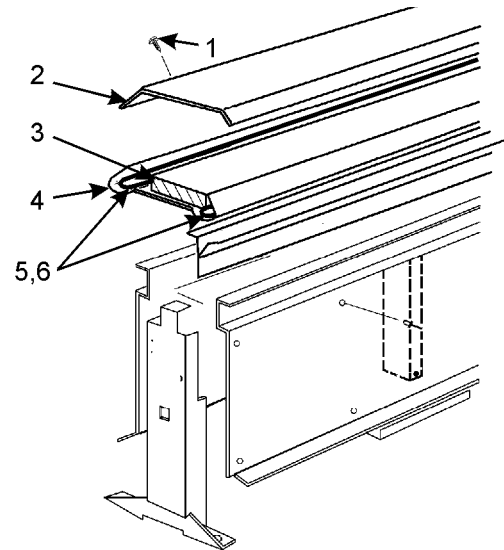

1. Remove screws (1), center riser trim (2) and insulation (3) from top of the center riser (4).
2. Disconnect anti-sweat wires from case wires.
3. Remove and replace the aluminum tape (4) and the anti-sweat heater (5) in top of the center riser (3).
4. Connect the anti-sweat wires to the case wires and reinstall the insulation (2).
5. Install center riser trim (2) with screws (1).

Defrost Heater Replacement

WARNING

Always shut off electricity to case before replacing a defrost heater. Automatic cycling of fans or electrical power to wire ends could cause personal injury and/or death.

1. Remove screens and bottom trays from case.

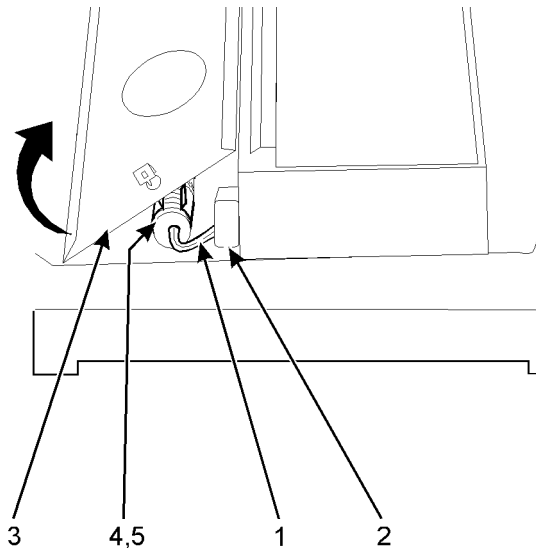

2. Disconnect defrost heater plug (1) from junction block (2).
3. Remove screws and lift up coil cover (3).
4. Remove defective defrost heater (4) from mounting clips (5) and case.
5. Install new defrost heater (4) and reinstall coil cover (3) in reverse order.
6. Replace bottom trays and screens in case. Restore electrical power to case.

PARTS INFORMATION

Cladding and Optional Trim Parts Lists

Item Description	6'	NMW 8'	12'
1 Riser Top Joint Trim	5225680	5225680	5225680
2 Screw	5048626 (4)	5048626 (4)	5048626 (4)
3 Riser Lower Joint Trim	5227162 (2)	5227162 (2)	5227162 (2)
4 Screw (per side)	5048626 (2)	5048626 (2)	5048626 (2)
5 Glass Joint Trim	9025959 (2)	9025959 (2)	9025959 (2)
6 Screw (per trim)	5612692 (2)	5612692 (2)	5612692 (2)
7 Color Band, Painted	9020968 (2)	9020971 (2)	9020972 (2)
8 Color Band Backer, Painted	9025982 (2)	9025982 (2)	9025982 (2)
9 Bumper End Trim	-----	color per order	-----
10 Screw (per cladding joint trim)	5205439 (2)	5205439 (2)	5205439 (2)
11 Cladding Joint Trim	9027501 (2)	9027501 (2)	9027501 (2)
12 Bumper	-----	color per order	-----
13 Front Cladding, Painted	9025633 (2)	9025634 (2)	9025635 (2)
14 Screw (per cladding side)	5048626 (8)	5048626 (14)	5048626 (18)
15 Bumper Retainer	9025052 (2)	9025058 (2)	9025061 (2)
16 Screw (per bumper retainer)	9025833 (12)	9025833 (18)	9025833 (24)
17 Horizontal Joint Trim	5215379	5215379	5215379
18 Base Side Panel Joint Trim	5952796 (2)	5952796 (2)	5952796 (2)
19 Screw (per base side joint trim)	5205439 (4)	5205439 (4)	5205439 (4)
20 Lower Base Joint Trim	5227395 (2)	5227395 (2)	5227395 (2)
21 Screw (per lower base joint trim)	5145036 (2)	5145036 (2)	5145036 (2)

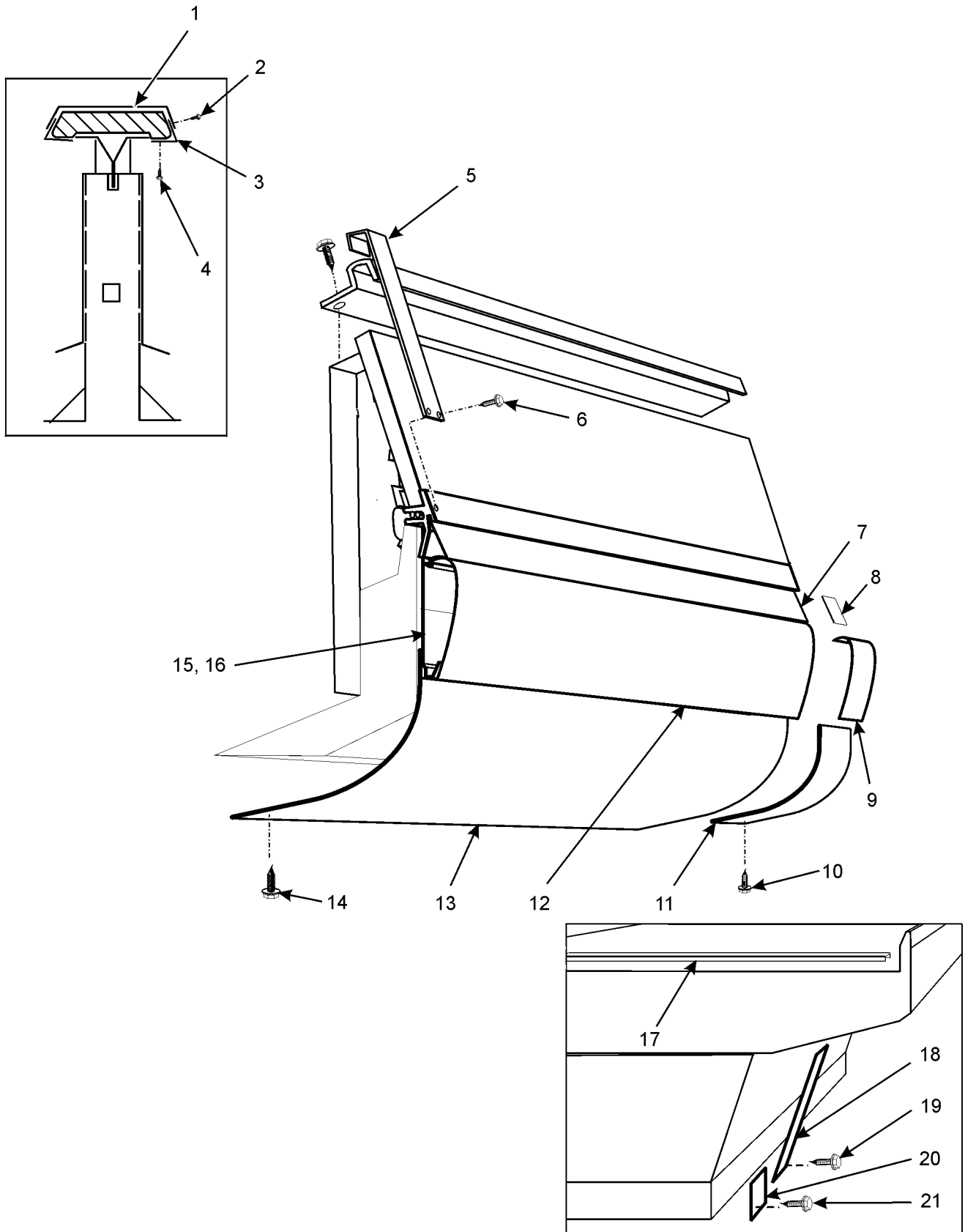

Item Description	NMWE		
	9'	11'	15'
1 Riser Top Joint Trim	5225680	5225680	5225680
2 Screw	5048626 (4)	5048626 (4)	5048626 (4)
3 Riser Lower Joint Trim	5227162 (2)	5227162 (2)	5227162 (2)
4 Screw (per side)	5048626 (2)	5048626 (2)	5048626 (2)
5 Horizontal Joint Trim	5215379	5215379	5215379
6 Glass Joint Trim	9025959 (2)	9025959 (2)	9025959 (2)
Screw (per trim)	5612692 (2)	5612692 (2)	5612692 (2)
7 Color Band Backer, Painted	9025982 (2)	9025982 (2)	9025982 (4)
8 Bumper Backer	-----	color per order	-----
9 Cladding Joint Trim	9027501 (2)	9027501 (2)	9027501 (2)
Screw (per cladding joint trim)	5205439 (2)	5205439 (2)	5205439 (2)
10 Base Side Panel Joint Trim	5952796 (2)	5952796 (2)	5952796 (2)
Screw (per base side joint trim)	5205439 (4)	5205439 (4)	5205439 (4)
11 Lower Base Joint Trim	5227395 (2)	5227395 (2)	5227395 (2)
Screw (per lower base joint trim)	5145036 (2)	5145036 (2)	5145036 (2)
12 Front Cladding, Painted	9023173 (2)	9031452 (2)	9031453 (4)
Screw (per cladding side)	5048626 (8)	5048626 (8)	5048626 (6)
13 Bumper (per side)	-----	color per order	-----
Bumper Retainer	9028395 (2)	9028396 (2)	9028394 (4)
Screw (per bumper retainer)	9025833 (18)	9025833 (22)	9025833 (16)
14 Color Band, Painted	9028405 (2)	9028406 (2)	9028404 (4)
15 End Case Front Cladding, Painted	9027492	9027492	9027492
Screw (per end case front cladding)	5048626 (4)	5048626 (4)	5048626 (4)
16 End Case Front Bumper	-----	color per order	-----
End Case Front Bumper Retainer	9025820	9025820	9025820
Screw (per end case front bmpr rtnr)	9025833 (12)	9025833 (12)	9025833 (12)
17 End Case Front Color Band, Painted	9020967	9020967	9020967
18 Lower Corner Trim Assembly, Painted	9027496 (2)	9027496 (2)	9027496 (2)
19 Bumper Corner Trim (per corner)	-----	color per order	-----

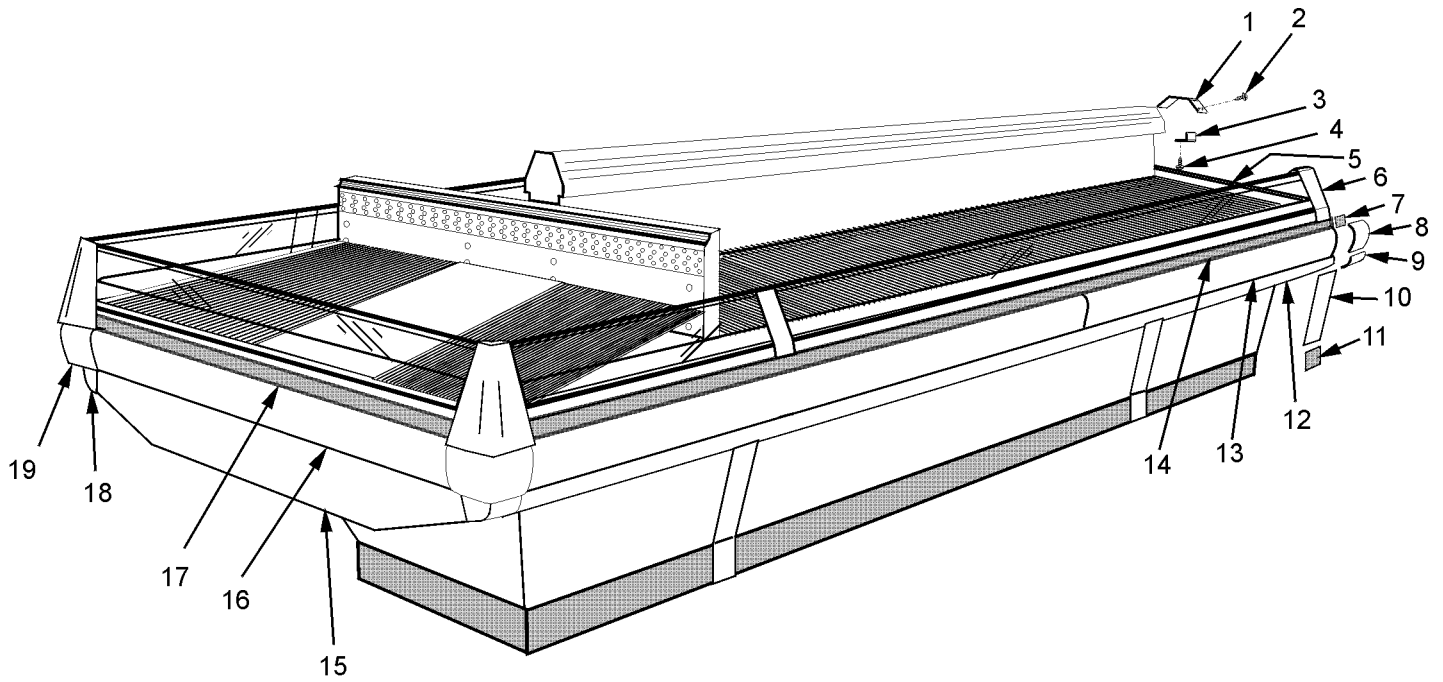

Item Description	NMWEE		
	12'	14'	18'
1 Color Band Backer, Painted	----	9025982 (2)	9025982 (4)
2 Bumper Backer (14'-qty. 2/18'-qty. 4)	----	color per order	
3 Cladding Joint Trim	----	9027501 (2)	9027501 (2)
4 Screw (per cladding joint trim)	----	5205439 (2)	5205439 (2)
5 Glass Joint Trim	----	9025959 (4)	9025959 (4)
6 Screw (per glass joint trim)	----	5612692(2)	5612692(2)
7 Color Band, Painted	9028407 (2)	9028403 (4)	9028405 (4)
8 Bumper (per side)	-----	color per order	
Bumper Retainer	9028397 (2)	9028393 (4)	9028395 (4)
Screw (per bumper retainer)	9025833 (24)	9025833 (14)	9025833 (18)
9 Front Cladding, Painted	9023134 (2)	9023175 (4)	9023173 (4)
Screw (per cladding side)	5048626 (10)	5048626 (9)	5048626 (8)
10 Screw (per base side joint trim)	5205439 (4)	5205439 (4)	5205439 (4)
11 Screw (per lower base joint trim)	5145036 (2)	5145036 (2)	5145036 (2)
12 Lower Base Joint Trim	5227395 (4)	5227395 (4)	5227395 (4)
13 Base Side Panel Joint Trim	5952796 (4)	5952796 (4)	5952796 (4)
14 End Case Front Cladding, Painted	9027492 (2)	9027492 (2)	9027492 (2)
Screw (per end case front cladding)	5048626 (4)	5048626 (4)	5048626 (4)
15 End Case Front Bumper	-----	color per order	
End Case Front Bumper Retainer	9025820 (2)	9025820 (2)	9025820 (2)
Screw (per end case front bmpr rtnr)	9025833 (12)	9025833 (12)	9025833 (12)
16 End Case Front Color Band, Painted	9020967 (2)	9020967 (2)	9020967 (2)
17 Lower Corner Trim Assembly, Painted	9027496 (4)	9027496 (4)	9027496 (4)
18 Corner Glass Trim Assy. (per corner)	-----	color per order	

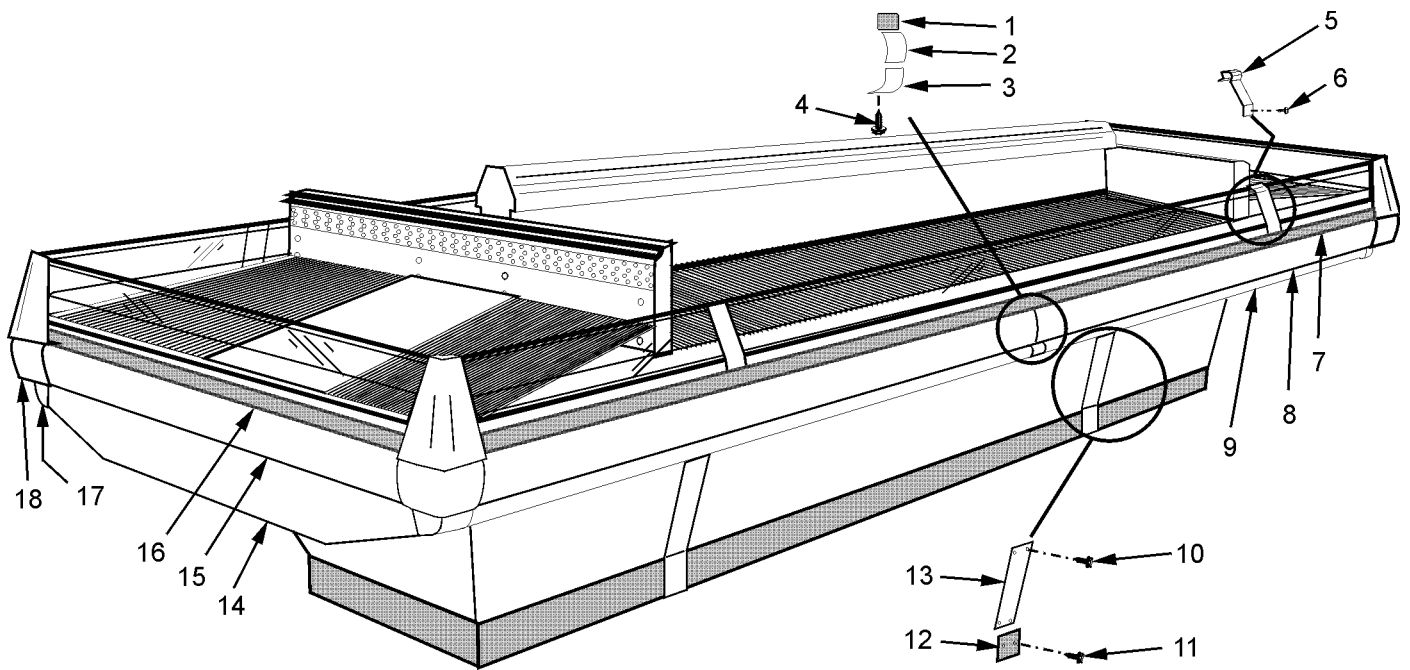

Operational Parts List

Case Usage	Domestic			
Electrical Circuit	115 Volt 60 Hertz			
Case Size	6'	8'	12'	End Case
Fan Motor	5125532 5 Watt	5125532 5 Watt	5125532 5 Watt	5125532 5 Watt
Fan Blades (7" 30° 5B)(NMW)	5227302	5227302	5227302	----
(7" 15° 5B)(NMWE/NMWEE)	----	----	----	9036378
Fan Motor Brackets	5962268	5962268	5962268	5962269
Fan Bracket Plate (all fans)	9041077	9041077	9041077	9041077
Opt. ECM Fan Motor	9025002 8 Watt	9025002 8 Watt	9025002 8 Watt	9025002 8 Watt
Opt. ECM Fan Blades (7" 20° 5B)(NMW)	5223396	5223396	5223396	----
(7" 15° 5B)(NMWE/NMWEE)	----	----	----	5223891
Opt. ECM Fan Motor Brackets	9025005	9025005	9025005	9025005
Anti-Sweat Heater (discharge air)	5227379(2)	5124216(2)	5124217(2)	5136615
Opt. Elec. Def. Heater	5125153	5124521	5124522	5109046
Opt. Elec. Def. Limit Switch (50/30 klixon)	5125211	5125211	5125211	5125211
Opt. Gas Def. Fan Delay Switch (50/40 klixon)	9023503	9023503	9023503	9023503
Opt. Gas Def. Term. T'stat (55/40 klixon)	9023508	9023508	9023508	9023508
NSF Product Thermometer	5967100	5967100	5967100	5967100

For information on operational parts not listed above contact the TYLER Service Parts Department.