



Operation & Service Manual



Model: 08-4048-0013
Engine Compressor Washer



05/2008 - Rev. 01

Includes Illustrated Parts List

REVISION
01

DATE
05/2008

TEXT AFFECTED
Original Release

TABLE OF CONTENTS

	<u>PAGE</u>
SCHEMATIC	1
1.0 GENERAL DESCRIPTION	2
2.0 OPERATION	2
2.1 PREPARATION & OPERATION	2
2.1.1 Preparation	2
2.1.2 Fluid Agitation	2
2.1.3 Cleaning Operation	2
2.1.4 Rinse Operation	2
3.0 MAINTENANCE & STORAGE	3
3.1 CLEANING FLUID TANKS	3
3.2 HOSES	3
3.3 AIR TANK MAINTENANCE	3
3.4 OUTPUT FILTER	3
3.5 STORAGE	3
4.0 IN-SERVICE SUPPORT	3
5.0 GUARANTEES/LIMITATION OF LIABILITY	3
6.0 PROVISION OF SPARES	4
6.1 SPARE PARTS	4
6.2 PARTS LIST	4

Schematic

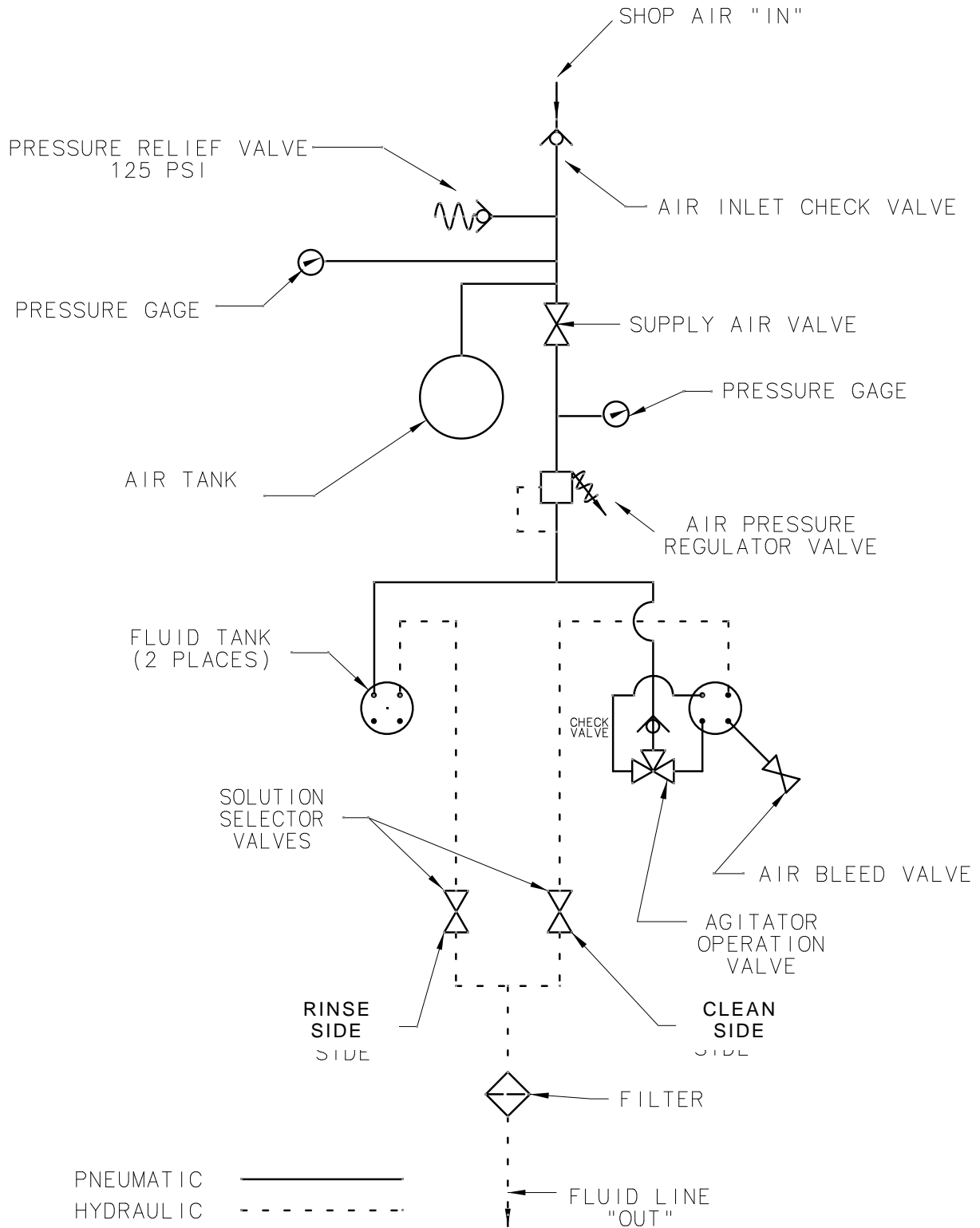

This product can not be modified without the written approval of Tronair, Inc. Any modifications done without written approval voids all warranties and releases Tronair, Inc., its suppliers, distributors, employees, or financial institutions from any liability from consequences that may occur. Only Tronair OEM replacement parts shall be used.

1.0 GENERAL DESCRIPTION

The Engine Compressor Washer is a portable unit designed to spray either cleaning solution and/or clean fresh water into jet and turboprop engines.

The two fluid tanks will hold seven (7) gallons each. The air tank, when charged to 125 psi, provides sufficient volume to empty both fluid tanks. The nozzle mounted on the panel may be installed on the wand to regulate the fluid flow to the approximate rate as indicated.

2.0 OPERATION



WARNING!

Personal injury may result if procedures are not followed!

- a) **Never open fluid tank while under pressure.**
- b) **Never pressurize air tank more than 125 psi.**
- c) **Thoroughly read and understand this manual before using equipment.**



CAUTION!

- a) **Use only clean water and/or cleaning fluids approved by engine manufacturer.**
- b) **Consult aircraft manual for correct procedure in performing engine wash.**

2.1 PREPARATION & OPERATION

Follow engine manufacturer's recommendations for cleaning and rinsing engine(s). Use only engine manufacturer's approved fluids.

2.1.1 Preparation

1. Visually inspect unit for any signs of shipping damage or missing parts.
2. Ensure supply air valve on Control Panel is in the closed (Off) position.
3. Open air bleed to depressurize solution tanks.
4. Remove solution tank lids and fill respective tank with desired amount of fluid.
5. Close solution tank lids.
6. Attach shop air to air fill valve on Control Panel and charge air tanks to 125 psi (8.6 bars) maximum.
7. Unit is now ready for immediate use. If unit stands idle, agitate fluid before use.

2.1.2 Fluid Agitation

NOTE: Reference to the Agitation circuit being "ON" means the Agitation Operation (3-way) valve handle is pointing to the left (9 o'clock position), and "OFF" means the valve handle is pointing to the right (3 o'clock position). The valve must either be in the "ON" or "OFF" position to pressurize solution tank.

1. Fully charge air supply tanks. Turn on agitation operation valve and ensure supply air valve is in the off position (closed).
2. Open air bleed valve on top of solution tank.
3. Set regulator to desired agitation pressure (30 psi recommended).
4. Slowly open supply air valve. When suds start coming out of the air bleed valve, or desired agitation is reached, close air bleed valve and turn off the agitation operation valve.

2.1.3 Cleaning Operation

1. Ensure tanks are charged and rinse and clean selector valves are closed.
2. Connect output hose to engine or wand assembly.
3. Open supply air valve.
4. Adjust cleaning pressure by adjusting air regulator on Control Panel per engine manufacturer's recommendations.
5. Turn clean selector valve to Open when ready to start cleaning.
6. If using wand, point wand away from personnel and turn on wand valve to start cleaning process.
7. Upon completion of cleaning (or if tank has been emptied), turn wand valve off and/or close clean selector valve on Control Panel.

NOTE: Agitator operation valve must be OPEN during use. Failure to do so may result in cleaning solution being discharged during rinse operation.

2.1.4 Rinse Operation

1. Adjust rinsing pressure by adjusting air regulator on Control Panel per engine manufacturer's recommendations.
2. Turn rinse selector valve to Open position on the Control Panel to start rinse.
3. If using wand, point wand away from personnel and turn on wand valve to start rinse process.
4. After completion of rinsing, turn wand valve Off and/or close rinse selector valve on Control Panel.

3.0 MAINTENANCE & STORAGE

3.1 CLEANING FLUID TANKS

NOTE: For tank cleaning, wand must be attached to output hose to let fluid discharge.

After each use, complete the following:

1. Close supply air valve.
2. Open air bleed valve, let tanks de-pressurize.
3. Remove cleaning tank lid and fill with approximately one gallon (3.8 lt) of water.
4. Close cleaning tank lid and air bleed valve. Open supply air valve.
5. Open clean selector valve and wand valve.
6. Close supply air valve when tank is empty.
7. Close clean selector valve, wand valve. Open air bleed valve.
8. Hydrostatically or pneumatically test tank(s) as required due to physical damage, or as required by local law.

3.2 HOSES

Replace worn hoses as required.

3.3 AIR TANK MAINTENANCE

Periodically drain air tank by opening plug valve at bottom of air tank to remove any condensation that may have accumulated during use.

Hydrostatically or pneumatically test tank(s) as required due to physical damage, or as required by local law.

3.4 OUTPUT FILTER

1. Periodically inspect filter for cleanliness. Clean with fresh water.
2. Replace filter element when fluid flow is hindered.

3.5 STORAGE

- Ensure fluid tanks are clean. (Reference Section 3.1)
- Clean the unit exterior prior to storage.
- Depressurize entire unit.

4.0 IN-SERVICE SUPPORT

Contact Tronair for technical services and information.

5.0 GUARANTEES/LIMITATION OF LIABILITY

Tronair products are warranted to be free of manufacturing or material defects for a period of one year after shipment to the original customer. This is solely limited to the repair or replacement of defective components. This warranty does not cover the following items:

- a) Parts required for normal maintenance
- b) Parts covered by a component manufacturers warranty
- c) Replacement parts have a 90-day warranty from date of shipment

If you have a problem that may require service, contact Tronair immediately. Do not attempt to repair or disassemble a product without first contacting Tronair, any action may affect warranty coverage. When you contact Tronair be prepared to provide the following information:

- a) Product Model Number
- b) Product Serial Number
- c) Description of the problem

If warranty coverage is approved, either replacement parts will be sent or the product will have to be returned to Tronair for repairs. If the product is to be returned, a Return Material Authorization (RMA) number will be issued for reference purposes on any shipping documents. Failure to obtain a RMA in advance of returning an item will result in a service fee. A decision on the extent of warranty coverage on returned products is reserved pending inspection at Tronair. Any shipments to Tronair must be shipped freight prepaid. Freight costs on shipments to customers will be paid by Tronair on any warranty claims only. Any unauthorized modification of the Tronair products or use of the Tronair products in violation of cautions and warnings in any manual (including updates) or safety bulletins published or delivered by Tronair will immediately void any warranty, express or implied.

The obligations of Tronair expressly stated herein are in lieu of all other warranties or conditions expressed or implied. **Any unauthorized modification of the Tronair products or use of the Tronair products in violations of cautions and warnings in any manual (including updates) or safety bulletins published or delivered by Tronair will immediately void any warranty, express or implied and Tronair disclaims any and all liability for injury (WITHOUT LIMITATION and including DEATH), loss or damage arising from or relating to such misuse.**

6.0 PROVISION OF SPARES**6.1 SPARE PARTS**

Spare parts may be obtained from the manufacturer:

TRONAIR, Inc.

1740 Eber Road

Holland, Ohio 43528-9794 USA

Telephone: (419) 866-6301 or 800-426-6301

Fax: (419) 867-0634

E-mail: sales@tronair.com

Website: www.tronair.com

6.2 PARTS LIST

Reference following pages for ordering information of Replacement Parts and Kits.

Parts List

When ordering replacement parts/kits, please specify model, serial number and color of your unit.

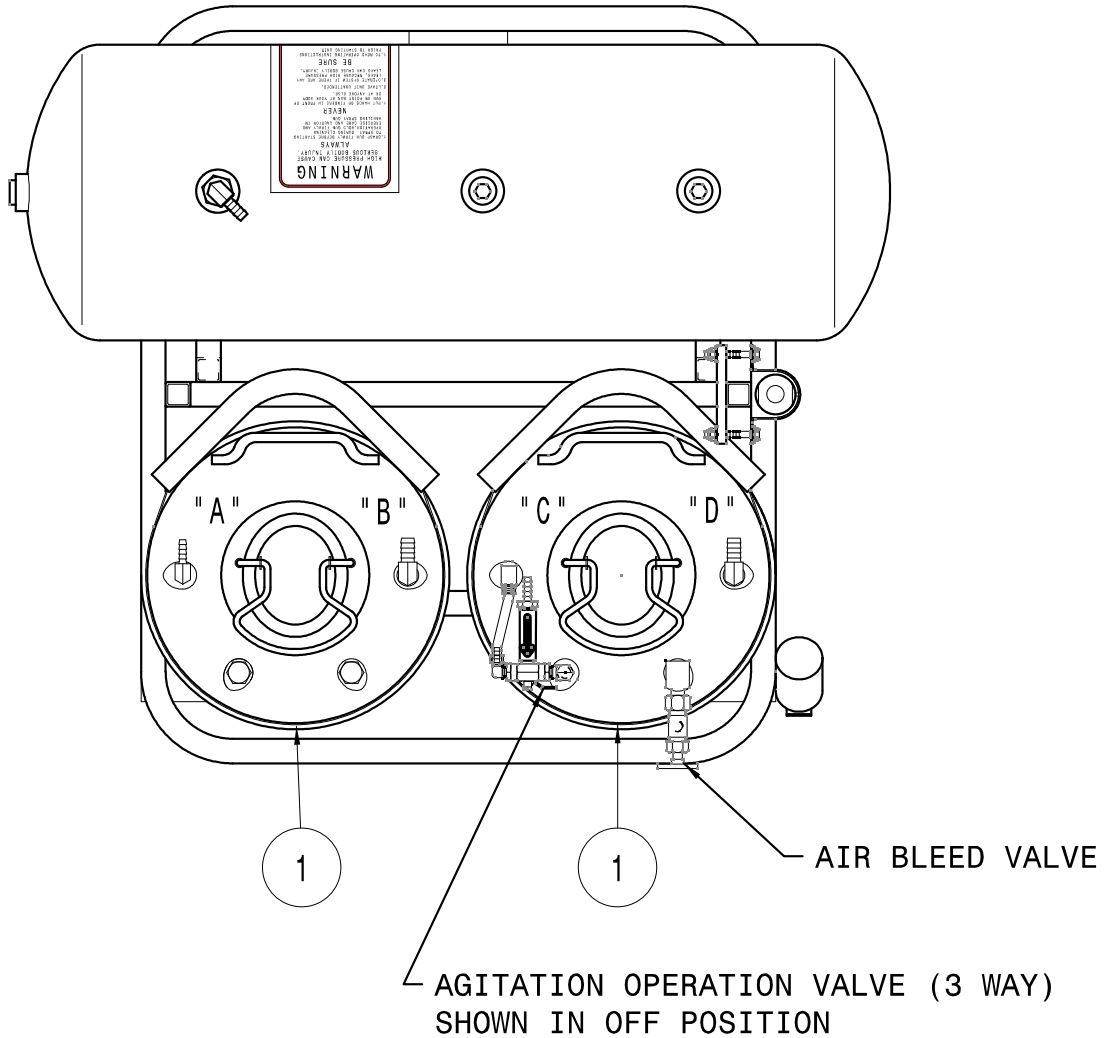

Item	Part Number	Description	Qty
1	B-404	Vessel, Pressure	2
Not Shown	HC-1400	O-Ring, Closure	2

Parts List

When ordering replacement parts/kits, please specify model, serial number and color of your unit.

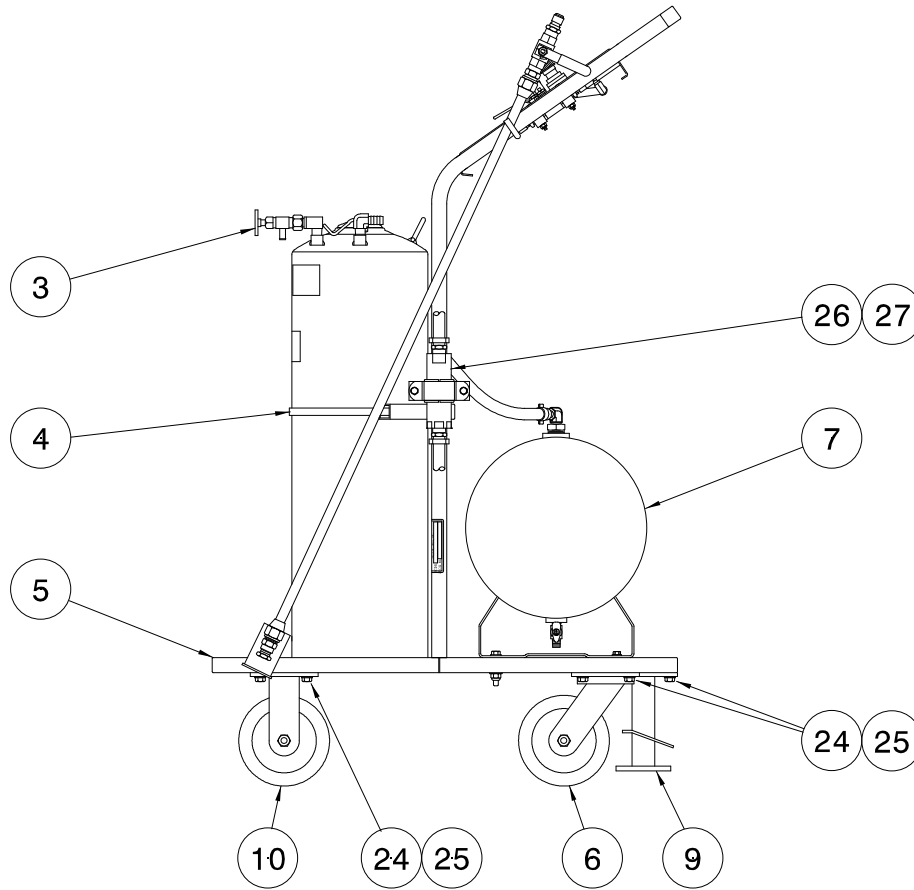

Item	Part Number	Description	Qty
3	H-1529-01	Valve, Shut-off	1
4	H-1550-12	Clamp, Snaplock	2
5	Z-5435-01	Weldment, Frame	1
6	U-1014	Caster, Swivel	2
7	PC-1080-01	Tank, Air	1
9	H-1175	Lock, Floor	1
10	U-1013	Caster, Rigid	2
24	G-1180-107004	Screw, 3/8 Hex Head, Tpg. Type F	16
25	G-1253-03	Lockwasher, External Tooth	16
26	H-2792	Filter, Output	1
27	H-2808	Element, Replacement (for H-2792)	Ref

Parts List - Control Panel Top View

When ordering replacement parts/kits, please specify model, serial number and color of your unit.

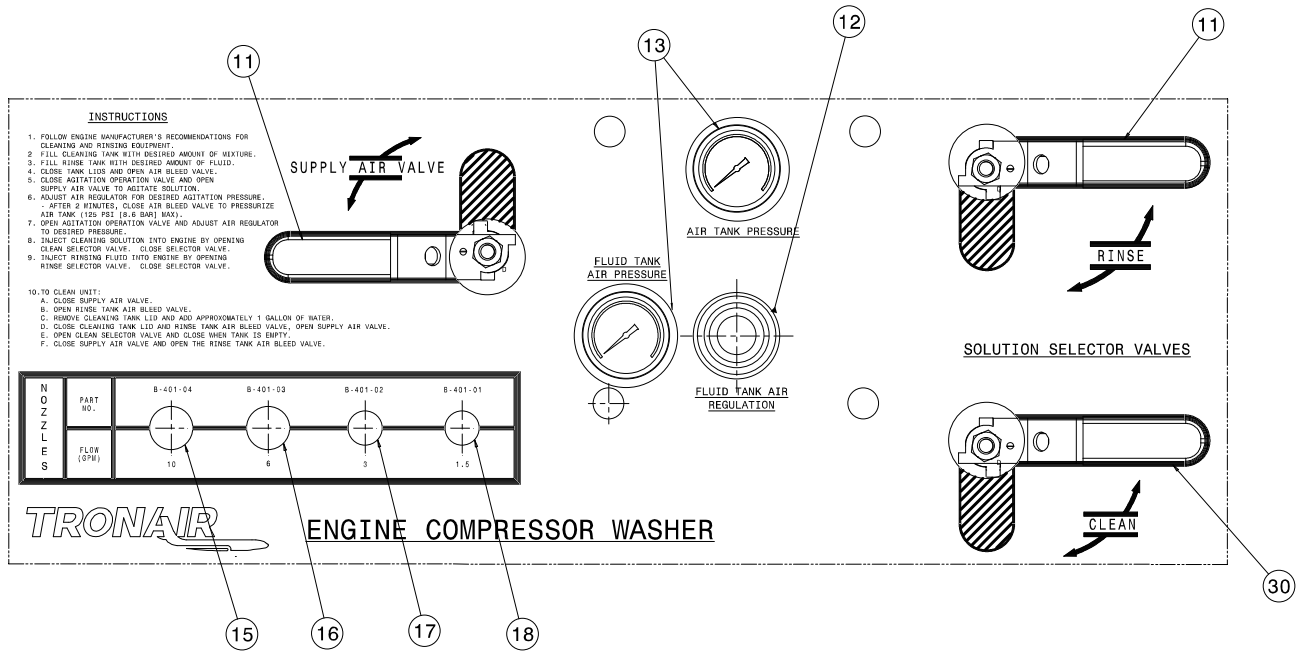

Item	Part Number	Description	Qty
11	HC-2416	Valve, Ball	2
12	H-3033	Regulator	1
13	HC-1831	Gauge, Pressure	2
15	B-401-04	3/8 Nozzle, 10 gpm	1
16	B-401-03	3/8 Nozzle, 6 gpm	1
17	B-401-02	1/4 Nozzle, 3 gpm	1
18	B-401-01	1/4 Nozzle, 1.5 gpm	1
30	HC-2350-03	Valve, Ball 1/2 NPT	1

Parts List - Control Panel Bottom View

When ordering replacement parts/kits, please specify model, serial number and color of your unit.

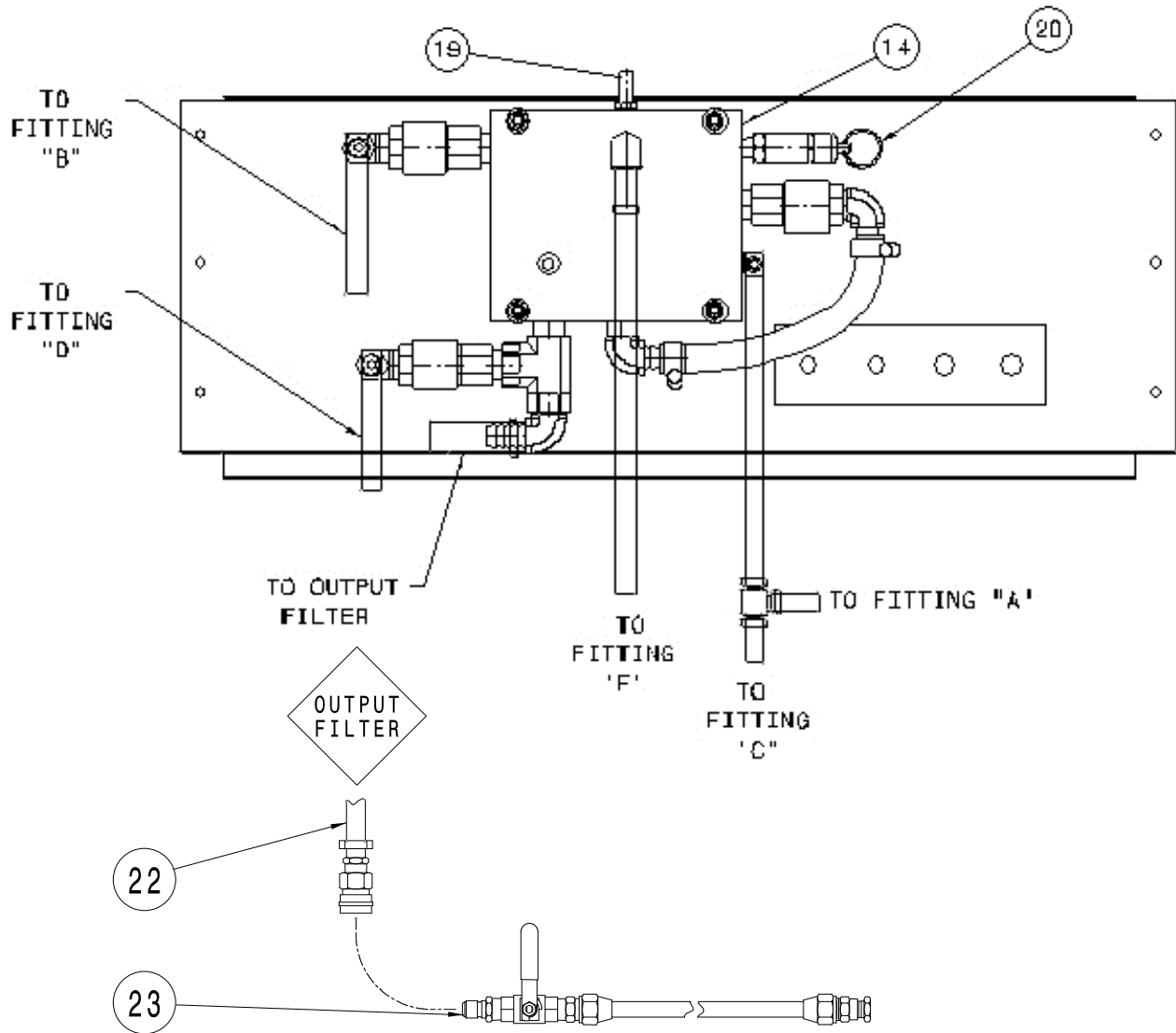

Item	Part Number	Description	Qty
14	J-4306	Manifold	1
19	H-3208	Valve Air, 1/4 NPT	1
20	PC-1017-02-125	Valve Safety, 125 psi	1
22	K-1410	Kit, Hose Assembly Replacement; consists of:	
	H-1426-02	Clamp, Hose	1
	H-1516-13	Clamp, 2 Ear Hose	1
	N-2402-041-B	Socket, Female	1
	N-2412-16	Connector, Straight Male	1
	TF-1064-08*240	Hose, 20 ft Blue	1
23	K-1411	Kit, Wand Assembly Replacement; consists of:	
	HC-1137	Valve, Ball	1
	N-2009-16-B	Connector, Male	1
	N-2010-13-B	Connector, Female	1
	N-2210-05-B	Reducer, Pipe Thread	1
	N-2403-04-B	Plug, Male Thread	1
	Z-1890	Assembly, Tube Wand	1

Optional Adapter Kits

When ordering replacement parts/kits, please specify model, serial number and color of your unit.

Part Number	Application
K-1037	DeHavilland Dash 7
K-1057	Garrett TPE331
K-1152	Pratt & Whitney PT6A
K-1243	Cessna Caravan
K-1269	Beech King Air 200
K-1357	Saab 340
K-1709	DeHavilland DHC6
K-1710	Canadair Challenger
K-1953	Allison 250 - C20J, Bell 206 - JR3
K-2248	General Electric CFM56
K-2714	deHavilland Dash 8 100, 300
K-3202	Citation X



APPENDIX - I

**Declaration
of
Conformity**



DECLARATION of CONFORMITY

The design, development and manufacture is in accordance with European Community guidelines

Engine Compressor Washer

Relevant provisions complied with by the machinery:
2006/42/EC

Relevant standards complied with by the machinery:
EN ISO 12100-1

Identification of person empowered to sign on behalf of the manufacturer:

A handwritten signature in black ink that reads "David L. Kiehl". The signature is written in a cursive style and is positioned above a horizontal line.

Quality Assurance Representative