

ADVANCE LIFTS

Installation, Operation and Maintenance Manual for the Following Equipment:

All BFL Series Lifts

This manual contains specific information for your equipment, see options on P 2-1.

In any correspondence with your distributor you will need the following information:

Model Number _____ Serial Number _____

Installation location: _____

CAUTION:

At Initial Installation, determine proper motor/pump rotation by starting the motor in very short intervals to prevent permanent pump damage. Running the pump backwards will damage it. See the Installation Instructions, Section 4, for proper procedure.

Distributor Information: _____

Advance Lifts, Inc.
701 S. Kirk Road
St. Charles, IL 60174-3428
Toll Free 1-800-843-3625
Sales Fax 1-630-584-9405
Parts and Service Fax 1-630-584-6837
E-mail: Parts@advancelifts.com

*Advance Lifts, Inc. furnishes one manual with each unit. Additional manuals are available for \$25.00 each.

SECTION 2. INDEX & INTRODUCTION

Identification Sheet	Section 1
Index & Introduction	Section 2
*Responsibilities Of Owners & Users	Section 3
*Installation Instructions	Section 4
*Operation Instructions	Section 5
*Maintenance Instructions	Section 6
* Safety Bar Placement	
Warning Label Specifications & Locations	Section 7
Hydraulic Details	Section 8
General hydraulic information	
Oil recommendation & seal compatibility	
Hydraulic schematic	
BFL Series power unit photograph	
Hydraulic component lists	
BFL Series cylinder drawings and parts lists	
Cylinder repair procedures	
Electrical Details	Section 9
General electrical information	
Electrical schematics	
Mechanical Details	Section 10
Exploded view and parts descriptions	
Spare Parts List	
Troubleshooting Hints	Section 11
Warranty	Section 12
Attachments: Material Safety Data Sheets	Section 13

***Mandatory reading before attempting installation.**

OPTIONS:

SECTION 2. (CONTINUED) INTRODUCTION

Congratulations, the equipment that you have purchased is of the highest quality available. Advance Lifts industrial scissors lifts are designed and manufactured to comply with ANSI Standard MH29.1, "Safety Requirements for Industrial Scissors Lifts". Your Advance Lift will provide you with many years of trouble free service in return for the minimal maintenance described in this manual.

Please be sure that no individual is allowed to operate the lift until they have been fully familiarized with the operating instructions in this manual. Also, insure that at least one person at the lift site is familiar with the maintenance section of this manual and is assigned responsibility for doing the maintenance on a regular basis.

Please note that the lift has a metal nameplate attached to it that contains information such as the model number, capacities, and serial number. Do not remove the nameplate. Be sure that no operator ever exceeds the capacities shown on the nameplate or they may injure personnel or cause damage to the lift.

Also, be sure to have the serial number of the lift handy if you have to call your distributor. That number identifies your specific lift and will allow your distributors personnel to give you the most thorough and timely assistance possible.

This manual is under constant review and we would appreciate any constructive suggestions that may enhance its usefulness. Please send your suggestions to Advance lifts, Inc. Attn: Customer Service Department.

Thank you for purchasing our product.

SECTION 3. RESPONSIBILITIES OF OWNERS & USERS

Inspection and Maintenance: The lift shall be inspected and maintained in proper working order in accordance with this manual and safe operating practices.

Removal from Service: Any lift not in safe operating condition shall be removed from service until it is repaired to the original manufacturer's standards.

Repairs: Authorized personnel in conformance with the manufacturer's instructions shall make all repairs.

Operators: Only trained and authorized personnel shall be permitted to operate the lift. They must understand to be alert to safety hazards during all operations.

Before Operation: Before using the lift, the operator shall have:

1. Read and understood the manufacturer's operating instructions and safety rules, or been trained by a qualified person.
2. Inspected the lift for proper operation and condition. Any suspect item shall be carefully examined and a determination made by a qualified person as to whether it constitutes a safety hazard. All unsafe items shall be corrected before further use of the lift.

During Operations: The lift shall be used only in accordance with its intended use and within the manufacturer's limitations and safety rules:

1. Do not overload the lift.
2. Insure that all safety devices are operational and in place.
3. Insure that all personnel near the operating lift understand to stand back so that no body parts can be pinched by the mechanism or platform and any items that may fall off the lift will not strike them.

Modifications Or Alterations: Modifications or alteration of Advance Lifts industrial scissors lifts shall be made only with written permission from Advance Lifts Inc. in conformance with all applicable provisions of scissors lift manufacturer's ANSI standard MH29.1 "Safety Requirements for Industrial Scissors Lifts" and shall be at least as safe as the equipment was before modification. These changes shall also satisfy recommendations of the original equipment manufacturer for the particular application of the lift.

SECTION 4. INSTALLATION INSTRUCTIONS

1. Move the lift to the usage area; insuring the mounting surface is clean and level. If slings are used, encircle the entire lift, not just the platform. If unit is being lowered into a pit, make temporary or final hose connections before lowering into the pit. See # 3.
2. Once unit has been placed at or near the final usage area, the steel shipping bands may be cut. Do not cut bands if unit needs to be repositioned for any reason.
3. Connect the hydraulic hoses to unit. NOTE: The hoses, valve block and connection points at the lift are all marked with either "A", "B" or "C". Do not cross hose connections or lift will not function.
4. Temporally bypass the system interlock by connecting the Black and White wires together from the customer interface wires see electrical schematic on page 6-3. **Danger!** Interface bypass should only be used during initial set up and never during normal operation.
5. Plug hydraulic power unit into power supply and using the "Maintenance" controls raise and lower the unit several times to begin the air bleeding process. Continued use will completely remove all air from system. No other bleeding is necessary. **Caution!** Power unit shall be located within visual range of lift so that any maintenance operations can be observed from control box.
6. Once unit is in final position, raise unit fully then deploy the safety maintenance devices. Lower unit onto devices and lock out the electrical system to disable unit movement. Follow your companies lock out and tag procedures.

Caution! Before securing the unit to the floor, shim or grout the entire base frame assembly. Continuous base frame support is essential for proper installation.

7. Level the unit using steel shims. Shim or grout any portion of the base frame that is not fully supported by the surface.
8. Lag the unit in place using 3/4" x 6-1/4", "Rawl-Studs" or wedge anchors in the holes provided, minimum embedment depth of 3.375".
9. Install upper proximity switch and pushbutton stations.
10. Lower proximity switch has been preset by the factory for optimal function. The retaining nut has been marked with a florescent substance to show the proper depth of insertion, **do not adjust!** Simply mount the proximity in place provided during installation.
11. Remove interlock bypass and install all interlocks before attempting automatic operation.
12. Clean any debris or spilled fluid as they may later be misinterpreted as mechanical trouble or a cylinder leak. Due to the rigors of shipping it may be necessary to tighten some hose fittings. Remove maintenance bars and lower the unit.
13. Instruct user(s) in the proper operation of the lift, safety precautions and equipment capacity. Supply maintenance personnel with this service manual.

INSTALLATION NOTES:

It is strongly recommended that an emergency stop button be installed at or near the up/down controls to stop movement in the event of an emergency. These switches should be tied in with the safety interlock circuit.

Some systems are designed with a timed travel function. If lift does not reach the desired upper or lower proximity switch within 60 seconds, the unit will shut down. Pressing either the up or down button will reset the timer and resume function. **Caution!** Continual timing out will damage the pump.

SECTION 5. OPERATING INSTRUCTIONS

Hydraulic scissors lifts have an excellent safety record overall, but as with all moving equipment, they can be dangerous. Operators must use common sense and take responsibility for the safety of everyone near the lift. They must use the safety devices provided and be careful not to surprise anyone in the area with the movement of the lift.

Pre-operational checks:

1. Check all electrical wiring and connections to be sure that they are completed properly and are operational.
2. Check for obstructions or debris that may interfere with the safe operations of the lift.
3. Be sure that all personnel in the area are a safe distance away from the lift and aware that you are about to operate it.
4. If there are any optional safety devices such as gate interlocks and proximity switches, check them for proper operation.

Test operate the equipment:

1. Station yourself so that you will always see the equipment when it is in operation. Never operate the equipment blind!
2. Raise the equipment and by pressing the "UP" and "DOWN" buttons with the unit in automatic mode.
3. Adjust upper proximity switch to stop platform at desired raised height.
4. Cycle the equipment several times to be sure that it is operating smoothly with no jerking or sudden movement. On initial start up there may be some air in the lines or the cylinders may be dry due to storage so it may take several cycles to smooth out the operation. If the operation is not smooth after several cycles, contact your maintenance personnel. Any evidence of binding or scraping in the operation shall cause you to immediately stop using the lift.
5. Check all safety devices for proper operation.
6. If you elect to test load the equipment be sure that you do not exceed the capacities shown on the nameplate. Overloading may cause structural stresses that may not show up for some time, but will diminish the life and capacity of the unit. If you have any questions about testing the unit, call our customer service department at 1-800-843-3625.

Daily operation:

1. All personnel shall be required to read the entire operating instruction section of this manual prior to operating the lift.
2. Operators must know the capacity of the unit and be aware of any loads that may exceed the capacity.

SECTION 5. (CONTINUED) OPERATING INSTRUCTIONS

Daily operation (continued):

3. **WARNING!** Operators must be alert to personnel in the vicinity of the lift. Avoid any surprises to these personnel in regard to movement of or the position of the lift. Never operate unit if you cannot see it and the personnel around it.
4. On the first use of the lift each day, the operator shall check to see that the lift is functioning properly and smoothly. All safety devices shall be in place and operating correctly.
5. Loads shall be centered before raising or lowering the lift as this will help insure even wear on all moving parts

SECTION 6. MAINTENANCE INSTRUCTIONS

1. Always remember that machinery with large moving parts can seriously injure you.
2. Read and understand this manual before attempting any service work.
3. **WARNING!** Always use the safety bars or safety leg when working on the unit in the elevated position or reaching under the platform. (See photo on page 6-3, at the end of this section for proper positioning and engagement of the safety bars).
4. When using the safety bars, adhere to the following rules:
 - A. The unit must be unloaded.
 - B. Be sure the safety bars are properly engaged.
 - C. Hold the down pedal or pushbutton an extra 10 seconds when lowering onto the safety bars to be sure that all the weight of the lift is on the bars.
 - D. Disconnect and tag the electricity to the unit to prevent accidental movement of the lift by other personnel.
 - E. Spend as little time as possible under the lift.
5. Only use replacement parts recommended by the manufacturer.
6. Do not let the equipment stay in disrepair; fix small problems before they become big problems. A unit in disrepair can become a severe hazard if left unattended.
7. Inspect the equipment on a regular schedule, preferably monthly.
8. Never work on the hydraulics or electrical systems unless the unit is fully lowered or properly sitting on the safety support or wheel block.
9. Never apply a load to the equipment until the baseframe is continuously supported.
10. **WARNING!** Never expect to hold the leg assemblies open by simply lifting one end of a platform.
 - A. The roller end of most lifts is not “gibbed” or captured in any way, so lifting on the roller end will simply tilt the platform.
 - B. Even if you raise the clevis end of the platform, if the base frame is not firmly lagged to the ground or held down by some other means, the legs will come up with the platform in an unpredictable manner and could cause personal injury.
 - C. The only safe way to hold a lift’s legs open is the factory designed safety support.

SECTION 6. (CONTINUED) MAINTENANCE INSTRUCTIONS

Routine Maintenance:

Weekly: Once a week or after repetitive operation, the unit shall be raised to its full height. This will get rid of cylinder oil seepage buildup and lubricate the upper cylinder barrel. This fluid will be returned to the reservoir.

Monthly:

Check the hydraulic fluid level. Caution! When checking fluid levels, make sure the unit was raised to the full-up position and then lowered onto the maintenance bars.

WARNING! Be sure the maintenance safety leg or safety bars are properly engaged before performing maintenance checks 2 through 6 or reaching beneath a raised lift. (See instructions 3, 4 and 10 above).

1. Clean all debris from the vicinity of floor and pit mounted units in order to avoid interference with the lift mechanism or rollers.
2. Check for presence and proper seating of all snap rings and clips on all axles, cylinder and rollers.
3. Check rollers, pins and bushings for any signs of wear such as flat spots, missing fasteners, or dislodged bearing material.
4. Check the hydraulic fittings for cracks or leaks and clean up any weepage on or beneath the cylinder.
5. Check hoses and electrical lines for abrasions or other abuse and check for snug connections.
6. Operate the unit and check for any abnormal noise or vibrations.
7. Check all safety devices on the unit such as the condition of the pleated bellows or smooth operation of the electric toe guards.

Seasonal or Semiannual Maintenance: Advance Lifts recommends that you change your hydraulic fluid annually. Change hydraulic fluid for ambient temperature change if appropriate or if there is any evidence of accumulated condensation creating water contamination. Oil should be changed at least once per year under normal operating conditions and more frequently in dirty environments or under heavy usage.

Testing for maximum capacity of lift. There are two methods of testing

SAFETY MAINTENANCE BAR INSTRUCTIONS

WARNING

Always use the safety bars for any service or maintenance. **Never** go or reach under the lift unless both safety bars are securely in place and the power to the unit has been disconnected from its power source to prevent others from operating the lift. **Never** use the safety bars with a load on the platform.

CAUTION! Never use the lift unless the safety bars are properly stored or damage may occur to the equipment.

Maintenance Bar Usage

1. Rotate maintenance bars until they come into contact with the baseframe. Always use both bars when doing maintenance.
2. Once both bars are in position, lower the unit onto them. Be certain the bars are positioned as shown in photo 1-2.
3. Once the unit has been lowered onto the bars, continue pressing the “Down” button to relieve all system pressure making hydraulic disassembly possible.
4. When storing the maintenance bars be certain they are rotated completely as shown in photo 1-1 or they may be damaged or interfere with the unit collapsing fully.

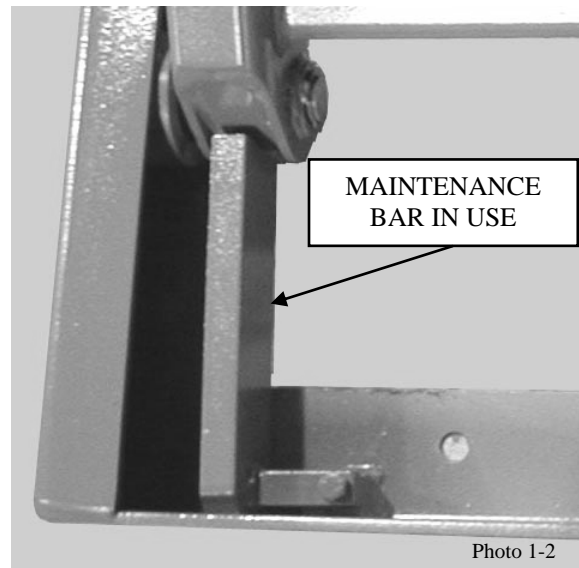
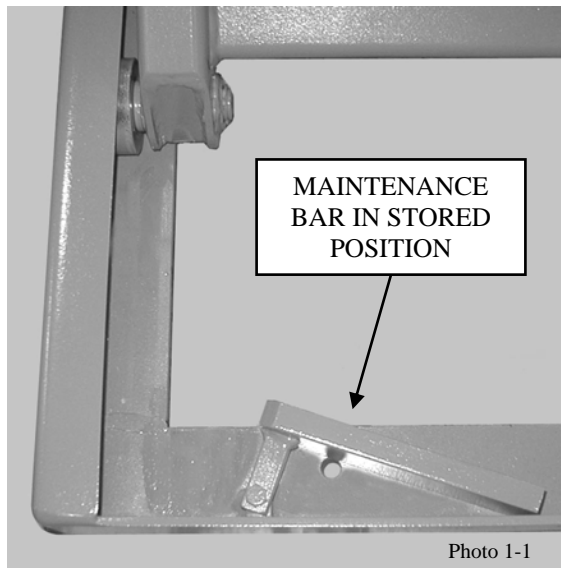

SECTION 7. WARNING LABEL SPECIFICATIONS & LOCATIONS

WARNING LABEL LOCATIONS & SPECIFICATIONS

The warning and informational labels normally attached to BFL series lifts, are shown below and their proper mounting locations are shown on page 7-2. Descriptions of the labels are as follows:

Label 1: This is simply a promotional label identifying the unit as Advance Lifts unit.



Label 2: This is the formal nameplate and it shall never be removed from the unit. The serial number on this nameplate is critical in identifying the specific unit for correct parts and service information. This plate also informs all readers of the proper capacity limits of the unit.

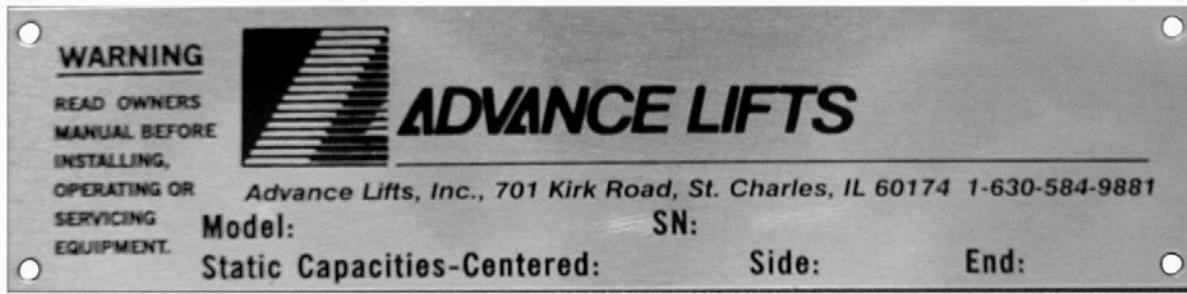

Label 3: This is an important "Danger" label that warns users of the three greatest hazards.



Label 4: This is a "Warning" label to not ride on the unit.



Label 5: This is a "Danger" label reinforcing the need to use maintenance safety legs.

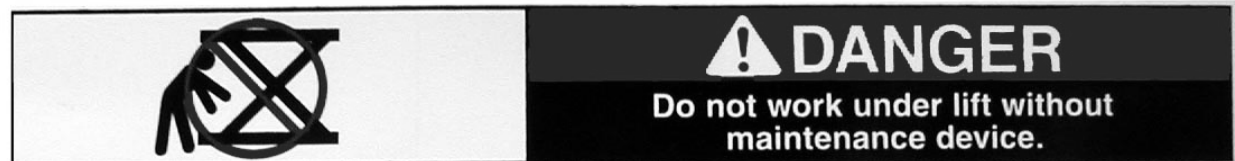

WARNING LABEL LOCATIONS

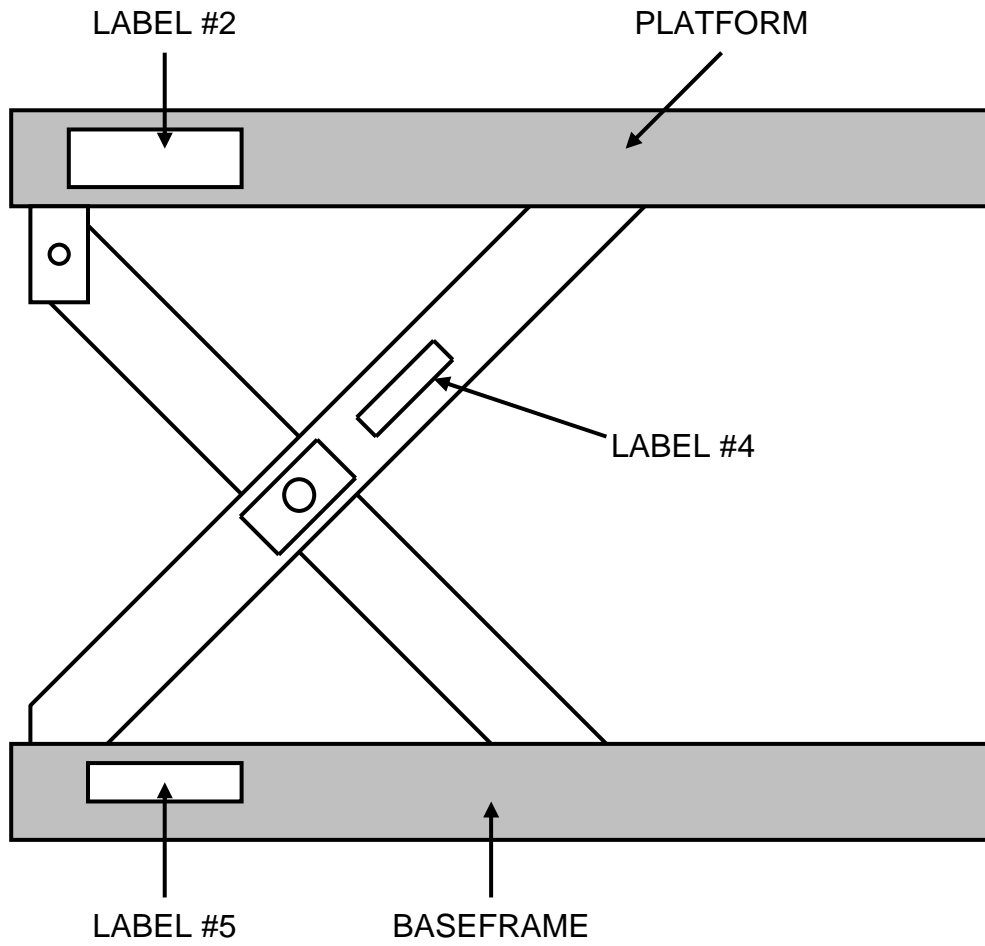
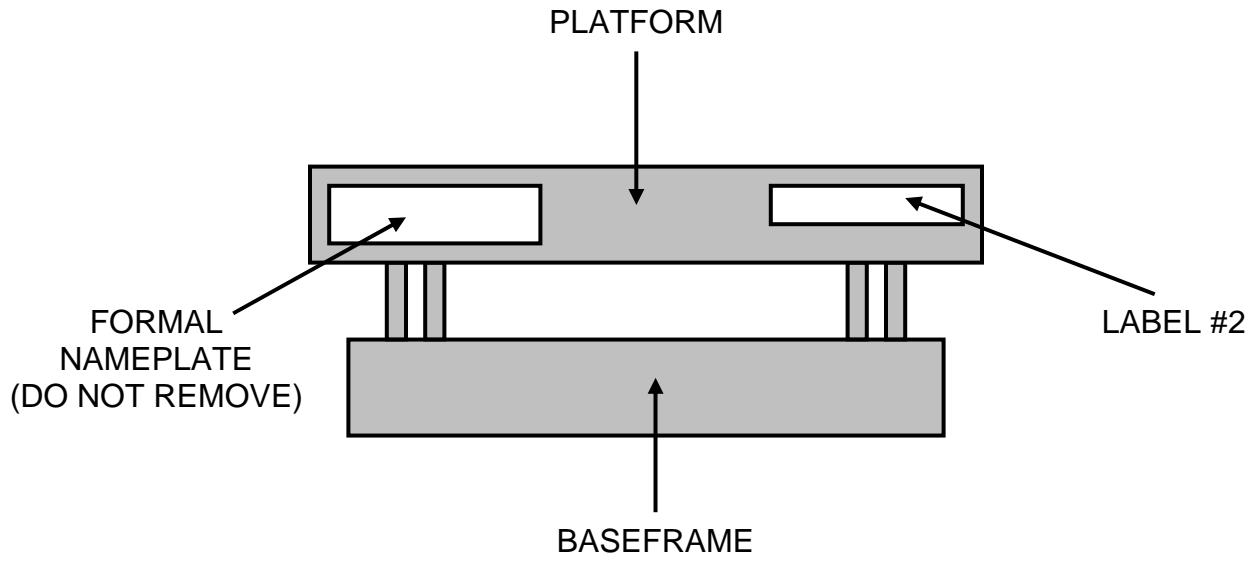

DRAWING FOR REFERENCE PURPOSES ONLY, NUMBER OF SCISSORS LEGS MAY VARY

SECTION 8. HYDRAULIC DETAILS

1. General Hydraulic Information

- A. All hydraulic cylinders will require the replacement of packings or seals after a period of time depending on usage and environmental conditions. It is considered normal maintenance. However maintenance personnel shall recognize the difference between leakage and weepage.
- B. Weepage is the normal accumulation of fluid that passes the seals in the course of operations, as the hydraulic fluid properly performs its lubrication function on cylinder walls and piston rods. It may be occasionally observed passing through the breather lines between the cylinder and the reservoir.
- C. Leakage is fluid that leaks past worn or cut packings and seals. It too may be observed coursing through the breather lines and if the seals are worn enough the fluid may push the breather line off.
- D. All BFL units have breather lines that return any weepage or leakage of fluid from the cylinder to the reservoir. It is important to make sure the lines are not full of fluid at all times. Some visible fluid is normal; a unit that will not maintain raised height could have worn or cut packings that need to be repaired. See "Repacking" under cylinder repair procedures in Section 8, page 8-8.
- E. Always be careful when working around cylinders, not to nick the extended rod or dent the cylinder casing, as this may cause damage to cylinder seals or packings.
- F. If you elect to repaint any part of the lift, cover exposed rods with plastic or soluble grease, which can be removed after painting to insure that no paint sticks to the rods and damages the packings or seals.

2. General precautions:

- A. **Caution!** Be sure that all pressure is relieved from the hydraulic system before disassembling any components. Continue to hold the "down" control for several seconds after fully lowering the unit on its safety support or the ground, before opening a hose line or hydraulic component.
- B. Always be careful to avoid contamination entering the system. Be especially careful with the ends of hoses, which may fall into oil dry, or dirt. If you suspect contamination, flush the system and components.

3. Hydraulic fittings, sealant and torque's:

- A. Advance Lifts may be equipped with either NPT fittings (tapered), or SAE fittings (with O-ring seals), or JIC fittings (37° flare). None of these fittings are interchangeable, know the difference.
- B. Be careful when tightening NPT fittings not to over-tighten and crack them. Swivel fittings are especially vulnerable and shall only be tightened enough to stop leaking.
- C. If leakage persists after tightening the fittings fairly hard, inspect fittings for burrs on the mating edges or the possibility of a 37° JIC fitting being mixed with 30° NPT fittings or either one being mixed with SAE 45° fittings.

SECTION 8. HYDRAULIC DETAILS (CONTINUED)

- D. When using Teflon tape on NPT fittings, be sure the tape is started 1-1/2 threads back from the leading edge and only use 2 wraps to be sure that tape does not break off and contaminate the system. You may substitute pipe sealant with Teflon paste from "Pro Lock" or "Loctite", but again don't over apply. Never use sealant or tapes on JIC, O-Ring Boss or swivel fittings.
- E. Be extremely careful not to over-tighten ORB fittings, thread the fitting finger tight and then tighten the nut on the fitting.
- F. Never reuse old Teflon tape. Once a connection has been opened, remove all tape and apply fresh tape.

OIL RECOMMENDATIONS AND SEAL COMPATIBILITY

Fluids:

1. The current standard hydraulic fluid is a multi viscosity ISO-46 group II base oil hydraulic fluid. This is the fluid normally supplied by the factory and is suitable for a temperature range of -10 to +100 degrees Fahrenheit. When replacing or adding fluid to an Advance Lift, use only ISO 46 hydraulic fluid that is manufactured with a group II base oil.
2. Unless approved by the Advance lifts engineering department do not use any other fluid. Brake fluids and other hydraulic fluids may damage the system's seals or hoses. If it is required to switch from one fluid to another, drain the reservoir and system completely, and then refill with the new fluid.
3. Biodegradable and fire retardant fluids are available. Contact the factory for specifications. It may be necessary to change some seals and/or hoses for total system compatibility, depending upon the specific model lift and the requested fluid.

Options:

For extremely warm temperature ranges of 120° to 140° degrees Fahrenheit, you may switch to 10W30 motor oil. If ambient temperatures are expected above 140° degrees, consult the factory.

For extremely cold temperature ranges, Advance Lifts recommends the use of a fluid heater, contact your distributor for more information and specifications.

Seals:

Generally, the seals in the unit are Buna-N-Nitrile and polyurethane. The hoses are either PVC for suction lines or braided wire for pressure lines. Always call the factory about special fluids rather than make assumptions on your own.

HYDRAULIC SCHEMATIC

(INSERT HYDRAULIC SCHEMATIC HERE)

BFL SERIES CYLINDER

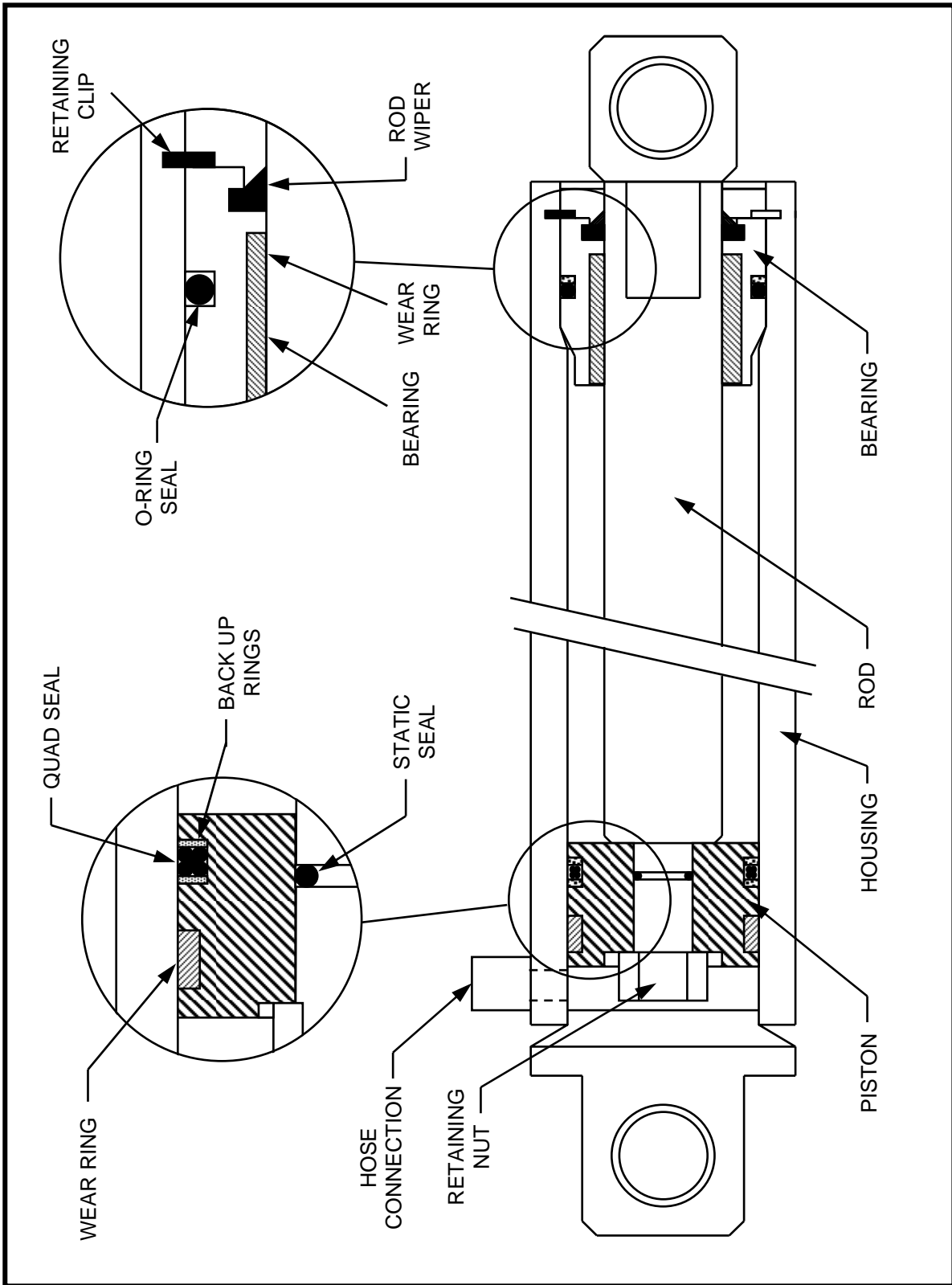

REPAIR PROCEDURES FOR BFL-SERIES CYLINDERS

Tools & Supplied required:

“Lubriplate” and hydraulic fluid matching the existing fluid in the system for topping off the reservoir when finished. (**Current standard fluid is an ISO 46 hydraulic fluid**)

A five- (5) gallon bucket to collect fluid from the cylinders.

Wrenches to disconnect hydraulic fittings.

Small screwdriver

Emery cloth.

Properly sized ball hone

Clean lint free cloths and hose caps.

Clean work surface (butcher paper on top of most surfaces works well), with a means of holding the cylinder in a fixed position for disassembly and re-assembly.

Safety legs supplied with each Advance unit.

Cylinder Removal, BFL-Series units:

1. Raise the empty lift and settle it securely on its safety bars or leg. See page P 6-3 for proper lift blocking.
2. Once settled securely, depress the down control an additional 20 seconds to relieve any pressure from the hydraulic system. Remove the power connection to the power unit and mark with a warning label or lock the connection out to prevent unintended reconnection. (Check your company lockout and tag Standard Operating Procedures.)
3. Disconnect the hydraulic hose from the cylinder and cap the hose to prevent contamination.
4. Remove the cylinder from the lift by first removing the retaining clips from the upper cylinder pin. Free the upper pin and swing the cylinder into an easily supported position, then remove the retaining clips and pins from the bottom of the cylinder.
5. Place the hose connection end of the cylinder in a 5-gallon bucket and force the cylinder closed to drain the hydraulic fluid from the cylinder. Do not reuse the fluid unless you are sure it is contamination free by careful straining.

BFL-Series Cylinder Disassembly:

1. Secure the cylinder with a rod through the lower retaining pin hole. Do not use a vise, which will crush or otherwise damage the housing.
2. Use a small screwdriver to remove the spiral-retaining ring in front of the cylinder bearing.
3. Pull the cylinder rod out of the housing until the piston meets the bearing block, then push the rod back into the housing a few inches. With a quick pulling motion, gently tap the bearing out of the housing using the piston to tap out the bearing.
4. Pull out the rod, bearing and piston assembly. The retaining ring groove in the housing will cut the piston seal upon removal, clean the groove thoroughly before assembly.
5. Remove the hex nut adjacent to the piston, then slide the piston and bearing off the rod. The hex nut can be very tight, if difficulty is encountered in removal; a small amount of heat can be applied to help break the nut loose. Clean all the parts and place them on a clean surface to avoid contamination.

REPAIR PROCEDURES FOR BFL-SERIES CYLINDERS (continued)

BFL Series Re-packing and Inspection:

1. Carefully inspect the entire housing with a flashlight for any evidence of rust, scratches or surface blemishes. Small blemishes may be removed with fine emery cloth but larger faults will require the use of a hone. Be sure thoroughly clean the housing when you are done to avoid contamination.
2. Do not become the victim of a false economy by using only part of a re-packing kit. Since you have invested the time in disassembling the cylinder, use all new packing parts and seals.
3. Remove the rod wiper on the bearing by using a screwdriver to bend the seal inward to collapse and remove it. Inspect the groove.
4. Lubricate and insert a new wiper with your fingers, sliding it into its groove. Depending upon temperature, the rod wiper may slide in much easier if it is warmed in hot water, then dried, lubricated, and inserted. The bearing may now be slid back onto the rod.
5. Begin re-packing the piston by using a screwdriver to carefully remove the old backup rings and seal from the groove. The cylinder is also equipped with a wear ring that shall be removed at this time. Be careful to leave the grooves nick free and clean.
6. Place the static O-ring seal into the clean and dry groove on the cylinder rod. Lubricate the seal surfaces and the I.D. of the piston bore. Slide the piston back into position noting that the flat side, not the chamfered side, shall rest against the retaining nut. Reinstall the retaining ring or nut using Loctite if the fastener is a plain nut; torque the nut to 600ft. /lbs.
7. Clean the grooves on the piston. Place the packing kits and wear ring in place into the clean and dry grooves. Lubricate the OD of the piston seals, wear ring and the housing snap ring grooves, then slide the entire assembly into the housing.
8. Re-assemble the bearing block in the reverse manner that it was disassembled. In all cases, be sure the retaining rings(s) are fully seated into their grooves or the cylinders will come apart when fully extended, causing an accident.

SECTION 9. ELECTRICAL DETAILS

General Electrical Information (BFL-Series Units):

The motor supplied as standard on BFL-Series units is a 208/230/460v 3-phase motor, with connection diagrams on the outside of the motor for low voltage (230V) or high voltage (460V). This motor is also rated for 208V. As any standard motor is rated for $\pm 10\%$ of voltage variation, this motor will operate properly, within ratings, at 208, 220, 230, 240, 440, 460, and 480V, 3-phase supply.

If motor is intended for 208V line usage, some caution is advised, if your motor is a 230 volt motor, and your 208V line voltage drops to 207 volts, (a drop of only $\frac{1}{2}\%$), the motor will be operating at -10% in a marginal region. Wiring runs and actual voltage become very important. If you line voltage will be varying (due to loads elsewhere in the system, etc.) you may have an advantage by ordering as an option a 208V $\pm 10\%$ motor.

To reverse the direction of rotation of a 3-phase motor, reverse any two of the three power leads to the motor. On single-phase motors, see wiring diagram on motor.

Field Changes in Voltage, 3-Phase (230V to 460V):

- A. Change transformer primary connections to 460V.
- B. Change overload protection to proper value as per currents in motor tables. Order new overload; adjust new overload to motor full load current setting. Insure the overload is set to "manual" reset, not "automatic" to insure the equipment cannot re-start automatically.
- C. Change motor connections for high (460V).
- D. Change plug and receptacle for power, if required.

Field Changes in Voltage, 3-Phase (460V to 230V):

- A. Change transformer primary connections to 230V.
- B. Change overload protection to proper value as per currents in motor table. Order new overload; adjust new overload to motor full load current setting. Insure the overload is set to "manual" reset, not "automatic" to insure the equipment cannot re-start automatically.
- C. Change motor connections for low (230V).
- D. Change plug and receptacle for power, if required.

IMPORTANT: When making voltage changes, ensure motor rotation is correct.

ELECTRICAL NOTES:

The electrical control box contains a "Down Speed" potentiometer that has been preset by the factory. The knob has been sealed with an engineering sealer and should not be adjusted. **Caution!** Adjusting the potentiometer will cause erratic function and could damage the hydraulic or mechanical systems.

ELECTRICAL SCHEMATIC

(INSERT ELECTRICAL SCHEMATIC HERE)

SECTION 10. BASIC PART IDENTIFICATION

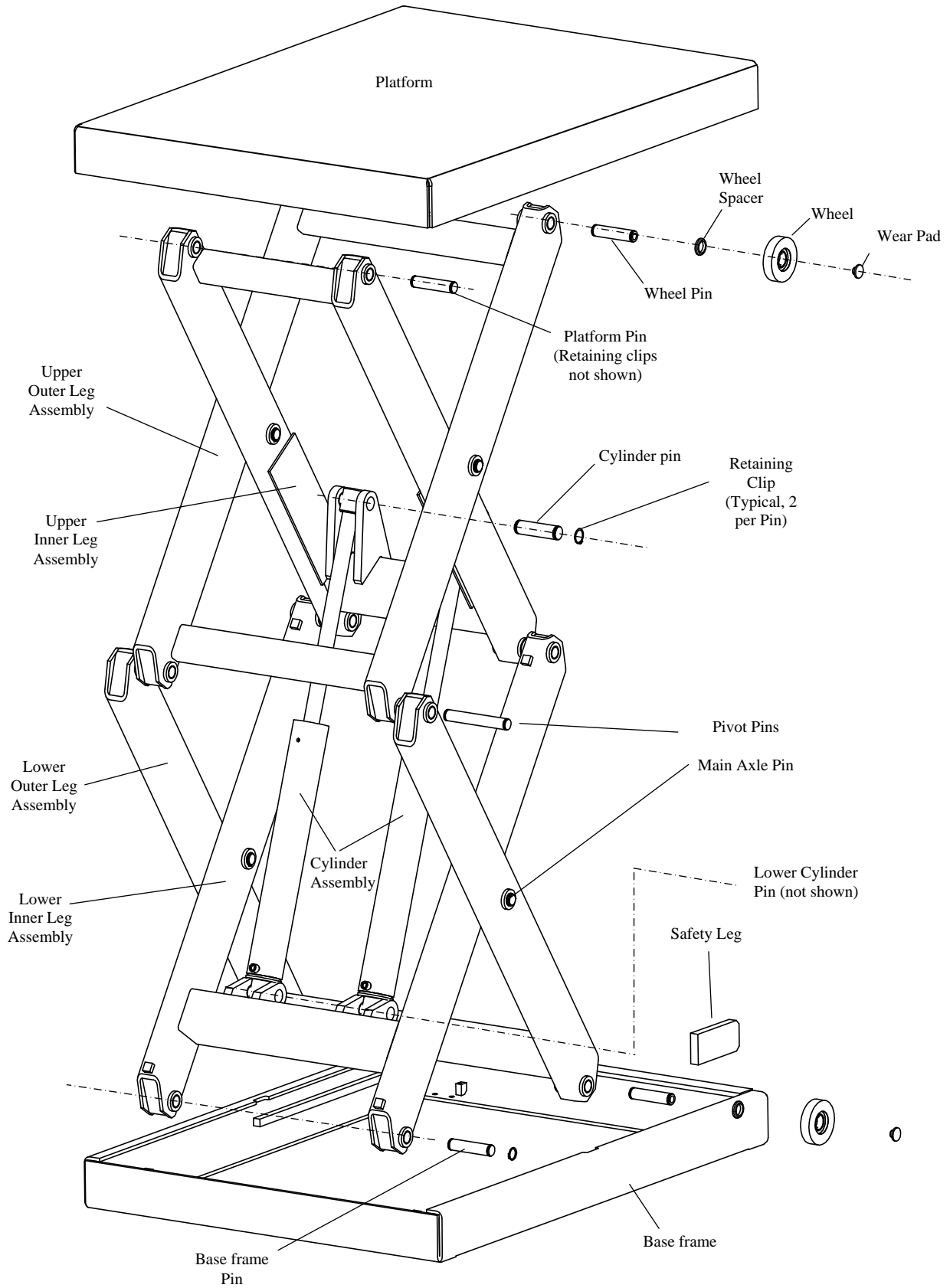

SECTION 11. TROUBLESHOOTING HINTS

Warning! Only qualified service personnel shall undertake service work on hydraulic lifts. The service person shall be able to read and understand wiring and hydraulic diagrams, know how to safely troubleshoot live electrical circuits and be familiar with this manual and all safety devices on the lift. Contact your distributor if you need assistance in troubleshooting your equipment.

Warning! No work shall be performed beneath a raised lift platform unless the safety leg is installed in accordance with Section 6 of this manual

Symptom	Probable Cause	Corrective Action
Equipment does not raise, motor is running	Load is too heavy	Reduce weight to rated load
	Motor rotation is reversed	On three phase units, have an electrician reverse any two power leads on the power plug to reverse rotation. (Note: that the hydraulic pump can not be run backwards for more than a few seconds without suffering severe damage).
	Motor may be single-phasing	Check wiring and overloads to determine that all three phase lines are present at the motor.
	Low voltage at motor terminals	Check voltage at motor terminals while unit is under full load. If current is below requirements in Section 9 of this manual, correct the wire size or run length.
	Pinched hydraulic line	Check to see that no lines are pinched. Correct as necessary.
	Low oil level in reservoir	Check oil level and correct as necessary. If oil is low, check for leaks also.
	Units with external Power units	Check breather cap on reservoir
	Clogged suction line	Observe the clear suction line to be sure that it remains full of oil with no air bubbles at anytime. If there are any bubbles, check for a loose fitting, cracked ports or a clogged suction filter.

SECTION 11. TROUBLESHOOTING HINTS (CONTINUED)

Symptom	Probable Cause	Corrective Action
<p>Equipment does not raise (continued)</p>	<p>Down solenoid wired Incorrectly to energize with up circuit</p>	<p>Hold screwdriver on down solenoid and press “up” switch. If you feel magnetism correct the lift wiring.</p>
	<p>Down solenoid stuck open</p>	<p>Remove the down solenoid and check for free movement of the plunger.</p>
	<p>Pump failure</p>	<p>Place gauge on pump and if it does not produce 3200 psi., replace pump.</p>
<p>Equipment raises too slowly</p>	<p>Load is too heavy</p>	<p>Reduce weight to rated</p>
	<p>Pinched hydraulic line</p>	<p>Check to see that no lines are pinched. Correct as necessary.</p>
	<p>Dirt in down solenoid</p>	<p>Clean the down so that it may fully close.</p>
	<p>Wrong oil for ambient temperature</p>	<p>See oil recommendations in Section 8 of the manual.</p>
	<p>Dirt in reservoir breather</p>	<p>Clean air breather.</p>
	<p>Low voltage at motor</p>	<p>Check voltage at motor terminals while unit is under full load. If current is below requirements in section 9 of this manual, correct the wire size or run length.</p>

SECTION 11. TROUBLESHOOTING HINTS (CONTINUED)

Symptom	Probable Cause	Corrective Action
Equipment raises too slowly (continued)	Clogged suction line.	Observe the clear suction line to be sure it remains full of oil with no air bubbles at anytime. If there are any bubbles, check for loose fittings, cracked ports or clogged suction filter.
Motor heats or labors excessively.	<p>Low voltage at motor terminals.</p> <p>Wrong oil for ambient temperature.</p> <p>Load is too heavy.</p>	<p>Check voltage at motor terminals while unit is under full load. If current is below requirements in Section 9 of this manual, correct the wire size or run length.,</p> <p>See oil recommendations in Section 8 of manual.</p> <p>Reduce load to rated load.</p>
Operation is spongy.	Air in cylinders.	Bleed the cylinders to remove air trapped in them. If this reoccurs, check for air bubbles in the suction line and air leaks.
Equipment lowers too slowly.	<p>Pinched hydraulic line.</p> <p>Dirt in flow control valve.</p>	<p>Check to see that no lines are pinches. correct if necessary.</p> <p>Remove and clean flow control valve.</p>
Equipment lowers too fast.	<p>Dirt in check valve.</p> <p>Dirt in flow control valve.</p>	<p>Remove and clean check valve.</p> <p>Remove and clean flow control valve.</p>

SECTION 11. TROUBLESHOOTING HINTS (CONTINUED)

Symptom	Probable Cause	Corrective Action
Lift raises, then Lowers.	<p>Dirt in check valve.</p> <p>Down solenoid wired Incorrectly.</p> <p>Leaking cylinder packings.</p>	<p>Remove and clean check valve.</p> <p>Hold screwdriver on down solenoid and if you feel magnetism correct the lift wiring.</p> <p>Repack cylinders.</p>
Lift raises, but will not lower.	<p>Faulty solenoid valve</p> <p>Down solenoid incorrectly wired.</p> <p>Faulty solenoid coil.</p> <p>Obstruction in baseframe.</p>	<p>Replace valve.</p> <p>Rewire per diagram in Section 9 of this manual.</p> <p>Replace coil.</p> <p>Raise lift to clear obstruction then remove.</p>
Oil spraying out of reservoir.	<p>Clogged air breather.</p>	<p>A dirty breather filter may build up positive pressure which will spray oil. Clean air breather.</p>
Lift will not raise and motor will not run.	<p>Control voltage fuse blown.</p> <p>Motor starter overload</p> <p>Wrong voltage to unit.</p> <p>Transformer connections loose.</p> <p>Transformer defective.</p> <p>Pushbutton defective</p> <p>DC units:</p>	<p>Replace fuse.</p> <p>Reset motor starter.</p> <p>Check wiring to confirm wiring is compatible with available power.</p> <p>Check and tighten terminal screws on transformer.</p> <p>Replace transformer.</p> <p>Replace pushbutton</p> <p>See Battery charging instructions.</p>

ADVANCE LIFTS INC. WARRANTY

For a period of one year from date of shipment from the Company's plant, the Company agrees to replace or repair, free of charge, any defective parts, material or workmanship on new equipment. This shall include electrical and hydraulic components.

For a period of ten years from date of shipment from Company's plant, the Company agrees to replace or repair any defective structure.

Company authorization must be obtained prior to the commencement of any work. The Company reserves the right of choice between effecting repairs in the field or paying all freight charges and effecting the repairs at the Company's plant. The Company further reserves the right of final determination in all warranty considerations. Evidence of overloading, abuse, or field modification of units without Company approval shall void this warranty. No contingent liabilities will be accepted.

Damage incurred in transport is the responsibility of the carrier and is not covered by this warranty. Any damage detected upon receipt of equipment should be immediately reported to the carrier. If you need assistance filing your claim, please contact Advance Lifts.



1. Chemical product and company identification

Product name	CASTROL DUAL RANGE HV 46 HYDRAULIC FLUID
MSDS #	460278
Historic MSDS #:	None.
Code	460278
Product use	Hydraulic fluid For specific application advice see appropriate Technical Data Sheet or consult our company representative.
Supplier	BP Lubricants USA Inc. 9300 Pulaski Highway Baltimore, Maryland 21220-2495
EMERGENCY HEALTH INFORMATION:	1 (800) 447-8735 Outside the US: +1 703-527-3887 (CHEMTREC)
EMERGENCY SPILL INFORMATION:	1 (800) 424-9300 CHEMTREC (USA)
OTHER PRODUCT INFORMATION	1 (866) 4 BP - MSDS (866-427-6737 Toll Free - North America) email: bpcares@bp.com

2. Composition/information on ingredients

Ingredient name	CAS #	% by weight
Distillates (petroleum), hydrotreated, heavy paraffinic (Highly refined mineral oil)	64742-54-7	85 - 90
Lubricating oils (petroleum), C20-50, hydrotreated neutral oil-based, high viscosity (Highly refined mineral oil)	72623-85-9	5 - 15
White mineral oil, petroleum (Highly refined mineral oil)	8042-47-5	1 - 5
Proprietary performance additives.	proprietary	5 - 10

3. Hazards identification

Physical state	Liquid.
Color	Purple.
Emergency overview	CAUTION! MAY CAUSE EYE IRRITATION. MAY CAUSE SKIN IRRITATION. Avoid contact with eyes, skin and clothing. Wash thoroughly after handling. Prolonged or repeated contact can defat the skin and lead to irritation and/or dermatitis.
Routes of entry	Skin contact. Eye contact. Inhalation. Ingestion.
Potential health effects	
Eyes	May cause eye irritation.
Skin	Prolonged or repeated contact can defat the skin and lead to irritation and/or dermatitis. High pressure skin injections are serious medical emergencies. Injury will not appear serious at first; within a few hours, tissue will become swollen, discolored and extremely painful.
Inhalation	Mist : May cause respiratory tract irritation.

Product name CASTROL DUAL RANGE HV 46 HYDRAULIC FLUID	MSDS # 460278	Page: 1/6
Version 1	Date of issue 07/07/2005.	Format US-FULL
		Language ENGLISH.
	Build 4.2.4	(ENGLISH)

Ingestion	Causes gastrointestinal irritation and diarrhea.
Medical conditions aggravated by over-exposure	None identified.
See toxicological information (section 11)	

4. First aid measures

Eye contact	In case of contact, immediately flush eyes with plenty of water for at least 15 minutes. Get medical attention.
Skin contact	Immediately wash exposed skin with soap and water. Remove contaminated clothing and shoes. Wash clothing before reuse. Thoroughly clean shoes before reuse. Get medical attention if irritation develops. Accidental high pressure injection through the skin requires immediate medical attention.
Inhalation	If inhaled, remove to fresh air. Get medical attention if symptoms appear.
Ingestion	Do NOT induce vomiting unless directed to do so by medical personnel. Never give anything by mouth to an unconscious person. If large quantities of this material are swallowed, call a physician immediately.

5. Fire-fighting measures

Flammability of the product	May be combustible at high temperature.
Flash point	232 °C (Open cup) Cleveland.
Products of combustion	These products are carbon oxides (CO, CO ₂).
Unusual fire/explosion hazards	This material is not explosive as defined by established regulatory criteria.
Fire-fighting media and instructions	In case of fire, use water fog, foam, dry chemicals, or carbon dioxide. Do not use water jet.
Protective clothing (fire)	Fire-fighters should wear positive pressure self-contained breathing apparatus (SCBA) and full turnout gear.

6. Accidental release measures

Personal precautions	Immediately contact emergency personnel. Keep unnecessary personnel away. Use suitable protective equipment (See Section: "Exposure controls/personal protection"). Follow all fire fighting procedures (See Section: "Fire-fighting measures").
Environmental precautions and clean-up methods	If emergency personnel are unavailable, contain spilled material. For small spills add absorbent (soil may be used in the absence of other suitable materials) scoop up material and place in a sealed, liquid-proof container for disposal. For large spills dike spilled material or otherwise contain material to ensure runoff does not reach a waterway. Place spilled material in an appropriate container for disposal. Avoid contact of spilled material with soil and prevent runoff entering surface waterways. See Section 13 for Waste Disposal Information.
Personal protection in case of a large spill	Splash goggles. Full suit. Boots. Gloves. Suggested protective clothing might not be sufficient; consult a specialist BEFORE handling this product.

7. Handling and storage

Handling	Avoid contact with eyes. Avoid contact with skin and clothing. Wash thoroughly after handling.
Storage	Keep container tightly closed. Keep container in a cool, well-ventilated area. Empty containers may contain harmful, flammable/combustible or explosive residue or vapors. Do not cut, grind, drill, weld, reuse or dispose of containers unless adequate precautions are taken against these hazards.

Product name	CASTROL DUAL RANGE HV 46 HYDRAULIC FLUID	MSDS #	460278	Page: 2/6
Version	1	Date of issue	07/07/2005.	Format
				US-FULL
				Language
				ENGLISH.
				(ENGLISH)
				Build
				4.2.4

8. Exposure controls/personal protection

Occupational exposure limits

Ingredient name	Occupational exposure limits
Distillates (petroleum), hydrotreated, heavy paraffinic (Highly refined mineral oil)	ACGIH (United States). STEL: 10 mg/m ³ 15 minute(s). Form: Oil mist, mineral TWA: 5 mg/m ³ 8 hour(s). Form: Oil mist, mineral OSHA (United States). TWA: 5 mg/m ³ 8 hour(s). Form: Oil mist, mineral
Lubricating oils (petroleum), C20-50, hydrotreated neutral oil-based, high viscosity (Highly refined mineral oil)	ACGIH (United States). STEL: 10 mg/m ³ 15 minute(s). Form: Oil mist, mineral TWA: 5 mg/m ³ 8 hour(s). Form: Oil mist, mineral OSHA (United States). TWA: 5 mg/m ³ 8 hour(s). Form: Oil mist, mineral
White mineral oil, petroleum (Highly refined mineral oil)	ACGIH (United States). STEL: 10 mg/m ³ 15 minute(s). Form: Oil mist, mineral TWA: 5 mg/m ³ 8 hour(s). Form: Oil mist, mineral OSHA (United States). TWA: 5 mg/m ³ 8 hour(s). Form: Oil mist, mineral
Proprietary performance additives.	None assigned.

Control Measures Provide exhaust ventilation or other engineering controls to keep the airborne concentrations of vapors below their respective occupational exposure limits.

Hygiene measures Wash hands after handling compounds and before eating, smoking, using lavatory, and at the end of day. Appropriate techniques should be used to remove potentially contaminated clothing. Wash contaminated clothing before reusing. Ensure that eyewash stations and safety showers are close to the work-station location.

Personal protection

Eyes	Avoid contact with eyes. Chemical splash goggles.
Skin and body	Avoid prolonged or repeated contact with skin. Wear protective clothing if prolonged or repeated contact is likely.
Respiratory	None required; however, use of adequate ventilation is good industrial practice. If heated and ventilation is inadequate, use a NIOSH certified respirator with an organic vapor cartridge and P95 particulate filter.
Hands	Wear protective gloves if prolonged or repeated contact is likely. Consult your supervisor or S.O.P. for special handling directions

Consult local authorities for acceptable exposure limits.

9. Physical and chemical properties

Physical state	Liquid.
Color	Purple.
Pour Point	-45 °C
Specific gravity	0.8697
Solubility	Insoluble in cold water.
Viscosity	Kinematic: 46.5 mm ² /s (46.5 cSt) at 40°C Kinematic: 7.9 mm ² /s (7.9 cSt) at 100°C SUS: 216 SUS at 37.7°C
Viscosity Index	141

Product name CASTROL DUAL RANGE HV 46 HYDRAULIC FLUID

MSDS # 460278

Page: 3/6

Version 1 Date of issue 07/07/2005.

Format US-FULL

Language ENGLISH.

Build 4.2.4

(ENGLISH)

10. Stability and reactivity

Stability and reactivity	The product is stable.
Conditions to avoid	Keep away from heat, sparks and flame. Keep away from sources of ignition.
Incompatibility with various substances	Reactive with oxidizing agents.
Hazardous decomposition products	Products of combustion: carbon oxides (CO, CO ₂).
Hazardous polymerization	Will not occur.

11. Toxicological information

Acute toxicity	Toxicity testing not conducted. At normal ambient temperatures this product will be unlikely to present an inhalation hazard because of its low volatility. May be harmful by inhalation if exposure to vapor, mists or fumes resulting from thermal decomposition products occurs. Unlikely to cause harm if accidentally swallowed in small doses, though larger quantities may cause nausea and diarrhea.
Chronic toxicity	
Carcinogenic effects	No component of this product at levels greater than 0.1% is identified as a carcinogen by ACGIH or the International Agency for Research on Cancer (IARC). No component of this product present at levels greater than 0.1% is identified as a carcinogen by the U.S. National Toxicology Program (NTP) or the U.S. Occupational Safety and Health Act (OSHA).
Mutagenic effects	No component of this product at levels greater than 0.1% is classified by established regulatory criteria as a mutagen.
Reproductive effects	No component of this product at levels greater than 0.1% is classified by established regulatory criteria as a reproductive toxin.
Teratogenic effects	No component of this product at levels greater than 0.1% is classified by established regulatory criteria as teratogenic or embryotoxic.

12. Ecological information

Ecotoxicity	No testing has been performed by the manufacturer.
--------------------	--

13. Disposal considerations

Waste information	Avoid contact of spilled material and runoff with soil and surface waterways. Consult an environmental professional to determine if local, regional or national regulations would classify spilled or contaminated materials as hazardous waste. Use only approved transporters, recyclers, treatment, storage or disposal facilities.
--------------------------	--

Consult your local or regional authorities.

14. Transport information

Not classified as hazardous for transport (DOT, TDG, IMO/IMDG, IATA/ICAO)

Product name CASTROL DUAL RANGE HV 46 HYDRAULIC FLUID	MSDS # 460278	Page: 4/6
Version 1	Date of issue 07/07/2005.	Format US-FULL
	Build 4.2.4	Language ENGLISH. (ENGLISH)

15. Regulatory information

U.S. Federal regulations

US INVENTORY (TSCA): In compliance.

TSCA 12(b) one-time export notification:: naphthalene; naphthalene; mequinol

This product is not regulated under Section 302 of SARA and 40 CFR Part 355.

SARA 311/312 MSDS distribution - chemical inventory - hazard identification: CASTROL DUAL RANGE HV 46 HYDRAULIC FLUID: Immediate (Acute) Health Hazard

SARA 313

Form R - Reporting requirements

This product does not contain any hazardous ingredients at or above regulated thresholds.

Supplier notification

This product does not contain any hazardous ingredients at or above regulated thresholds.

CERCLA Sections 102a/103 Hazardous Substances (40 CFR Part 302.4):: naphthalene: 100 lbs. (45.36 kg); Cumene: 5000 lbs. (2268 kg); Benzene: 10 lbs. (4.536 kg); Toluene: 1000 lbs. (453.6 kg); Xylene: 100 lbs. (45.36 kg); naphthalene: 100 lbs. (45.36 kg); phosphorodithioc acid, O,O - di-C1-14- alkyl esters zinc salts ; phenol: 1000 lbs. (453.6 kg); Ethyl acrylate: 1000 lbs. (453.6 kg); Lead: 10 lbs. (4.536 kg); Arsenic: 1 lbs. (0.4536 kg); Cadmium: 10 lbs. (4.536 kg);

State regulations

No products were found.

WARNING: This product contains a chemical known to the State of California to cause cancer. naphthalene; naphthalene; Ethyl acrylate; Arsenic

WARNING: This product contains a chemical known to the State of California to cause birth defects or other reproductive harm. Toluene

WARNING: This product contains a chemical known to the State of California to cause cancer and birth defects or other reproductive harm. Lead; Cadmium; Benzene

Inventories

AUSTRALIAN INVENTORY (AICS): Not determined.

CANADA INVENTORY (DSL): In compliance.

CHINA INVENTORY (IECS): Not determined.

EC INVENTORY (EINECS/ELINCS): Not determined.

JAPAN INVENTORY (ENCS): Not determined.

KOREA INVENTORY (ECL): Not determined.

PHILIPPINE INVENTORY (PICCS): Not determined.

16. Other information

Label requirements

CAUTION!

MAY CAUSE EYE IRRITATION.
MAY CAUSE SKIN IRRITATION.

HMIS® Rating :

Health 1
Flammability 1
Physical Hazard 0
Personal protection X

National Fire Protection Association (U.S.A.)



History

Date of issue

07/07/2005.

Product name	CASTROL DUAL RANGE HV 46 HYDRAULIC FLUID	MSDS #	460278	Page: 5/6
Version	1	Date of issue	07/07/2005.	Format US-FULL
				Language ENGLISH.
			Build 4.2.4	(ENGLISH)

Date of previous issue 07/02/2005.

Prepared by Product Stewardship

Notice to reader

NOTICE : This Material Safety Data Sheet is based upon data considered to be accurate at the time of its preparation. Despite our efforts, it may not be up to date or applicable to the circumstances of any particular case. We are not responsible for any damage or injury resulting from abnormal use, from any failure to follow appropriate practices or from hazards inherent in the nature of the product.

Product name	CASTROL DUAL RANGE HV 46 HYDRAULIC FLUID	MSDS #	460278	Page: 6/6
Version 1	Date of issue 07/07/2005.	Format US-FULL	Language ENGLISH.	
		Build 4.2.4	(ENGLISH)	

