

## RCS-2 PARTS, MAINTENANCE AND TROUBLESHOOTING

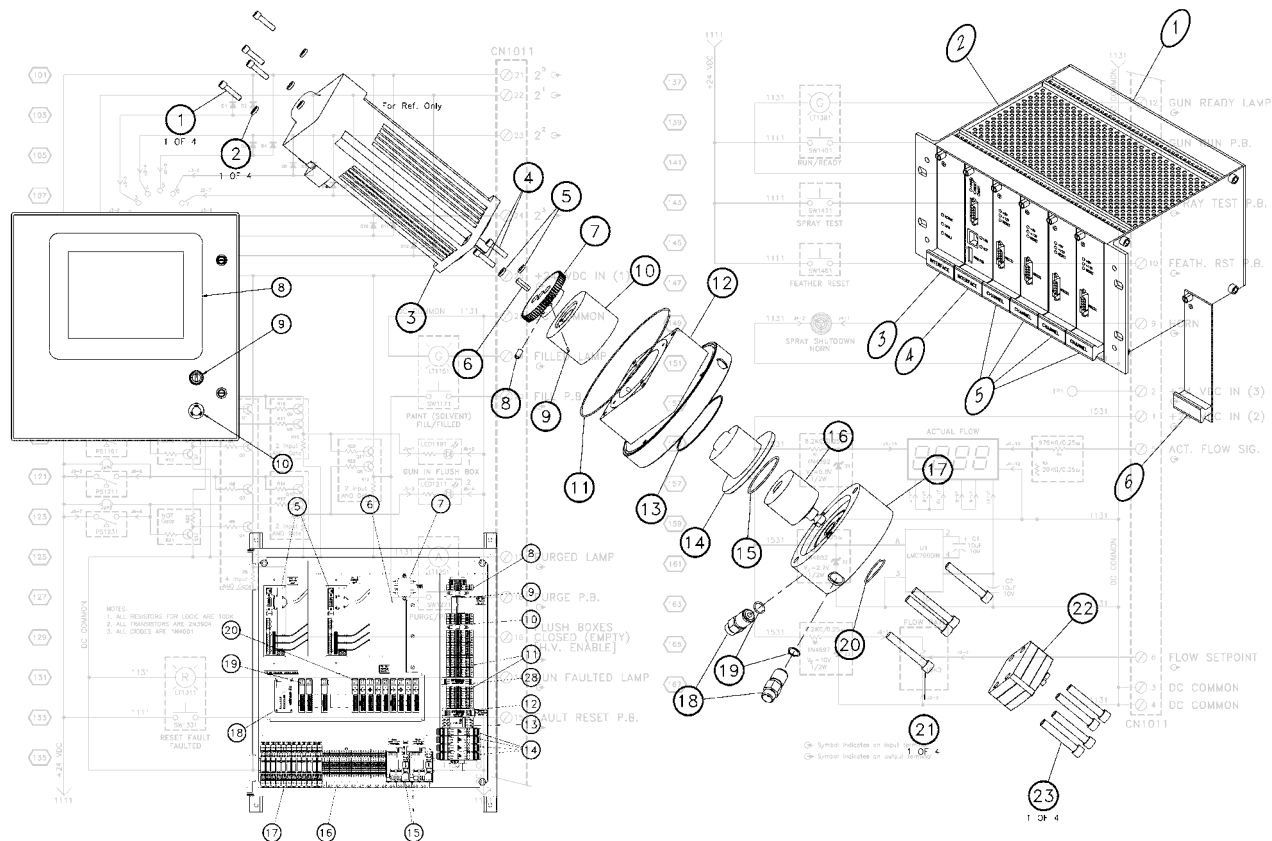

**MODELS:** A10549 Control Console  
A10776 Motor Amplifier Panel  
A10948 Fluid Panel  
A11095 Remote Operator's Panel

**IMPORTANT:** Before using this equipment, carefully read **SAFETY PRECAUTIONS**, starting on page 1, and all instructions in this manual. Keep this Service Manual for future reference.

**NOTE:** This service manual has been superseded from service manual number **LN-9408-06.2** to service manual number **LN-9408-06.3**. Reasons for this change are noted under "Manual Change Summary" inside the back cover of this manual.

---

# CONTENTS

---

	<b>PAGE</b>
<b>SAFETY:</b>	<b>1-5</b>
SAFETY PRECAUTIONS.....	1
HAZARDS / SAFEGUARDS.....	2-5
<b>MAINTENANCE:</b>	<b>6-19</b>
ELECTRICAL CONTROL PANELS.....	6-7
GEAR PUMPS.....	7-9
RESIN (FLUSHABLE) PUMP ASSEMBLY / PARTS LIST.....	10
ASSEMBLY 22-337 PUMP BYPASS.....	11-12
CATALYST (NON-FLUSHABLE) PUMP ASSEMBLY / PARTS LIST.....	14-16
PUMP BYPASS VALVE ASSEMBLY / PARTS LIST.....	18-19
<b>PARTS IDENTIFICATION:</b>	<b>20-47</b>
MAIN CONTROL CONSOLE / PARTS LIST.....	20-21
RACK ASSEMBLY / PARTS LIST.....	22
MOTOR AMPLIFIER PANEL / PARTS LIST.....	24-27
MOTOR AMPLIFIER PANEL MODEL IDENTIFICATION.....	28
REMOTE OPERATOR'S PANEL / PARTS LIST.....	30-31
REMOTE OPERATOR'S PANEL MODEL IDENTIFICATION.....	31
FLUID PANEL ASSEMBLY / PARTS LIST.....	32-34
FLUID PANEL ASSEMBLY MODEL IDENTIFICATION.....	35-36
NON-FLUSHABLE PUMP / MANIFOLD ASSEMBLY / PARTS LIST.....	38-39
FLUSHABLE PUMP / MANIFOLD ASSEMBLY / PARTS LIST.....	40-41
DUAL- HEADED PUMP ASSEMBLY / PARTS LIST.....	42-44
77671-00 5-WAY BALL VALVE ASSEMBLY / PARTS LIST.....	46-47
<b>TROUBLESHOOTING:</b>	<b>48-58</b>
BLOCK DIAGRAMS.....	48
RIBBON CABLE INTERCONNECT CHARTS.....	48
UMBILICAL CORD SIGNALS.....	48
CONTROL CONSOLE BLOCK DIAGRAM.....	49
MOTOR AMPLIFIER BLOCK DIAGRAM.....	50
FLUID PANEL BLOCK DIAGRAM.....	51
CHANNEL BOARD BLOCK DIAGRAM.....	52
INTERFACE BOARD BLOCK DIAGRAM.....	53
INTERCONNECT CHART FOR CHANNELS 1, 3, 5, AND 7.....	54
INTERCONNECT CHART FOR CHANNELS 2, 4, 6, AND 8.....	55
INTERCONNECT CHART FOR SYSTEM I/O SIGNALS.....	56
ODD NUMBERED CHANNEL UMBILICAL CORD SIGNALS.....	57
EVEN NUMBERED CHANNEL UMBILICAL CORD SIGNALS.....	58

(Continued On Next Page)

---

**CONTENTS (Continued)**

---

	<b>PAGE</b>
<b>WARRANTY POLICIES:</b>	<b>60</b>
LIMITED WARRANTY.....	60
<b>APPENDIX:</b>	<b>61-93</b>
APPENDIX A: UPDATING THE FIRMWARE AND SOFTWARE ON THE RCS-2.....	61-66
APPENDIX B: ERROR LOG CHART.....	67-69
APPENDIX C: MOTOR AMPLIFIER LED DISPLAY FAULT CODES (PART 1 AND 2).....	70-73
APPENDIX D: CALIBRATING THE PRESSURE TRANSDUCERS (PART 1 AND 2).....	74-75
APPENDIX E: RECOMMENDED SPARE PARTS .....	76-79
APPENDIX F: SYSTEM LAYOUT.....	80
APPENDIX G: SCHEMATICS.....	81-94

# SAFETY

## SAFETY PRECAUTIONS

Before operating, maintaining or servicing any Ransburg electrostatic coating system, read and understand all of the technical and safety literature for your Ransburg products. This manual contains information that is important for you to know and understand. This information relates to USER SAFETY and PREVENTING EQUIPMENT PROBLEMS. To help you recognize this information, we use the following symbols. Please pay particular attention to these sections.

**A WARNING!** states information to alert you to a situation that might cause serious injury if instructions are not followed.

**A CAUTION!** states information that tells how to prevent damage to equipment or how to avoid a situation that might cause minor injury.

**A NOTE** is information relevant to the procedure in progress.

While this manual lists standard specifications and service procedures, some minor deviations may be found between this literature and your equipment. Differences in local codes and plant requirements, material delivery requirements, etc., make such variations inevitable. Compare this manual with your system installation drawings and appropriate Ransburg equipment manuals to reconcile such differences.

Careful study and continued use of this manual will provide a better understanding of the equipment and process, resulting in more efficient operation, longer trouble-free service and faster, easier troubleshooting. If you do not have the manuals and safety literature for your Ransburg system, contact your local Ransburg representative or Ransburg.



### WARNING



- The user **MUST** read and be familiar with the Safety Section in this manual and the Ransburg safety literature therein identified.
- This manual **MUST** be read and thoroughly understood by **ALL** personnel who operate, clean or maintain this equipment! Special care should be taken to ensure that the **WARNINGS** and safety requirements for operating and servicing the equipment are followed. The user should be aware of and adhere to ALL local building and fire codes and ordinances as well as **NFPA-33 SAFETY STANDARD, LATEST EDITION**, prior to installing, operating, and/or servicing this equipment.



### WARNING



- The hazards shown on the following pages may occur during the normal use of this equipment. Please read the hazard chart beginning on page 2.

<b>AREA</b> Tells where hazards may occur.	<b>HAZARD</b> Tells what the hazard is.	<b>SAFEGUARDS</b> Tells how to avoid the hazard.
<p><b>Spray Area</b></p> 	<p><b>Fire Hazard</b></p> <p>Improper or inadequate operation and maintenance procedures will cause a fire hazard.</p> <p>Protection against inadvertent arcing that is capable of causing fire or explosion is lost if any safety interlocks are disabled during operation. Frequent Power Supply or Controller shutdown indicates a problem in the system requiring correction.</p>	<p>Fire extinguishing equipment must be present in the spray area and tested periodically.</p> <p>Spray areas must be kept clean to prevent the accumulation of combustible residues.</p> <p>Smoking must never be allowed in the spray area.</p> <p>The high voltage supplied to the atomizer must be turned off prior to cleaning, flushing or maintenance.</p> <p>When using solvents for cleaning:</p> <ul style="list-style-type: none"> <li>• Those used for equipment flushing should have flash points equal to or higher than those of the coating material.</li> <li>• Those used for general cleaning must have flash points above 100°F (37.8°C).</li> </ul> <p>Spray booth ventilation must be kept at the rates required by NFPA-33, OSHA, country, and local codes. In addition, ventilation must be maintained during cleaning operations using flammable or combustible solvents.</p> <p>Electrostatic arcing must be prevented. Safe sparking distance must be maintained between the parts being coated and the applicator. A distance of 1 inch for every 10KV of output voltage is required at all times.</p> <p>Test only in areas free of combustible material. Testing may require high voltage to be on, but only as instructed.</p> <p>Non-factory replacement parts or unauthorized equipment modifications may cause fire or injury.</p> <p>If used, the key switch bypass is intended for use only during setup operations. Production should never be done with safety interlocks disabled.</p> <p>Never use equipment intended for use in waterborne installations to spray solvent based materials.</p> <p>The paint process and equipment should be set up and operated in accordance with NFPA-33, NEC, OSHA, local, country, and European Health and Safety Norms.</p>

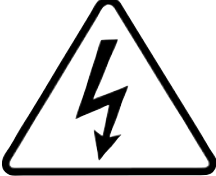
<p><b>AREA</b> Tells where hazards may occur.</p>	<p><b>HAZARD</b> Tells what the hazard is.</p>	<p><b>SAFEGUARDS</b> Tells how to avoid the hazard.</p>
<p><b>Spray Area</b></p> 	<p><b>Explosion Hazard</b></p> <p>Improper or inadequate operation and maintenance procedures will cause a fire hazard.</p> <p>Protection against inadvertent arcing that is capable of causing fire or explosion is lost if any safety interlocks are disabled during operation.</p> <p>Frequent Power Supply or Controller shutdown indicates a problem in the system requiring correction.</p>	<p>Electrostatic arcing must be prevented. Safe sparking distance must be maintained between the parts being coated and the applicator. A distance of 1 inch for every 10KV of output voltage is required at all times.</p> <p>Unless specifically approved for use in hazardous locations, all electrical equipment must be located <b>outside</b> Class I or II, Division 1 or 2 hazardous areas, in accordance with NFPA-33.</p> <p>Test only in areas free of flammable or combustible materials.</p> <p>The current overload sensitivity (if equipped) <b>MUST</b> be set as described in the corresponding section of the equipment manual. Protection against inadvertent arcing that is capable of causing fire or explosion is lost if the current overload sensitivity is not properly set. Frequent power supply shutdown indicates a problem in the system which requires correction.</p> <p>Always turn the control panel power off prior to flushing, cleaning, or working on spray system equipment.</p> <p>Before turning high voltage on, make sure no objects are within the safe sparking distance.</p> <p>Ensure that the control panel is interlocked with the ventilation system and conveyor in accordance with NFPA-33, EN 50176.</p> <p>Have fire extinguishing equipment readily available and tested periodically.</p>
<p><b>General Use and Maintenance</b></p> 	<p>Improper operation or maintenance may create a hazard.</p> <p>Personnel must be properly trained in the use of this equipment.</p>	<p>Personnel must be given training in accordance with the requirements of NFPA-33, EN 60079-0.</p> <p>Instructions and safety precautions must be read and understood prior to using this equipment.</p> <p>Comply with appropriate local, state, and national codes governing ventilation, fire protection, operation maintenance, and housekeeping. Reference OSHA, NFPA-33, EN Norms and your insurance company requirements.</p>

<p><b>AREA</b> Tells where hazards may occur.</p>	<p><b>HAZARD</b> Tells what the hazard is.</p>	<p><b>SAFEGUARDS</b> Tells how to avoid the hazard.</p>
<p><b>Spray Area / High Voltage Equipment</b></p> 	<p><b>Electrical Discharge</b></p> <p>There is a high voltage device that can induce an electrical charge on ungrounded objects which is capable of igniting coating materials.</p> <p>Inadequate grounding will cause a spark hazard. A spark can ignite many coating materials and cause a fire or explosion.</p>	<p>Parts being sprayed and operators in the spray area must be properly grounded.</p> <p>Parts being sprayed must be supported on conveyors or hangers that are properly grounded. The resistance between the part and earth ground must not exceed 1 meg ohm. (Refer to NFPA-33.)</p> <p>Operators must be grounded. Rubber soled insulating shoes should not be worn. Grounding straps on wrists or legs may be used to assure adequate ground contact.</p> <p>Operators must not be wearing or carrying any ungrounded metal objects.</p> <p>When using an electrostatic handgun, operators must assure contact with the handle of the applicator via conductive gloves or gloves with the palm section cut out.</p> <p><b>NOTE: REFER TO NFPA-33 OR SPECIFIC COUNTRY SAFETY CODES REGARDING PROPER OPERATOR GROUNDING.</b></p> <p>All electrically conductive objects in the spray area, with the exception of those objects required by the process to be at high voltage, must be grounded. Grounded conductive flooring must be provided in the spray area.</p> <p>Always turn off the power supply prior to flushing, cleaning, or working on spray system equipment.</p> <p>Unless specifically approved for use in hazardous locations, all electrical equipment must be located <b>outside</b> Class I or II, Division 1 or 2 hazardous areas, in accordance with NFPA-33.</p>



<p><b>AREA</b> Tells where hazards may occur.</p>	<p><b>HAZARD</b> Tells what the hazard is.</p>	<p><b>SAFEGUARDS</b> Tells how to avoid the hazard.</p>
<p><b>Electrical Equipment</b></p> 	<p><b>Electrical Discharge</b></p> <p>High voltage equipment is utilized in the process. Arcing in the vicinity of flammable or combustible materials may occur. Personnel are exposed to high voltage during operation and maintenance.</p> <p>Protection against inadvertent arcing that may cause a fire or explosion is lost if safety circuits are disabled during operation.</p> <p>Frequent power supply shut-down indicates a problem in the system which requires correction.</p> <p>An electrical arc can ignite coating materials and cause a fire or explosion.</p>	<p>Unless specifically approved for use in hazardous locations, the power supply, control cabinet, and all other electrical equipment must be located outside Class I or II, Division 1 and 2 hazardous areas in accordance with NFPA-33 and EN 50176.</p> <p>Turn the power supply OFF before working on the equipment.</p> <p>Test only in areas free of flammable or combustible material.</p> <p>Testing may require high voltage to be on, but only as instructed.</p> <p>Production should never be done with the safety circuits disabled.</p> <p>Before turning the high voltage on, make sure no objects are within the sparking distance.</p>
<p><b>Toxic Substances</b></p> 	<p>Certain material may be harmful if inhaled, or if there is contact with the skin.</p>	<p>Follow the requirements of the Material Safety Data Sheet supplied by coating material manufacturer.</p> <p>Adequate exhaust must be provided to keep the air free of accumulations of toxic materials.</p> <p>Use a mask or respirator whenever there is a chance of inhaling sprayed materials. The mask must be compatible with the material being sprayed and its concentration. Equipment must be as prescribed by an industrial hygienist or safety expert, and be NIOSH approved.</p>
<p><b>Spray Area</b></p> 		<p>Aluminum is widely used in other spray application equipment - such as material pumps, regulators, triggering valves, etc. Halogenated hydrocarbon solvents must never be used with aluminum equipment during spraying, flushing, or cleaning. Read the label or data sheet for the material you intend to spray. If in doubt as to whether or not a coating or cleaning material is compatible, contact your coating supplier. Any other type of solvent may be used with aluminum equipment.</p>

---

# MAINTENANCE

---

## ELECTRICAL CONTROL PANELS

### Main Control Console

There is minimal (if any) routine maintenance necessary on the main control console. There are no moving parts aside from the power and emergency stop switches on the door of the panel. A few things can be done from a preventative viewpoint to extend the life of the components in the control console:

- Keep the door closed at all times to keep dust, dirt, and moisture out of the control panel and off of the PC boards.
- Avoid touching the touch screen display with sharp objects or with hands or gloves that have paint on them. The screen is glass and a razor blade can be used to remove dried paint, etc., if absolutely necessary, however, it is best to avoid having to do this. If the glass is scratched in any way, it can effect how the touch screen responds when touched. (Sensitivity can be diminished by contaminants or scratches.)
- Make sure the quarter turn latch screws on the PC boards and on the rack are latched to prevent boards from vibrating loose over time.
- Make sure all latches are in the proper position to retain all ribbon cables in the control panel.
- Temperatures inside of the main control console run significantly above ambient. If it is expected that the ambient temperature will exceed 100° F, some form of external cooling will be required. Contact Ransburg for suggested methods.
- There are several different versions of the touchscreen PC used in the RCS-2, but all of

them employ cooling fans and air vents. On some of them, fans are visible on the outside frame of the computer and on others, they are internal to the PC. Periodically, check to make sure the fans are running and vent holes are not blocked by dust or other obstructions.

### Motor Amplifier Panels

There is minimal routine maintenance necessary on the motor amplifier panels. The only items in the motor amplifier panel that have moving parts are the power relay, the solenoid valves, and the E to P transducers. (The later two items are optional.) Note that the E to P transducers also have small in-line filters (P/N: SSM-5504) on their inlet ports that may need periodic replacement, depending on the quality of the air being delivered to the panel.

Similar to the aforementioned main control console, there are a few things to keep in mind to help extend the lives of the components in the motor amplifier panels:

- Keep the door closed at all times to keep dust, dirt, and moisture out of the control panel.
- Because the motor amplifiers can dissipate a significant amount of heat, temperatures inside of the motor amplifier panels can run as much as 20° F above ambient. If that will cause the internal temperature of the motor amplifier panel to rise above 120° F, some sort of external cooling may be required.
- It is recommended that the air supply to this panel be regulated to approximately 100 psi and filtered to at least 20 Microns.

## Remote Operator's Panel

As with the other control panels, there are not many items in the remote operator's panel that should require much routine maintenance. The only moving parts are the pushbuttons, color select switch, flow control potentiometer and the optional pressure and air-flow switches. All indicator lamps are LED's and should, therefore, never fail. A couple of items to keep in mind are listed below to insure uninterrupted service from the remote operator's panel:

- Keep the door closed at all times to keep dust, dirt, and moisture out of the control panel.
- Use dry, filtered (20 Micron's or less) air to pilot the pressure switches and supply the inlets to the air flow switches.

## Fluid Panels

As with all fluid delivery and control systems, the part of the system that sees the most wear and tear and will require the most maintenance and repair is the section that actually makes contact with the fluids. In the case of the RCS-2, this section is referred to as the fluid panel.

The fluid panel portion of the RCS-2 is basically a stainless steel plate with most of the components that come in contact with the fluids being metered mounted on it. All wetted components are stainless steel other than the physical pumps themselves. In most cases, the pumps are manufactured from M2 tool steel, which gives them superb wear resistance over similar designs manufactured from stainless steel.

Each of the individual components on the fluid panel will be discussed below as to how it operates and how to service it.

## GEAR PUMPS

**This section explains "How to Disassemble, Clean, and Reassemble the Gear Pump".**

### Introduction

The magnetically coupled gear pump is a precision tool designed to provide highly accurate performance over an extended service life. The gear pump is constructed of precisely machined components with tight running tolerances of 0.00025 inches. Burrs, nicks, or particles of foreign matter can score an internal surface or cause the pump to seize up. The ability of the unit to deliver the performance level it was designed for depends on the user closely following several essential requirements:

- Never let a pump run dry
- Never pump contaminated fluids
- Never reuse any seal (Always replace separated seals with a new seal.)
- Consult the factory before using micas, metallic's, or waterborne coatings
- Provide advance filtration for all fluids
- Provide skilled and careful maintenance
- Respect exceptionally close tolerances

### Gear Pump Operation

The gear pump's internal bearing surfaces are lubricated by the metered fluids being pumped through the assembly. The recommended operating speed range for these pumps is between 3 and 150 rpm. Pump speeds over 150 rpm are not recommended.

Increasing the pump's operating speed improves its efficiency, but also shortens the time fluid is allowed to fill the gear tooth spaces and lubricate the bearing surfaces. Failure to fill the tooth spaces allows air into the pump and can cause low delivery, excessive wear, reduced seal life, and internal cavitation.

## Magnetic Coupling

There is no rotating shaft connecting the servo motor to the gear pump. Instead, this product employs a magnetic coupling to transfer power from the servo motor to the positive displacement gear pump. The magnetic coupling provides several advantages over conventional rotary shaft systems:

- **Protects servo motor from paint leaks**  
The magnetic coupling provides a physical barrier between the servo motor and the gear pump, and serves to protect the servo motor from paint leakage.
- **Make seals less critical**  
The seals are less critical than in a conventional rotary shaft system. If seals leak in the pump, the system will still operate without the danger of paint entering the drive system.
- **Provide more up-time**  
Since the seals are less critical and the magnetic coupling is durable, the system delivers higher equipment utilization and shorter maintenance procedures.
- **Lasts longer**  
The magnetically coupled gear pump and motor will have a longer operational life than a conventional rotary shaft system.

## Applications

Because of the precise servo control and rapid acceleration and deceleration of paint delivery, this product is ideally suited for almost all automotive or industrial applications. This product will provide superior delivery in applications that require:

- High performance paint metering
- Single and multi-component applications
- Precision flow rates
- Quick and accurate flow rate changes

## Pumps, Color (Resin), and Hardener (Catalyst)

Some coating applications using the magnetically coupled gear pump require two fluids to be metered. Thus, there are two styles of pumps:

- Color Pump (Resin), which are flushable
- Hardener Pump (Catalyst) which are non-flushable.

The parts of each pump are similar. Except for plate configuration, the main difference between the two styles is the seal plate on the hardener pump. This section covers both pumps and the instructions will identify where the procedure only applies to one style.

## Restricted Materials

Paints and fluids for use with this system must meet the following conditions:

- Non-abrasive materials
- Maximum entrained particle size: 6 microns (0.00025")
- Maximum hardness: Rc 55
- Concentration of entrained particles should not exceed 20% of total fluid volume.

Contact Ransburg for technical assistance on applications involving metallics, micas, or water-borne systems.

## Applicable Models and Styles

The Service Information in this manual covers two basic product styles:

- **Flushable**  
The flushable style pumps meter color and incorporates a pump bypass assembly.
- **Non-flushable**  
The non-flushable style pumps meter hardener and does not have a bypass assembly.

**NOTE**

► Although uncommon, there are applications for flushable hardener pumps and for non-flushable color pumps.

**Major Components**

The major components of the flushable magnetically coupled gear pumps include:

- **Bypass Assembly (Flushable units only)**  
Allows rapid flushing of the pump.
- **Gear Pump**  
Is made from precision machined parts with tolerances of 0.00025". The gear pump is the heart of the delivery system and controls the flow of paint for a precise, accurate coating.
- **Manifold**  
Connects gear pump to magnetic coupling.
- **Magnetic Coupling**  
Transfers rotary motion from the servo motor to the gear pump.
- **Servo Motor**  
Transfers rotary motion from the servo motor to the gear pump through the magnetic coupling.

**Performance Capabilities**

Both magnetically coupled gear pumps use a UL approved servo motor. Explosion proof servo motors rated for hazardous duty in Class I, Division 1, Groups C and D environments are available as an option.

**General Handling**

The magnetically coupled gear pump assembly is a precision tool designed to provide highly accurate performance over an extended service life. The ability of the unit to deliver the performance level it was designed for depends on the user closely following several essential requirements:

- Never let the pump run dry
- Never pump contaminated fluids
- Never reuse any seal
- Always replace damaged or worn seals with a new seal
- Consult the factory before using micas, metallic's, or waterborne systems
- Provide advance filtration for suspect fluids
- Provide skilled and careful maintenance
- Respect exceptionally close tolerances

**Precision Metering Pump**

The heart of the system is the high precision metering gear pump constructed of M2 tool steel. To maintain the gear pump assembly in factory-new condition, the guidelines and procedures for pump servicing covered in this manual should be carefully followed.

With tight running tolerances of a remarkable 0.00025 inches, there can be no allowance of casual handling that might be appropriate for a less exacting assembly. Burrs, nicks, or particles of foreign matter could score an internal surface or cause the pump to seize up.

**System Start-Up**

Pump assemblies are shipped from the factory protected with rust preventive oil. Remove this oil before using the system. To remove oil, flush and purge the system with solvent.

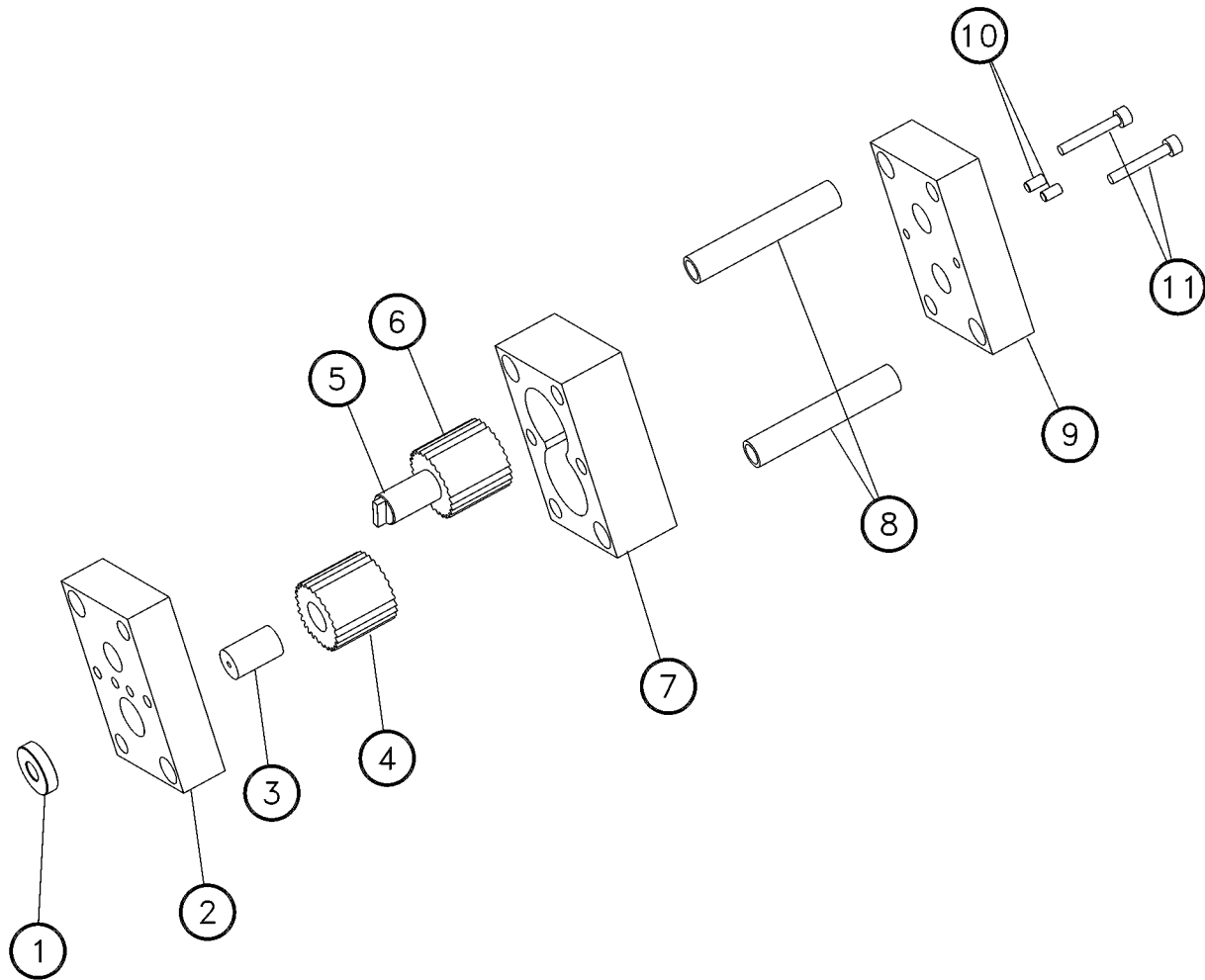

Figure 1: Resin (Flushable) Pump Assembly

RESIN (FLUSHABLE) PUMP ASSEMBLY - PARTS LIST (Figure 1)			
Item #	Part #	Description	Qty
1	22-383 *	Lip Seal	1
2	N.F.R. **	Front Side Plate	1
3	N.F.R.	Arbor	1
4	N.F.R.	Driven Gear	1
5	N.F.R.	Drive Shaft	1
6	N.F.R.	Driving Gear	1
7	N.F.R.	Center Plate	1
8	N.F.R.	Hollow Dowel	2
9	N.F.R.	Rear Side Plate	1
10	Varies ***	Roll Pin	4
11	Varies ***	Socket Head Cap Screw	4

\* Required Seal Insertion Tool, P/N: 22-543

\*\* Not Field Replaceable

\*\*\* Varies based on pump size

## ASSEMBLY 22-337 PUMP BYPASS

Flushable gear pumps have an air activated cylinder with two (2) ports that allow flushing of coating material from the gear pump. This feature reduces the time required to fill or purge the pump of paint. (See "Pump Bypass Valve Assembly" in the "Maintenance" section.)

### NOTE

- ▶ Opening the pump bypass valve is not recommended on plural component materials.

### Gear Pump Disassembly

#### CAUTION

- ▶ Be careful not to scratch or nick any surface of the plates, seals, gears, and dowels inside the pump. These parts have very precise tolerances. Burrs, nicks, scratches, or particles of foreign matter will cause scoring and possibly pump seizure.

1. Remove the four (4) socket head cap screws attaching the pump to the manifold.
2. Remove S.H.C. screws [11].
3. Using an arbor press, remove two (2) dowels [8] from the pump assembly.

### NOTE

- ▶ If an arbor press is unavailable, an alternate disassembly method is to partially back-off the cap screws and tap the screws with a soft head hammer. With the screw heads exposed, continue to alternate backing-out the screws and tapping the screws until the plates are free.

#### CAUTION

- ▶ Never tap on tang!

4. Separate front plate [2] from center plate [7], and from rear plate [9].
5. Remove driving gear [6] from center plate [7].
6. Remove driven gear [4] from center plate [7].
7. Remove arbor [3] from driven gear [4].

### Gear Pump Reassembly

Before reassembling the gear pump, clean and inspect all parts for damage or wear.

#### To Assemble:

1. If parts were separated, use a press to press arbor [3] into front side plate [2].
2. Insert driven metering gear [4] into center plate [7]. Manually turn the metering gear to ensure it moves freely.

#### CAUTION

- ▶ If the metering gear binds, it could damage the pump. Determine the cause of the binding. Nicks, burrs, or foreign particles can cause pump binding.

3. Insert driving metering gear [6] into center plate [7]. Manually turn the metering gear to ensure it moves freely.
4. Assemble rear [9], center [7], and front [2] plates.
5. Using an arbor press, press-fit two (2) dowels [8] into the plate assembly.
6. Lubricate roll pins [10] and cap screws [11] with petroleum jelly.
7. Insert roll pins [10] and cap screws [11] into rear plate [9] and thread them through all three (3) plates. Torque to 160 lbs•in.
8. After assembly, check torque by turning driving gear (torque not to exceed 4 lbs•in).

### **Drive Gear and Shaft**

In case of separate damage or wear, the drive gear [6] and drive shaft [5] may need to be separated and replaced. (Individual pump parts are not field replaceable and must be returned to for replacement.) To separate, use an arbor press to remove the gear [6] from the drive shaft. In reassembly, position the bottom of the gear .909" +/- .003" from the bottom of the shaft (end opposite the tang). Ransburg can supply a Gear Alignment Gauge for this purpose. The tool is P/N: 11-1032. Contact Ransburg for additional information.

### **Hollow Dowel**

Ransburg can supply special tools to achieve proper placement of the hollow dowels [8] in the gear plates. The dowel should extend .093" +/- .005" above the end plate on the pump shaft end (tang end). To allow dowel placement from either end of the pump, two tools are required:

- Dowel Insertion Tool - Male  
P/N: 22-1033
- Dowel Insertion Tool - Female  
P/N: 22-1034

## **NOTES**



**NOTES**

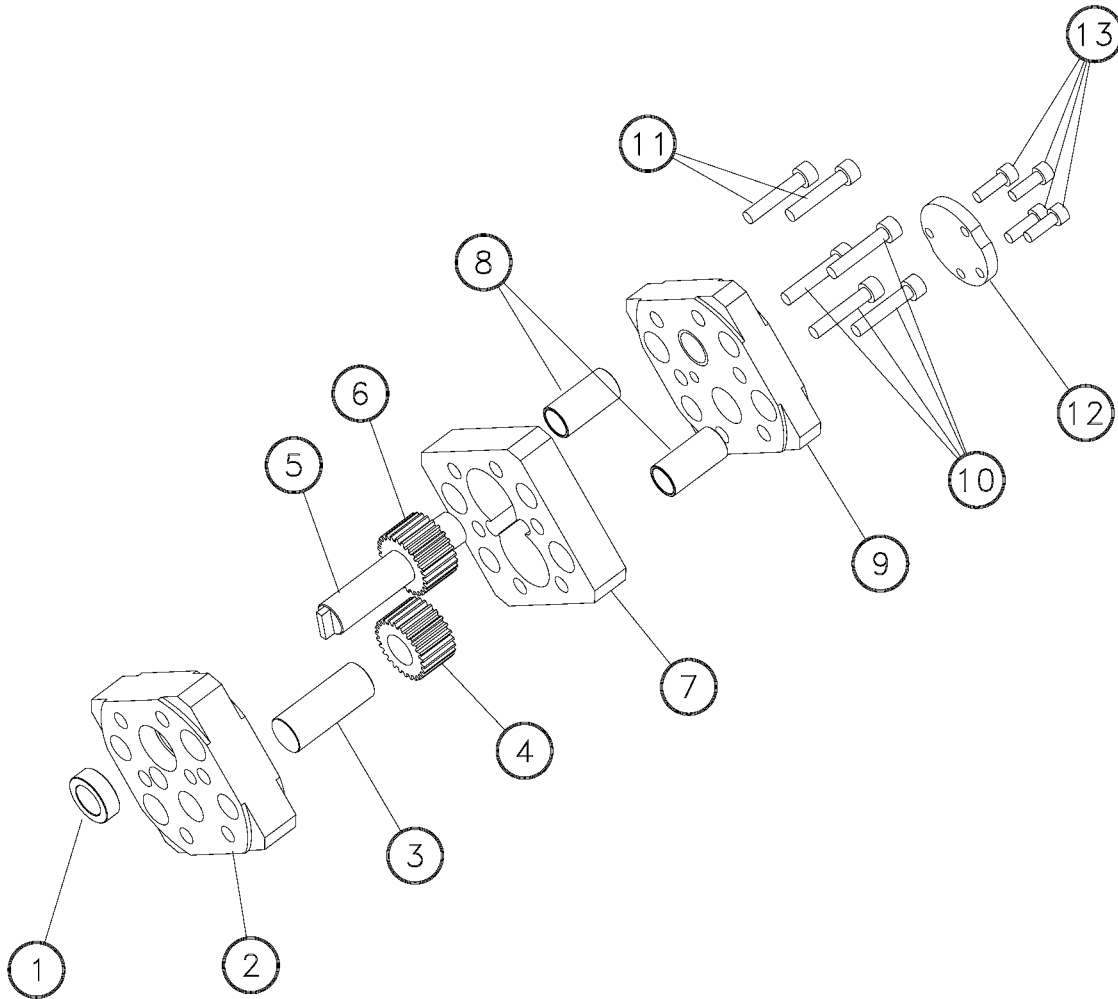

**Figure 2: Catalyst (Non-Flushable) Pump Assembly**

**CATALYST (NON-FLUSHABLE) PUMP ASSEMBLY - PARTS LIST (Figure 2)**

Item #	Part #	Description	Qty
1	22-383 *	Lip Seal	1
2	N.F.R. **	Front Side Plate	1
3	N.F.R.	Arbor	1
4	N.F.R.	Driven Gear	1
5	N.F.R.	Drive Shaft	1
6	N.F.R.	Driving Gear	1
7	N.F.R.	Center Plate	1
8	N.F.R.	Hollow Dowel	2
9	N.F.R.	Rear Side Plate	1
10	Varies ***	Long Cap Screw	4
11	Varies ***	Short Cap Screw	2
12	N.F.R.	Seal Plate	1
13	Varies ***	Socket Head Cap Screw	4

\* Requires Seal Insertion Tool P/N: 22-542

\*\* Not Field Replaceable

\*\*\* Varies based on pump size

## Non-Flushable Gear Pump Disassembly

### NOTE

► It is not recommended to disassemble these pumps in the field unless absolutely necessary. If a malfunction occurs, they should be returned to Ransburg for service.

### CAUTION

► Be careful not to scratch or nick any surface of the plates, seals, gears, and dowels inside the pump. These parts have very precise tolerances. Burrs, nicks, scratches, or particles of foreign matter will cause scoring and possibly pump seizure.

1. Remove the four (4) socket head cap screws attaching the pump to the manifold.
2. Remove the seal plate [12].
3. Remove bolts [10] and [11].
4. Using an arbor press, remove the two (2) dowels [8] from the front plate [2], center plate [7], and rear plate [9].

### NOTE

► If an arbor press is unavailable, an alternate disassembly method is to partially back-off the cap screws and tap the screws with a soft head hammer. With the screw heads exposed, continue to alternate back-ing-out the screws and tapping the screws until the plates are free.

### CAUTION

► Never tap on tang!

5. Separate front plate [2] from center plate [7].
6. Separate center plate [7] from rear plate [9].
7. Remove rear plate [9].
8. Remove driving gear [6] from center plate [7].
9. Remove driven gear [4] from center plate [7].
10. Remove arbor [3] from driven gear [4].

## Non-Flushable Gear Pump Reassembly

Before reassembling the gear pump, clean and inspect all parts for damage or wear.

### To Assemble:

1. If parts were separated, use a press to press arbor [3] into front side plate [2].
2. Insert driven gear [4] into center plate [7]. Man-

### CAUTION

► If the gear binds, it could damage the pump. Determine the cause of the binding. Nicks, burrs, or foreign particles can cause pump binding.

- ually turn the gear to ensure it moves freely.
3. Insert driving gear [6] into center plate [7]. Manually turn the gear to ensure it moves freely.
  4. Assemble rear [9], center [7], and front [2] plates.
  5. Using an arbor press, press-fit two (2) dowels [8] into the plate assembly.
  6. Lubricate cap screws [10] and [11] with petroleum jelly.
  7. Insert cap screws [10] and [11] into rear plate [9] and thread them through all three (3) plates.

**NOTE**

► The non-flushable pump uses two (2) short cap screws [11] and four (4) long cap screws [10] that extend through to the four (4) threaded holes in the front side plate [2]. torque to 120 lbs•in.

8. Install seal plate [12] onto rear plate [9] using four (4) socket head cap screws [13]. Torque to 50 lbs•in.

9. After assembly, check torque by turning drive gear (torque not to exceed 4 lbs•in).

**Drive Gear and Shaft**

In case of separate damage or wear, the drive gear [6] and drive shaft [5] may need to be separated and replaced. (Individual pump parts are not field replaceable and must be returned to for replacement.) To separate, use an arbor press to remove the gear [6] from the drive shaft. In reassembly, position the bottom of the gear .909" +/- .003" from the bottom of the shaft (end opposite the tang). Ransburg can supply a Gear Alignment Gauge for this purpose. The tool is P/N: 22-1032. Contact Ransburg for additional information.

**Hollow Dowel**

Ransburg can supply special tools to achieve proper placement of the hollow dowels [8] in the gear plates. The dowel should extend .093" +/- .005" above the end plate on the pump shaft end (tang end). To allow dowel placement from either end of the pump, two tools are required:

- Dowel Insertion Tool - Male -  
P/N: 22-1033
- Dowel Insertion Tool - Female -  
P/N: 22-1034

**NOTES**

**NOTES**

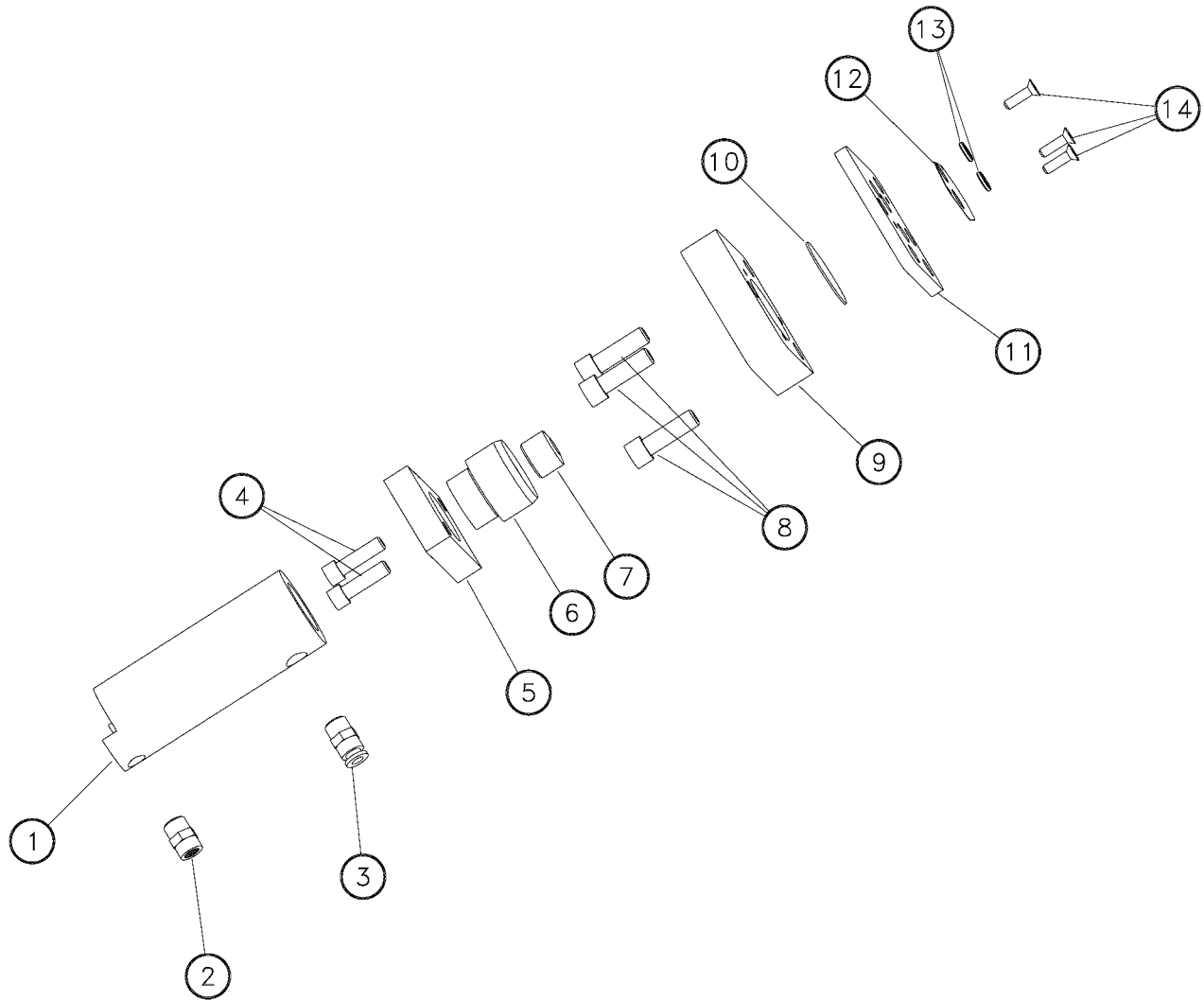

Figure 3: Pump Bypass Valve Assembly

PUMP BYPASS VALVE ASSEMBLY - PARTS LIST (Figure 3)			
Item #	Part #	Description	Qty
1	97-2396	Double Acting Cylinder	1
2	LS0012	Breather	1
3	41-FTP-1018	5/32" ODT X 1/8" NPT Tube Fitting	1
4	7959-28C	1/4"-20 X 7/8" L, SHCS	2
5	77303-00	Clamp Block	1
6	97-2009	Bushing	1
7	77306-00	Plunger	1
8	8532-32C *	5/16"-18" X 1" L, SHCS	3
9	22-399 *	Adapter Plate	1
10	97-2019	Diaphragm	1
11	22-398 *	Manifold Plate	1
12	22-403	Gasket	1
13	22-336	Seal	1
14	9158-16C	#8-32 X 50" L, Flat Head, Slotted Machine Screw	3

\* Part of P/N: 22-402 Manifold Assembly

## PUMP BYPASS VALVE ASSEMBLY

This section describes the "Procedures for Flushing, Removing, and Replacing the Bypass On the Flushable Magnetically Coupled Gear Pump".

### Introduction

The flushable magnetic gear pump has a pump bypass assembly which allows cleaning of paint from the gear pump by allowing paint, solvent, or a solvent-air mixture to bypass the gears, thus reducing flush and load times. Typically, the bypass is mounted on the pump which meters color.

#### NOTE

- ▶ It is possible (however uncommon) to use a bypass valve on a hardener pump. Don't assume that a pump with a bypass is always a color pump.

### Servicing the Pump Bypass Valve

#### Assembly

Unlike other components for which all broken seals must be replaced before reassembly, two (2) of the fluid seals in the bypass need only be replaced if damaged or worn.

#### Guidelines for bypass parts replacement:

- O-Ring Seals [13]: always replace after disassembly.
- Gasket [12]: replace only if there is visible wear or damage. Always replace after disassembly.
- Diaphragm [10]: replace only if there is visible wear or damage. Always replace after disassembly.

#### To Disassemble:

1. Remove two (2) screws [4] from clamp block [5].
2. Remove bushing [6] and plunger [7] from clamp block [5].
3. Remove three (3) screws [8] holding adapter plate [9] and manifold plate [11] to gear pump. Handle plates carefully to avoid damage to gasket [12].
4. Remove three (3) screws [14] holding adapter plate [9] to manifold plate [11]. Separate plates carefully to avoid damaging diaphragm [10].

#### To Reassemble:

1. Place diaphragm [10] in recess in adapter plate [9].
2. Install three (3) screws [14] to fasten manifold plate [11] to adapter plate [9].
3. Install two (2) seals [13] and gasket [12] on manifold plate [11].
4. Install three (3) screws [8] to fasten adapter plate [9] to gear pump.
5. Insert plunger [7] and bushing [6] into clamp block [5].
6. Install two (2) screws [4] to fasten clamp block [5] to adapter plate [9]. This completes assembly.

# PARTS IDENTIFICATION

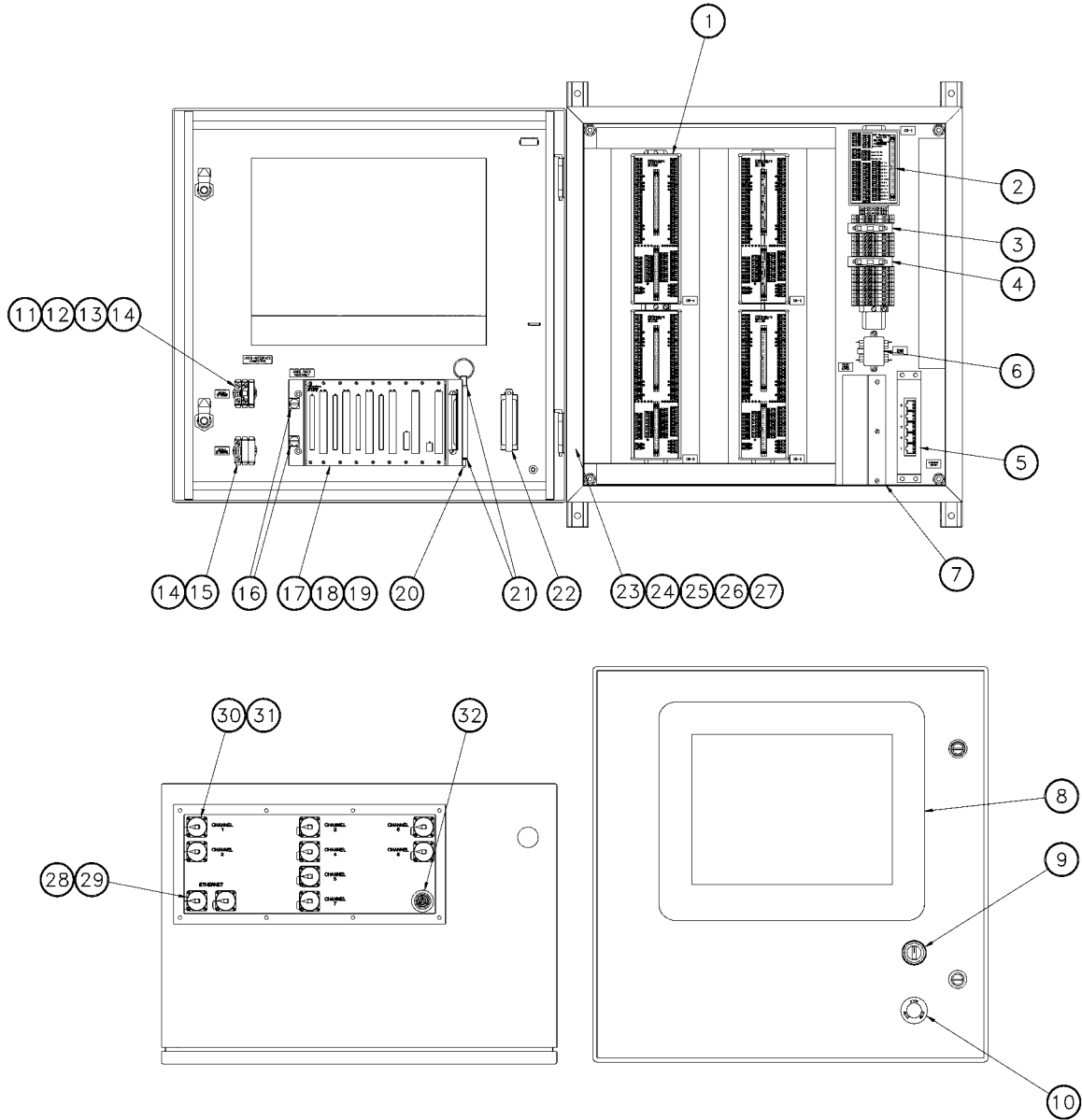

Figure 4: Main Control Console



**Part Number Tabulation:**

A10549-02 = 2 Channel Controller

A10549-04 = 4 Channel Controller

A10549-05 = 6 Channel Controller

A10549-08 = 8 Channel Controller

MAIN CONTROL CONSOLE - PARTS LIST (Figure 4)						
Item #	Part #	Description	Quantity Required			
			-02	-04	-06	-08
1	A10554-00	Terminal Board Assembly, DynaPump	1	2	3	4
2	A11530-00	64 Pin IDC Ribbon Cable, Interconnect Board	1	1	1	1
3	TR-SSEH-472	AGC-10, 10 Amp Fuse	1	1	1	1
4	TR-SSEH-471	AGC-5, 5 Amp Fuse	1	1	1	1
5	A10998-00	Ethernet Switch, 5 Port, Compact	1	1	1	1
6	22-1108	Power Line Filter	1	1	1	1
7	78835-00	Power Supply, 24VDC @ 180 Watts	1	1	1	1
8	A10705-02 *	Touch Screen, PC Assembly	1	1	1	1
9	76948-00	Switch, Selector, Maintained	1	1	1	1
10	77384-00	Switch, Mushroom Head, E-Stop, Red	1	1	1	1
11	LSME0005-00	Contact Block, Normally Open	1	1	1	1
12	LSME0007-00	Pilot Light Block	1	1	1	1
13	74300-00	Pilot Light, 130 Volt	1	1	1	1
14	LSME0004-00	Contact Clip, 3 Position	2	2	2	2
15	LSME0006-00	Contact Block, Normally Closed	1	1	1	1
16	77403-00	Receptacle, Push-On, Oval Slot Stud	2	2	2	2
17	A10530-00	Rack Sub-Assembly, DynaPump	1	1	1	1
18	78818-00	Interface Board Assembly, RCS-2	1	1	1	1
19	78814-00	Channel Board Assembly, RCS-2	1	2	3	4
20	77423-00	Pin, Detented	1	1	1	1
21	77429-01	Shoulder Washer, Nylon	2	2	2	2
22	77400-00	Cable Mount, Ribbon, 4"	1	1	1	1
23	A10586-01	64 Conductor Ribbon Cable, X 71" Lg.	1	1	1	1
24	A10586-02	64 Conductor Ribbon Cable, X 81" Lg.	1	2	3	3
25	A10586-03	64 Conductor Ribbon Cable, X 92" Lg.	0	0	0	1
26	A10587-01	50 Conductor Twisted PR Ribbon Cable, X 80" Lg.	1	1	1	1
27	A10587-02	50 Conductor Twisted PR Ribbon Cable, X 100" Lg.	0	1	2	3
28	A10795-00	Industrial Ethernet Bulkhead Receptical	2	2	2	2
29	A10918-00	Dust Cap for A10795-00	2	2	2	2
30	A10564-0X	Cable Assembly, 26 Socket Bulkhead (X=Channel Number)	2	4	6	8
31	A10817-00	Dust Cap for A10564	2	4	6	8
32	LSME0024-00	Horn, 24VDC	1	1	1	1

\* Touch screen may vary slightly from one shown.

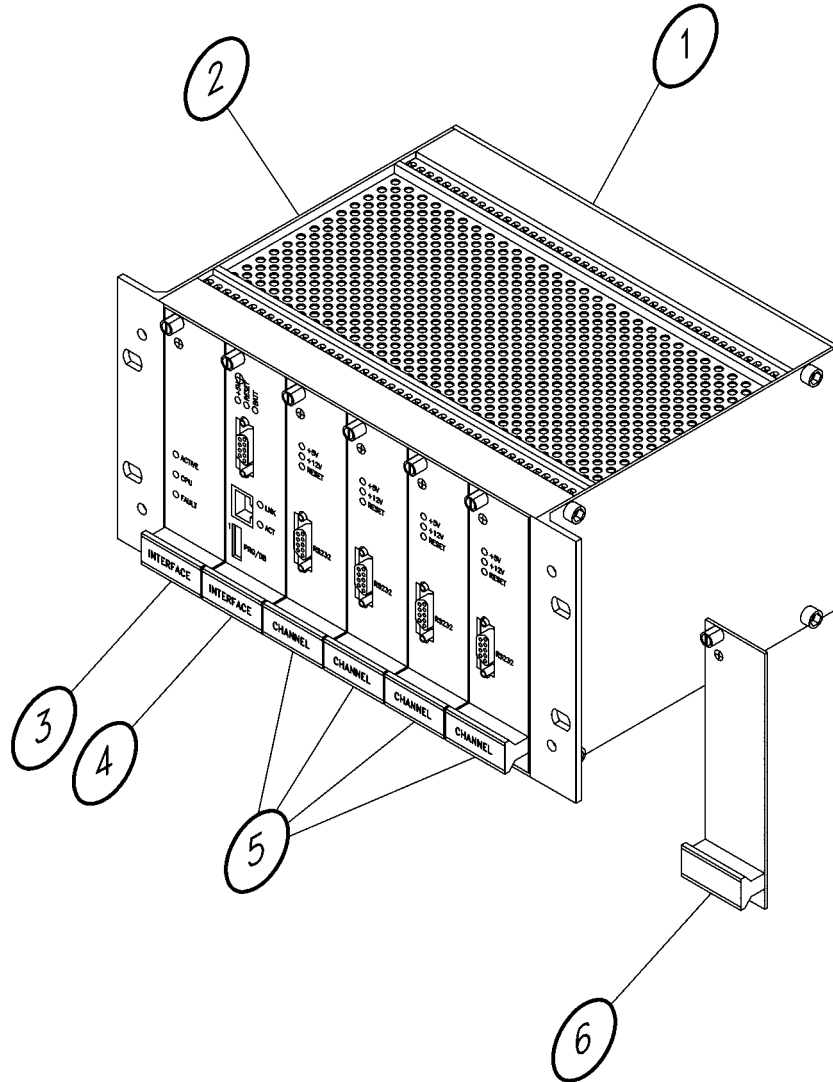

Figure 5: Rack Assembly

RACK ASSEMBLY - PARTS LIST (Figure 5)			
Item #	Part #	Description	Qty
1	78816-00	Backplane Board Assembly, RCS-2	1
2	A10530-00	Rack Sub-Assembly, RCS-2	1
3	77377-22 *	Interface Board, RIO, RCS-2	0-1
4	78818-00	Interface Board Assembly, RCS-2	1
5	78814-01 or 02 **	Channel Board Assembly, RCS-2	1-4
6	75086-01 ***	Cover Assembly	0-4

\* Only required if using vBradley RIO.

\*\* Quantity dependant on number of Channels required.

\*\*\* Cover plates used to fill unused slots.

**NOTES**

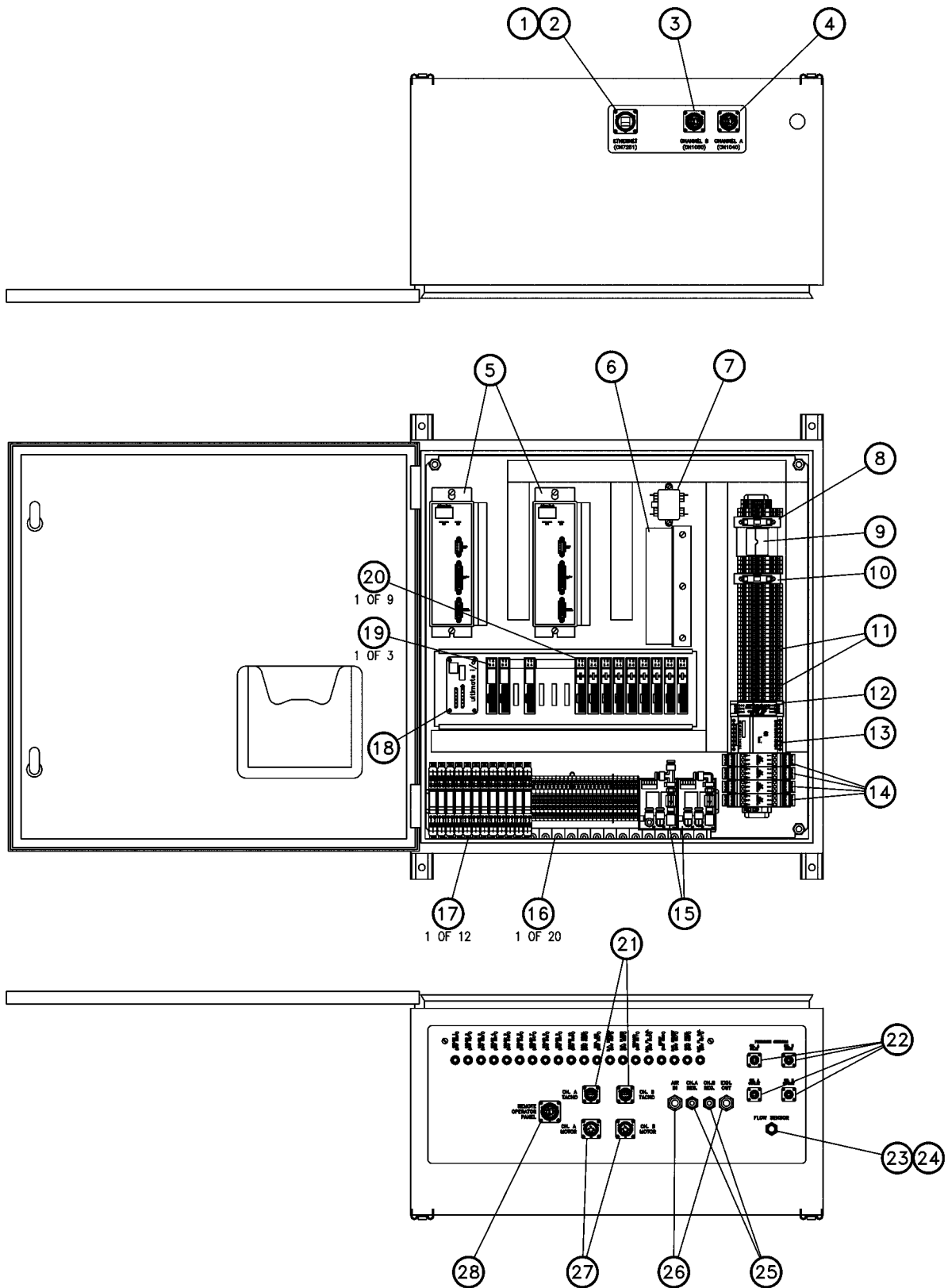

Figure 6a: Old Style Motor Amplifier Panel

<b>OLD STYLE MOTOR AMPLIFIER PANEL - PARTS LIST (Figure 6a)</b>			
<b>Item #</b>	<b>Part #</b>	<b>Description</b>	<b>Qty</b>
1	A10795-00	Ethernet Industrial Bulkhead W/RJ-45 Connector	1
2	A10798-00	Ethernet Cable (Not Shown)	1
3	A10564-09	26 Socket Bulkhead Assembly W/Flying Leads	1
4	A10564-10	26 Socket Bulkhead Assembly W/Flying Leads	1
5	A10783-01	Motor Drive (Amplifier)	2
6	A11389-00 *	Power Supply, 5VDC & 24VDC, 180 W	1
	78835-01 **	Power Supply, 24VDC, 180 W	1
7	22-1108	Power Line Filter	1
8	TR-SSEH-472	AGC-10, 10 Amp Fuse	1
9	SSS-7016	24VDC Relay	1
10	TR-SSEH-471	AGC-5, 5 Amp Fuse	1
11	A10781-00	Special Signal Inverting Terminal Block	2
12	22-1050	Flow Switch Amplifier	1
13	22-1046	Flow Monitor Control Unit	1
14	22-1245	Zener Barrier for 4-20mA	4
15	78643-00	Transducer Assembly, E to P	2
16	41-VSO-1005	24VDC Solenoid Valve Assembly	20
17	73837-08	Zener Barrier for Voltage	12
18	A10785-01	Opto-22 Brain W/Ethernet (Programmed)	1
19	A10786-00	Opto-22 DC Input Module	3
20	A10787-00	Opto-22 DC Output Module	9
21	A10793-00	Tachometer Bulkhead Cable Assembly, RCS-2 Motor Amp Panel	2
22	A10796-00	Bulkhead Connector, 4-Pin, Amphenol	4
23	76965-00	Cable Strain Relief, Liquid Tight	1
24	22-1045	Flow Sensor Cable Assembly	1
25	41-FBH-1000	1/4" ODT Bulkhead	"C" ***
26	41-FBH-1001	3/8" ODT Bulkhead	"C" ***
27	A10789-00	Motor Drive Bulkhead Cable Assembly, RCS-2 Motor Amp Panel	2
28	A10974-00	26 Socket Bulkhead Assembly	"B" ***

\* Used only if the optional Color Change Sequencer is installed.

\*\* Used only if the optional Color Change Sequencer is not installed.

\*\*\* Refer to "Motor Amplifier Panel Model Identification" for quantities.

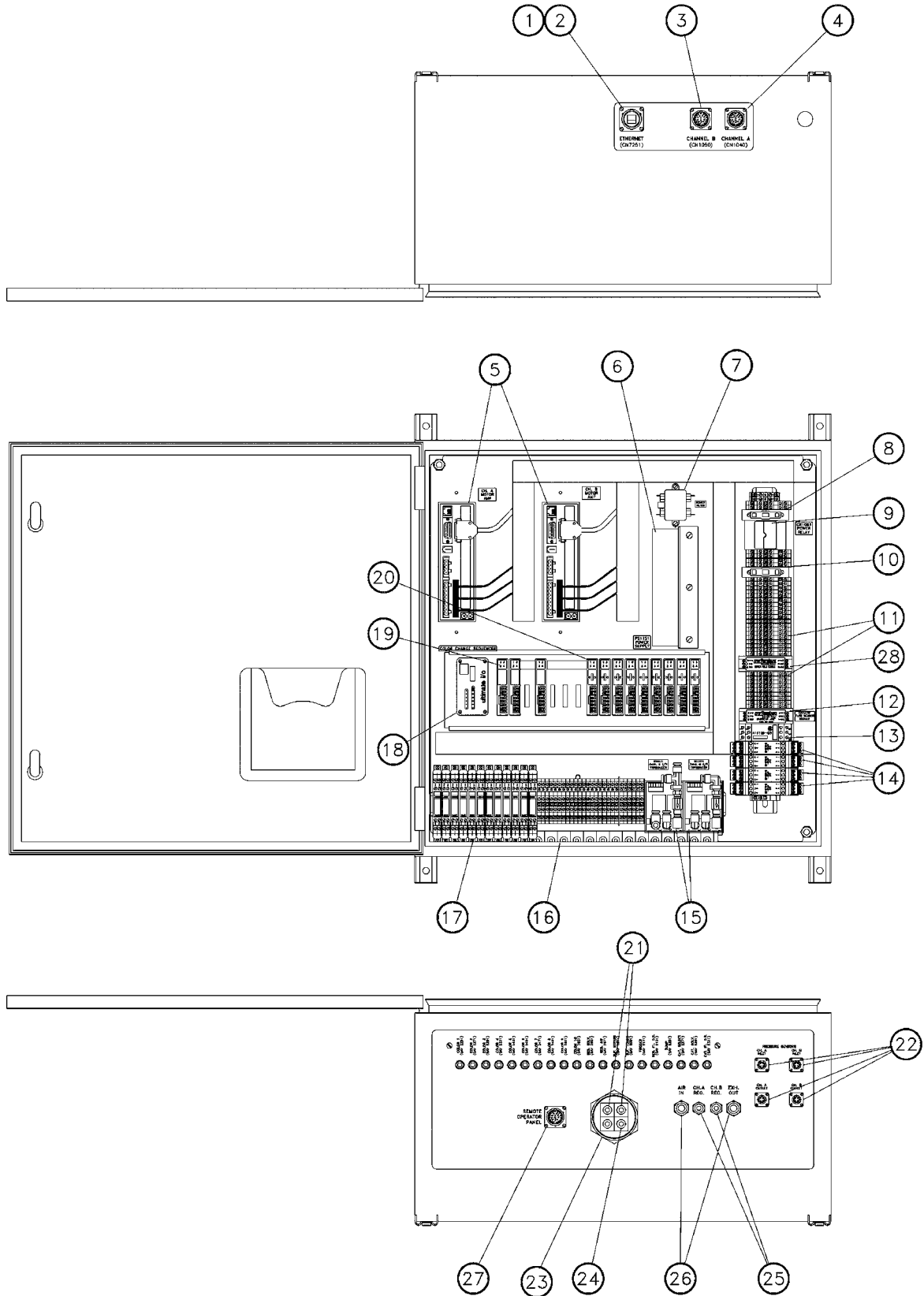

Figure 6b: New Style Motor Amplifier Panel

<b>NEW STYLE MOTOR AMPLIFIER PANEL - PARTS LIST (Figure 6b)</b>			
<b>Item #</b>	<b>Part #</b>	<b>Description</b>	<b>Qty</b>
1	A10795-00	Ethernet Industrial Bulkhead W/RJ-45 Connector	1
2	A10798-00	Ethernet Cable (Not Shown)	1
3	A10564-09	26 Socket Bulkhead Assembly W/Flying Leads	1
4	A10564-10	26 Socket Bulkhead Assembly W/Flying Leads	1
5	A12219-01	Motor Amplifier, S200	2
6	A11389-00 *	Power Supply, 5VDC & 24VDC, 180 W	1
	78835-01 **	Power Supply, 24VDC, 180 W	1
7	22-1108	Power Line Filter	1
8	TR-SSEH-472	AGC-10, 10 Amp Fuse	1
9	SSS-7016	24VDC Relay	1
10	TR-SSEH-471	AGC-5, 5 Amp Fuse	1
11	A10781-00	Special Signal Inverting Terminal Block	2
12	22-1050	Flow Switch Amplifier	1
13	22-1046	Flow Monitor Control Unit	1
14	22-1245	Zener Barrier for 4-20mA	4
15	78643-00	Transducer Assembly, E to P	2
16	41-VSO-1005	24VDC Solenoid Valve Assembly	20
17	73837-08	Zener Barrier for Voltage	12
18	A10785-01	Opto-22 Brain W/Ethernet (Programmed)	1
19	A10786-00	Opto-22 DC Input Module	3
20	A10787-00	Opto-22 DC Output Module	9
21	A12220-00	Cable, S200, AKM-33	2
22	A10796-00	Bulkhead Connector, 4-Pin, Amphenol	4
23	A10626-00	Cable Gland, 4-Port	1
24	22-1045	Flow Sensor Cable Assembly	1
25	41-FBH-1000	1/4" ODT Bulkhead	"C"
26	41-FBH-1001	3/8" ODT Bulkhead	"C"
27	A10974-00	26 Socket Bulkhead Assembly	1
28	A12268-00	Motor Hold Module	1

\* Used only if the optional Color Change Sequencer is installed.

\*\* Used only if the optional Color Change Sequencer is not installed.





**NOTES**

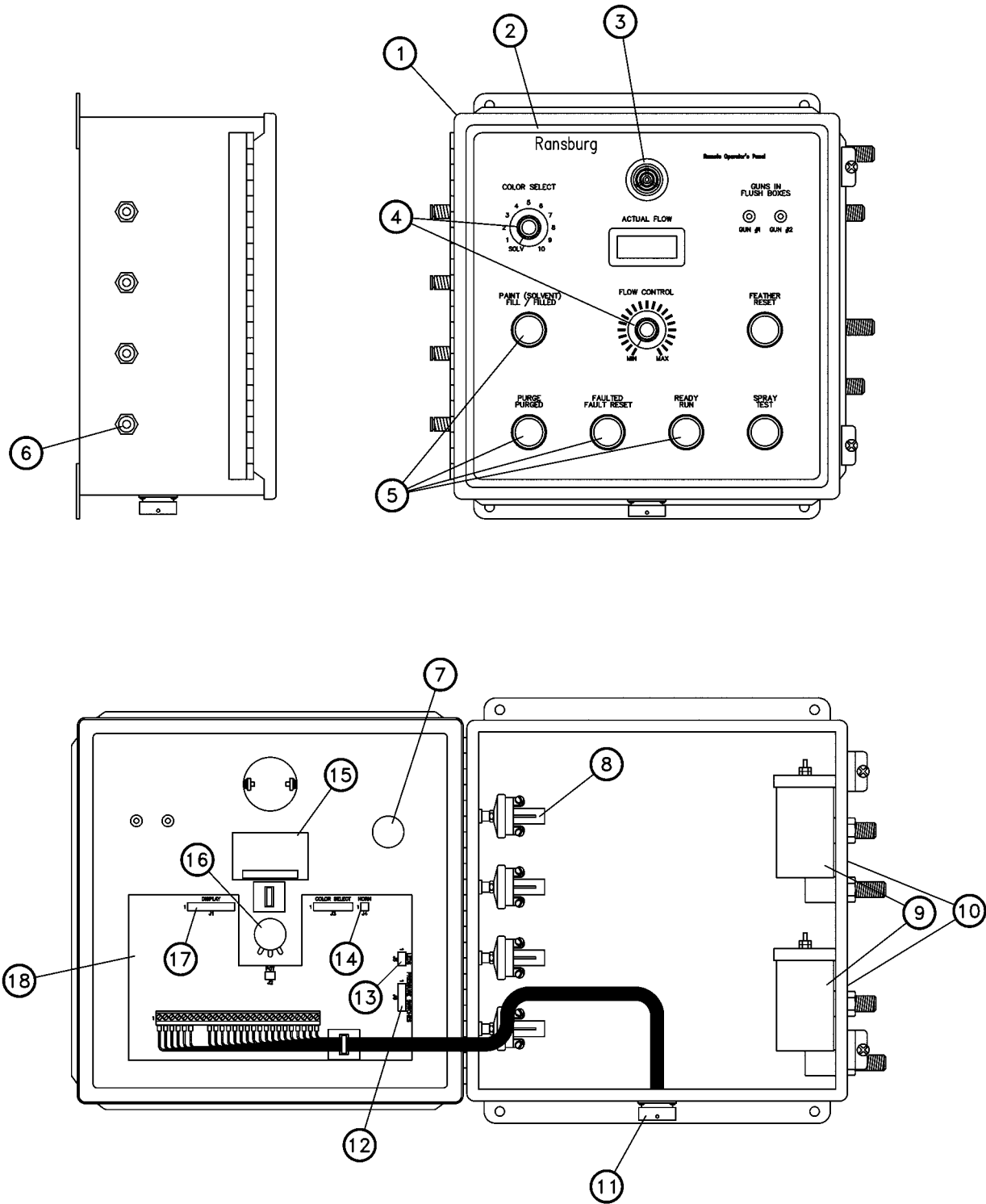

**Figure 7: Remote Operator's Panel**

<b>REMOTE OPERATOR'S PANEL - PARTS LIST (Figure 7)</b>			
<b>Item #</b>	<b>Part #</b>	<b>Description</b>	<b>Qty</b>
1	A10794-00	Enclosure Details, RCS-2 Remote Operator's Panel	1
2	A11093-00	Faceplate Label, RCS-2 Remote Operator's Panel	1
3	LSME0024-00	Horn	1
4	SSH-409	Knob	2
5	A11108-00	24V AC/DC LED for Use In IDEC Panel Mount Lamps	4
6	LSF10002-00	1/4" ODT X 1/8" NPT(F) Bulkhead Union, Alkon	4
7	A11096-00	Color Select Rotary Switch Harness Assembly	1
8	25766-106	Pressure Switch Assembly, 15#	"A" *
9	13742-01	Air Flow Switch Assembly	"B" *
10	72143-01	In/Out Nameplate	"B" *
11	A11105-00	Bulkhead/Wire Assembly, RCS-2 Remote Operator's Panel	1
12	A11099-00	Wiring Harness Assembly, Pressure Switches, RCS-2 ROP	1
13	A11100-00	LED Wiring Harness Assembly, RCS-2 Remote Operator's Panel	1
14	A11110-00	Wiring, Harness Assembly, Horn	1
15	A11102-00	LCD Display for DynaPump Remote Operator's Panel	1
16	A11097-00	Potentiometer Harness Assembly, RCS-2 Remote Operator's Panel	1
17	A11098-00	Wiring Harness Assembly, LCD Display, RCS-2 ROP	1
18	A10909-00	PC Board Assembly, DynaPump Remote Operator's Panel	1

\* Refer to "Remote Operator's Panel Model Identification" for quantities.

## REMOTE OPERATOR'S PANEL MODEL IDENTIFICATION

When ordering, use A11095-AB as indicated below.

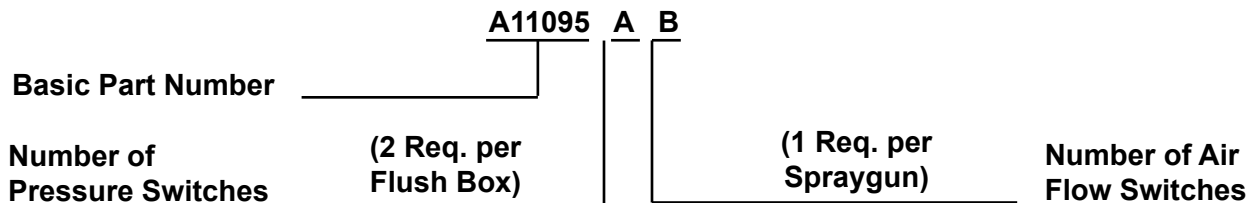

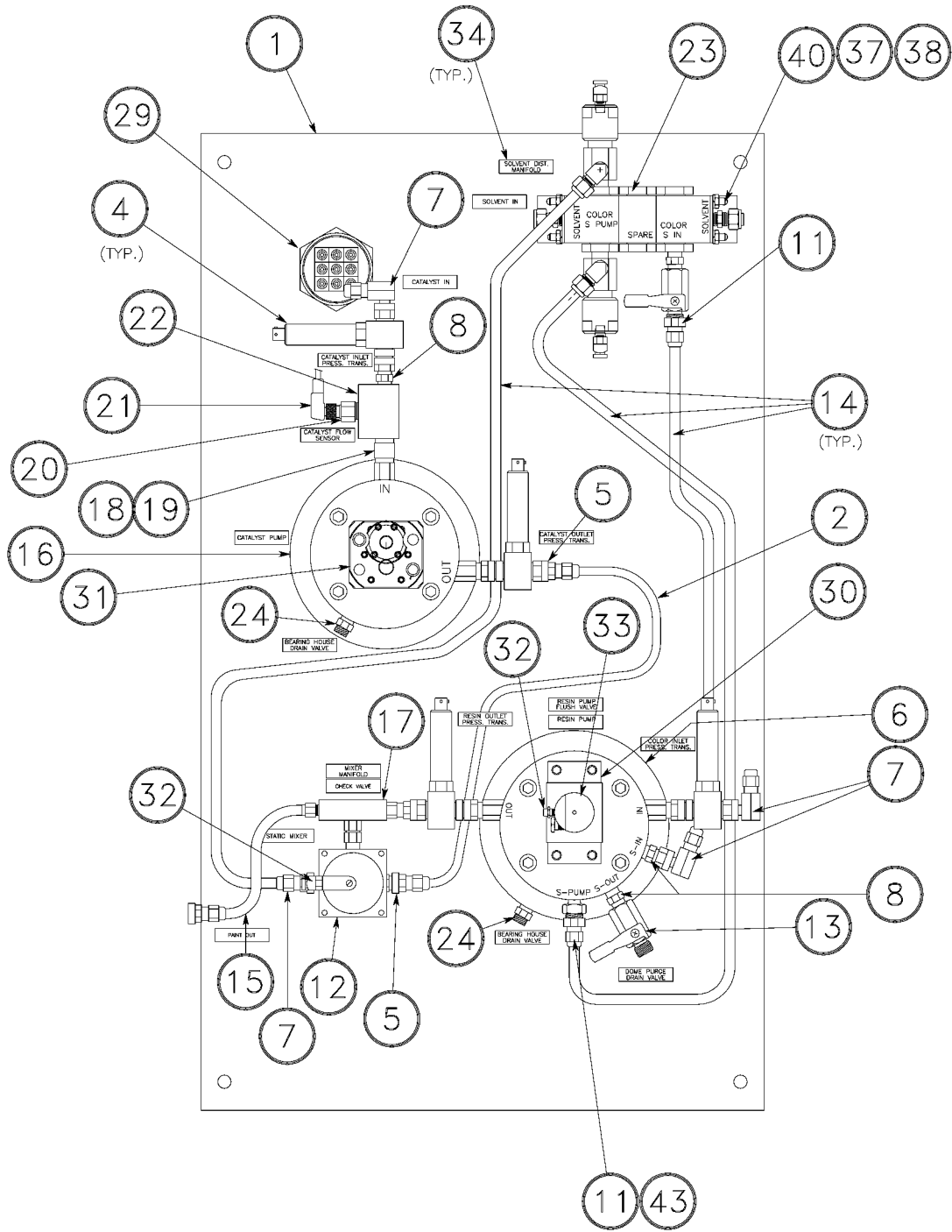

NOTE: ALL FLUID LINES ARE 3/8" ODT (SSP-5020)  
EXCEPT BETWEEN OUTLET OF CATALYST PUMP  
AND 3-WAY BALL VALVE, WHICH IS 5/16 ODT  
(76698-02).

Figure 8a: Fluid Panel Assembly (Front)

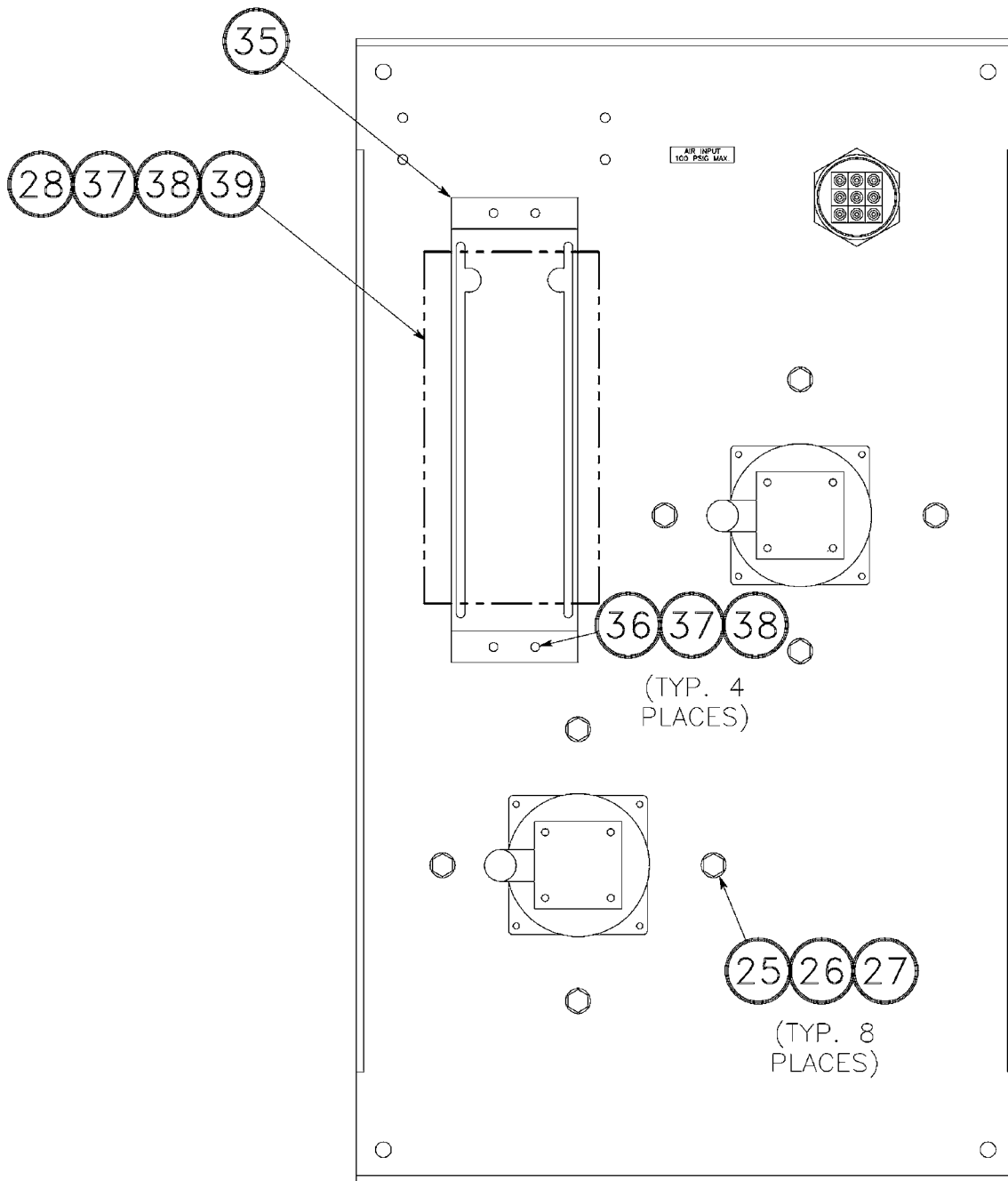
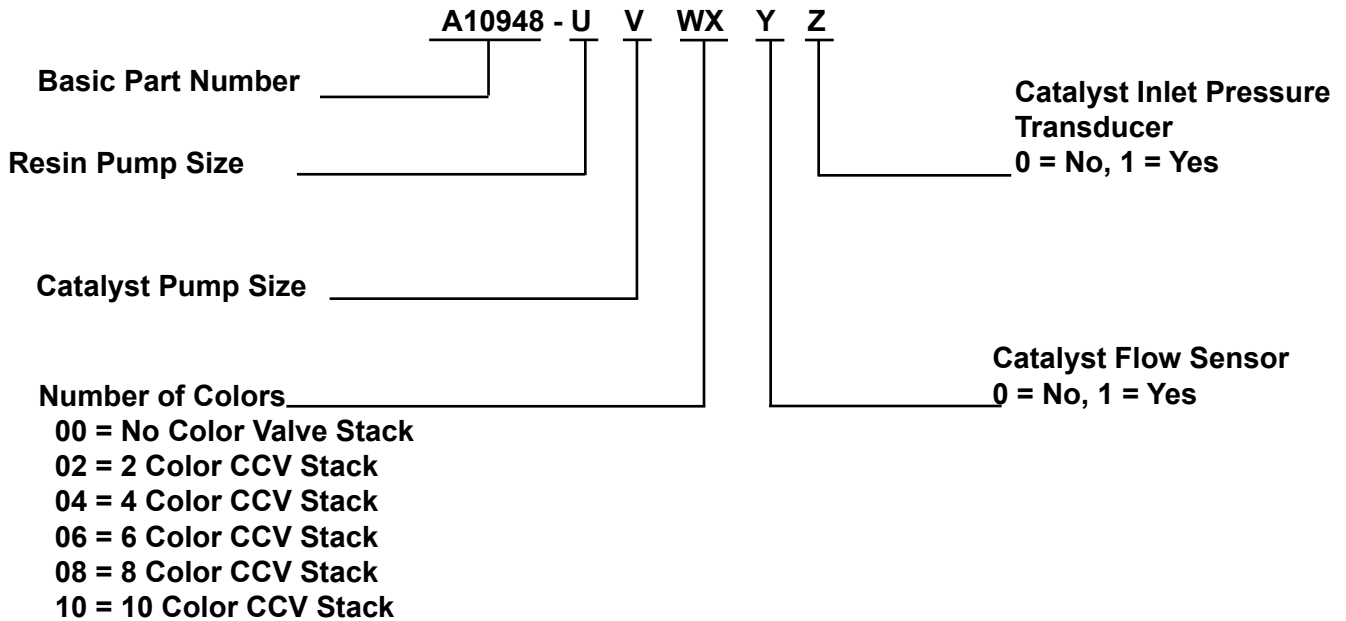

Figure 8b: Fluid Panel Assembly (Back)

<b>FLUID PANEL ASSEMBLY - PARTS LIST (Figures 8a &amp; 8b)</b>			
<b>Item #</b>	<b>Part #</b>	<b>Description</b>	<b>Qty</b>
1	A10949-00	Fluid Panel Details, RCS-2	1
2	76698-02	3/16" ID X 5/16" OD, Tubing	36"
3	A10528-00	Transducer Cable (Not Shown)	<b>Table Z - "R"</b>
4	22-910	Pressure Transducer Assembly W/Manifold & O-Ring	<b>Table Z - "S"</b>
5	77662-00	Connector, Swivel, 3/8" NPS X 3/16" ID, Hose	<b>Table Z - "T"</b>
6	22-963	Flushable Color Pump Manifold	1
7	77784-00	3/8" NPS(F) X 3/8" OD Tube, 90° Elbow	4
8	77639-00	1/8" NPT(M) X 3/8" NPS(M) Nipple	4
9	----	----	--
10	----	----	--
11	SSP-6443	3/8" ODT X 1/4" NPT(F) Fitting, Stainless Steel	1
12	77669-00	Pilot Operated Ball Valve	1
13	77671-00	Ball Valve, Stainless Steel	1
14	SSP-5020	3/8" OD Tubing	120"
15	22-451	Spiral Mixer	1
16	22-964	Hardener Pump Manifold	1
17	22-420	Mix Manifold W/Check Valve	1
18	77652-00	1/8" NPT(M) Stem	1
19	77659-00	3/8" NPS Nut	1
20	22-1043	Flow Sensor	<b>Table Y - "N"</b>
21	22-1045	Flow Sensor Cable (5 Conductor)	<b>Table Y - "O"</b>
22	22-1044	Manifold for Flow Sensor	<b>Table Y - "P"</b>
23	A11989-00	Solvent Manifold Assembly	1
24	77637-00	Nipple, 3/8" NPSM X 3/8" NPT DM	2
25	8156-24C	Hex Head Bolt, 5/16"-18 X 3/4" L (Cadium Plated)	8
26	SS-1524-CD	5/16" Stainless Steel Washer	8
27	7734-07	5/16" Lockwasher	10
28	A11793-32C	Carriage Bolt, 1/4"-20 X 1" L.	4
29	A10626-01	Cable Gland Assembly, 9 Position	1
30	<b>Table U - "B"</b>	<b>Table U - "C"</b>	<b>Table U - "A"</b>
31	<b>Table V - "E"</b>	<b>Table V - "F"</b>	<b>Table V - "D"</b>
32	41-FTP-1006	Fitting, Elbow, 5/32" ODT X 1/8" NPT(M)	4
33	22-337	Bypass Valve Assembly	1
34	A10976-00	Label Set, RCS-2 Fluid Panel	1
35	A10627-00	MCV Mounting Plate	<b>Table WX - "G"</b>
36	784074-20C	1/4"-20 X .625" L, Stainless Steel, HHCS	<b>Table WX - "H"</b>
37	77588-06	1/4" Lockwasher	<b>Table WX - "I"</b>
38	77485-00	1/4"-20 Hex Nut, Stainless Steel	<b>Table WX - "J"</b>
39	<b>Table WX - "L"</b>	<b>Table WX - "M"</b>	<b>Table WX - "K"</b>
40	78404-20C	1/4" - 20 X 5/8" L. Stainless Steel, HHCS	4
41	----	----	--
42	----	----	--
43	22-280-1	Check Valve, Stainless Steel	1

## FLUID PANEL ASSEMBLY MODEL IDENTIFICATION

When ordering, use A10948-UVWXYZ as indicated by Tables U, V, W X, Y, and Z. For example:



**TABLE U - RESIN (FLUSHABLE) PUMPS**

No.	"A"	"B"	Description	"C"		Grooved
				Size	Material	
0	--	--	No Pump Included	--	--	--
1	1	77844-01	Pump Kit, RCS	3.5 CC/REV	M2 Tool Steel	No
2	1	77844-08	Pump, RCS	3.5 CC/REV	M2 Tool Steel	Yes
3	1	77844-09	Pump, RCS	3.5 CC/REV	Polyond	No
4	1	77844-10	Pump, RCS	3.5 CC/REV	Polyond	Yes
5	1	77844-02	Pump Kit, RCS	5.5 CC/REV	M2 Tool Steel	No
6	1	77844-11	Pump, RCS	5.5 CC/REV	M2 Tool Steel	Yes
7	1	77844-12	Pump, RCS	5.5 CC/REV	Polyond	No
8	1	77844-13	Pump, RCS	5.5 CC/REV	Polyond	Yes
9	1	77844-03	Pump Kit, RCS	10.0 CC/REV	M2 Tool Steel	No
A	1	77844-14	Pump, RCS	10.0 CC/REV	M2 Tool Steel	Yes
B	1	77844-15	Pump, RCS	10.0 CC/REV	Polyond	No

<b>TABLE V - CATALYST (NON-FLUSHABLE) PUMPS</b>						
No.	"D"	"E"	Description	"F"		Grooved
				Size	Material	
0	--	--	No Pump Included	--	--	--
1	1	77844-06	Pump Kit, RCS	0.297 CC/REV	M2 Tool Steel	No
2	1	77844-07	Pump Kit, RCS	0.297 CC/REV	M2 Tool Steel	Yes
3	1	77844-16	Pump, RCS	0.297 CC/REV	Stainless Steel	No
4	1	77844-17	Pump, RCS	0.584 CC/REV	M2 Tool Steel	No
5	1	77844-05	Pump Kit, RCS	1.752 CC/REV	M2 Tool Steel	No
6	1	77844-04	Pump Kit, RCS	2.92 CC/REV	M2 Tool Steel	No

<b>TABLE WX - COLOR VALVE STACK TABULATION</b>							
No.	"G"	"H"	"I"	"J"	"K"	"L"	"M"
00	0	0	0	0	0	--	No Color Valve Stack Installed
02	1	4	8	8	1	CCV-5102-111	2-Color CCV Stack Assembly W/Solvent - Air Push
04	1	4	8	8	1	CCV-5104-111	4-Color CCV Stack Assembly W/Solvent - Air Push
06	1	4	8	8	1	CCV-5106-111	6-Color CCV Stack Assembly W/Solvent - Air Push
08	1	4	8	8	1	CCV-5108-111	8-Color CCV Stack Assembly W/Solvent - Air Push
10	1	4	8	8	1	CCV-5110-111	10-Color CCV Stack Assembly W/Solvent - Air Push

<b>TABLE Y - CATALYST FLOW SENSOR TABULATION</b>				
No.	"N"	"O"	"P"	"Description"
0	0	0	2	No Flow Sensor
1	1	1	3	Flow Sensor Included

<b>TABLE Z - CATALYST INLET PRESSURE TRANSDUCER TABULATION</b>				
No.	"R"	"S"	"T"	"Description"
0	3	3 *	3 *	No Pressure Sensor
1	4	4	4	Pressure Sensor Included

\* If no catalyst pump is used, S = 2 and T = 2.



**NOTES**



<b>NON-FLUSHABLE PUMP/MANIFOLD ASSEMBLY - PARTS LIST (Figure 9)</b>			
<b>Item #</b>	<b>Part #</b>	<b>Description</b>	<b>Qty</b>
1	7959-34C	1/4"-20 X 1-1/16 L, SHCS	4
2	SS-1505-CD	Lock Washer, 1/4"	4
3	22-1047	Non-Explosion Proof Kollmorgan Motor	1
	22-547	Explosion Proof Kollmorgan Motor	2
	22-1047-2	Non-Explosion Proof Motor	2
4	7959-28C	1/4"-20 X 7/8" L, SHCS	2
5	SS-1505-CD	Lock Washer, 1/4"	2
6	22-878	Key	1
7	22-867	Gear	1
8	78178-00	Set Screw, 1/4"-28, Cup Pt.	1
9	78179-00	Pin, Spirol, 5/64" X 3/4"	1
10	22-868	Outer Pole Ring Assembly	1
11	7554-119	O-Ring	1
12	22-875	Bearing Housing	1
13	22-854	O-Ring	1
14	22-945	Coupling Housing Assembly	1
15	22-862	O-Ring	1
16	22-939	Jump Pole Ring Assembly	1
17	22-872	Manifold Assembly	1
18	22-332	3/8" NPS(M) X 3/4"-16, Stainless Steel, Adapter Fitting	2
19	22-333	O-Ring	2
20	22-379	O-Ring	1
21	9946-80C	3/8"-16 X 2-1/2" L, SHCS	4
22	*	Non-Flushable Pump	1
23	*	SHCS	4

\* These items differ based on desired pump size.

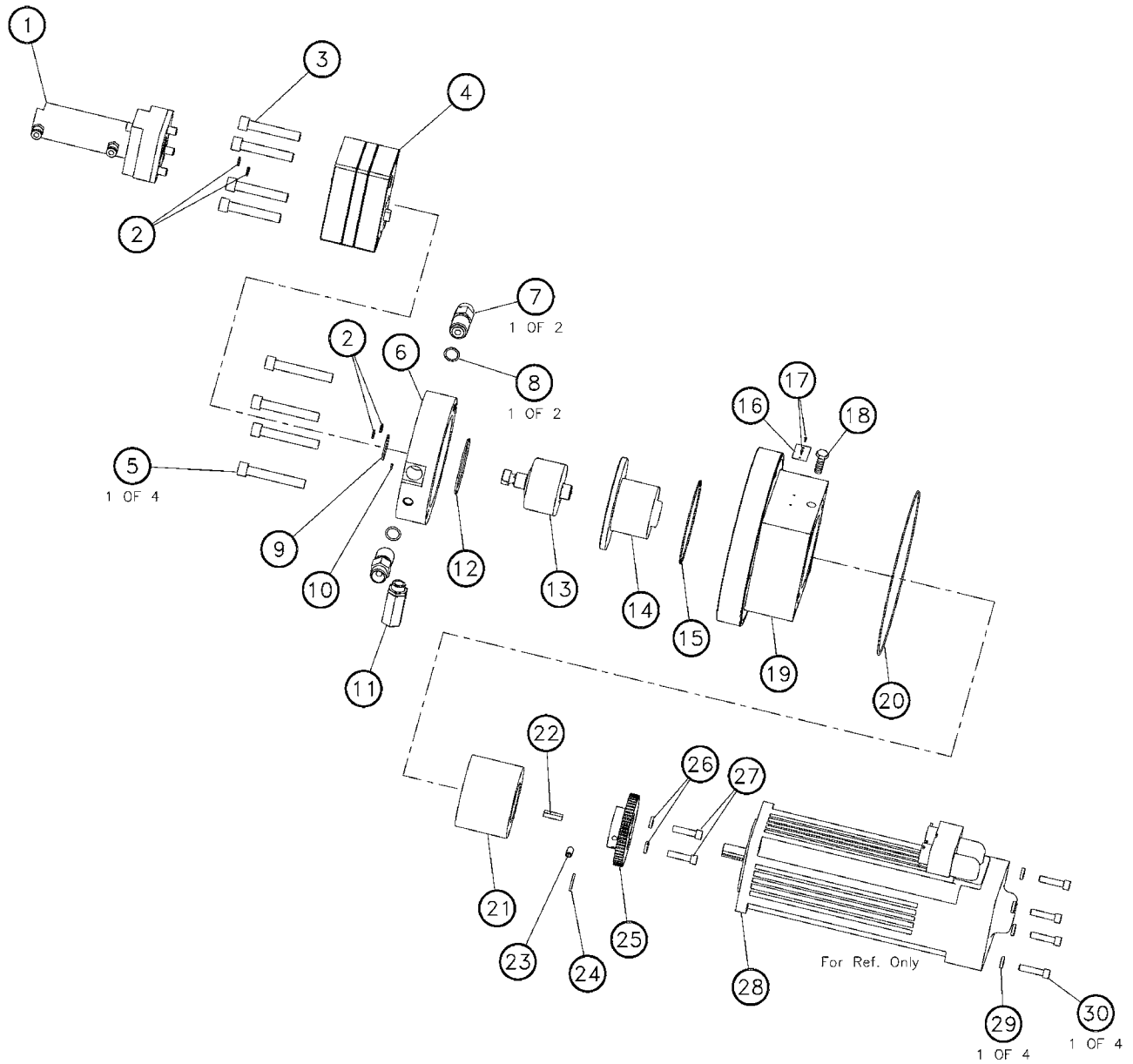

Figure 10: Flushable Pump/Manifold Assembly

<b>FLUSHABLE PUMP/MANIFOLD ASSEMBLY - PARTS LIST (Figure 10)</b>			
<b>Item #</b>	<b>Part #</b>	<b>Description</b>	<b>Qty</b>
1	22-337	Bypass Valve Assembly	1
2	22-336	O-Ring Seal	4
3	*	SHCS	4
4	*	Flushable Pump Assembly	1
5	9946-48C	3/8"-16 X 1.5" L, SHCS	4
6	22-935	Manifold Assembly	1
7	22-332	3/8" NPS(M) X 3/4"-16 Stainless Steel Adapter Fitting	2
8	22-333	11/16" X 0.070" O-Ring	2
9	20-5740	O-Ring	1
10	22-335	O-Ring	1
11	97-2271	Check Valve	1
12	22-862	O-Ring	1
13	22-939	Inner Pole Ring Assembly	1
14	22-945	Coupling Housing Assembly	1
15	22-854	O-Ring	1
16	77305-00	Name Plate W/Serial Number	1
17	78202-00	Drive Pin	2
18	78201-16	M8 X 1" X 16mm L, HHCS	1
19	22-875	Bearing Housing	1
20	7554-119	O-Ring	1
21	22-868	Outer Pole Ring Assembly	1
22	22-878	Key	1
23	78178-00	Set Screw, 1/4"-28, Cup Pt.	1
24	78179-00	Pin, Spirol, 5/64" X 3/4"	1
25	22-867	Gear	1
26	SS-1505-CD	Lock Washer, 1/4"	2
27	7959-28C	1/4"-20 X 7/8" L, SHCS	2
28	22-1047	Non-Explosion Proof Kollmorgan Motor	1
	22-547	Explosion Proof Kollmorgan Motor	1
	22-1047-2	Non-Explosion Proof Motor	1
29	SS-1505-CD	Lock Washer, 1/4"	4
30	7959-34C	1/4"-20 X 1-1/16" L, SHCS	4

\* These items differ based on desired pump size.

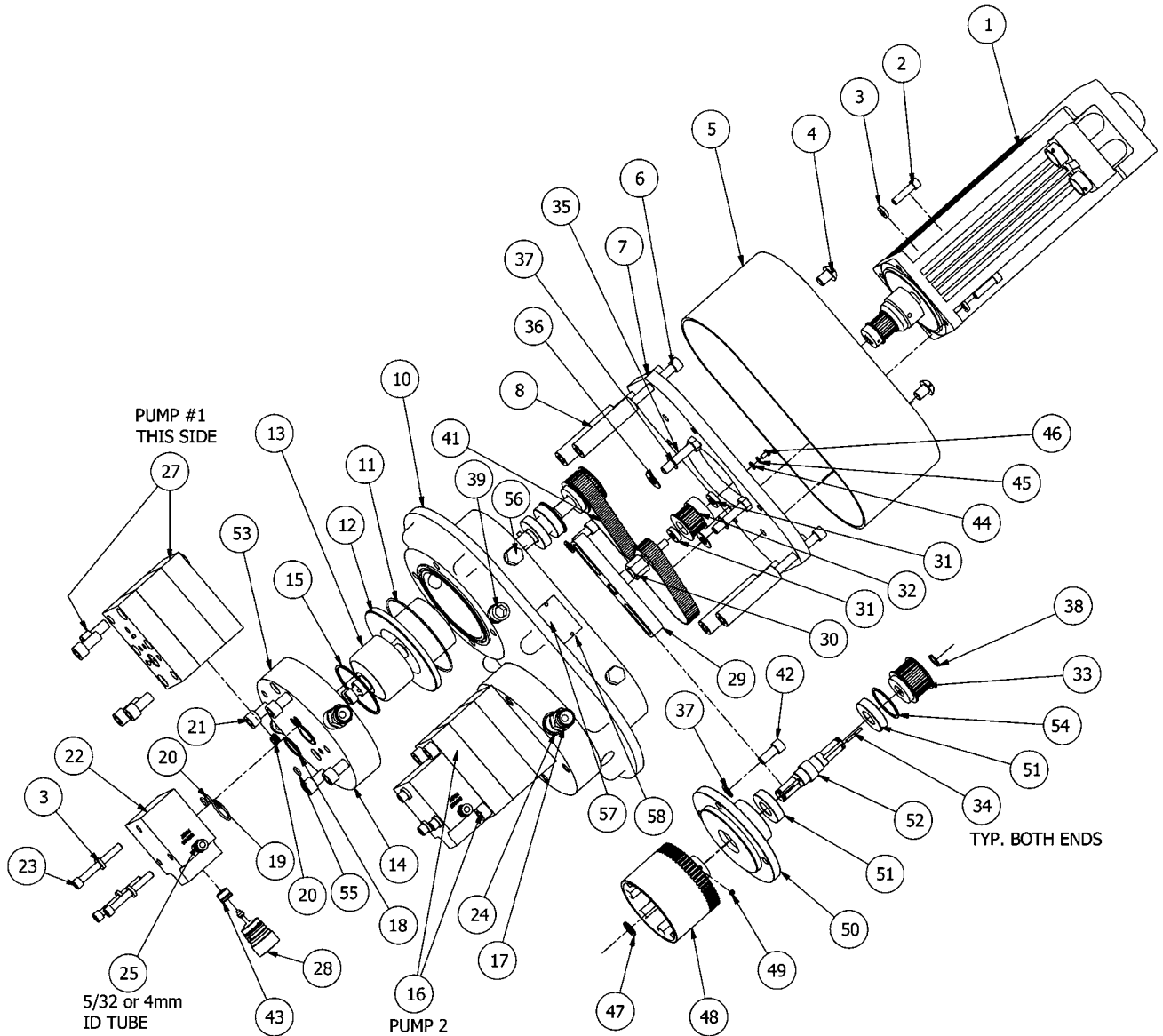

Figure 11: Dual-Headed Pump Assembly

<b>DUAL-HEADED PUMP ASSEMBLY - PARTS LIST (Figure 11)</b>			
<b>Item #</b>	<b>Part #</b>	<b>Description</b>	<b>Qty</b>
1	22-1302	Non-Explosion Proof Motor	1
	A11797-00	Explosion Proof Motor	1
2	7959-34C	1/4"-20 UNC X 1 1/16" L, SHCS (For Use With Non-Explosion Proof Motor)	4
	7421-24C	5/16"-18 UNC X 7/8" L, SHCS (For Use With Explosion Proof Motor)	4
3	SS-1515-CD	1/4" Lock Washer (For Use With Non-Explosion Proof Motor)	7
	7734-07	5/16" Lock Washer (For Use With Explosion Proof Motor)	4
4	20-6621	3/8"-16 X 1/2" L, Slotted, Round Head, Cap Screw	2
5	22-1309	Cover	1
6	20-6614	5/16"-18 UNC X 4" L, SHCS	4
7	22-1310	Motor Mounting Plate	1
8	22-1311	Motor Standoff	4
9	----	----	--
10	22-1303	Base, Machined	1
11	LSOR0005-05	O-Ring	2
12	22-954	Coupling Housing Assembly	2
13	22-939	Inner Magnetic Element	2
14	22-1332	Manifold Assembly (Flushable)	2
15	22-862	O-Ring, #2-141	2
16	77844-01	3.5 cc/rev Pump (With Fasteners)	1
	77844-02	5.5 cc/rev Pump (With Fasteners)	
	77844-03	10 cc/rev Pump (With Fasteners)	
17	22-332	Fluid Fitting, 3/8"-18 NPS(M) X 3/4"-16 UNF-2A(M)	4
18	13076-20	O-Ring, #2-020	2
19	EMFD-33	O-Ring, #2-018	2
20	22-336	Seal	8
21	9946-48C	3/8"-16 X 1 1/2" L, SHCS	8
22	A11796-00	MCV Bypass Block	2
23	76566-72C	1/4"-20 X 2" L, SHCS	6
24	22-333	Fluid Seal	4
25	78716-01	5/32" ODT (4mm) X 1/16" NPT(M), Fitting	2
26	----	----	--
27	77844-01 *	3.5 cc/rev Pump (With Fasteners)	1
	77844-02 *	5.5 cc/rev Pump (With Fasteners)	
	77844-03 *	10 cc/rev Pump (With Fasteners)	
28	7899-00	Valve Assembly	2
29	22-1313	Idler Plate	1
30	22-1315	Idler Standoff	1
31	22-139	Bearing, Idler Pulley	2
32	22-1317	Machined Idler Pulley	1
33	A11799 *	28 Tooth, Timing Belt Pulley	2
34	22-1316	Key, 1/8" X 1/8" X 3/4" Long	4
35	8156-48C	5/16"-18 X 1 1/2" L, HHCS	2
36	7486-07	5/16" X 3/4", Flat Washer	2
37	7734-07	5/16", Lock Washer	4
38	20-6613	Retaining Ring, 5105-37. Bowded External	2
39	78002-00	3/8" NPT Plug	4

(Continued On Next Page)

<b>DUAL-HEADED PUMP ASSEMBLY - PARTS LIST (Cont.) (Figure 11)</b>			
<b>Item #</b>	<b>Part #</b>	<b>Description</b>	<b>Qty</b>
40	----	----	--
41	22-1348	Timing Belt	1
42	8532-24C	5/16"-18 X 3/4" L, SHCS	2
43	77367-00	Valve Seat	2
44	20-3667	#6 Flat Washer	1
45	20-4332	#6 Lock Washer	1
46	20-6619	#6-32 X 1/4" L, Button Head Machine Screw	1
47	20-6612	Retaining Ring, 5101-50, Bowded External	2
48	22-1330	Outer Magnetic Element Assembly	2
49	20-6199	Set Screw, #10-32 X 3/16" Long	2
50	22-1328	Bearing Retainer	2
51	22-1327	Bearing	4
52	22-1326	Drive Shaft	2
53	20-3111	1/8" NPT, Pipe Plug	4
54	20-6664	Retaining Ring, 5101-37, Bowded External	2
55	22-335	Seal, Solvent Inlet Port	2
56	22-6494	Screw, M8 X 1, 16mm Long	4
57	77305-00	Name Plate	1
58	20-1671-1	Stick Screw	2

\* Ratio is controlled based on pump sizes (cc's/rev.) and the size of the 2 drive pulleys



**NOTES**

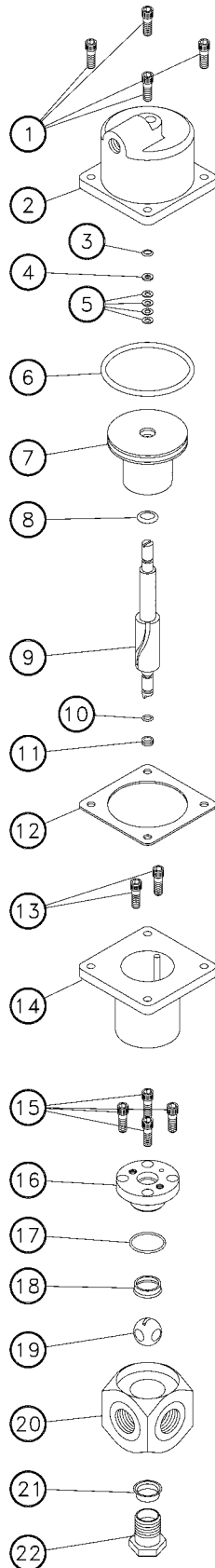

Figure 12: 77671-00 5-Way Ball Valve Assembly

**77671-00 5-WAY BALL VALVE ASSEMBLY - PARTS LIST**  
**(Figure 12)**

Item #	Part #	Description	Qty
1	20-317	#10-32 X 1/2", SHCS	4
2	78959-00	Housing	1
3	7554-03	O-Ring, 1/8" ID X 1/4" OD	1
4	72-1217	Bearing	1
5	20-4609	Belleville Washer	4
6	7554-36	O-Ring	1
7	78957-00	Piston	1
8	7554-09	O-Ring, 3/8" ID X 1/2" OD	1
9	78955-00	Stem	1
10	7554-07	O-Ring	1
11	20-3467	O-Ring	2
12	78958-00	Gasket	1
13	20-4677	#8-32 X 1/2" L, SHCS	2
14	78960-00	Housing	1
15	20-2652	#8-32 X 3/8" L, SHCS	4
16	78965-00	Retainer Plate	1
17	7554-122	O-Ring	1
18	79205-00	Seal, Upper	1
19	78951-00	Ball	1
20	78963-00	Body, 5-Way, Stainless Steel	1
21	79204-00	Lower Seal	1
22	78953-00	Plug	1

---

# TROUBLESHOOTING

---

## BLOCK DIAGRAMS

Over the next several pages are block diagrams of the following components of the RCS-2 control system:

- Main Control Console
- Motor Amplifier Panel
- Fluid Panel
- RCS Interface PC Board
- Channel PC Board

These drawings can be used to get an overall picture of function of each panel and control board and how they interact.

## RIBBON CABLE INTERCONNECT CHARTS

Following the block diagrams are charts showing how the ribbon cable assemblies connect the channel boards and the interface board to the breakout boards mounted on the back panel of the main control console. (The breakout boards are simply pass-through circuit boards that "breakout" the ribbon cable signals to screw terminals for easy field connections.) These charts detail what signals are passed to/from the channel boards and the interface board so that these signals can be easily traced for troubleshooting purposes.

## UMBILICAL CORD SIGNALS

Following the ribbon cable charts are charts of the umbilical cords (cable assemblies that run from the main control console to the motor amplifier panels). These charts outline what signals are carried by which pins, wires, and wire pairs. These charts can be used to aid in tracing down signal (or lack of signal) issues between the main control console and the motor amplifier panels.

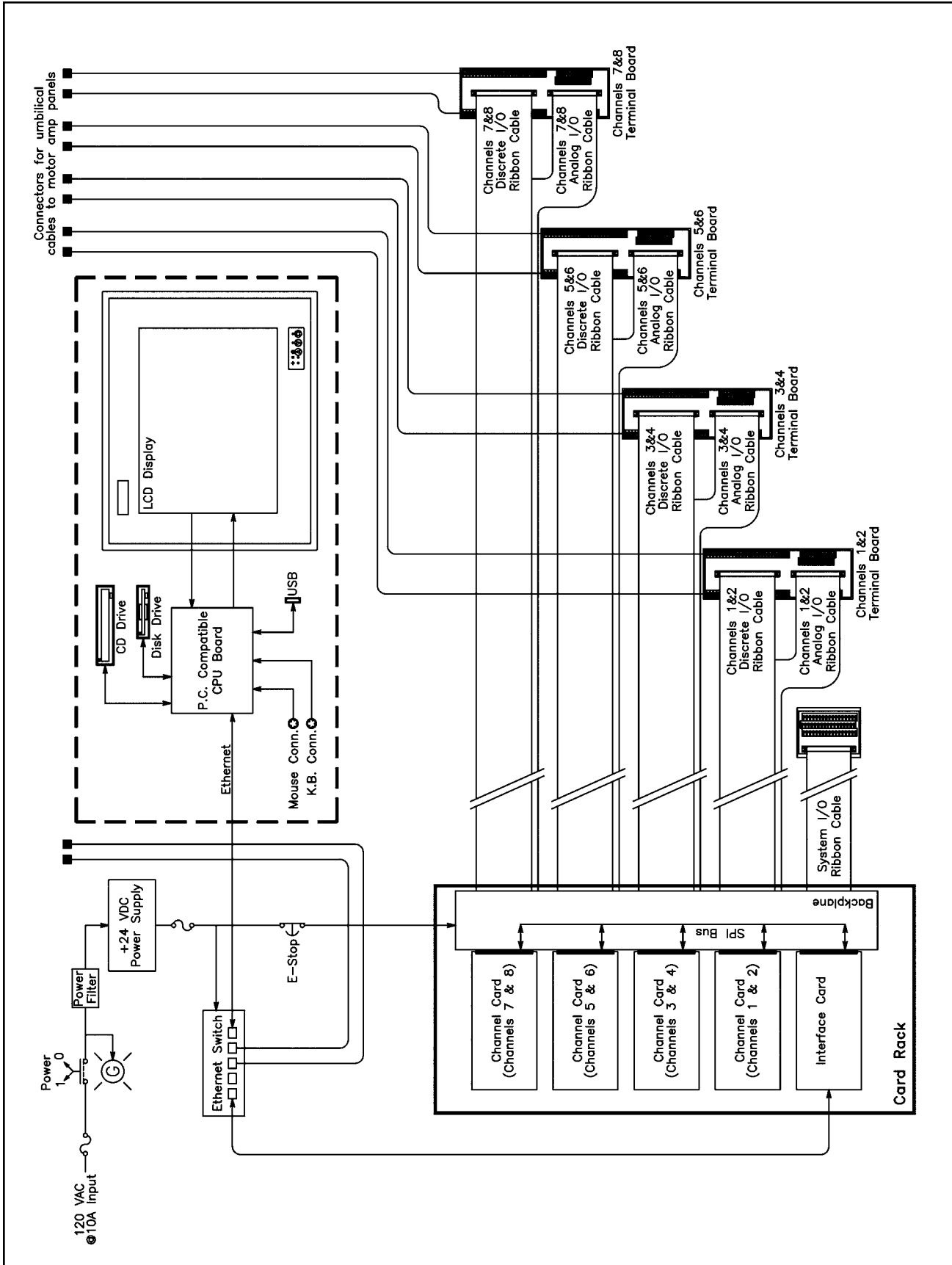

Figure 17: Control Console Block Diagram

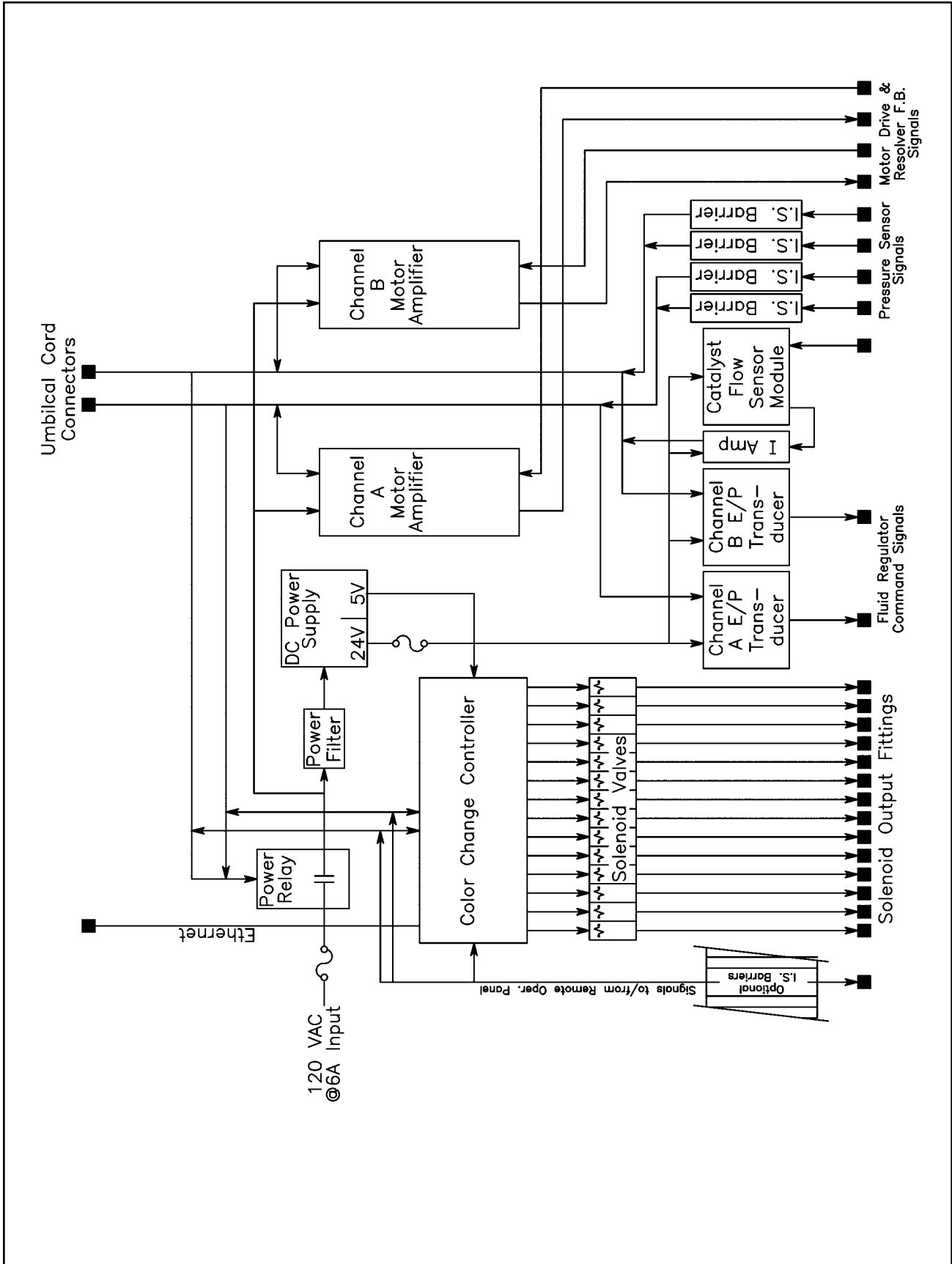

Figure 18: Motor Amplifier Block Diagram

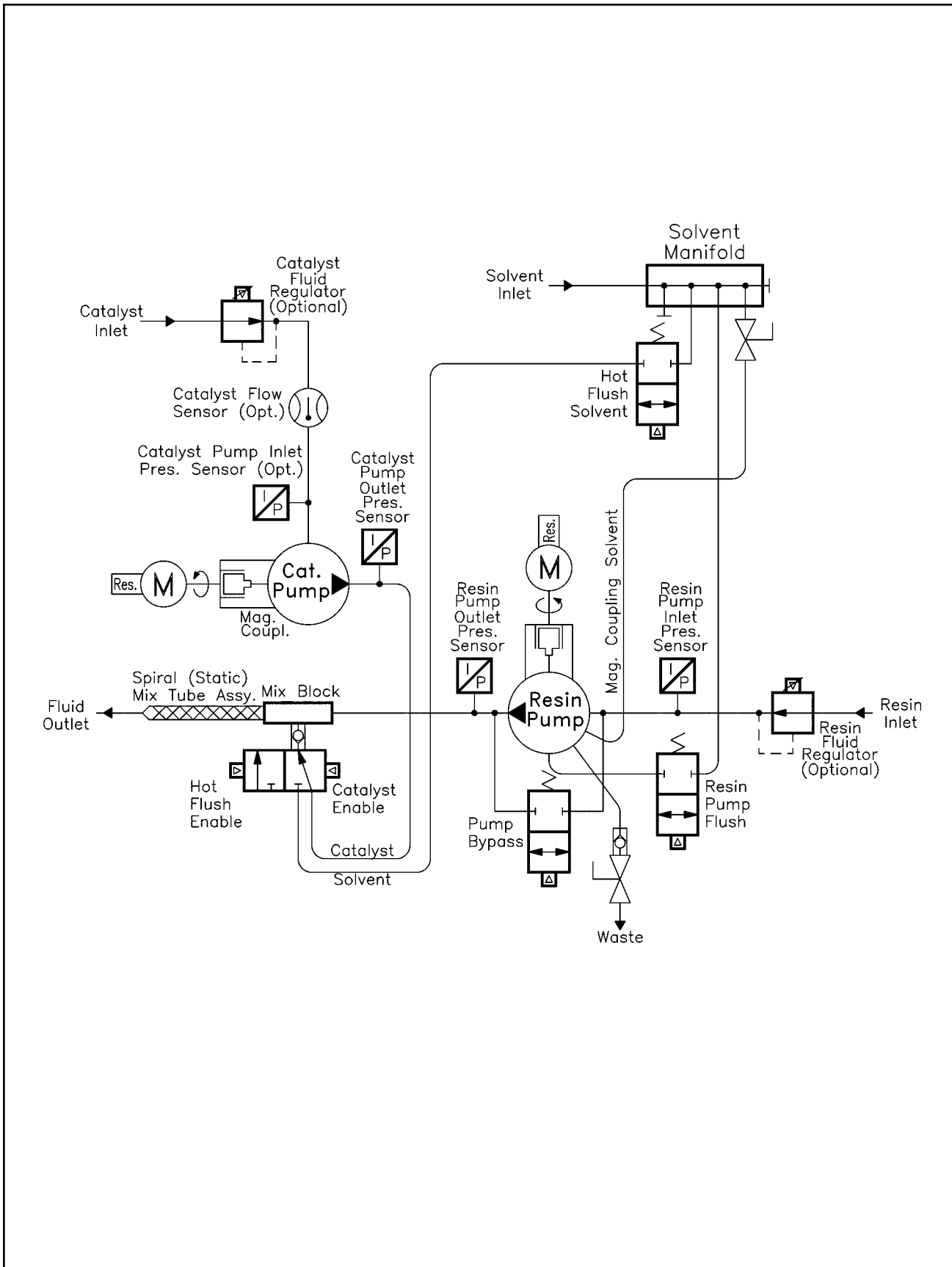

Figure 19: Fluid Panel Block Diagram

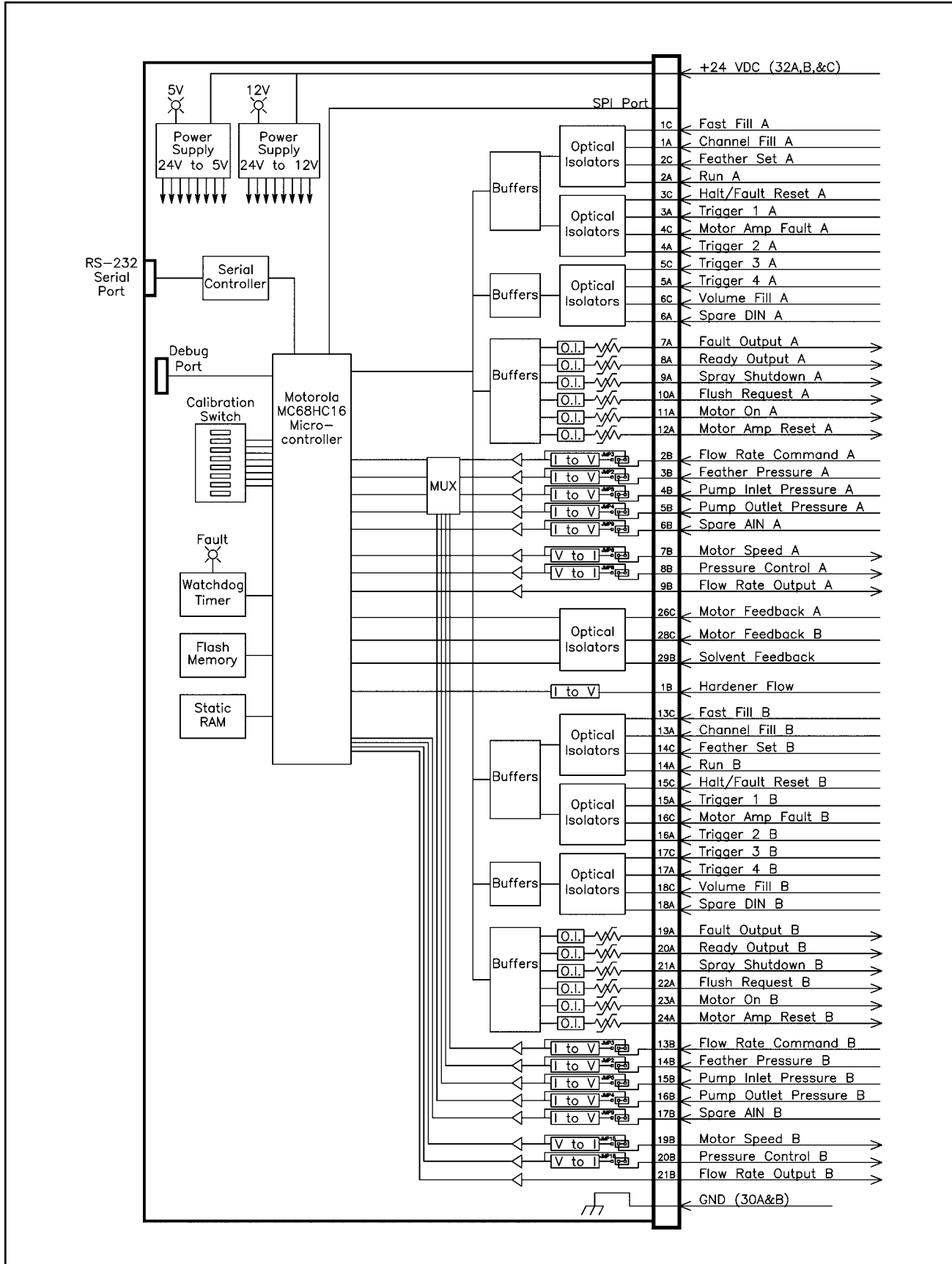

Figure 20: Channel Board Block Diagram





# INTERCONNECT CHART FOR CHANNELS 1, 3, 5, AND 7

Channel A Signals		Backplane Board (P/N: 78816)			64 Cond. Ribbon Cable (P/N: A10586)		Interconnect Board (P/N: A10554)	
		Channel Board (P/N: 78814) 96 Pin DIN Connector	96 Socket DIN Connector (Front Side)	96 Pin DIN Connector (Back Side)	96 Socket DIN Connector	64 Socket IDC Connector	(J1) 64 Pin IDC Connector	Screw Terminal
<u>Digital:</u>	<u>Input or Output</u>	<u>Connector</u>	<u>Connector</u>	<u>Connector</u>	<u>Connector</u>	<u>Connector</u>	<u>Connector</u>	<u>Terminal</u>
Fast Fill	Input	1C	1C	1C	1C	1	1	1A
Chan nel Fill	Input	1A	1A	1A	1A	2	2	2A
Feather Set	Input	2C	2C	2C	2C	3	3	3A
Run	Input	2A	2A	2A	2A	4	4	4A
Half/Fault Reset	Input	3C	3C	3C	3C	5	5	5A
Trigger 1	Input	3A	3A	3A	3A	6	6	6A
Motor Amp Fault	Input	4C	4C	4C	4C	7	7	7A
Trigger 2	Input	4A	4A	4A	4A	8	8	8A
Trigger 3	Input	5C	5C	5C	5C	9	9	9A
Trigger 4	Input	5A	5A	5A	5A	10	10	10A
Volume Fill	Input	6C	6C	6C	6C	11	11	11A
Pushout	Input	6A	6A	6A	6A	12	12	12A
Fault Output [hi]	Output	7C	7C	7C	7C	13	13	13A
Fault Output [low]	Output	7A	7A	7A	7A	14	14	14A
Ready Output [hi]	Output	8C	8C	8C	8C	15	15	15A
Ready Output [low]	Output	8A	8A	8A	8A	16	16	16A
Spray Shutdown [hi]	Output	9C	9C	9C	9C	17	17	17A
Spray Shutdown [low]	Output	9A	9A	9A	9A	18	18	18A
Flush Request [hi]	Output	10C	10C	10C	10C	19	19	19A
Flush Request [low]	Output	10A	10A	10A	10A	20	20	20A
Motor On [hi]	Output	11C	11C	11C	11C	21	21	21A
Motor On [low]	Output	11A	11A	11A	11A	22	22	22A
Motor Amp Reset [hi]	Output	12C	12C	12C	12C	23	23	23A
Motor Amp Reset [low]	Output	12A	12A	12A	12A	24	24	24A
Digital Ground	N/A	30A	30A	30A	30A	60	60	25A
Digital Ground	N/A	30B	30B	30B	30B			
+24 VDC	Output	32A	32A	32A	32A	64	64	26A
+24 VDC	Output	32B	32B	32B	32B			
+24 VDC	Output	32C	32C	32C	32C	63	63	26A

		Backplane Board (P/N: 78816)			50 Conductor Twisted Pair Ribbon Cable (P/N: A10587)		Interconnect Board (P/N: A10554)	
		Channel Board (P/N: 78814) 96 Pin DIN Connector	96 Socket DIN Connector (Front Side)	50 Pin IDC Connector (Back Side)	50 Socket DIN Connector	50 Socket IDC Connector	(J2) 50 Socket IDC Conn.	Screw Terminal
<u>Analog:</u>	<u>Input or Output</u>	<u>Connector</u>	<u>Connector</u>	<u>Connector</u>	<u>Connector</u>	<u>Connector</u>	<u>Terminal</u>	
Flow Rate Command	Input	2B	2B	3	3	3	3	28A
Analog Ground	N/A	30C	30C	4	4	4	4	A.G.
Feather Pressure	Input	3B	3B	5	5	5	5	29A
Analog Ground	N/A	30C	30C	6	6	6	6	A.G.
Pump Inlet Pressure	Input	4B	4B	7	7	7	7	30A
Analog Ground	N/A	30C	30C	8	8	8	8	A.G.
Pump Outlet Pressure	Input	5B	5B	9	9	9	9	31A
Analog Ground	N/A	30C	30C	10	10	10	10	A.G.
Spare Analog Input	Input	6B	6B	11	11	11	11	32A
Analog Ground	N/A	30C	30C	12	12	12	12	A.G.
Motor Speed	Output	7B	7B	13	13	13	13	33A
Analog Ground	N/A	30C	30C	14	14	14	14	A.G.
Pressure Control	Output	8B	8B	15	15	15	15	34A
Analog Ground	N/A	30C	30C	16	16	16	16	A.G.
Actual Flow Rate	Output	9B	9B	17	17	17	17	35A
Analog Ground	N/A	30C	30C	18	18	18	18	A.G.
<b>Pulse d:</b>								
Motor Feedback [A+]	Input	25C	25C	35	35	35	35	36A
Motor Feedback [A-]	Input	26C	26C	36	36	36	36	37A

# INTERCONNECT CHART FOR CHANNELS 2, 4, 6, AND 8

Channel B Signals		Channel Board (P/N: 78814)	Backplane Board (P/N: 78816)		64 Cond. Ribbon Cable (P/N: A10586)		Interconnect Board (P/N: A10554)	
Digital:	Input or Output	96 Pin DIN Connector	96 Socket DIN Connector (Front Side)	96 Pin DIN Connector (Back Side)	96 Socket DIN Connector	64 Socket IDC Connector	(J1) 64 Pin IDC Connector	Screw Terminal
	Fast Fill	13C	13C	13C	13C	25	25	1B
	Channel Fill	13A	13A	13A	13A	26	26	2B
	Feather Set	14C	14C	14C	14C	27	27	3B
	Run	14A	14A	14A	14A	28	28	4B
	Halt/Fault Reset	15C	15C	15C	15C	29	29	5B
	Trigger 1	15A	15A	15A	15A	30	30	6B
	Motor Amp Fault	16C	16C	16C	16C	31	31	7B
	Trigger 2	16A	16A	16A	16A	32	32	8B
	Trigger 3	17C	17C	17C	17C	33	33	9B
	Trigger 4	17A	17A	17A	17A	34	34	10B
	Volume Fill	18C	18C	18C	18C	35	35	11B
	Pushout	18A	18A	18A	18A	36	36	12B
	Fault Output [hi]	19C	19C	19C	19C	37	37	13B
	Fault Output [low]	19A	19A	19A	19A	38	38	14B
	Ready Output [hi]	20C	20C	20C	20C	39	39	15B
	Ready Output [low]	20A	20A	20A	20A	40	40	16B
	Spray Shutdown [hi]	21C	21C	21C	21C	41	41	17B
	Spray Shutdown [low]	21A	21A	21A	21A	42	42	18B
	Flush Request [hi]	22C	22C	22C	22C	43	43	19B
	Flush Request [low]	22A	22A	22A	22A	44	44	20B
	Motor On [hi]	23C	23C	23C	23C	45	45	21B
	Motor On [low]	23A	23A	23A	23A	46	46	22B
	Motor Amp Reset [hi]	24C	24C	24C	24C	47	47	23B
	Motor Amp Reset [low]	24A	24A	24A	24A	48	48	24B
	Digital Ground	N/A	30A	30A	30A	60	60	25B
	Digital Ground	N/A	30B	30B	30B			
	+24 VDC	Output	32A	32A	32A	64	64	26B
	+24 VDC	Output	32B	32B	32B			
	+24 VDC	Output	32C	32C	32C	63	63	26B

Channel B Signals		Channel Board (P/N: 78814)	Backplane Board (P/N: 78816)		50 Conductor Twisted Pair Ribbon Cable (P/N: A10587)		Interconnect Board (P/N: A10554)	
Analog:	Input or Output	96 Pin DIN Connector	96 Socket DIN Connector (Front Side)	50 Pin IDC Connector (Back Side)	50 Socket DIN Connector	50 Socket IDC Connector	(J2) 50 Socket IDC Conn.	Screw Terminal
	Hardener Flow	1B	1B	1	1	1	1	27B
	Analog Ground	N/A	30C	4	4	4	4	A.G.
	Flow Rate Command	13B	13B	19	19	19	19	28B
	Analog Ground	N/A	30C	20	20	20	20	A.G.
	Feather Pressure	14B	14B	21	21	21	21	29B
	Analog Ground	N/A	30C	22	22	22	22	A.G.
	Pump Inlet Pressure	15B	15B	23	23	23	23	30B
	Analog Ground	N/A	30C	24	24	24	24	A.G.
	Pump Outlet Pressure	16B	16B	25	25	25	25	31B
	Analog Ground	N/A	30C	26	26	26	26	A.G.
	Spare Analog Input	17B	17B	27	27	27	27	32B
	Analog Ground	N/A	30C	28	28	28	28	A.G.
	Motor Speed	Output	19B	29	29	29	29	33B
	Analog Ground	N/A	30C	30	30	30	30	A.G.
	Pressure Control	Output	20B	31	31	31	31	34B
	Analog Ground	N/A	30C	32	32	32	32	A.G.
	Actual Flow Rate	Output	21B	33	33	33	33	35B
	Analog Ground	N/A	30C	34	34	34	34	A.G.
	<b>Pulsed:</b>							
	Motor Feedback [B+]	Input	27C	37	37	37	37	36B
	Motor Feedback [B-]	Input	28C	38	38	38	38	37B
	Solvent [B+]	Input	29C	39	39	39	39	38B
	Solvent [B-]	Input	29B	40	40	40	40	39B

# INTERCONNECT CHART FOR SYSTEM I/O SIGNALS

System I/O Signals		Interface Board (P/N: 78818)	Backplane Board (P/N: 78816)		64 Cond. Ribbon Cable (P/N: A10586)		Interconnect Board (P/N: A11530)	
Digital:	Input or Output	96 Pin DIN Connector	96 Socket DIN Connector (Front Side)	96 Pin DIN Connector (Back Side)	96 Socket DIN Connector	64 Socket IDC Connector	(J1) 64 Pin IDC Connector	Screw Terminal
		Gun #1 Strobe	Input	1C	1C	1C	1C	1
Gun #2 Strobe	Input	2C	2C	2C	2C	3	3	TB1-2
Gun #3 Strobe	Input	3C	3C	3C	3C	5	5	TB1-3
Gun #4 Strobe	Input	4C	4C	4C	4C	7	7	TB1-4
Gun #5 Strobe	Input	1A	1A	1A	1A	2	2	TB1-5
Gun #6 Strobe	Input	2A	2A	2A	2A	4	4	TB1-6
Gun #7 Strobe	Input	3A	3A	3A	3A	6	6	TB1-7
Gun #8 Strobe	Input	4A	4A	4A	4A	8	8	TB1-8
System Fault Out [Hi]	Output	7C	7C	7C	7C	13	13	TB3-1
System Fault Out [Lo]	Output	7A	7A	7A	7A	14	14	TB4-1
System Pulse Out [Hi]	Output	8C	8C	8C	8C	15	15	TB3-2
System Pulse Out [Lo]	Output	8A	8A	8A	8A	16	16	TB4-2
Client Connected [Hi]	Output	9C	9C	9C	9C	17	17	TB3-3
Client Connected [Lo]	Output	9A	9A	9A	9A	18	18	TB4-3
Job Number 1	Input	13C	13C	13C	13C	25	25	TB5-1, TB6-1, & TB7-1
Job Number 2	Input	14C	14C	14C	14C	27	27	TB5-3, TB6-3, & TB7-3
Job Number 4	Input	15C	15C	15C	15C	29	29	TB5-5, TB6-5, & TB7-5
Job Number 8	Input	16C	16C	16C	16C	31	31	TB5-7, TB6-7, & TB7-7
Job Number 10	Input	17C	17C	17C	17C	33	33	TB5-9 TB6-9, & TB7-9
Job Number 20	Input	18C	18C	18C	18C	35	35	TB5-11, TB6-11, & TB7-11
Job Number 40	Input	13A	13A	13A	13A	26	26	TB5-2, TB6-2, & TB7-2
Job Number 80	Input	14A	14A	14A	14A	28	28	TB5-4, TB6-4, & TB7-4
Job Number 100	Input	15A	15A	15A	15A	30	30	TB5-6, TB6-6, & TB7-6
Spare Input 1	Input	16A	16A	16A	16A	32	32	TB5-8, TB6-8, & TB7-8
Spare Input 2	Input	17A	17A	17A	17A	34	34	TB5-10, TB6-10, & TB7-10
Spare Input 3	Input	18A	18A	18A	18A	36	36	TB5-12, TB6-12, & TB7-12

## ODD NUMBERED CHANNEL UMBILICAL CORD SIGNALS

Control Console (A10549) Wire Numbers				Umbilical Cord (A10487)			Signal Name	Motor Amp (A10776) Wire No.
Channel #1	Channel #3	Channel #5	Channel #7	Pin	Wire	Pair		
N/A	N/A	N/A	N/A	A	Black	Red/Blk	Catalyst Flow	1411
A.G.	A.G.	A.G.	A.G.	B	Red	Wht/Red	Inlet Pressure (-)	1542
A.G.	A.G.	A.G.	A.G.	C	Black	Wht/Blk	Outlet Pressure (-)	1562
1331	1331	1331	1331	D	Red	Blu/Red	+24 VDC	1041
1113	1113	1113	1113	E	Black	Grn/Blk	GND	1051
2053	2553	3053	3553	F	Blue	Blu/Blk	Trigger 2	7211
1113	1113	1113	1113	G	Black	Blu/Blk	GND	1051
2083	2583	3083	3583	H	Brown	Brn/Blk	Fault Out	7051
2303	2803	3303	3803	J	Black	Brn/Blk	Motor Feedback (-)	2092
2131	2631	3131	3631	K	Yellow	Yel/Blk	Motor Amp Reset [Hi]	N/C
2051	2551	3051	3551	L	Black	Yel/Blk	Motor Amp Fault	2061
2043	2543	3043	3543	M	Orn	Orn/Blk	Trigger 1	6631
2121	2621	3121	3621	N	Black	Orn/Blk	Motor On [Hi]	2081
A.G.	A.G.	A.G.	A.G.	P	Red	Yel/Red	Motor Speed (-)	2041
2103	2603	3103	3603	R	Red	Grn/Red	Spray Shutdown [Lo]	7071
2233	2273	3233	3273	S	Red	Red/Blk	Pressure Control	1231
2213	2713	3213	3713	T	White	Wht/Red	Inlet Pressure (+)	1532
2221	2721	3221	3721	U	White	Wht/Blk	Outlet Pressure (+)	1552
2241	2741	3241	3741	V	Green	Grn/Blk	Act. Flow Analog Out	7091
2041	2541	3041	3541	W	Red	Brn/Red	Halt/Fault Reset	6451
2021	2521	3021	3521	X	Brown	Brn/Red	Fast Fill	6471
2023	2523	3023	3523	Y	Red	Orn/Red	A Channel Fill	6491
2093	2593	3093	3593	Z	Orange	Orn/Red	Ready [Lo]	7111
2231	2731	3231	3731	a	Yellow	Yel/Red	Motor Speed (+)	2031
1113	1113	1113	1113	b	Drain	N/A	Shield	1051
2203	2703	3203	3703	g	Blue	Blu/Red	Flow Rate Command	7131
				N/C	Green	Grn/Red	Spare Wire	
				N/C	Blue	Blu/Grn	Spare Wire	
				N/C	Green	Blu/Grn	Spare Wire	

## EVEN NUMBERED CHANNEL UMBILICAL CORD SIGNALS

Control Console (A10549) Wire Numbers				Umbilical Cord (A10487)			Signal Name	Motor Amp (A10776) Wire No.
Channel #2	Channel #4	Channel #6	Channel #8	Pin	Wire	Pair		
2202	2702	3202	3702	A	Black	Red/Blk	Catalyst Flow	1411
A.G.	A.G.	A.G.	A.G.	B	Red	Wht/Red	Inlet Pressure (-)	1592
A.G.	A.G.	A.G.	A.G.	C	Black	Wht/Blk	Outlet Pressure (-)	1612
1331	1331	1331	1331	D	Red	Blu/Red	+24 VDC	1041
1113	1113	1113	1113	E	Black	Grn/Blk	GND	1051
----	----	----	----	F	Blue	Blu/Blk	Spare	----
1113	1113	1113	1113	G	Black	Blu/Blk	GND	1051
2033	2533	3033	3533	H	Brown	Brn/Blk	Run – Channel A	6431
2304	2804	3304	3804	J	Black	Brn/Blk	Motor Feedback (-)	2452
2132	2632	3132	3632	K	Yellow	Yel/Blk	Motor Amp Reset [Hi]	N/C
2052	2552	3052	3552	L	Black	Yel/Blk	Motor Amp Fault	2421
2031	2531	3031	3531	M	Orn	Orn/Blk	Feather Set-Channel A	7171
2122	2622	3122	3622	N	Black	Orn/Blk	Motor On [Hi]	2441
A.G.	A.G.	A.G.	A.G.	P	Red	Yel/Red	Motor Speed (-)	2401
4021	4031	4041	4051	R	Red	Grn/Red	Gun #1 Strobe	5091
2234	2734	3234	3734	S	Red	Red/Blk	Pressure Control	1271
2214	2714	3214	3714	T	White	Wht/Red	Inlet Pressure (+)	1582
2222	2722	3222	3737	U	White	Wht/Blk	Outlet Pressure (+)	1602
4141	4141	4141	4141	V	Green	Grn/Blk	Job #1 Bit	4611
4151	4151	4151	4151	W	Red	Brn/Red	Job #2 Bit	4631
4161	4161	4161	4161	X	Brown	Brn/Red	Job #4 Bit	4651
2024	2524	3024	3524	Y	Red	Orn/Red	B Channel Fill	6611
4171	4171	4171	4171	Z	Orange	Orn/Red	Job #8 Bit	4671
2232	2732	3232	3732	a	Yellow	Yel/Red	Motor Speed (+)	2391
1113	1113	1113	1113	b	Drain	N/A	Shield	1051
4181	4181	4181	4181	c	Blue	Blu/Red	Job #10 Bit	5071
				N/C	Green	Grn/Red	Spare Wire	
				N/C	Blue	Blu/Grn	Spare Wire	
				N/C	Green	Blu/Grn	Spare Wire	

**NOTES**

---

# WARRANTY POLICIES

---

## LIMITED WARRANTY

Ransburg will replace or repair without charge any part and/or equipment that falls within the specified time (see below) because of faulty workmanship or material, provided that the equipment has been used and maintained in accordance with Ransburg's written safety and operating instructions, and has been used under normal operating conditions. Normal wear items are excluded.

### **THE USE OF OTHER THAN RANSBURG APPROVED PARTS, VOID ALL WARRANTIES.**

**SPARE PARTS:** One hundred and eighty (180) days from date of purchase, except for rebuilt parts (any part number ending in "R") for which the warranty period is ninety (90) days.

**EQUIPMENT:** When purchased as a complete unit, (i.e., guns, power supplies, control units, etc.), is one (1) year from date of purchase. **WRAPPING THE APPLICATOR IN PLASTIC, SHRINK-WRAP, ETC., WILL VOID THIS WARRANTY.**

**RANSBURG'S ONLY OBLIGATION UNDER THIS WARRANTY IS TO REPLACE PARTS THAT HAVE FAILED BECAUSE OF FAULTY WORKMANSHIP OR MATERIALS. THERE ARE NO IMPLIED WARRANTIES NOR WARRANTIES OF EITHER MERCHANTABILITY OR FITNESS FOR A PARTICULAR PURPOSE. RANSBURG ASSUMES NO LIABILITY FOR INJURY, DAMAGE TO PROPERTY OR FOR CONSEQUENTIAL DAMAGES FOR LOSS OF GOODWILL OR PRODUCTION OR INCOME, WHICH RESULT FROM USE OR MISUSE OF THE EQUIPMENT BY PURCHASER OR OTHERS.**

### **EXCLUSIONS:**

If, in Ransburg's opinion the warranty item in question, or other items damaged by this part was improperly installed, operated or maintained, Ransburg will assume no responsibility for repair or replacement of the item or items. The purchaser, therefore will assume all responsibility for any cost of repair or replacement and service related costs if applicable.



## APPENDIX A: UPDATING THE FIRMWARE AND SOFTWARE ON THE RCS-2

### NOTE

► It is highly recommended that all parameter data be backed up to a USB memory stick prior to reprogramming any of the cards or replacing the user-interface software.

### Programming Cable

The cable used for programming both the channel card and the interface card for the RCS-2 has a Part Number A11892-00. It has two separate parts. One is simply a length of ribbon cable with a DB-9 male connector at one end and a DB-9 female connector at the other end. This cable is used to flash the memory on the channel card as well as accessing the serial port on the interface card for resetting job data and totals or modifying Ethernet configuration data. When flashing the memory on the interface card, the two cables should be used together. (See Figure 1)

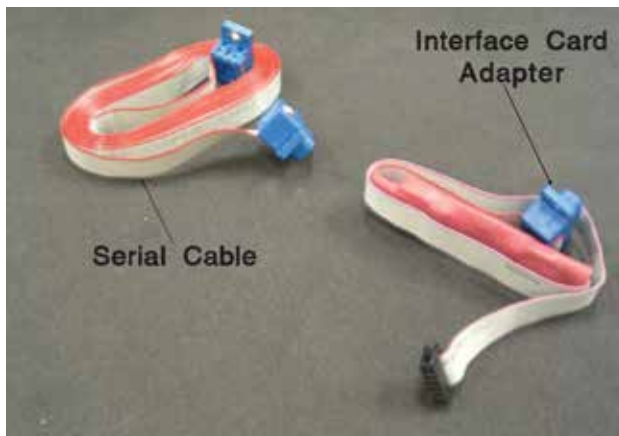

Figure 1: A11892-00 Programming Cable Set

### Programming the Channel Card (78814-01, 78814-02)

### NOTE

► Always remove the interface card (78818-01) from the rack prior to programming any channel card! Failing to do so will damage the interface card.

1. It is highly recommended that all connections and disconnections to programming ports on all PC boards be made with the power turned off to the RCS-2 rack. That being said, power down the rack prior to proceeding with this process.

Plug the RCS-2 Serial Cable (see Figure 1) into the serial port of a PC or Laptop and the serial port on the front of the channel card.

### NOTE

► DO NOT attach the Interface Card Adapter.



**Figure 2: Channel Card (78814-01, 78814-02)**

6. Select the "Find File to Download" button.
7. Select the drive and folder where the new firmware is located and then select the file.

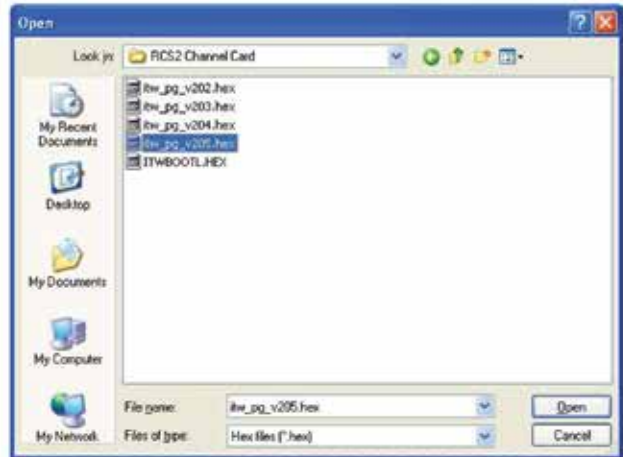

**Figure 3: Select Folder/File**

3. Turn power on to the rack.
4. On the PC, select the Bootloader program supplied to you by Ransburg. (If this software is not yet installed on the PC or Laptop, please install it at this time.)
5. Once the software is running, a screen that looks like Figure 3 should appear.

8. Select the Open button.
9. The downloader software screen should display the file you selected.



**Figure 3: Programming Software**



**Figure 4: Ready To Download**

10. Push the Download button. The program will download the new firmware to the flash memory on the card and show a status bar as it is doing so.

11. Once the program has completed downloading the entire code, the following screen will display.



**Figure 4: Download Completed**

12. Push the Done button to close the program.

13. Once the download process is complete, the power should be cycled on the rack to reset the channel card and allow it to reload its job parameters.

14. After power has been cycled, the faults on the RCS-2 may need to be cleared. On power-up, the interface card will automatically load the default job parameters to the channel card. If an alternate set of job data is required, follow the standard procedure to load the proper job data.

### Programming the Interface Card (78818-01)

1. Turn the power off to the rack.

2. Remove the Interface Card from the rack.

3. To download new software to the interface card requires the card to be put into programming mode. This is done by removing the jumper JMP7 from the board (see Figure 5). To prevent the jumper from being misplaced, it is recommended that you plug one side of the jumper into one of the 2 pins. This will hold the jumper while the module is being used in the programming mode.



**Programming Jumper JM7**

**Figure 5: Removal of Programming Jumper**

4. Reinsert the Interface card into the rack.

5. Insert the rectangular connector on the Interface Card Adapter Cable (Figure 5) into the port on the lower left side on the front face plate of the module. (This is the rectangular hole in the aluminum plate labeled PRG/DB.)



**Figure 6: Interface Card (78818-00)**

The cable should be inserted with the red marking on the cable in the up or top position. If the cable has two rectangular connectors on it, use the one labeled PROG.

6. The other end of the cable should be plugged into the serial port of the programming terminal (PC or Laptop). Use the Serial Cable extension, if necessary.

7. Apply power to the rack.

### NOTE

► The Reset lamp on the Interface Card will be flashing. This is normal.

8. Open the Rabbit Field Utility (RFU.exe) program on the PC or Laptop.



**Figure 9: Rabbit Field Utility**

9. Select the File pull down menu.

10. Select the Load Flash Image.

11. Select the file you wish to download.



**Figure 10: Choose File**

12. OK will send the file and the following messages will appear during the download process: Sending Coldloader, Sending Pilot Bios, Erasing Flash, and Sending Program.



**Figure 11: Programming Status Bar**

### Error Notes:

- a. If you receive an error such as coldloader.bin file or Flash Table file not found, select the Setup pulldown menu and then select File Locations. There are 3 fields that need to be filled in with the locations of those files.
- b. If you receive an error indicating that the Rabbit Processor was not found or an Error Reading or Writing Bits, make sure the rack is powered up, the jumper JMP7 is removed from the board, the connector is firmly connected to the programming port, and that the programming connector is inserted with Pin #1 in the up position.

13. Once programming is complete, power down the rack.

14. Remove the Rabbit programming cable from the card and programming PC or Laptop.

15. Remove the Interface Card from the Rack.
16. Replace jumper JMP7 in its original location.
17. Reinsert the Interface Card into the Rack.
18. Reinstall Channel Card or Cards if they were removed prior to software upgrade.
19. Power up the rack.
20. Errors may be indicated on the Error Log screen. They can be reset.
21. The new version of software can be validated by confirming the new software in the CONFIG SYSTEM (F1) touch screen and selecting VERSION INFO (F2).

### NOTE

► Jumper JMP7 can be installed on the board during the following setup procedures.

## Interface Card Configuration Procedure

1. Insert the Serial Cable into the RS-232 port on the front of the face plate of the Interface Card.

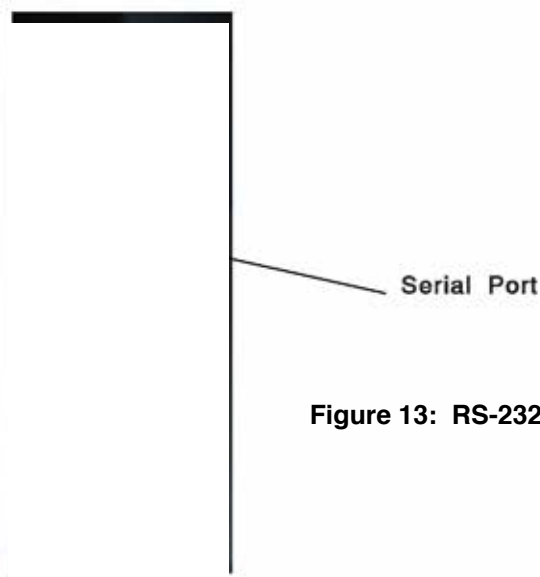

Figure 13: RS-232 Port

2. The other end of the Serial Cable is to be plugged into the serial port of the programming terminal (PC or Laptop).
3. Open the Hyper Terminal program from the Windows Start Menu (or any other similar terminal emulation program that works with the RS-232 serial port).
4. If HyperTerminal was not previously setup for use with the RCS-2 Interface Card, configure it with the following settings:
  - a. Baud Rate = 38400
  - b. Data Bits = 8
  - c. Parity = None
  - d. Stop Bits = 1
  - e. Flow Control = Xon/Xoff
  - f. Emulation = VT100
5. Power up on interface card and the Hyper Terminal will display the software version followed by some diagnostic information than the IP configuration information. It will then prompt the user to "Press any key within 3 seconds to enter console mode".
6. Hit the space bar (or any convenient key) to enter the console configurator. The unit will respond to the key press with a ">" prompt. (If repeated key hits fails to get a response from the unit and it continues on into normal operation mode, make sure you have Xon/Xoff setup as your flow control mode and emulation is setup as VT100.)

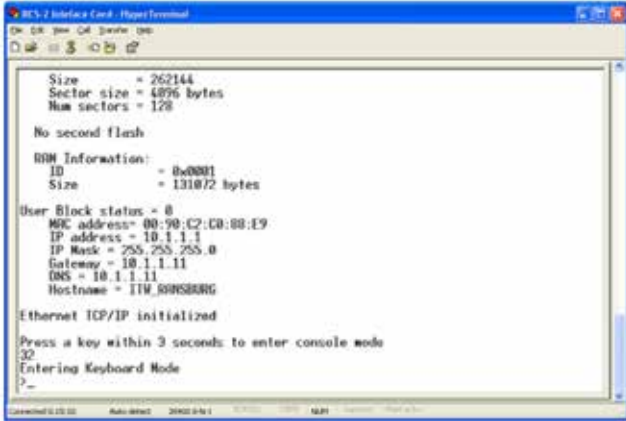

Figure 14: Interface Configuration Screen

**NOTE**

► There are 7 possible commands that can be executed from the console mode:

**HELP** - This command lists all the possible console commands.

**IPCONFIG** - Allows the user to change the IP configuration data.

**CLEARTOTALS** - Allows the user to clear all totalization data stored in memory.

**INITDATA** - Allows user to delete all job data stored in memory.

**PING** - Allows user to ping devices on the Ethernet network.

**RESET** - Resets the card (same as cycling power).

**RUN** - Takes the card out of console mode into normal operation mode.

7. To setup the IP address for the card, type IPCONFIG at the ">" prompt and follow the directions. (Make sure to save the new configuration to flash memory when prompted.)

8. It is highly recommended that all job data be reset every time new software has been loaded into the card as old data can become corrupted in the flashing process. If it is necessary to clear the Job data, type INITDATA and depress the enter key.

**NOTE**

► This clears all Job data from the battery backed memory on the interface card. Make sure this data has been backed up prior to doing Step 2.

9. Type "Run" and hit the enter key to restart the software running on the interface card.

10. Upon completion of the previous steps, the power should be turned off, the serial cables removed, and the power turned back on.

This should complete the interface card setup.

**User Interface Software (Touchscreen Software)**

1. The new software should be copied to a USB memory stick. Insert the memory stick into any one of the USB ports on the back of the touchscreen.

2. Shutdown the User-Interface software from the main screen of the RCS-2 (F12).

3. Using the Windows software functions, find your memory stick and copy the files supplied to you by Ransburg to the RCS-2 folder inside of the My Documents folder on the desktop. If prompted, confirm the overwriting of existing files with the same file names.

4. Remove the memory device from the RCS-2 main control PC.

5. Cycle power and verify that the user interface software reloads automatically on startup.



---

**APPENDIX B: ERROR LOG CHART**

---

<b>Error Name</b>	<b>Source</b>	<b>Description</b>	<b>Explanation and/or Possible Causes</b>
<b>Input Under Pressure</b>	Channel Card	Pump inlet pressure is below the Minimum Pressure value specified in the Channel Configuration	<ol style="list-style-type: none"> <li>1. No material available to pump inlet.</li> <li>2. Material supply pressure is too low.</li> <li>3. Loss of supply air to the E/P transducer that controls the pump inlet pressure.</li> <li>4. Loss of electrical supply or control signal to the E/P transducer that controls the pump inlet pressure.</li> <li>5. Failure of the E/P transducer that controls the pump inlet pressure.</li> <li>6. Failure of the pressure regulator that controls the pump inlet pressure.</li> <li>7. Failure of the pump inlet pressure sensor.</li> <li>8. Minimum Inlet Pressure value specified in the Channel Configuration is too high.</li> </ol>
<b>Input Over Pressure</b>	Channel Card	Pump inlet pressure is above the Maximum Pressure value specified in the Channel configuration.	<ol style="list-style-type: none"> <li>1. Failure of the E/P transducer that controls the pump inlet pressure.</li> <li>2. Failure of the pressure regulator that controls the pump inlet pressure.</li> <li>3. Maximum Inlet Pressure value specified in the Channel Configuration is too low.</li> </ol>
<b>Output Under Pressure</b>	Channel Card	Pump outlet pressure is below the Minimum Pressure value specified in the Channel Configuration	<ol style="list-style-type: none"> <li>1. Pump is not turning.</li> <li>2. Material is not available at pump inlet.</li> <li>3. Failure of pump outlet pressure sensor.</li> <li>4. Minimum Outlet Pressure value specified in the Channel Configuration is too high.</li> </ol>
<b>Output Over Pressure</b>	Channel Card	Pump outlet pressure is above the Maximum Pressure value specified in the Channel Configuration	<ol style="list-style-type: none"> <li>1. Restriction in the fluid line.</li> <li>2. For Automatic guns, failure of applicator trigger valve.</li> <li>3. Maximum Outlet pressure value specified in the Channel Configuration is too low.</li> </ol>
<b>Flow Rate Out of Tolerance</b>	Channel Card	The difference between the commanded flow rate (RPM) of the pump and the actual flow rate measured from the feedback signal exceeds +/- 2 times the Flow Rate/ Ratio Tolerance Percentage value specified in the Gun Configuration	<ol style="list-style-type: none"> <li>1. Loss of feedback signal from motor amplifier or flow meter.</li> <li>2. Incorrect Calibration Factor in Channel Configuration.</li> </ol>
<b>Hardener Flow Loss</b>	Channel Card	The electrical current from the Hardener Flow sensor is less than 1 milliamp	<ol style="list-style-type: none"> <li>1. There is no hardener flow due to the pump not operating or an obstruction in the hardener fluid line.</li> <li>2. Electrical connection problems.</li> <li>3. Failure of Hardener Flow sensor.</li> </ol>

**APPENDIX B: ERROR LOG CHART (Continued)**

<b>Error Name</b>	<b>Source</b>	<b>Description</b>	<b>Explanation and/or Possible Causes</b>
<b>Pressure Pot Empty</b>	<b>Channel Card</b>	The system has determined the pressure pot is empty for the respective channel	<ol style="list-style-type: none"> <li>1. The value entered for the pressure pot Capacity in the Job Configuration is Incorrect.</li> <li>2. The operator neglected to reset the Pressure Pot. Capacity when it was last filled.</li> <li>3. Pressure Pot is empty.</li> </ol>
<b>Inlet Pressure Loss</b>	<b>Channel Card</b>	The electrical current from the Pump Inlet Pressure Sensor is less than 1 milliamp	<ol style="list-style-type: none"> <li>1. Electrical connection problems.</li> <li>2. Failure of Pump Inlet Pressure sensor.</li> </ol>
<b>Outlet Pressure Loss</b>	<b>Channel Card</b>	The electrical current from the Pump Outlet Pressure sensor is less than 1 milliamp	<ol style="list-style-type: none"> <li>1. Electrical connection problems.</li> <li>2. Failure of Pump Outlet Pressure sensor.</li> </ol>
<b>Analog Remote Loss</b>	<b>Channel Card</b>	The electrical current from the Remote Analog Setpoint source is less than 1 milliamp	<ol style="list-style-type: none"> <li>1. Electrical connection problems.</li> <li>2. The Remote Analog Setpoint source is configured for voltage instead of current loop.</li> </ol>
<b>Ratio Out of Tolerance</b>	<b>Channel Card</b>	The difference between the desired ratio and the actual ratio, expressed as a percentage error, exceeds the Flow Rate/Ratio Tolerance Percentage value specified in the Gun Configuration.	<ol style="list-style-type: none"> <li>1. Loss of feedback signal from motor amplifier or flow meter.</li> <li>2. Incorrect Calibration Factor in Channel Configuration.</li> <li>3. One or both channel is unable to deliver the correct flow rate due to restriction in the fluid line, lack of material.</li> </ol>
<b>Motor Amplifier Fault</b>	<b>Channel Card</b>	The motor amplifier has detected a fault condition.	<ol style="list-style-type: none"> <li>1. Reference the motor amplifier diagnostics to determine the cause of the fault.</li> </ol>
<b>Analog Feather Loss</b>	<b>Channel Card</b>	The electrical current from the Feather pressure sensor is less than 1 milliamp	<ol style="list-style-type: none"> <li>1. Electrical connection problems.</li> <li>2. Failure of Feather Pressure sensor.</li> </ol>
<b>Analog Spare Loss</b>	<b>Channel Card</b>	The electrical current from the Spare Analog Input sensor is less than 1 milliamp	<ol style="list-style-type: none"> <li>1. Electrical connection problems.</li> <li>2. Failure of Spare Analog input sensor.</li> </ol>
<b>Foldback Pressure Reached</b>	<b>Channel Card</b>	The Pump Outlet pressure has exceeded the Foldback Pressure value specified in the System Configuration	<ol style="list-style-type: none"> <li>1. This error is normal when operating in Fast Fill or Channel Fill mode.</li> <li>2. For Automatic guns, restriction in the fluid line.</li> <li>3. For Automatic guns, failure of applicator trigger valve.</li> </ol>



**APPENDIX B: ERROR LOG CHART (Continued)**

<b>Error Name</b>	<b>Source</b>	<b>Description</b>	<b>Explanation and/or Possible Causes</b>
<b>Pot Life Expired</b>	<b>Channel Card</b>	Mixed material in the applicator fluid line has remained beyond the Pot Life Time specified in the Job Configuration.	<ol style="list-style-type: none"> <li>1. Mixed material has remained in the applicator fluid line beyond the Pot Life Time specified in the Job Configuration.</li> <li>2. The Flow Rate Setpoint specified in the Job Configuration, or via the Remote Analog Setpoint, or via Remote I/O, is not high enough to move the Mixed Volume specified in the Gun Configuration during the Pot Life Time specified in the Job Configuration.</li> </ol>
<b>System Over Pressure</b>	<b>Channel Card</b>	Either the Pump Outlet or Inlet pressure exceeded the Over-Pressure Limit specified in the System Configuration.	<ol style="list-style-type: none"> <li>1. Failure of the E/P transducer that controls the pump inlet pressure.</li> <li>2. Failure of the pressure regulator that controls the pump inlet pressure.</li> <li>3. Restriction in the fluid line.</li> <li>4. For Automatic guns, failure of applicator trigger valve.</li> <li>5. Over-Pressure Limit value specified in the System Configuration is too low.</li> </ol>
<b>Channel Card Parameter Fault</b>	<b>Channel Card</b>	Invalid parameter entered in either the Channel or Job Configuration.	<ol style="list-style-type: none"> <li>1. Hardener No Flow value specified in the Slave Channel Configuration is less than 4.0 milliamps.</li> <li>2. Hardener Flow On value specified in the Slave Channel Configuration is greater than 20.0 milliamps.</li> <li>3. Hardener No Flow value specified in the Slave Channel Configuration is greater than Hardener Flow On value specified in the Slave Channel Configuration.</li> <li>4. Any Minimum Pressure or Maximum Pressure value specified in the Channel Configuration or Feather Pressure specified in the Job Configuration exceeds the Over Pressure Limit value specified in the System Configuration.</li> </ol>
<b>Channel Card SPI Fault</b>	<b>Channel Card</b>	No communication via the Serial Peripheral Interface (SPI) bus has occurred between the Interface Card and Channel Card for more than one second.	<ol style="list-style-type: none"> <li>1. Interface Card is no longer functioning.</li> <li>2. Failure of the mother board (backplane).</li> <li>3. A firmware bug is preventing service of the SPI bus communications.</li> </ol>
<b>Channel Card Internal Fault</b>	<b>Channel Card</b>	The timer interrupt service routine is unable to execute the required firmware logic in the time between time interrupts.	<ol style="list-style-type: none"> <li>1. A firmware bug is preventing completion of required logic in the time between timer interrupts.</li> </ol>
<b>Interface SPI Fault</b>	<b>Interface Card</b>	The Interface Card detected an error while attempting to communicate with a Channel Card via the Serial Peripheral Interface (SPI) bus.	<ol style="list-style-type: none"> <li>1. This error may occur when the system is first powered up and may be ignored.</li> </ol>

## APPENDIX C: MOTOR AMPLIFIER LED DISPLAY FAULT CODES (PART 1)

### GE FANUC AMPLIFIER

LED Display	Definition	Explanation and/or Possible Causes
<b>PF</b>	Power Failure	This display indicates that the 120 VAC power supply to the motor amplifier has been cycled (turned off and back on).
<b>LE</b>	Loss Enable	This display indicates that the enable signal to the motor amplifier from the RCS-2 channel card is low or disabled. (This is normal when the unit is in the Ready or Halted state.)
<b>FE</b>	Following Error	This display indicates that the motor amplifier has commanded the motor to turn at a certain speed but was unable to maintain that speed. This usually indicates a motor, pump, or magnetic coupling that is bound up and not able to turn freely.
<b>EI</b>	Excessive Command Increment	This indicates that the motor amplifier was commanded by the RCS-2 channel card to turn faster than the motor is capable of turning. This typically indicates that improper parameters have been programmed into the RCS-2. Verify parameters such as pump size, calibration factor, maximum pump speed, and maximum flow.
<b>FL</b>	Feedback Lost	This indicates that the motor amplifier is no longer receiving feedback from the resolver mounted inside of the motor enclosure. Check the two cables running from the back of the motor to the bottom of the motor amplifier panel and the cables inside of the motor amplifier panel running from the motor amplifier to the bottom of the panel.
<b>OV</b>	Motor Power Over Voltage	This indicates that the voltage being supplied to the motor amplifier is excessive. Check the AC power supply voltage to the motor amplifier panel.
<b>EC</b>	Motor Power Clamp Excessive Duty Cycle	
<b>OC</b>	Motor Over-Current Fault	This indicates that the motor amplifier has exceeded the allowable current limit for the motor. This usually indicates a motor, pump, or magnetic coupling that is bound up and not able to turn freely.
<b>MT</b>	Motor Over-Temperature Fault	This indicates that the motor is running excessively hot. Look for binding of the motor magnetic coupling, or pump.
<b>DT</b>	Drive Over-Temperature	This indicates that the driver circuitry in the motor amplifier has exceeded the allowable temperature for that circuitry. This could indicate a failure in the motor amplifier itself, a failure in the motor, or a bound motor, pump, or magnetic coupling.

## APPENDIX C: MOTOR AMPLIFIER LED DISPLAY FAULT CODES (PART 2)

### AMPLIFIER

Status LED Blink Code	Fault Description	Explanation and/or Possible Causes
ON	No faults, power stage Enabled	Normal operation.
OFF	Control power not applied or insufficient control power applied	Loose or open circuit wiring of control power input. Low input voltage to control power supply.
Fast Blink	No faults, power stage Disabled	Hardware or Software Enable inactive. To enable drive, apply hardware enable and set software enable.
1	Not Assigned	
2	Motor Over Temp  Motor temperature exceeds allowed limit	High ambient temperature at motor. Insufficient motor heat sinking from motor mounting. Operating above the motor's continuous current rating. Motor temperature sensor failure or not connected.
3	Drive Over/Under Temp  Temperature of drive heatsink/ chassis is outside of allowed limits	High or low drive ambient temperature. Restriction of cooling air due to insufficient space around unit. Operating above the drive's continuous current rating.
4	Drive I*t Too High The product of the drives output current multiplied by time has exceeded allowed limits.  If current foldback is enabled, the drive peak output current automatically reduces to 0.67% of <b>DIpeak</b> . If foldback is not enabled, the drive will fault.	Mechanically-jammed motor. Motion profile acceleration requires peak current for too long of a time duration. Machine load on the motor increased by friction. Wiring problem between drive and motor yielding improper motion. Motor commutation error. Drive under-sized for application, friction, or load.
5	Motor I*I*t Too High  Motor current amplitude squared multiplied by time has exceed allowed limits	Mechanically-jammed motor. Motion profile acceleration requires peak current for too long of a time duration. Machine load on the motor increased by friction. Motor commutation error. Motor under-sized for application, friction, or load.
6	Optional Battery low  Optional fault used to indicate SFD battery supply voltage is low	Battery low fault enabled and battery is not installed. SFD Battery back-up voltage is low.

**APPENDIX C: MOTOR AMPLIFIER LED DISPLAY FAULT CODES (PART 2)**  
**(Continued)**

**AMPLIFIER**

Status LED Blink Code	Fault Description	Explanation and/or Possible Causes
7	Bus Over Voltage - Self Resetting  The BUS voltage has exceeded the upper threshold limit	AC Line voltage (AC unit) or DC bus power supply voltage (DC unit) is too high. Regenerative energy during deceleration is causing the BUS to rise: On AC Drives add regen resistor. On S200 DC input drives external BUS capacitor is too small; add capacitance.
8	Bus Under Voltage - Self Resetting  S200 DC drive fault only  BUS voltage is below specified 20 VDC minimum	On S200 DC input drives: BUS voltage is too low. BUS voltage is pulled down during high acceleration or loading. External BUS capacitor is too small.
9	Motor I-I or I-n Short  Line-to-Line, Line-to-Neutral, or Line-to-PE short on the motor output causing an instantaneous over current	Motor power wiring short circuit - line-to-ground/neutral. Motor cable short line-to-line. Motor power cable length exceeds the data sheet specification causing excessive motor line-to-earth ground/neutral capacitance. Internal motor winding short circuit. Motor L too small. <b>KIP</b> set too large.
10	Output Over Current	Insufficient motor inductance <b>KIP</b> or <b>KII</b> improperly set causing excessive output current overshoots.
11	Hall Fault  Valid only when drive is set to 6 Step (Hall feedback) operation	Invalid configuration. Motor overspeed. Invalid hall state. Invalid hall transition.
12	SFD Configuration Error	SFD UART error during SFD initialization. Bad motor data check sum. The drive will attempt to initialize the SFD up to 4 times. If it fails, this error is reported.
13	J3 FB +5V Short  Excessive current drain on SFD +5 supply output	Excessive loading on SFD +5 supply. Short in the feedback cable on SFD +5 (J3-1) to ground.
14	SFD Motor Data Error  Motor data in SFD is outside drive limits or is inconsistent	Motor and Drive are not compatible. Auto setup calculation yielded a desired parameter value outside valid range. Incorrect/inconsistent motor data loaded into the SFD.

## APPENDIX C: MOTOR AMPLIFIER LED DISPLAY FAULT CODES (PART 2) (Continued)

### AMPLIFIER

Status LED Blink Code	Fault Description	Explanation and/or Possible Causes
15	SFD Sensor Failure	Internal SFD failure. Excessive electrical noise in the drive environment causing communications interference.
16	SFD UART Error	Internal SFD failure.
17	SFD Communication Error	Feedback cable not connected at the drive or at the motor. Feedback cable shield not connected. Defective feedback cable. Internal SFD failure. Excessive electrical noise in the drive environment causing communications interference.
18	Option Card Watch Dog Time Out	Communication error between option card and main board.
19	Position Error Too Large	Check <b>ExtFaults</b> : <b>ExtFaults</b> = Step size over flow means <b>GearOut/GearIn</b> is too large. <b>ExtFaults</b> = Position error over flow means that the following error, = <b>PosErr</b> , has exceeded $\pm 128$ revs. Check if the motor is stalling or if the commanded speed is higher than the motor can achieve at the present bus voltage.
20	Option Card Fault	Check <b>ExtFaults</b> : If <b>ExtFaults</b> is <b>AuxFBFault</b> , then the AusFB device is in error. Check the AuxFB faults: <b>AuxFBEnDatFlt</b> , <b>AuxFBPTCFit</b> , or <b>AuxFBSCDFit</b> . Check to make sure the the drive is set up for the correct feedback device and that the device is functioning correctly. If <b>ExtFaults</b> is "No Extended Fault", then this was a fault induced by the controller, such as <b>SynqLost</b> .

## APPENDIX D: CALIBRATING THE PRESSURE TRANSDUCERS (PART 1)

### Calibrating the 22-546 Transducer

#### Calibration Procedure:

1. Ensure that the pressure transducer (22-546) is tightened in the manifold to a torque specification of 42 -48 in•lbs<sup>2</sup>.
2. Connect the transducer using the calibration cable (22-1520) to a power supply and a digital ammeter as shown.
3. Set the ammeter to read current in the range of 0 to 20 mA.
4. Turn on the power supply.
5. Remove the screw cap covering the adjustment screw on the pressure transducer (if one is installed).
6. Adjust the potentiometer in the pressure transducer such the current reading on the ammeter is 4.05 mA.
7. Replace cap in adjustment potentiometer hole.
8. Turn off power supply and return pressure transducer to service.

If transducer will not adjust to approximately 4.05 mA, it should be replaced.

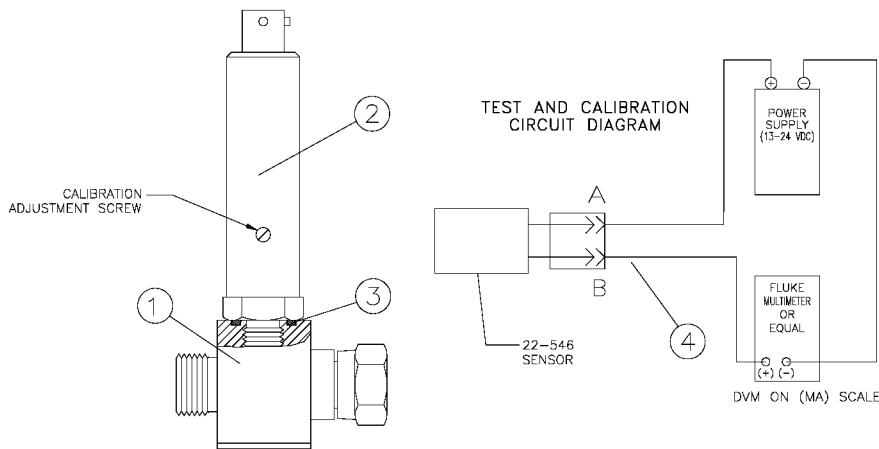

22-546 TRANSDUCER - PARTS LIST		
Item #	Part #	Description
1	22-911	Manifold Assembly
2	22-546	Pressure Transducer
3	7554-12	O-Ring
4	22-1520	Calibration Cable Assembly

## APPENDIX D: CALIBRATING THE PRESSURE TRANSDUCERS (PART 2)



To calibrate the pressure transducers (22-910) an electronic calibrator will be required (A10551).

The pressure transducer should be removed from the system to be calibrated or insure that all pressure has been released from the system. Do not remove the transducer from its manifold block as retightening of the sensor in the manifold block could effect the calibration.

Use the following steps to calibrate a transducer:

1. Prior to connecting anything to the calibrator (A10551), power up the unit by pressing the ON button on the calibrator.
2. You should be prompted to push the F1 button to continue.
3. The unit should then prompt you to connect the cable with the transducer connector on one end to the transducer and then to the left connector in the top of the calibrator.
4. You should then be prompted to connect the second cable to the mA input of a DVM and the other end to the right connector in the top of the calibrator.
5. You will then be prompted to set the DVM for current.

6. The calibrator will then advise that it is about to connect to the transducer and prompt you to push F1 to continue or F2 to quit.

7. The unit then checks its battery, then powers up the transducer, connects to the transducer, then downloads the necessary data from the transducer. The calibrator will display the serial number of the transducer and prompt you to push F1 to continue.

8. The calibrator will then display: ZERO ADJUSTMENT, with the options of F1 to quit, F2 to increase the value, and F3 to decrease the value.

Examine the value displayed on the DVM. Adjust it so it reads 4.01 to 4.03 mA.

### NOTE

- Each time you press the F2 or F3 buttons to increase or decrease the value, the calibrator must download that to the sensor so there is a slight delay. The unit will display: Writing... Done, F1 to continue. Repeat the process as many times as necessary to get the proper current displayed on the DVM.

Once the adjustments are completed, push the F1 key to exit. the unit powers down.

Disconnect the transducer from the calibrator and return it to service.

**APPENDIX E: RECOMMENDED SPARE PARTS**

<b>A10549 MAIN CONTROL CONSOLE - PARTS LIST</b>						
<b>Item #</b>	<b>Part #</b>	<b>Description</b>	<b>Quantity Being Purchased</b>			
			<b>1</b>	<b>2</b>	<b>4</b>	<b>8</b>
1	78835-01	24 VDC Power Supply	1	1	1	2
2	TR-SSEH-471	5 Amp (AGC) Fuse	5	5	5	10
3	TR-SSEH-472	10 Amp (AGC) Fuse	5	5	5	10
4	LSME0005-00	NO Contact Block	1	1	2	2
5	LSME0006-00	NC Contact Block	1	1	2	2
6	74300-00	120VAC Pilot Lamp	1	1	2	5
7	76948-00	On-Off Switch Actuator	0	0	1	1
8	77384-00	E-Stop Switch Actuator	0	0	1	1
9	A10530-00	Rack Assembly	0	0	0	1
10	A10705-02	Touch Screen PC	0	0	1	1
11	78818-00	Interface Board	1	1	2	2
12	77377-22	RIO Interface Board (Optional)	1	1	1	2
13	A10998-00	Ethernet Switch	0	0	1	1
14	78816-00	Backplane PC Board	0	0	0	1
15	A10554-00	Terminal Board (Channel I/O)	0	0	1	1
16	A11530-00	Terminal Board (System I/)	0	0	0	1
17	A10586-03	64 Conductor Ribbon Cable	0	0	1	1
18	A10587-02	50 Conductor (TP) Ribbon Cable	0	0	1	1
19	22-1108	Power Line Filter	0	1	1	2
20	--	Channel Board (Note: The quantities channel boards is dependent on the number of channels used and is, therefore, included with the Motor Amplifier Panel list.)				



## APPENDIX E: RECOMMENDED SPARE PARTS (Continued)

A10776 MOTOR AMPLIFIER PANEL - PARTS LIST						
Item #	Part #	Description	Quantity Being Purchased			
			1	2	4	8
1	78814-01/-02	Channel Board	1	1	2	4
2	A10783-01	Motor Drive Amplifier (GE Fanuc)	1	1	1	2
	A12219-01	Motor Drive Amplifier				
3	75337-06	24VDC Power Supply	1	1	1	2
4	SSS-7016	24VDC Relay	1	1	1	2
5	TR-SSEH-471	5 Amp (AGC) Fuse	5	5	5	10
6	TR-SSEH-472	10 Amp (AGC) Fuse	5	5	5	10
7	22-1050	Flow Switch Amplifier	0	0	1	1
8	22-1046	Flow Monitor Control Unit	0	0	1	1
9	22-1245	Zener Barrier for 4-20mA (Pres. Xducers)	1	1	1	2
10	73837-08	Zener Barrier for 24VDC (Rem. Oper. Panel)	1	1	1	2
11	78643-00	E to P Transducer	1	1	2	3
12	A10490-00	Tachometer Cable (GE Fanuc Amps)	1	1	1	2
13	A10491-00	Motor Drive Cable (GE Fanuc Amps))	1	1	1	2
14	A10528-00	Pressure Transducer Cable	1	1	2	4
15	22-1045	Catalyst Flow Sensor Cable	1	1	1	2
16	22-1108	Power Line Filter	0	1	1	2
17	A10785-01	Color Change Controller Brain (Opt.)	0	0	0	1
18	A10786-00	Color Change Controller Input Module (Opt.)	0	0	0	1
19	A10787-00	Color Change Controller Output Module (Opt.)	0	0	1	2
20	41-VSO-1005	Solenoid Valve (Opt.)	1	1	2	4
21	A12220-00	Motor Drive Cable	1	1	1	2

**APPENDIX E: RECOMMENDED SPARE PARTS  
(Continued)**

<b>A10948 FLUID PANEL - PARTS LIST</b>						
<b>Item #</b>	<b>Part #</b>	<b>Description</b>	<b>Quantity Being Purchased</b>			
			<b>1</b>	<b>2</b>	<b>4</b>	<b>8</b>
1	22-910	Pressure Transducer Assembly	1	1	2	4
2	22-556	Pilot Operated Bellows Valve	0	1	1	2
3	77669-00	Pilot Operated Ball Valve	1	1	1	2
4	77671-00	Manually Operated Ball Valve	1	1	2	4
5	22-451	Spiral Mixer	2	4	8	16
6	22-420	Mix Manifold W/Check Valve	1	1	2	4
7	22-1043	Catalyst Flow Sensor	0	0	1	1
8	22-1045	Catalyst Flow Sensor Cable	0	0	0	1
9	22-1044	Manifold for Flow Sensor	0	0	0	1
10	77844-XX	Resin Pump Assembly	0	1	1	1
11	77844-XX	Catalyst Pump Assembly	0	1	1	1
12	22-337	Bypass Valve Assembly	0	0	1	2
13	22-383	Lip Seal for Pump	0	0	1	2
14	97-2019	Diaphragm for Pump Bypass Valve	1	1	2	4
15	22-336	O-Ring Seals for Pump Bypass Valve and between Flushable Pump and Manifold	4	4	8	16
16	7554-119	O-Ring for Bearing Housing	2	2	4	8
17	22-854	O-Ring for Back Side of Magnetic Coupling Housing (Used on both style pumps.)	2	2	4	8
18	22-862	O-Ring for Front Side of Magnetic Coupling Housing (Used on both style pumps.)	2	2	4	8
19	22-333	O-Ring for Fluid Inlet and Outlet FittingsO-Ring used between Non-Flushable Pump and	4	4	8	16
20	22-379	Manifold	2	2	4	8
21	22-5740	O-Ring used between Non-Flushable Pump and Manifold	1	1	2	4
22	22-335	O-Ring used between Non-Flushable Pump and Manifold	1	1	2	4
23	22-947	Magnetic Coupling Housing Bushing	1	1	2	4
24	22-945	Magnetic Coupling Housing Assembly	0	0	1	1
25	22-939	Inner Pole Ring Assembly	0	0	1	1

## APPENDIX E: RECOMMENDED SPARE PARTS (Continued)

SEAL KITS, TOOLS, TUBING, ETC. - PARTS LIST						
Item #	Part #	Description	Quantity Being Purchased			
			1	2	4	8
1	22-1285	Color (Resin) Pump Seal Kit Includes: (1) 22-335, (2) 22-336, (1) 3076-20	1	2	4	8
2	22-1286	Hardener (Catalyst) Pump Seal Kit Includes: (1) 22-336, (1) 22-364, (1) 22-366, (1) 22-379	1	2	4	8
3	22-543	Hardener Seal Insertion Tool	1	1	1	2
4	22-542	Color Seal Insertion Tool	1	1	1	2
5	22-1033	Male Dowel Insertion Tool	1	1	1	2
6	22-1034	Female Dowel Insertion Tool	1	1	1	2
7	76698-00	3/16" IC X 5/16" OD Tubing	10'	10'	20'	50'
8	SSP-5020	3/8" OD Tubing	20'	20'	40'	100'
9	TR-SSEM-548	5/32" OD Polyethylene Tubing	50'	50'	50'	100'
10	77587-00	3/16" OD Polyethylene Tubing	50'	50'	50'	100'
11	9704-03	1/4" OD Polyethylene Tubing	50'	50'	50'	100'
12	H-2338	3/8" OD Polyethylene Tubing	50'	50'	50'	100'

A11095 REMOTE OPERATOR'S PANEL - PARTS LIST						
Item #	Part #	Description	Quantity Being Purchased			
			1	2	4	8
1	13742-01	Air Flow Switch	1	1	2	4
2	25766-106	Pressure Switch	1	1	1	2

APPENDIX F: SYSTEM LAYOUT

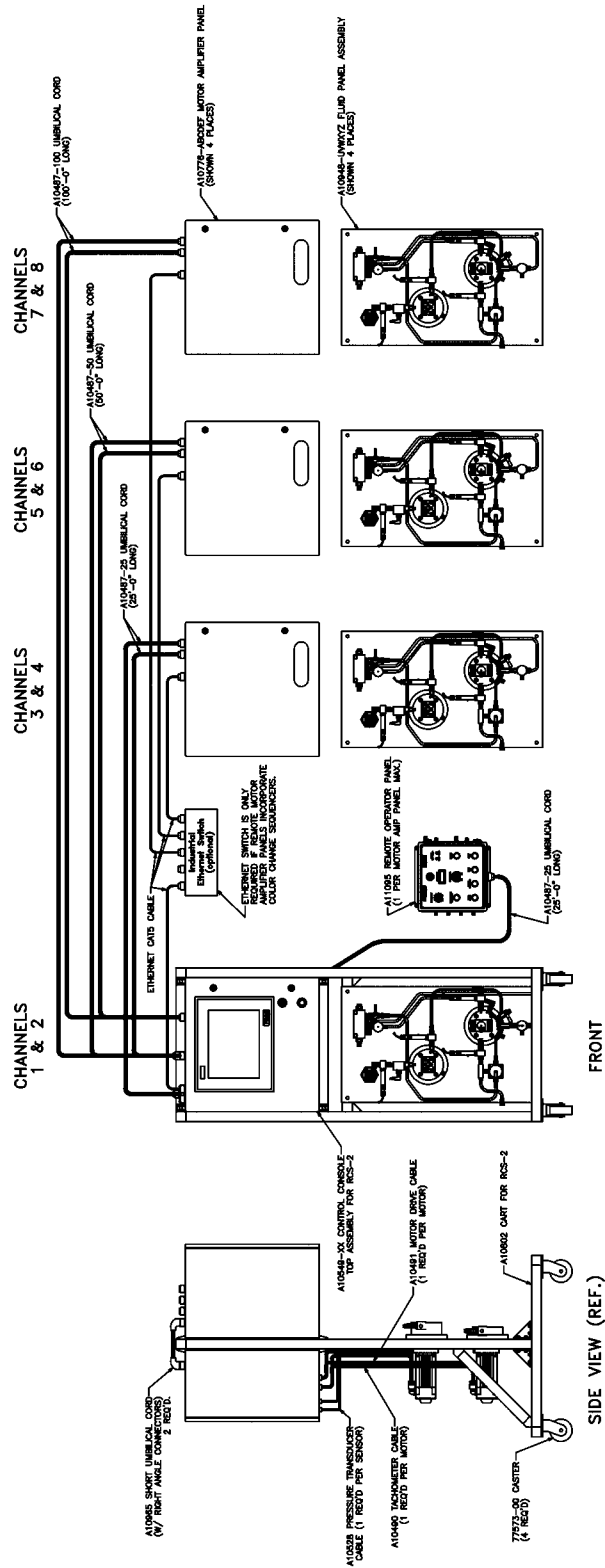

# APPENDIX G: SCHEMATICS

## CONTROL CONSOLE SCHEMATIC

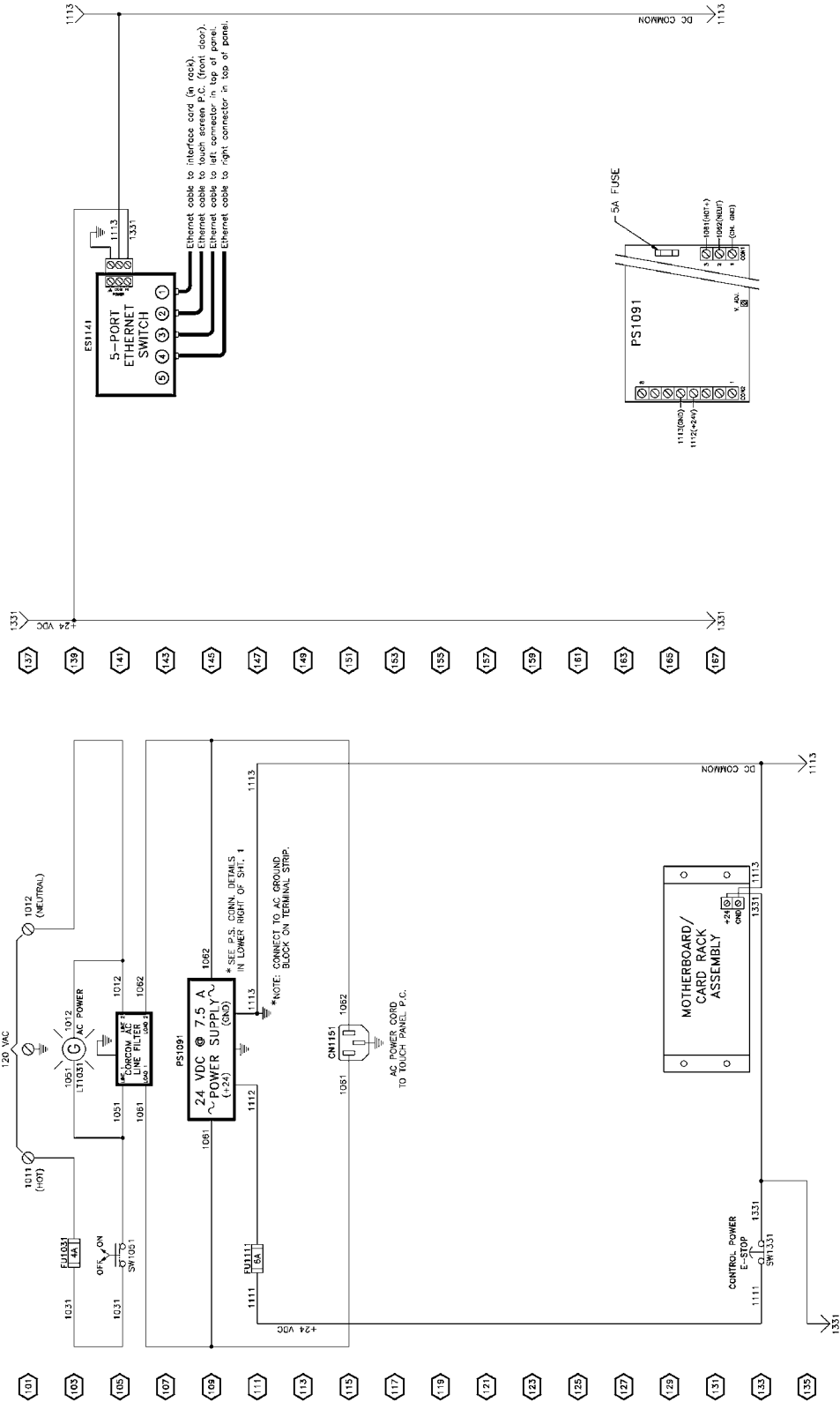

APPENDIX G: SCHEMATICS (Continued)

CONTROL CONSOLE SCHEMATIC

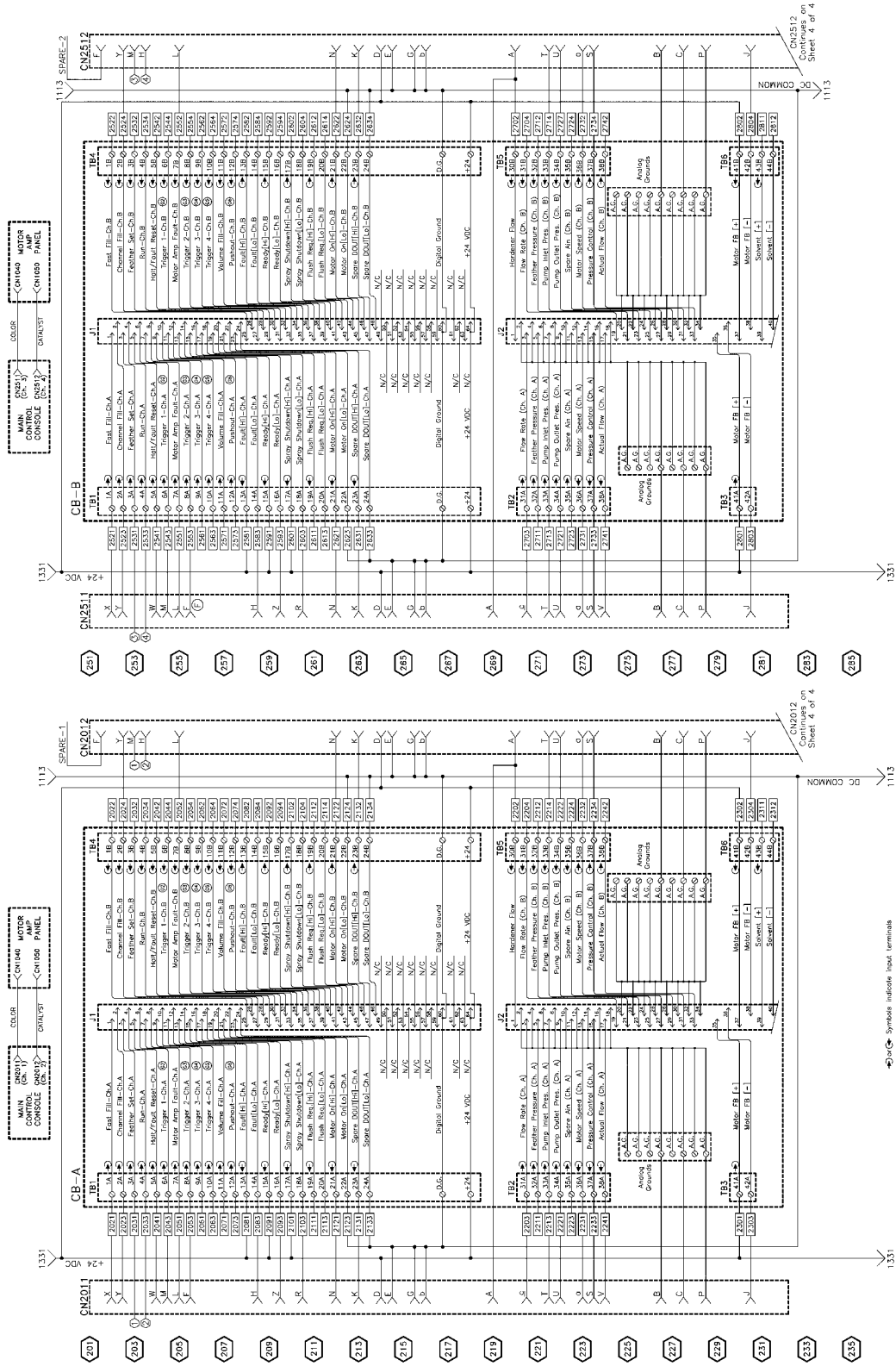

Symbol indicate input terminals  
 Symbol indicate output terminals

Continues on Sheet 4 of 4

Continues on Sheet 4 of 4

APPENDIX G: SCHEMATICS (Continued)

CONTROL CONSOLE SCHEMATIC

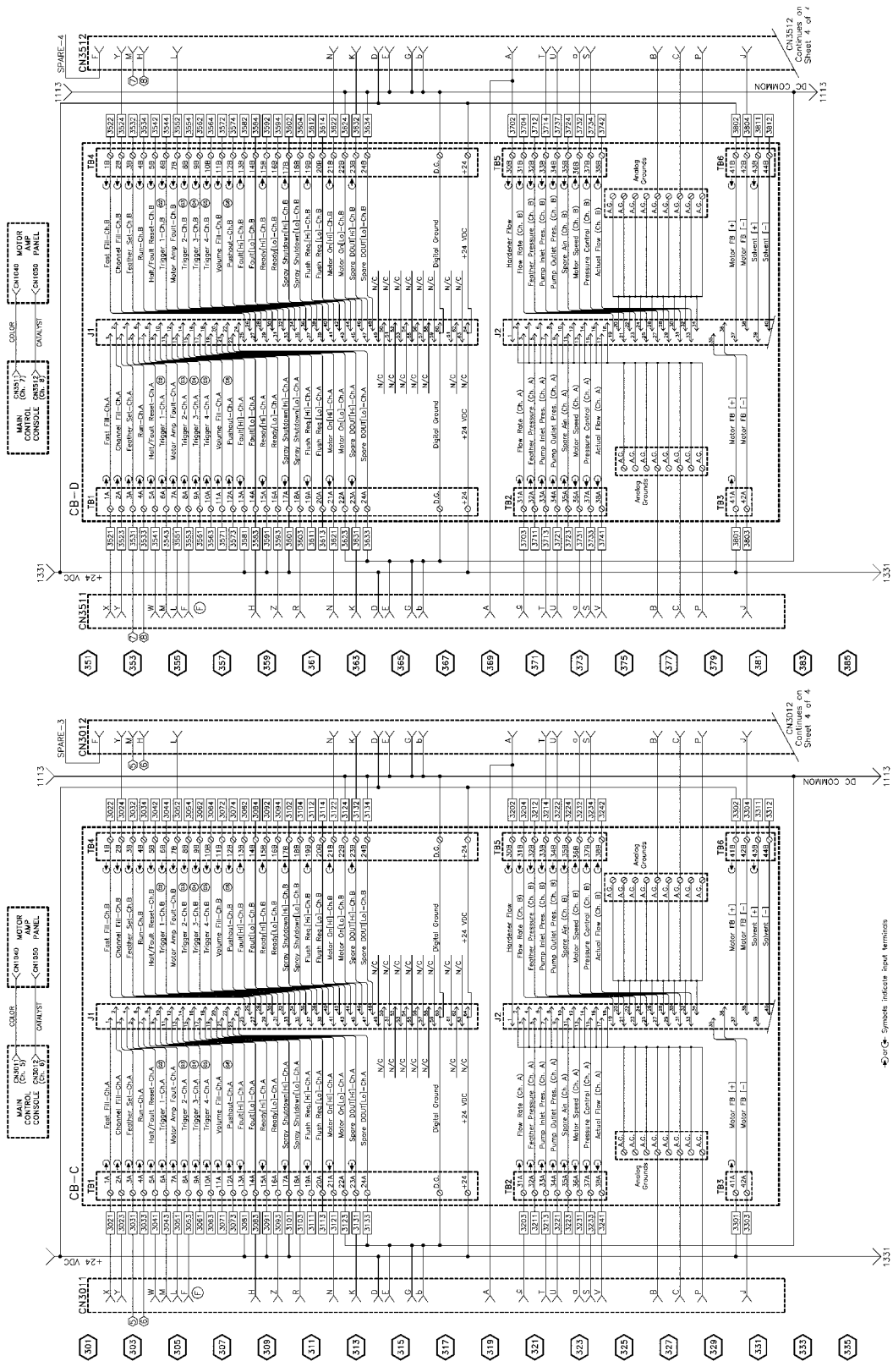

APPENDIX G: SCHEMATICS (Continued)

CONTROL CONSOLE SCHEMATIC

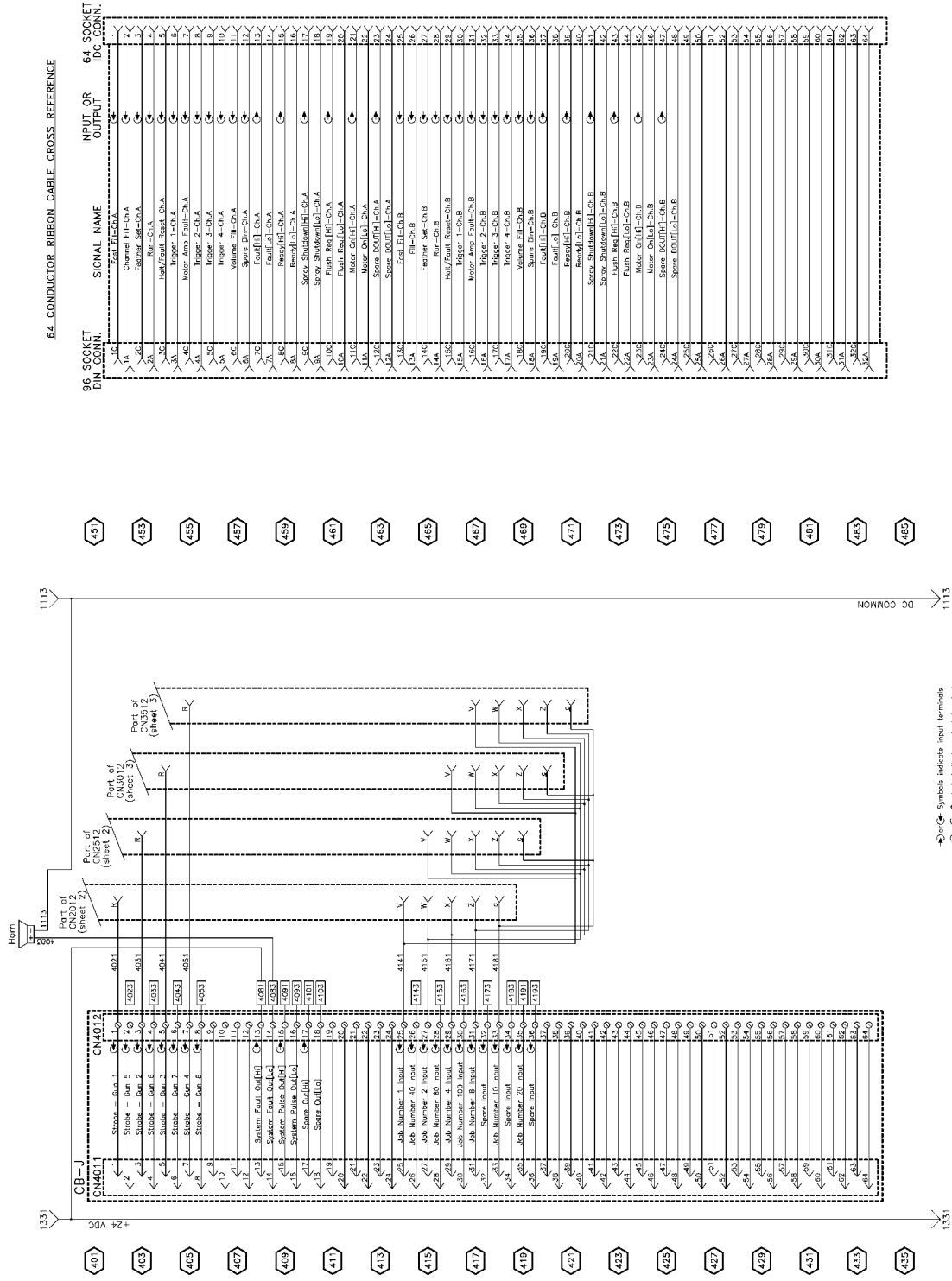



APPENDIX G: SCHEMATICS (Continued)

MOTOR AMP PANEL SCHEMATIC

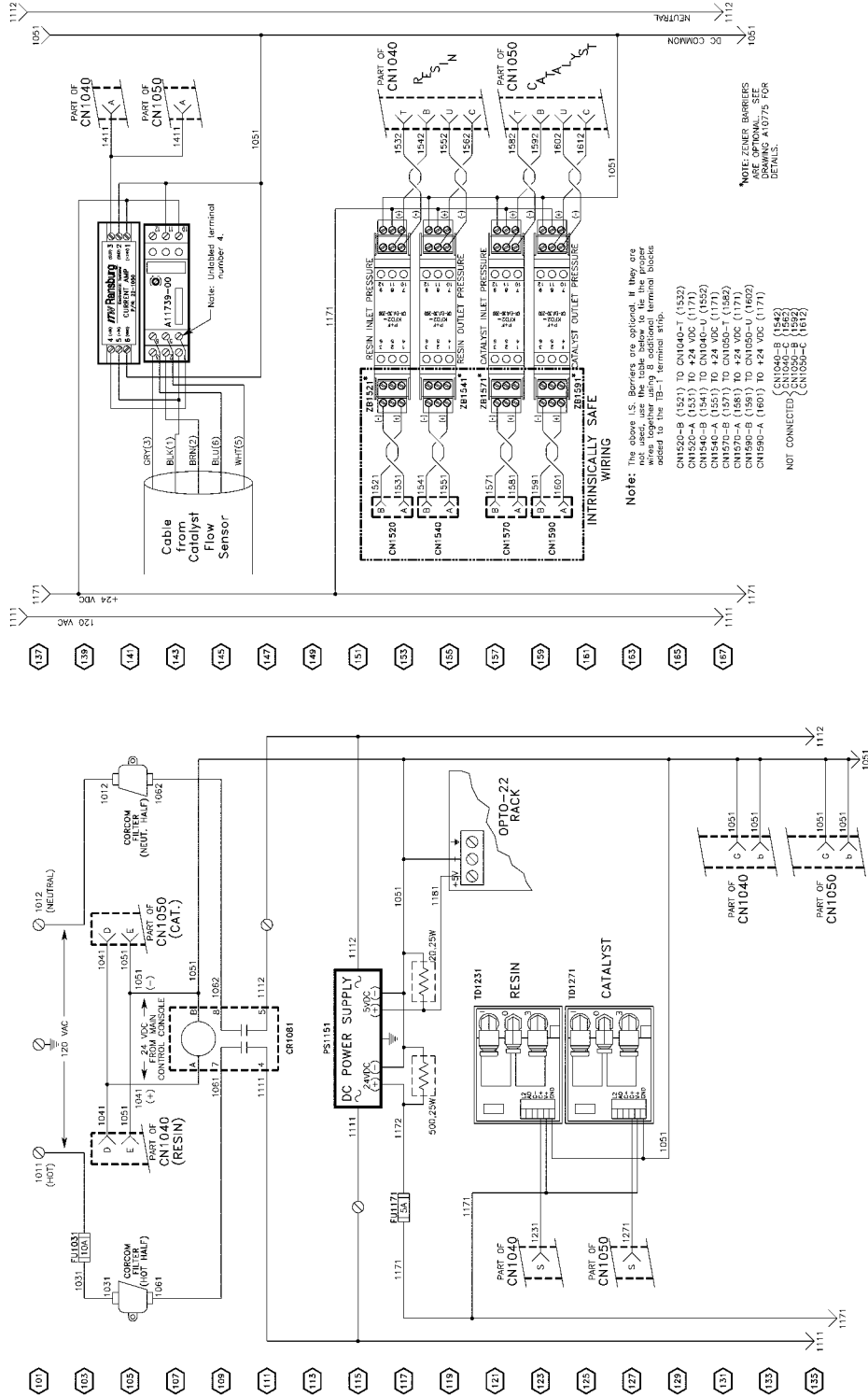

APPENDIX G: SCHEMATICS (Continued)

MOTOR AMP PANEL SCHEMATIC

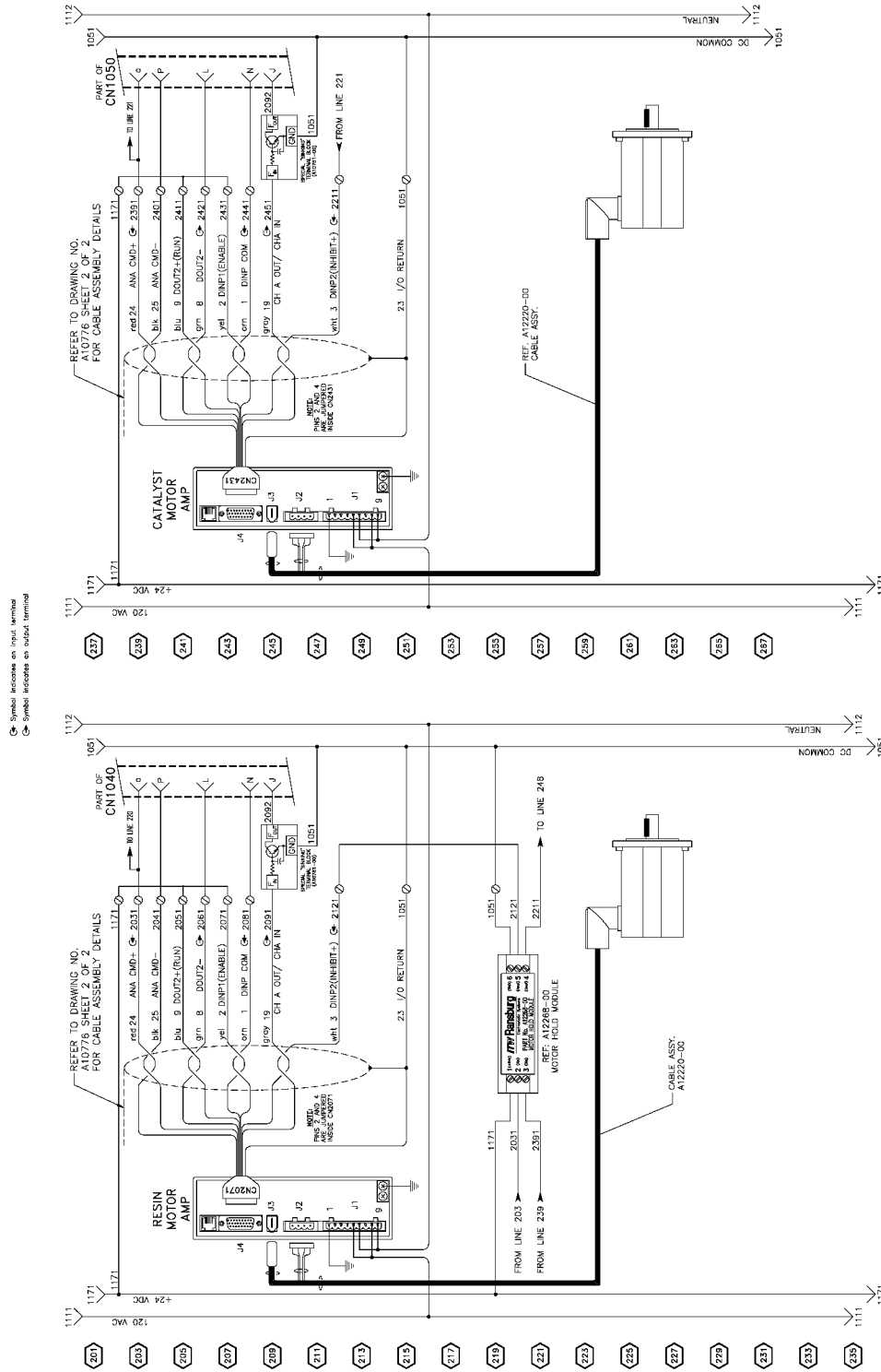

APPENDIX G: SCHEMATICS (Continued)

MOTOR AMP PANEL SCHEMATIC

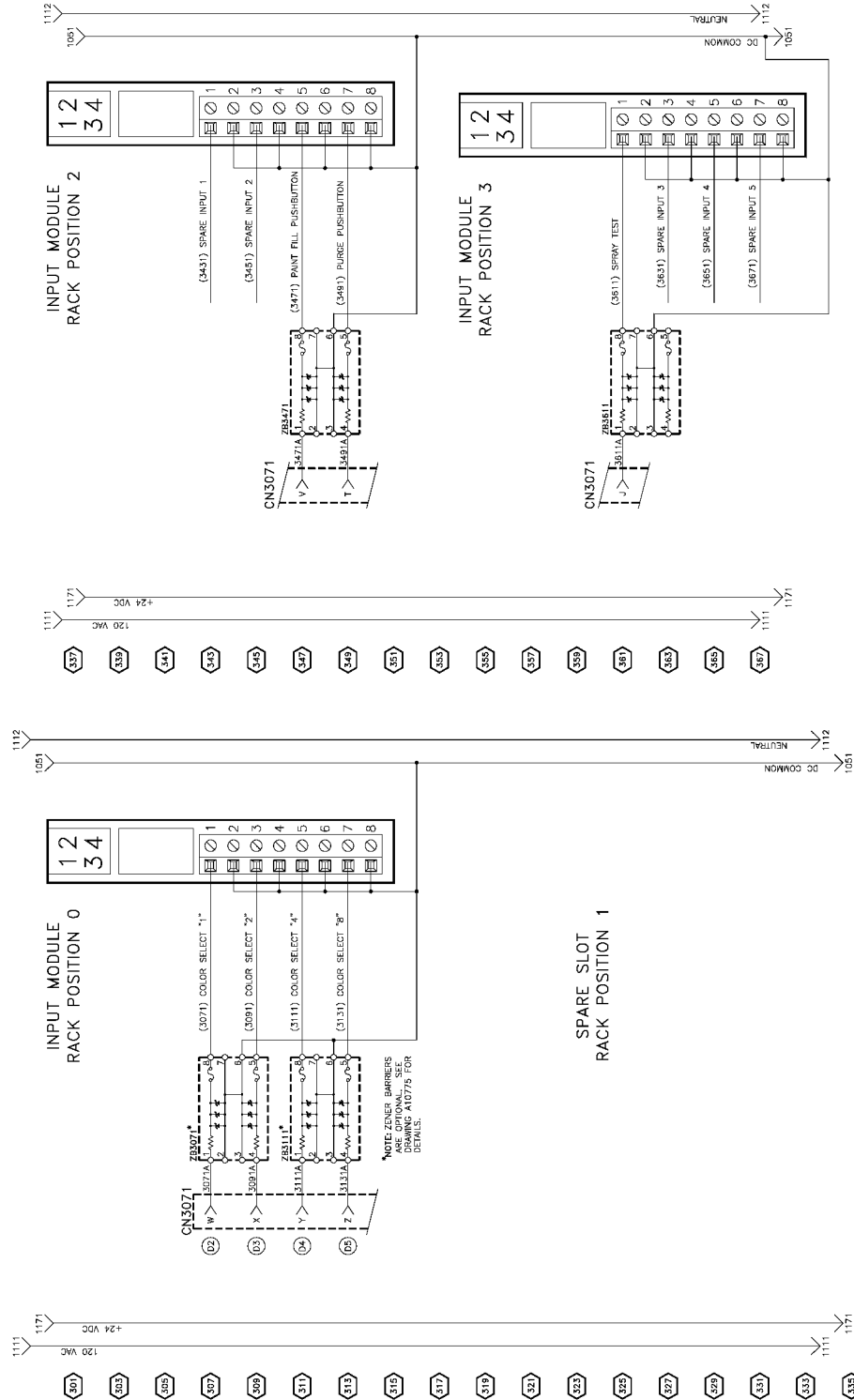

APPENDIX G: SCHEMATICS (Continued)

MOTOR AMP PANEL SCHEMATIC

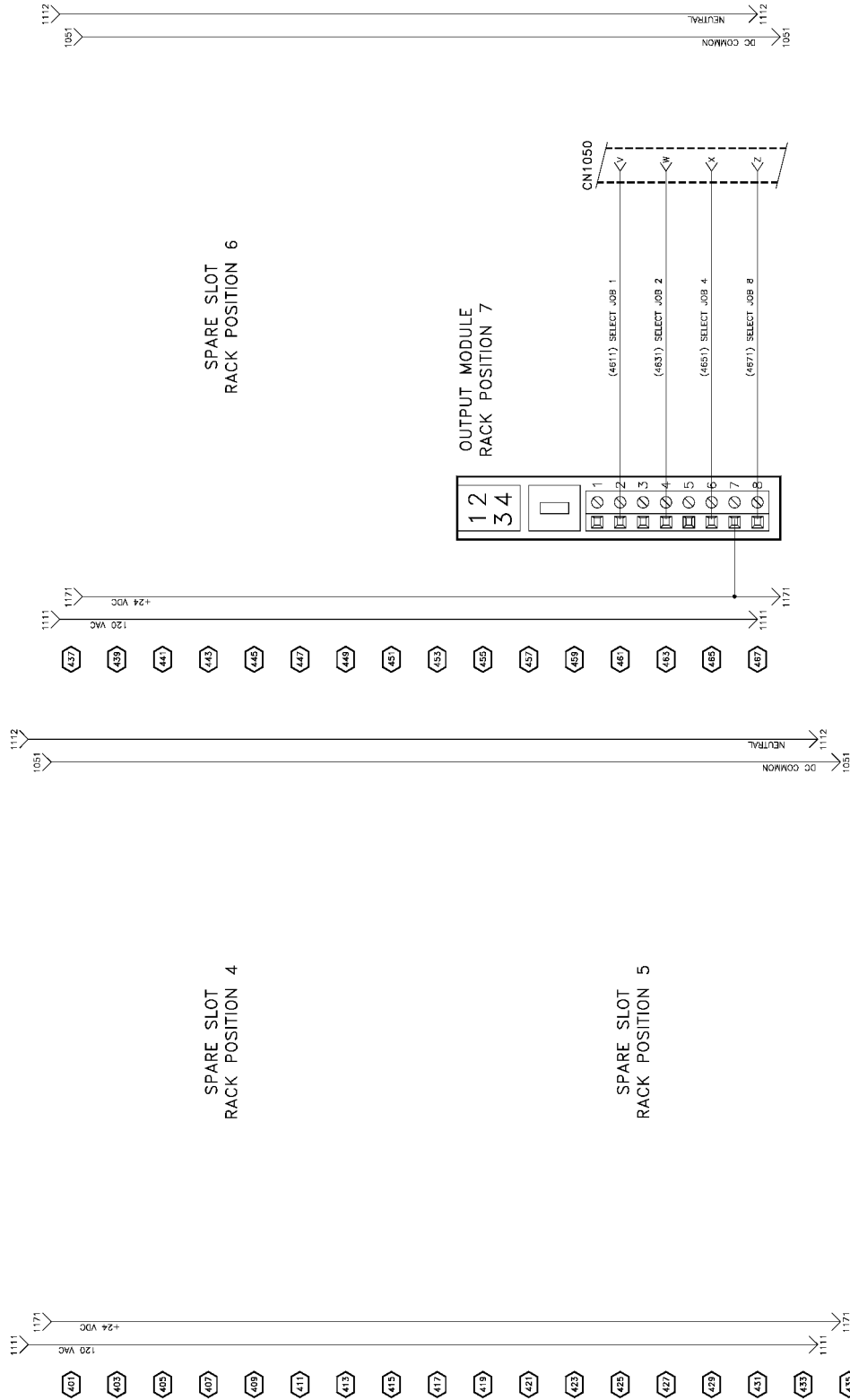

APPENDIX G: SCHEMATICS (Continued)

MOTOR AMP PANEL SCHEMATIC

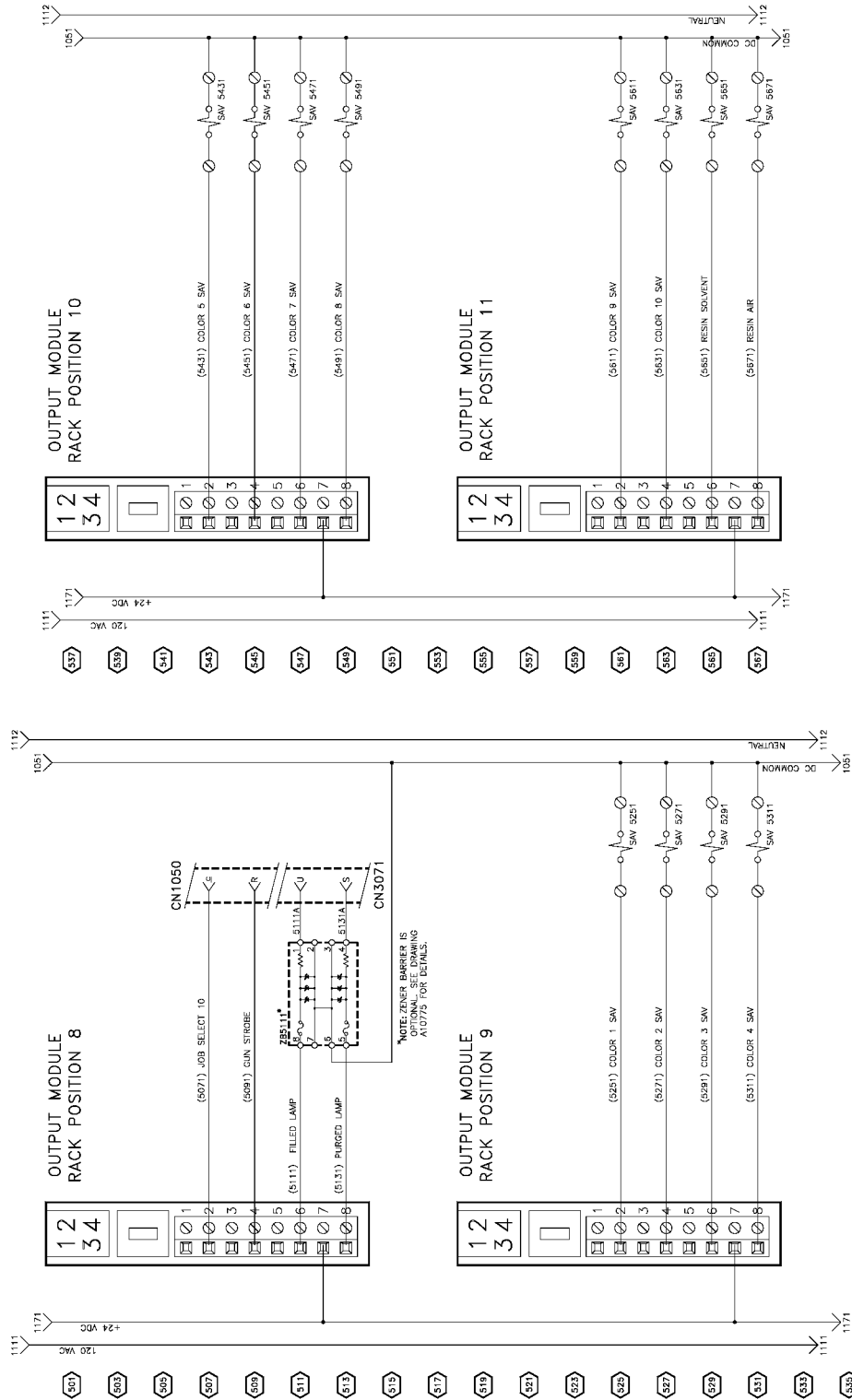

APPENDIX G: SCHEMATICS (Continued)

MOTOR AMP PANEL SCHEMATIC

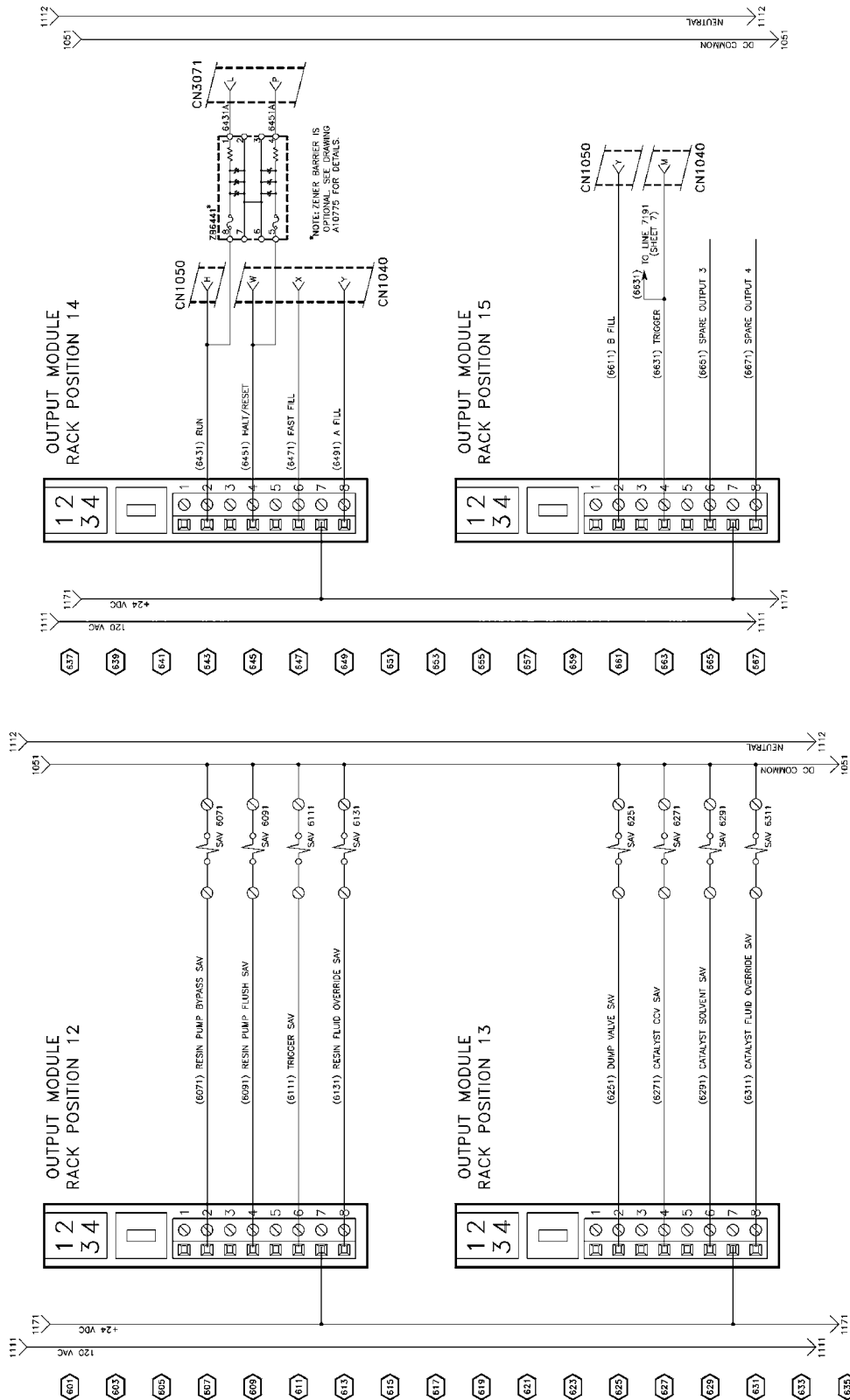

APPENDIX G: SCHEMATICS (Continued)

MOTOR AMP PANEL SCHEMATIC

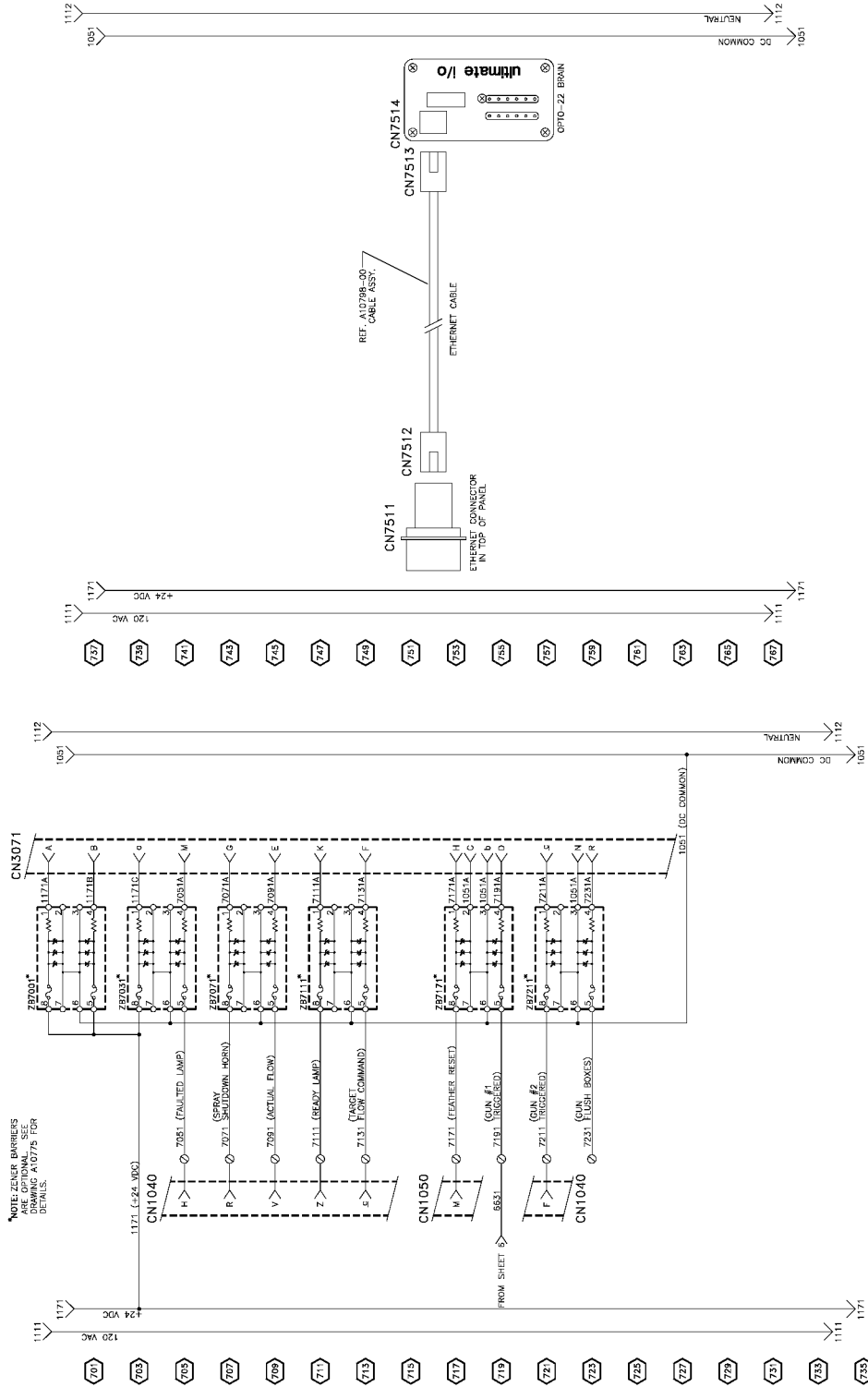

APPENDIX G: SCHEMATICS (Continued)

REMOTE OPERATOR PANEL SCHEMATIC

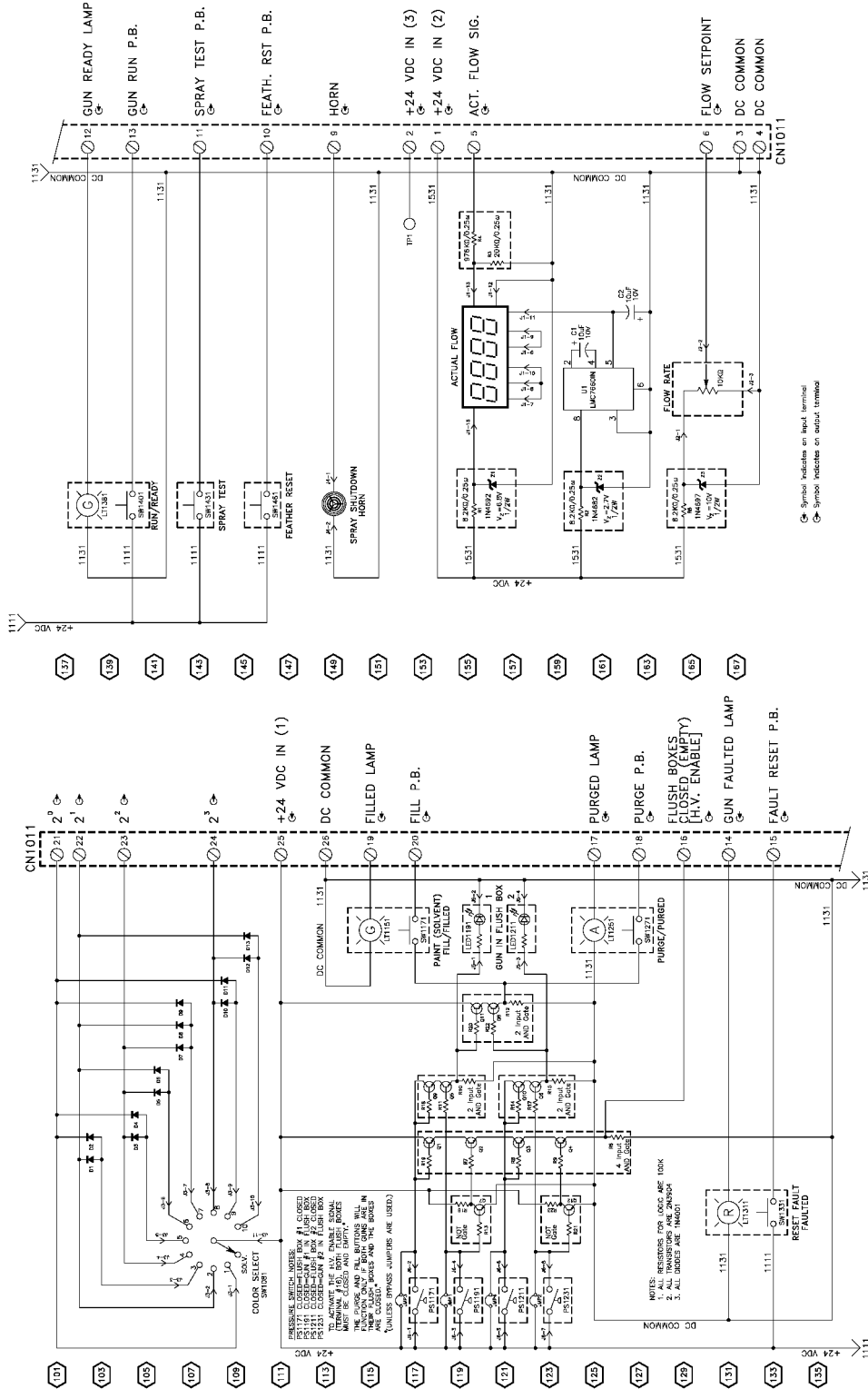



APPENDIX G: SCHEMATICS (Continued)

REMOTE OPERATOR PANEL SCHEMATIC

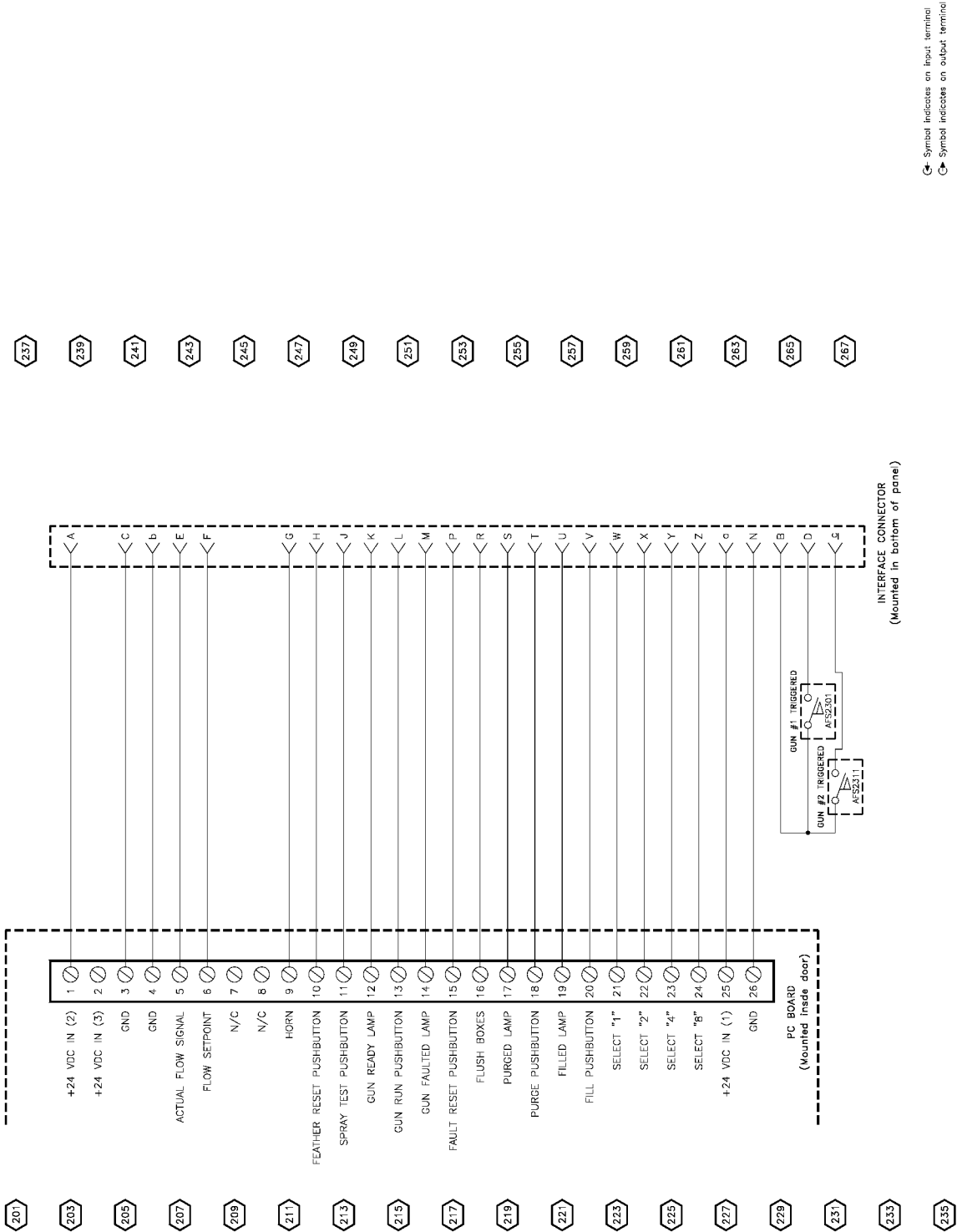

APPENDIX G: SCHEMATICS (Continued)

FLUID PANEL SCHEMATIC

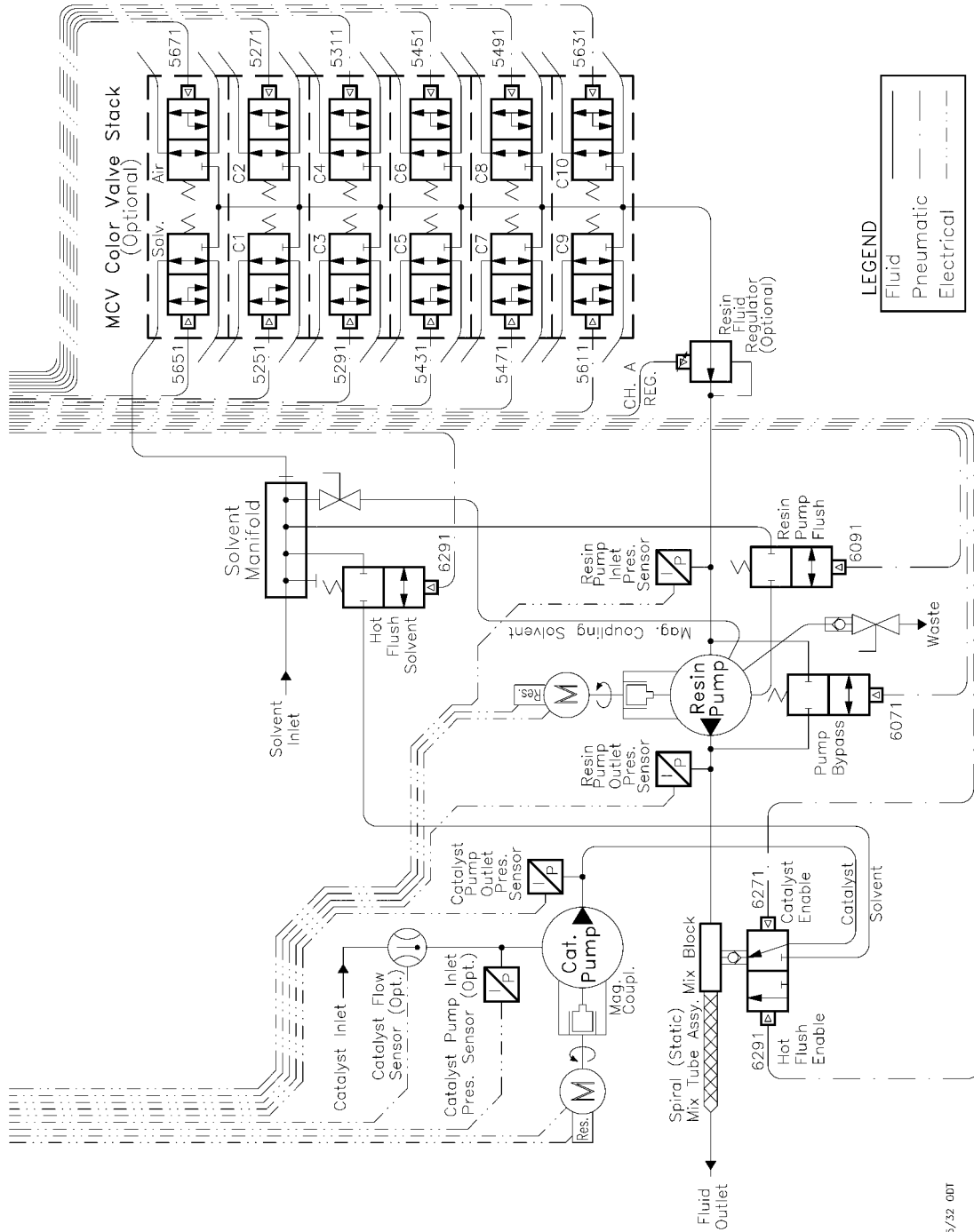

- 2) ALL PNEUMATIC LINES ARE 5/32 ODT (TR-SSEM-548).
- 1) ALL FLUID LINES ARE 3/8" ODT (SSP-5090) EXCEPT BETWEEN OUTLET OF CATALYST PUMP AND 3-WAY BALL VALVE, WHICH IS 5/16 ODT (76698-02).

NOTES:

## **MANUAL CHANGE SUMMARY**

This manual was published to supercede Service **Manual LN-9408-06.2, RCS-2 Parts, Maintenance and Troubleshooting Manual** to make the following changes:

1. Change logo.

**Service Manual Price: \$50.00 (U.S.)**

---

**Manufacturing**

1910 North Wayne Street  
Angola, Indiana 46703-9100  
Telephone: 260/665-8800  
Fax: 260/665-8516

**Technical/Service Assistance**

Telephone: 800/ 233-3366  
Fax: 419/ 470-2071

**Technical Support Representative will direct you to the appropriate telephone number for ordering Spare Parts.**

