



OWNERS AND SERVICE MANUAL

INNOVATIVE CONCEPTS IN ENTERTAINMENT INC.

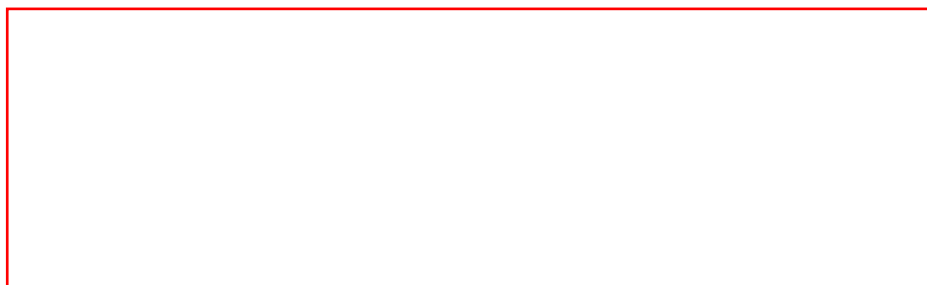

Table of Contents

Safety and Warnings	4
Game Play	5
Setup Configuration	6
Dipswitch Settings	7
Determine your Cost of prizes	8
Power supply information	9
Error codes and solutions	10
Board layout w/connectors	11
Wiring - Power, joysticks, and buttons	12
Wiring - Claw and coin.	13
Wiring - Motors	14
Tilt Adjustment	15
Cabinet and door glass replacement	16
Spares	17-18
Warranty	19

Rev: A

June 8, 2012

SAFETY AND WARNINGS BEFORE YOU BEGIN

WARNING: WHEN INSTALLING THIS GAME, A GROUNDED A.C. RECEPTACLE MUST BE USED. FAILURE TO DO SO COULD RESULT IN INJURY TO YOURSELF OR OTHERS. FAILURE TO USE A GROUNDED RECEPTACLE COULD ALSO CAUSE IMPROPER GAME OPERATION, OR DAMAGE TO THE ELECTRONICS.

NOTE: THIS GAME IS INTENDED FOR INDOOR USE ONLY.

DO NOT DEFEAT OR REMOVE THE GROUNDING PRONG ON THE POWER CORD FOR THE SAME REASON AS GIVEN ABOVE. USING AN IMPROPERLY GROUNDED GAME COULD VOID YOUR WARRANTY.

HAVE A QUALIFIED ELECTRICIAN CHECK YOUR A.C. RECEPTACLE TO BE SURE THE GROUND IS FUNCTIONING PROPERLY.

THIS GAME IS DESIGNED TO DISSIPATE STATIC ELECTRICITY THROUGH THE GROUNDING PLANE OF THE GAME. IF THE A.C. GROUND DOES NOT WORK, THE GAME COULD DISCHARGE STATIC ELECTRICITY THROUGH THE GAME CIRCUITRY, WHICH COULD CAUSE DAMAGE.

THE POWER SUPPLY IS NOT VOLTAGE ADJUSTABLE. TO OPERATE THE GAME AT VOLTAGES OTHER THAN THOSE IT WAS DESIGNED FOR. PLEASE CONTACT OUR SERVICE DEPARTMENT FOR VOLTAGE CONVERSION INFORMATION.

WARNING

DO NOT remove any of the components on the main board (e.g. compact flash and eproms) while the game is powered on. This may cause permanent damage to the parts and the main board. Removing any main board component part while powered on will void the warranty.

ALWAYS REMOVE POWER TO THE GAME, BEFORE ATTEMPTING ANY SERVICE, UNLESS NEEDED FOR SPECIFIC TESTING. FAILURE TO OBSERVE THIS PRECAUTION COULD RESULT IN SERIOUS INJURY TO YOURSELF OR OTHERS.

The game requires 3 amps of AC power from your AC outlet.

Game Play

INSTRUCTIONS

1) With Joystick Use Your SKILL
to Aim for Candy TARGET



2) Press Button to Drop Vacuum



Vacuum Must Land INSIDE
Center of Target to WIN

YOU WIN!

YOU LOSE

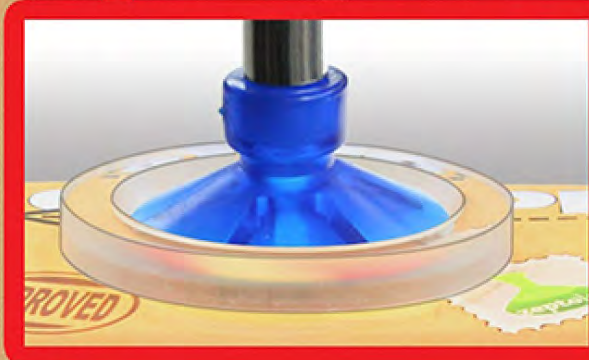

Setup / Configuration

In order to setup your game you will need to access the main PCB board. Open the large front door shown below. On the left wall you will find the main PCB circuit board. Located on the main PCB circuit board are the volume control, earphone jack, program/test buttons, and dipswitches. The dipswitches set the price of play, enter test modes, and disable attract audio.

The switch labeled “Coin/Sw” will credit the machine without advancing the Coin Meter. The “MODE”, “UP”, and “DOWN” buttons are used when in test mode.

The dipswitch settings can be found on the next page.

To adjust the volume control, turn the knob to increase or decrease the volume levels.

The “CLR” button clears credits.

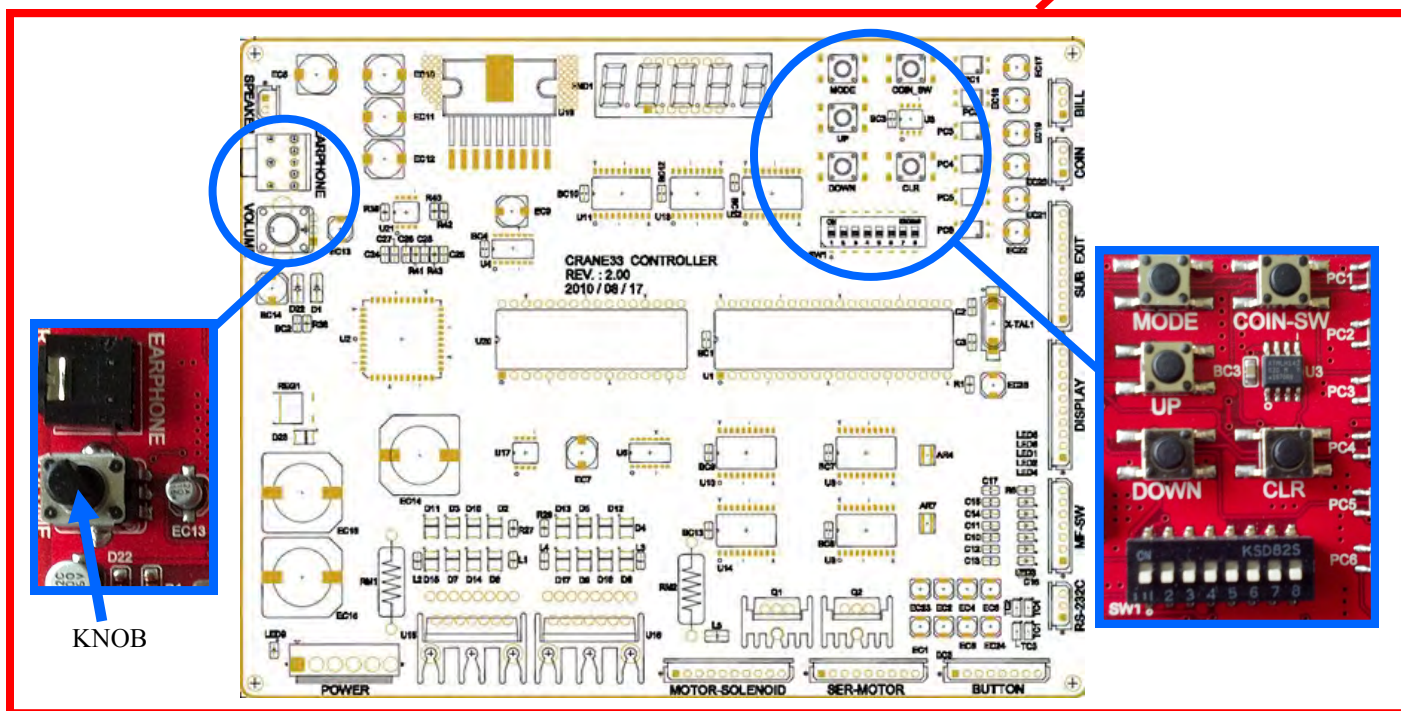
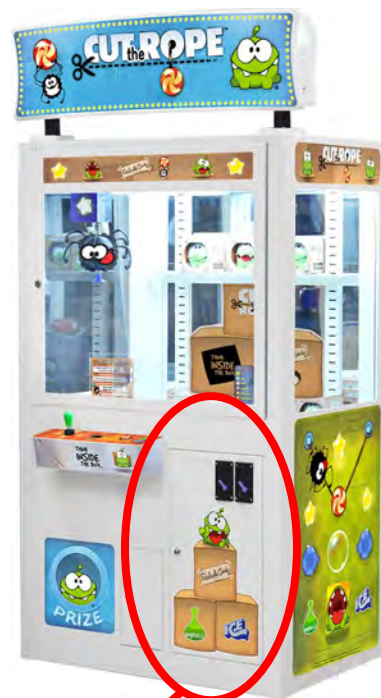

DIP Switch Settings								Function
SW 1	SW 2	SW 3	SW 4	SW 5	SW 6	SW 7	SW 8	
Off	Off	Off						1 coin (pulse) = 1 play
On	Off	Off						2 coins (pulses) = 1 play
Off	On	Off						3 coins (pulses) = 1 play
On	On	Off						4 coins (pulses) = 1 play
Off	Off	On						5 coins (pulses) = 1 play
On	Off	On						6 coins (pulses) = 1 play
Off	On	On						7 coins (pulses) = 1 play
On	On	On						8 coins (pulses) = 1 play
			Off					Factory Use
			On					
				Off				Tilt Off; Game will sound alarm and reset. Game will still function.
				on				Tilt On; Game will display E7 and no longer work. Game must be powered down to reset. Game will remain out of order until power is cycled.
					Off			
					On			Test Mode
						Off		Demo Sound Off
						On		Demo Sound On
							Off	Play till you win, disabled.
							On	Play till you win, enabled. Game will continue to give a credit and allow the player to play until a prize has been seen by the prize sensor.

Setup - How to determine your cost of Prizes.

Cut the Rope is a pure SKILL game!

There are 5 distinct discs available that are to be adhered to prizes, using 3M double sided tape. Each disc is labeled and color coded, making it easier to distinguish from EASIER to MORE DIFFICULT.

ICE suggests using no more than 12 prizes on the playfield at any time.

The “estimated win ratio” noted in the guide below was based on extensive testing, but can vary depending on the skill of the player.

Your actual Payout Percentage will vary based on 4 factors: Cost of game, Cost of Prize, Difficulty level of disc, and the Skill of the player.

Example:

- If the cost of your chosen prize is \$5, and you use the E (green and yellow) disc, assuming a \$1 per game cost, we estimate a prize will be won every 25 games. This would equal a 20% payout (\$5 prize/\$25 in game play).
- If the cost of your chosen prize is \$25, and you use the C (orange and yellow) disc, assuming a \$1 per game cost, we estimate a prize will be won every 75 games. This would equal a 33% payout (\$25 prize/\$75 in game play).
- If the cost of your chosen prize is \$100, and you use the A (red and yellow) disc, assuming a \$.50 per game cost, we estimate a prize will be won every 500 games. This would equal a 40% payout (\$100 prize/\$250 in game play).

To Determine Your Prize Values, please use the following guide:

For A use $500 \times \text{CPP} \times \text{DPP} = \text{Maximum Cost of Prize}$.

For B use $100 \times \text{CPP} \times \text{DPP} = \text{Maximum Cost of Prize}$.

For C use $75 \times \text{CPP} \times \text{DPP} = \text{Maximum Cost of Prize}$.

For D use $50 \times \text{CPP} \times \text{DPP} = \text{Maximum Cost of Prize}$.

For E use $25 \times \text{CPP} \times \text{DPP} = \text{Maximum Cost of Prize}$.

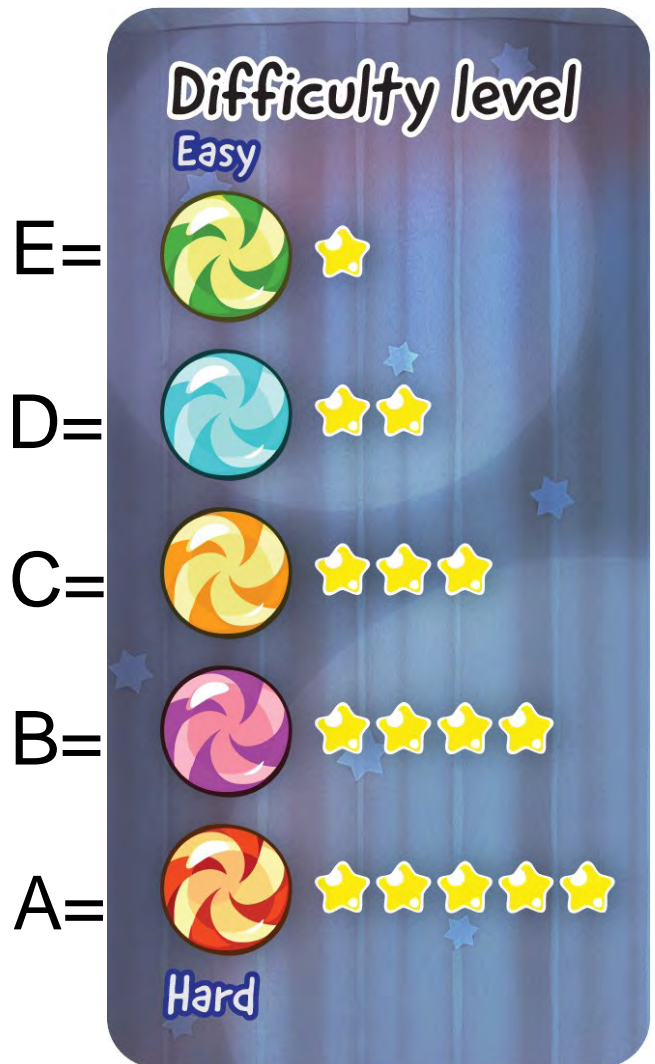

Estimated Payout Guide.					
Target Value (puck)	A	B	C	D	E
Prize Value Range	Hard	←————→			Easy
Estimated Win Ratio	1 in 500	1 in 100	1 in 75	1 in 50	1 in 25

TROUBLE SHOOTING

Power supply

The power supply is a ICE part number UC2010.

Yellow wires are +12 volts of DC.

Red wires are +5 volts of DC.

Black wires are grounds.

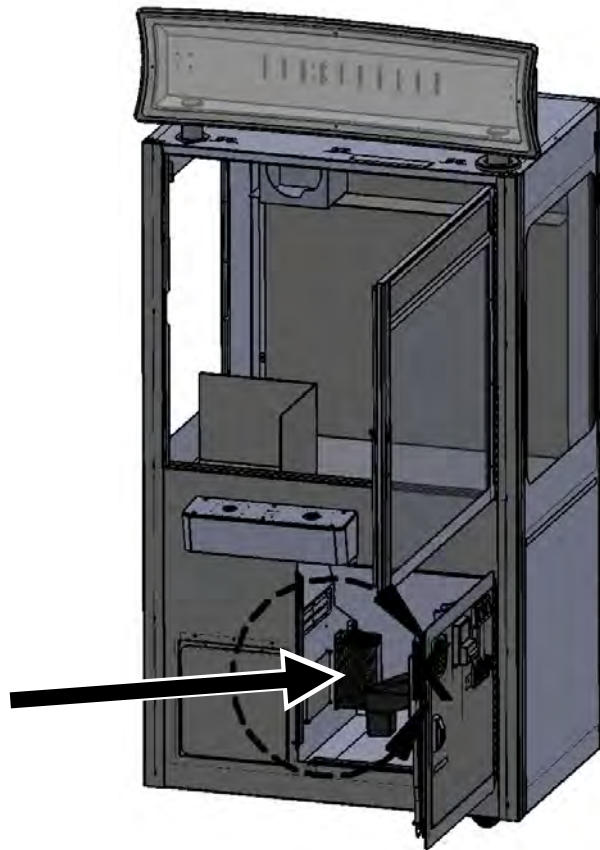
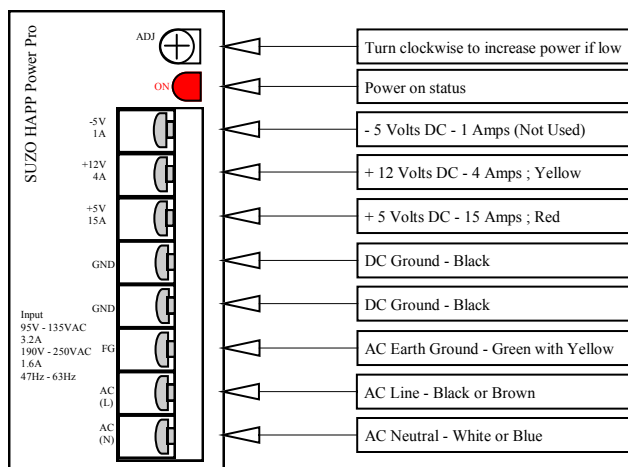

Checking DC Voltages

Volt test with the volt meter set to DC voltage. The +5 output can be adjusted by turning the adjustment screw of the power supply. Adjust to as close to +5 as possible. Increasing the +5 will also increase the +12. The voltage range can be plus or minus 5%.

Positive Probe:
Connect to +12V on power supply
(orange wire to power supply)

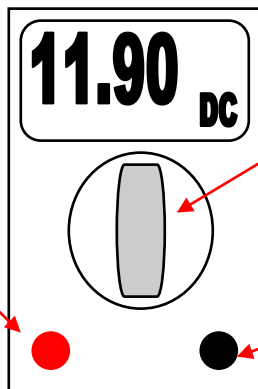

Turn to DC voltage check

Ground Probe:
Connect to GND on power supply
(Black wire to power supply)

Trouble Shoot: Error Codes

When either a switch is not seen or a motor doesn't work the crane will display a error code telling you what error it has encountered. Refer to the chart below for description of those error codes and suggestions to resolve them.

Error	Code Number displayed
HOME –Switch	E1 ; Check switch.
BACK—Switch	E2 ; Check switch.
LEFT—Switch	E3 ; Check switch.
RIGHT– Switch	E4 ; Check switch.
Up– Switch	E5 ; Check switch.
DOWN-Switch	E6 ; Check switch.
TILT ERROR ; See dip settings.	E7 ; Cycle power to clear!
HOME,BACK—Motor	EA ; Check motor. See below.
LEFT, RIGHT—Motor	EB; Check motor. See below.
UP, DOWN—Motor	EC ; Check motor. See below.

Problem	Check	Solution
Error EA, or EB error	Check U15, pins 4 & 9 for +12 VDC, check RM1 Check U15, pins 2/3, 13/14 for outputs. Check U15, pins 1 &15 Check L1, L2 Check U17	Replace RM1, U15, L1,L2, U17.
** IF U15 BAD **	Check D11, D3, D10, D2, D15, D7, D14, and D16.	Replace defective diodes.
Error EC	Check U16, pins 4 & 9 for +12VDC, check RM2 Check U16, pin 1 Check L3 Check U17	Replace RM2, U16, L3.U17.
Coin or Prize meter non-working	Check U16, pins 4 & 9 for +12VDC, check RM2 Check U16, pins 3 & 4 for meter pulses Check U16, pin 15 Check L4 Check U17	Replace RM2, U16, L4, U17.
** IF U16 BAD **	Check D13,D5,D12,D4,D17,D9,D17, and D8	Replace defective diodes.
No Vacuum control	Check Q1, D19.	Replace Q1, D19.
Prize door doesn't open	Check Q2, D20 and D21	Replace Q2, D20, D21.
No Audio	Check U19 and U21.	Replace U19, U21.
No Display	Check U5 (ULN2003)	Replace U5
No inputs	Check PC1 - PC6 (PC817)	Replace PC1 - PC6.
No +12	Power supply, Reg1 (7812)	Replace power supply, Reg1.

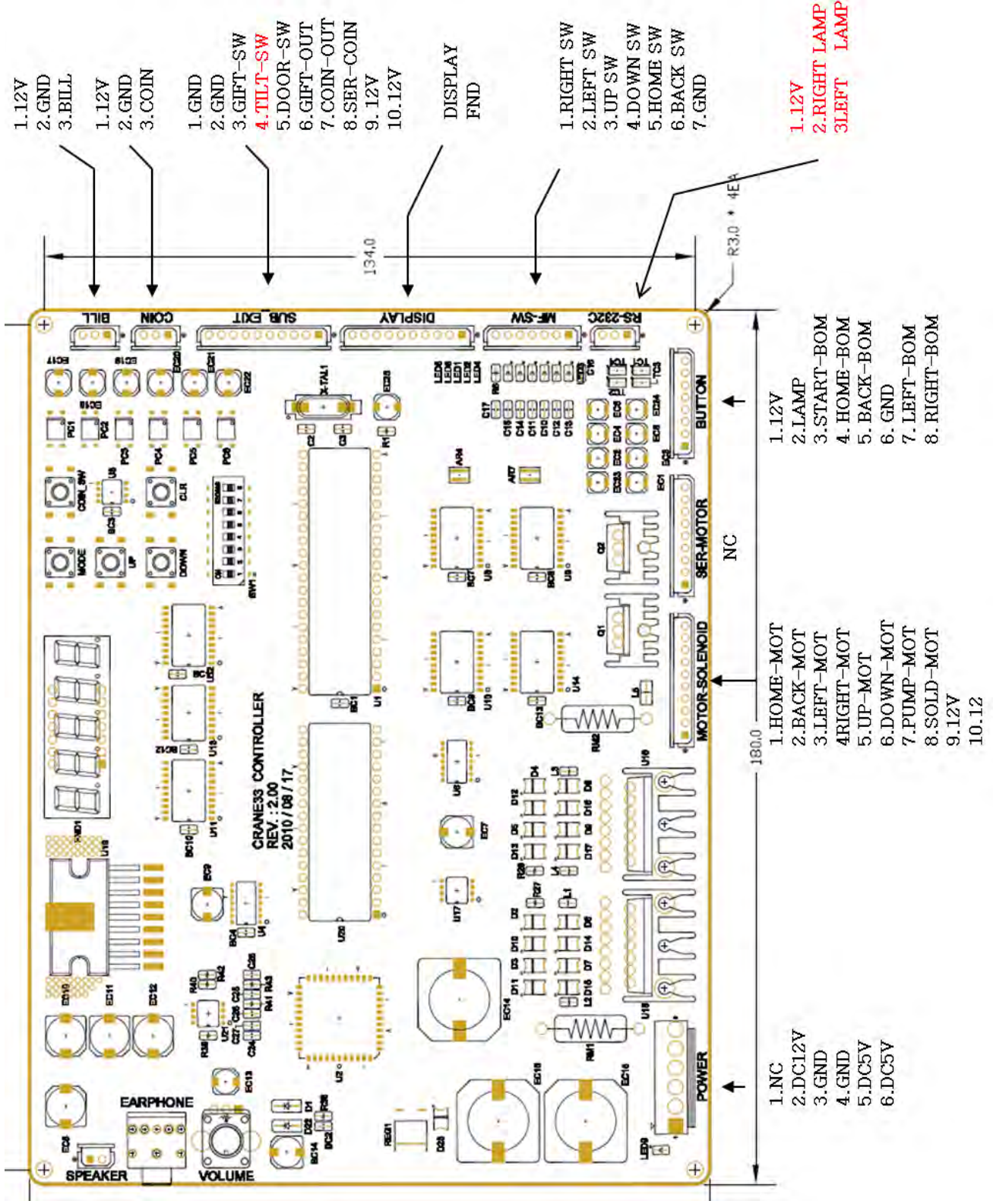

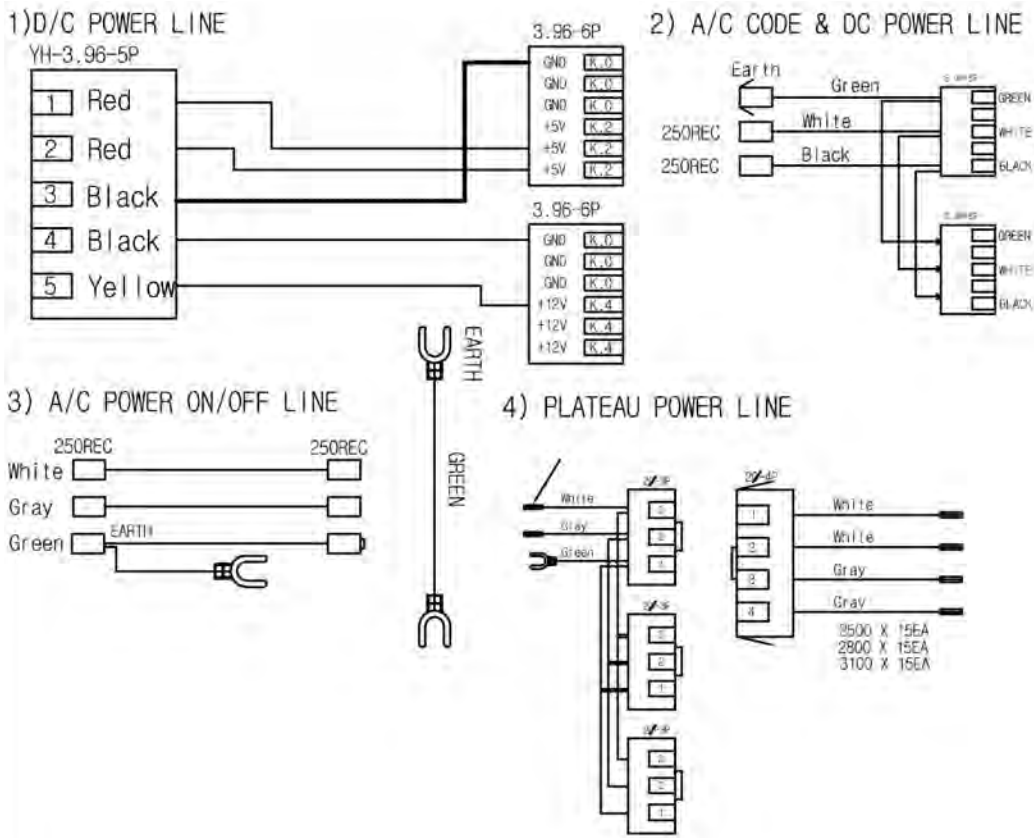

Joystick & Button

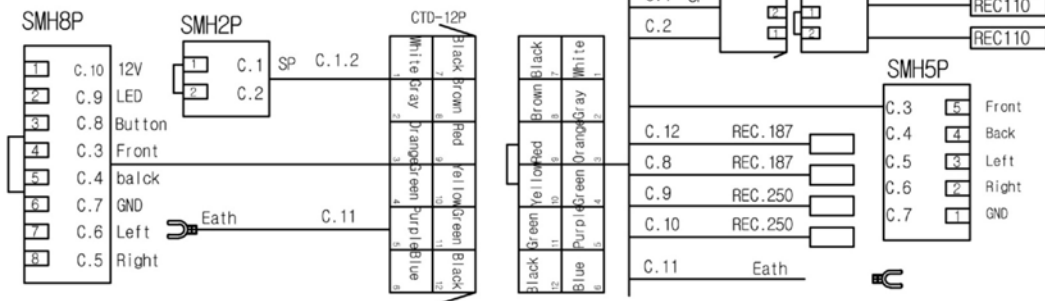

1) FND

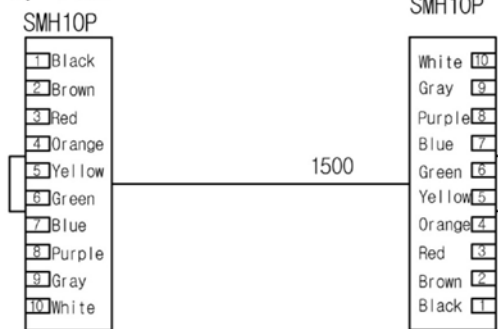

1) Gift Sensor

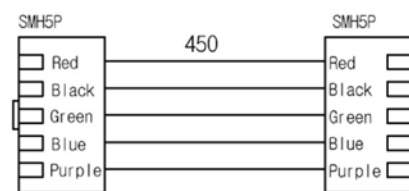

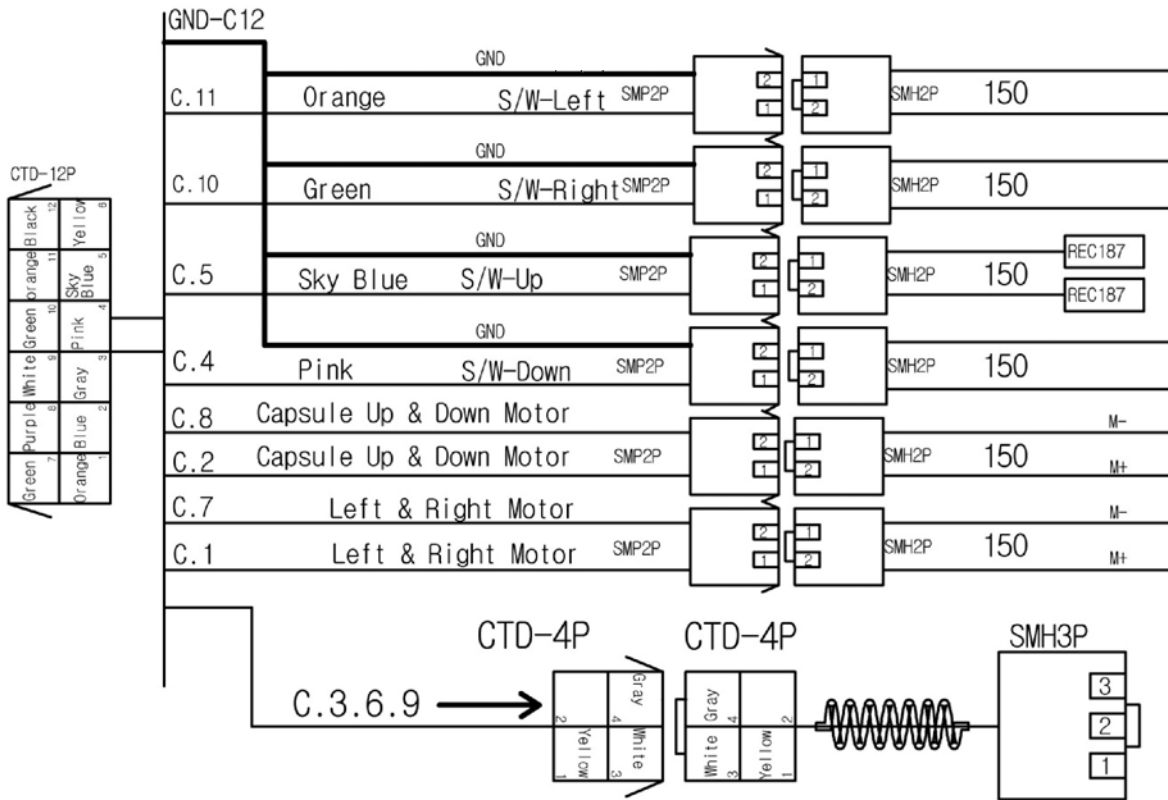

1) Coin, Bill

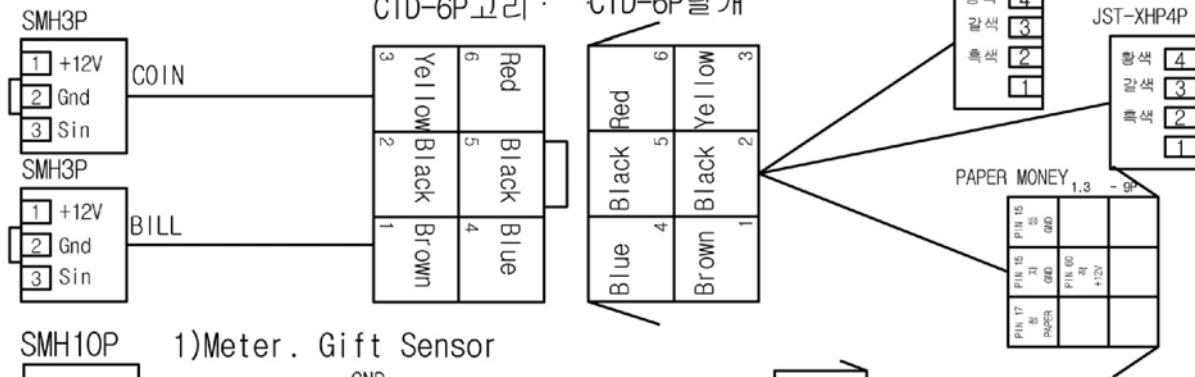

1) Meter. Gift Sensor

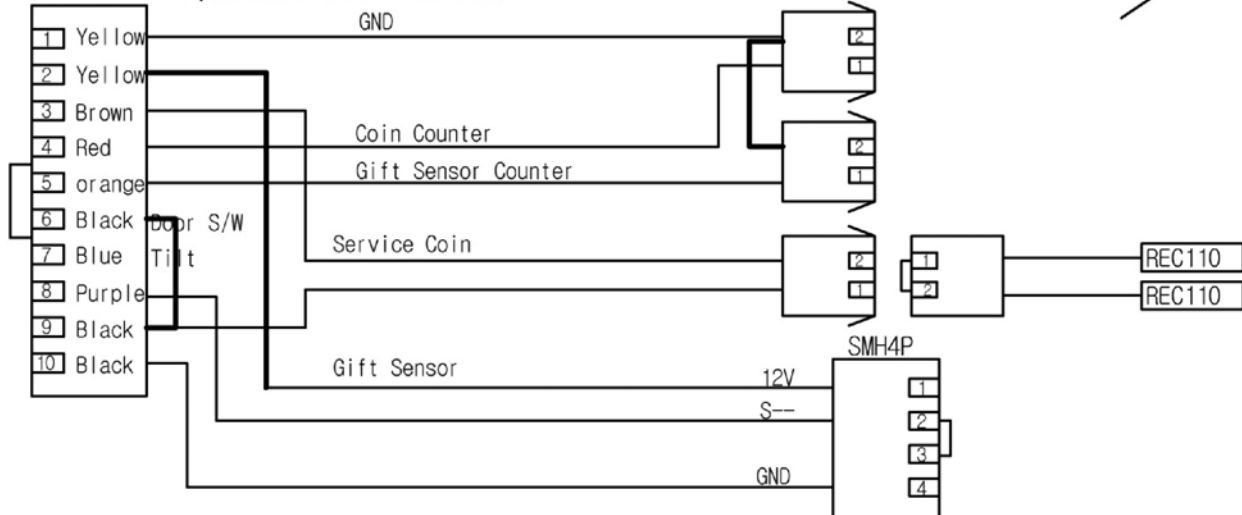

SMH10P

1	M-	Brown	Bakc & front	C.11
2	M+	Red	Bakc & front	C.1
3	M-	Orange	Left & Right	C.12
4	M+	Green	Left & Right	C.2
5	M-	Blue	Capsule Up & Down	C.13
6	M+	Purple	Capsule Up & Down	C.3
7	Breathe in	Gray		C.14
8	Valve	White		C.4
9	12V	Yellow		C.8
10	12V	Yellow		C.18

CTD-20P

1	Red	Brown	11	Brown
2	Green	Orange	12	Blue
3	Purple	Blue	13	Gray
4	White	Gray	14	Sky Blue
5	Pink	Sky Blue	15	Orange
6	Green	Orange	16	Brown
7	Red	Brown	17	Yellow
8	Yellow	Black	18	Black
9	Black	Black	19	Black
10	Black	Black	20	Black

SMH7P

1	GND	Black	C.9
2	S/W-Back	Brown	C.17
3	S/W-Front	Red	C.7
4	S/W-Left	Orange	C.16
5	S/W-Right	Green	C.6
6	S/W-Up	Blue Sky	C.15
7	S/W-Down	Pink	C.5

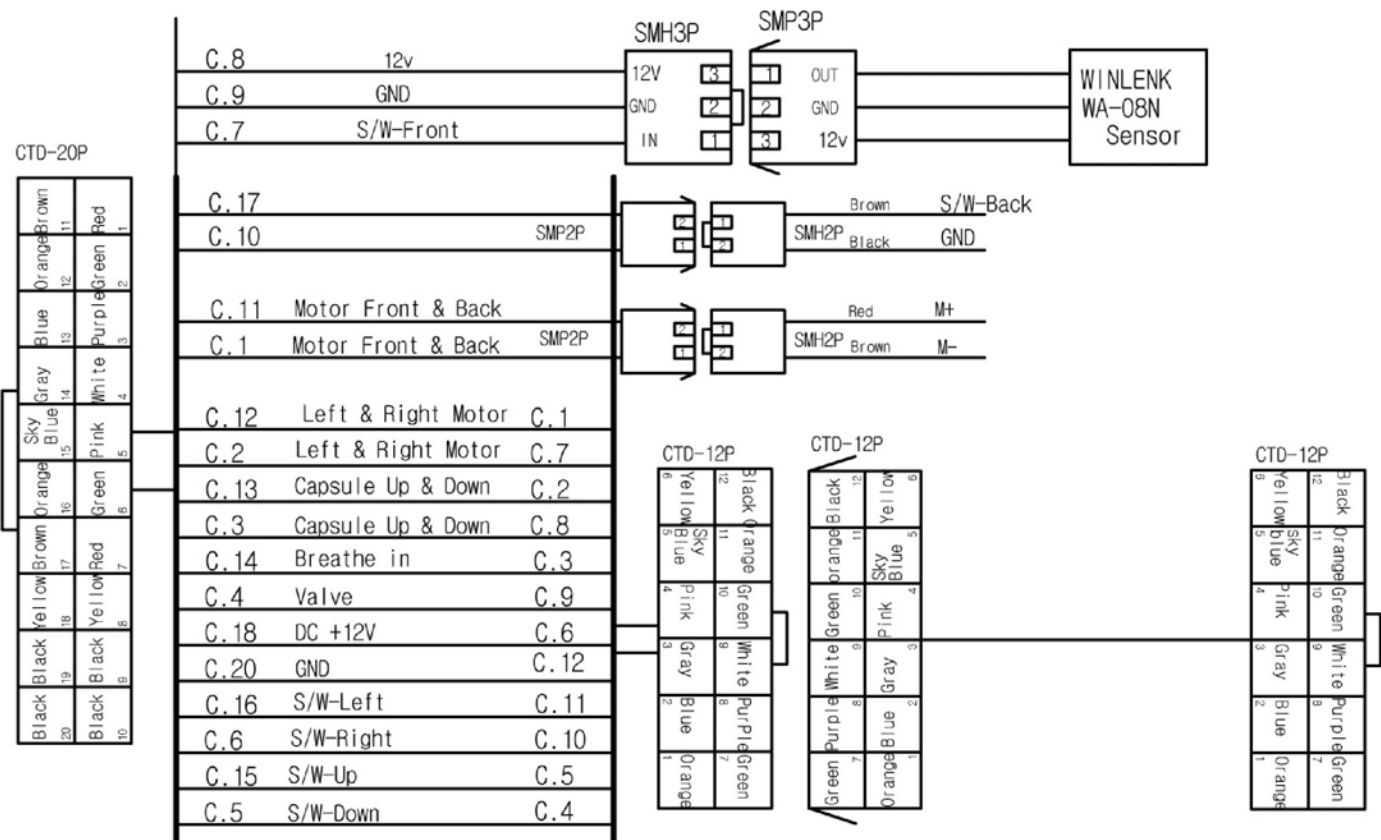

Tilt Adjustment

Level the game before setting the tilt bobbin and before you power on the crane. If you enable the tilt option it is important that the tilt bobbin is adjusted properly. Adjust the tilt bob so that there is between 1/16" to 1/8" is present all around. Loosen the wing nut, adjust the bobbin up or down and then tighten the wing nut.

- 6158 4X
(#6 FLAT WASHER)
- 6098 8X
(#6 SPLIT WASHER)
- 6328 4X
(CERAMIC ISOLATOR)
- 641 4x
6-32 x 1/4" Machine Screw
- CP1051
(TILT BOB)

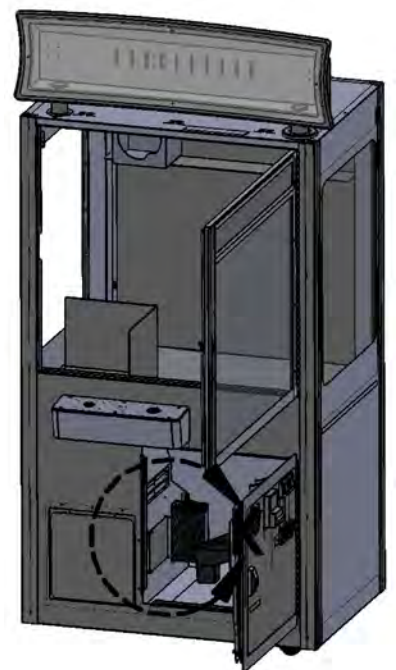
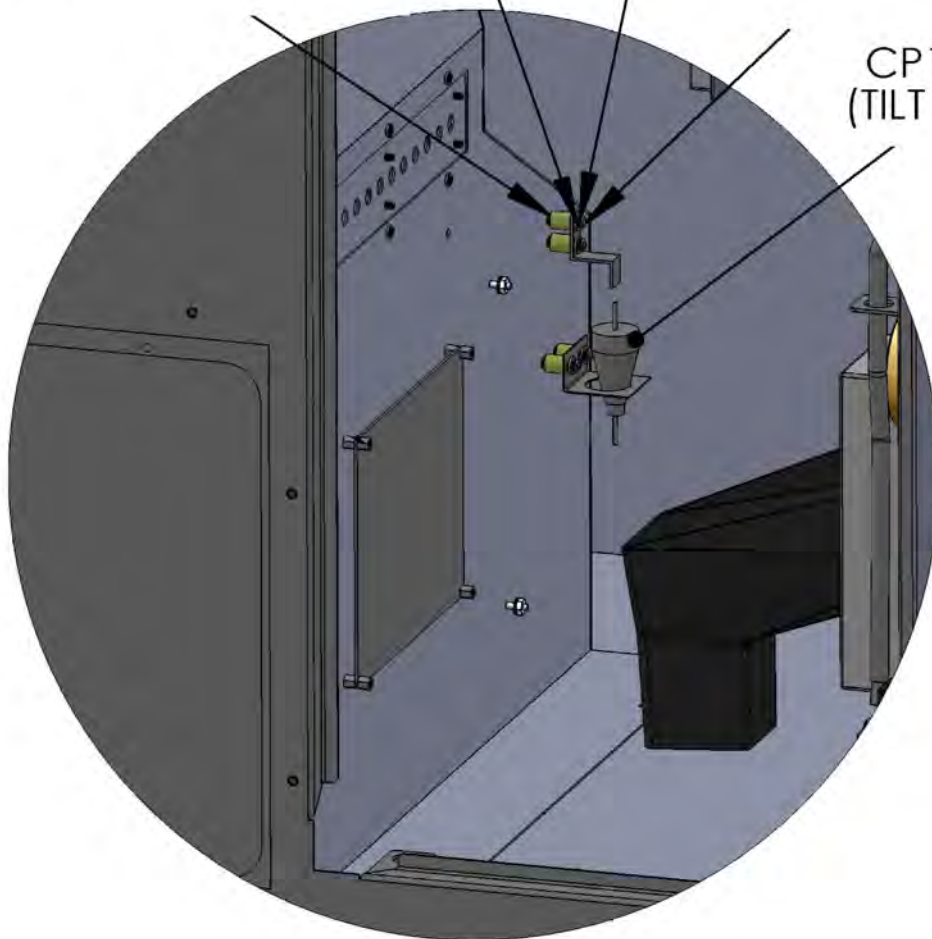

Replacing Cabinet and Door Glass

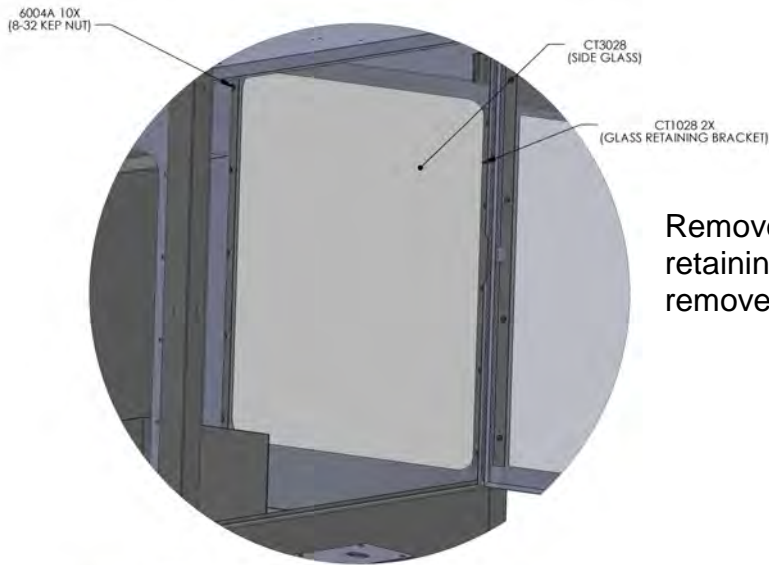

Remove the 10 8-32 Kep nuts that hold the glass retaining bracket to the cabinet. The glass can be removed. Reassembly in reverse order.

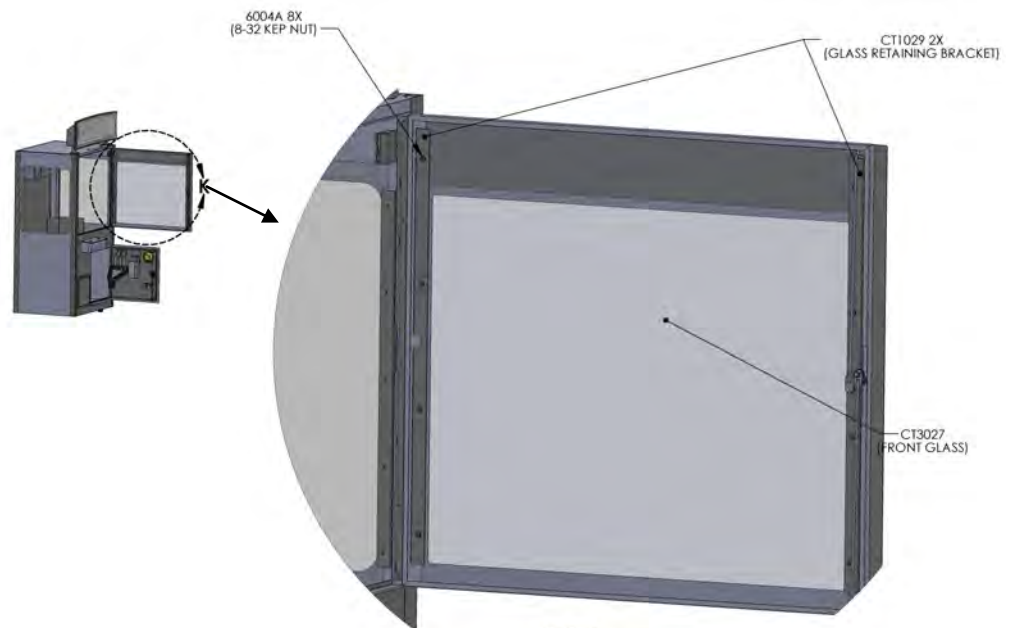

Remove the 8 8-32 Kep nuts that hold the glass retaining bracket to the door. The glass can be removed. Reassembly in reverse order.

Spider

- CT3010X Complete Assembly of Spider
- CT3006 Spider Fringe
- CT4001 Spider Legs (6 per game)
- CT3010A Suction Cup Nipple (white)
- CT3010B Pump (green)
- CT3010C Valve (yellow)
- CT3010D Cable Retractable (white)
- CT3010E Spider Body Spine
- CT3010F Spider Body Shell w/ Leg holes
- CT3010G Spider Shell no holes
- CT3010H Threaded Metal Tube (Vacuum side)
- CT3010J Threaded Metal Tube (Rope side)

Wagon

- CT1055X Wagon Assembly
- CT1053 Brass Gear (wagon)
- CT3031 Drive Wheel (wagon)
- CT2009 Motor (up/down for rope)

Carriage

- CT1061 (Crane) Unmodified
- CT2008 Motor used in wagon and carriage
- CT3030 Drive Wheels (carriage)
- CT4002 Rubber Grommet (black) used for drive wheels on wagon and carriage
- CT4003 Rubber Drive Belt (red)
- CT3032 Worm Drive Gear (wagon and carriage)
- CT1052 Brass Gear (carriage)

Electronics

- CT8422 Microswitch
- CT2004 Joystick
- CT2005 Button with Switch
- CT2032 Display pcba
- CT2034 Main board
- CT2039R Receiver Prize Sensor
- CT2039T Transmitter Prize Sensor
- 2133CTL Controller for chasing rope light

Graphics

PART#	DESCRIPTION	#PER GAME
CT3000	Control Panel Display Filter	1
CT7000	Cabinet Side	2
CT7001	Prize Door	1
CT7002	Cabinet Front	1
CT7003	Candy Chart	1
CT7004	Instructions	1
CT7005	Spider Eyes	1
CT7006	Button Decal	1
CT7007	Mirror	1
CT7008	Motor Cover	2
CT7011	Control Panel Front	1
CT7012	Control Panel	1
CT7026	Side marquee	2
CT7027	Upper Marquee	1
CT7028	Front/LowerMarquee	1
CT7040	Programming Buttons	1
CT7031	"Harnessing ""Button"""	1
CT7032	"Harnessing ""Bill"""	1
CT7033	"Harnessing ""Coin"""	1
CT7034	"Harnessing ""Speaker"""	1
CT7035	"Harnessing ""Motor-Solenoid"""	1
CT7036	"Harnessing ""MF-SW"""	1
CT7037	"Harnessing ""Display"""	1
CT7038	"Harnessing ""Sub_Exit"""	1
CT7039	"Harnessing ""Main Board Power"""	1
CT7041	Kit - T-shirt Decal	6
CT7041	Kit - Cut the Rope logo	6



WARRANTY POLICY

I.C.E. Inc warrants all components in new machines to be free of defects in materials and workmanship for the period listed below:

- 180 days on Main PCB's, Computers & Motors
- 1 year on all LCD monitor panels
- 90 days on all other electronic and mechanical components
- 30 days on all I.C.E. repairs and parts purchases

I.C.E. Inc shall not be obligated to furnish a warranty request under the following conditions:

- Equipment or parts have failed through normal wear and tear
- Equipment has been subjected to unwarranted stress, abuse or neglect
- Equipment has been damaged as a result of arbitrary repair/modification

Products will only be covered under warranty by obtaining an I.C.E. authorized RMA #. To obtain an RMA # please provide I.C.E. tech support with the game serial # or original I.C.E. invoice # and a detailed description of the failure or fault symptoms.

I.C.E. Inc will assume no liability whatsoever for costs associated with labor or travel time to replace defective parts. All defective warranty covered components will be replaced with new or factory refurbished components equal to OEM specifications.

I.C.E. Inc will cover domestic UPS ground, or comparable shipping costs during the warranty period. International or expedited shipments are available for an additional charge. To obtain credit defective parts must be returned to I.C.E. Inc, at the customer's expense, within 30 days. After 30 days a 15% re-stocking fee will apply to all returns.

ICE distributors are independent, privately owned and operated. In their judgment, they may sell parts and/or accessories other than those manufactured by I.C.E. Inc. We cannot be responsible for the quality, suitability or safety of any non-I.C.E. part or modification (including labor) that is performed by such a distributor.

Innovative Concepts in Entertainment
10123 Main St.
Clarence, NY 14031
Phone #: (716) - 759 - 0360
Fax #: (716) - 759 - 0884
www.icegame.com