

# Installing the Sun Noise Reduction Kit

---

This chapter describes how to install the Sun noise reduction kit in a Sun Ultra 30 or Sun Ultra 60 workstation. The installation procedure illustrates the procedure with an Ultra 60 system, but installation is the same for both systems.

Installing the noise reduction kit involves the following steps.

---

**Note** – The procedures described here apply to both the Sun Ultra 30 and Ultra 60 workstations. Some steps, called out in the procedure description, are covered in more detail in the two systems' respective service manuals; Sun Ultra 30 Service Manual, 802-7719, or Sun Ultra 60 Service Manual, 805-1709.

---

1. Removing the power supply from the system chassis.
2. Removing the Removable Media Assembly from the system chassis.
3. Installing the noise reduction kit inside the chassis
4. Routing the noise reduction kit wiring inside the chassis and making all required connections.
5. Replacing the Removable Media Assembly into the system.
6. Replacing the power supply into the system.

---

## 1.1 Removing the Power Supply

**1. Power off the system unit.**

Refer to your system's service manual.

**2. Remove the side access cover.**

Refer to your system's service manual.

---

**Caution** – When removing the power supply, attach the copper end of the wrist strap to the system unit chassis, not the power supply.

---

**3. Disconnect the power cord from the power supply.**

**4. Attach the wrist strap.**

Refer to your system's service manual.

**5. Remove the power supply as follows (FIGURE 1-1):**

- a. **Using a number 2 Phillips-head screwdriver, loosen the four captive screws securing the power supply to the chassis.**
- b. **Slide the power supply from the chassis rear until the power supply is stopped by the power supply cables.**
- c. **Disconnect the peripheral cable connector from the power supply (not illustrated).**
- d. **Disconnect the power supply cables from the motherboard (not illustrated).**
- e. **Remove the power supply from the chassis.**

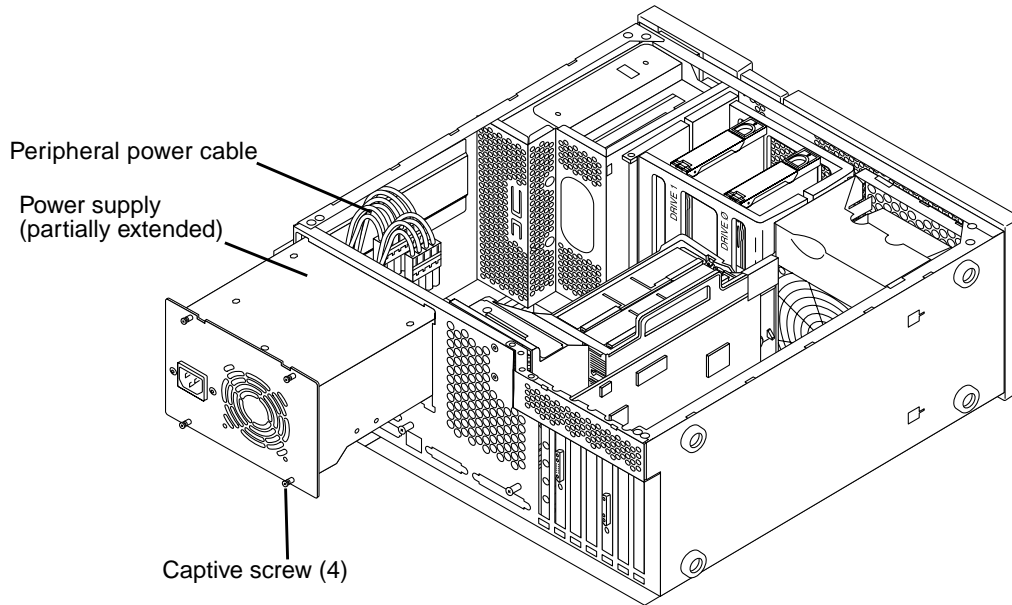
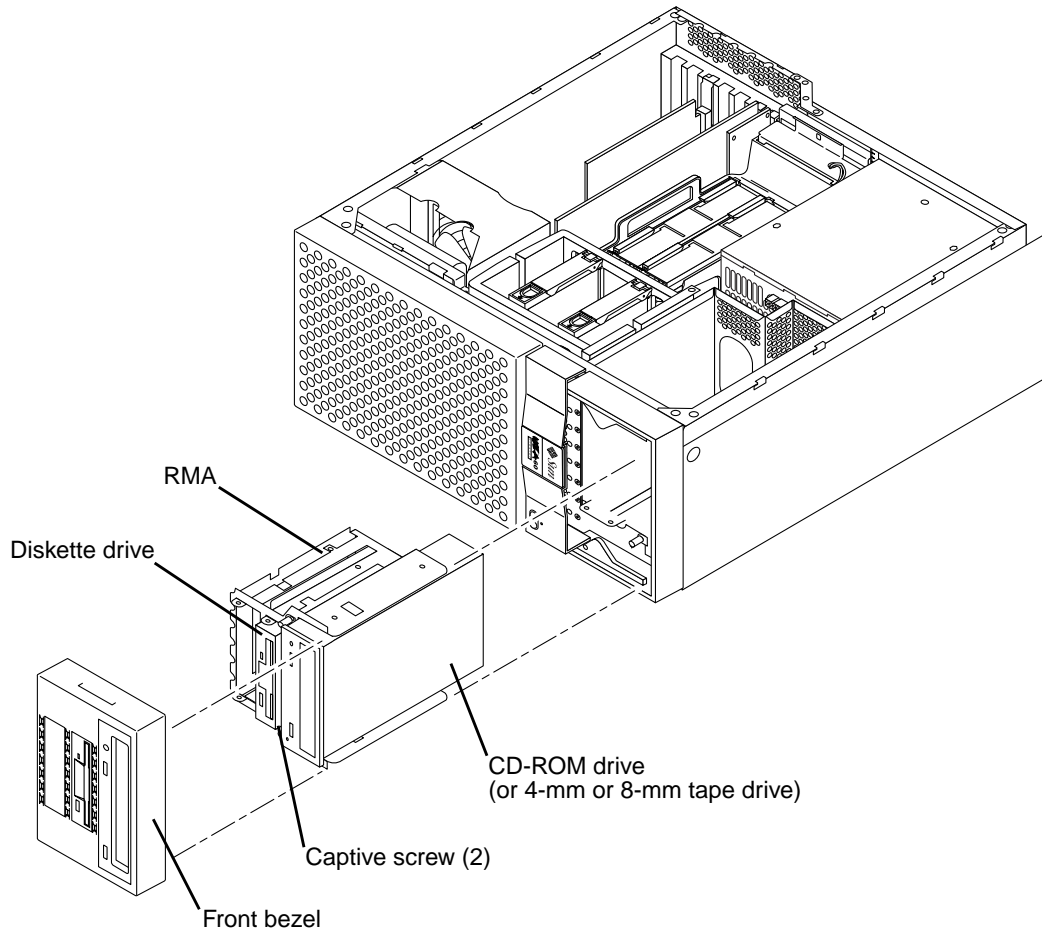

FIGURE 1-1 Removing the Power Supply

---

## 1.2 Removing the Removable Media Assembly (RMA)

1. Remove the RMA as follows (FIGURE 1-2):
  - a. Remove the front bezel.
  - b. Using a number 2 Phillips-head screwdriver, loosen the captive screws securing the RMA to the chassis.
  - c. Partially remove the RMA from the chassis.
  - d. Disconnect the peripheral cables and the power cables from the drives (not illustrated).
  - e. Remove the RMA from the chassis.
2. Place the RMA on an antistatic mat.



**FIGURE 1-2** Removing the Removable Media Assembly

---

## 1.3 Installing the Noise Reduction Kit

The noise reduction kit consists of the following parts, as shown in FIGURE 1-3:

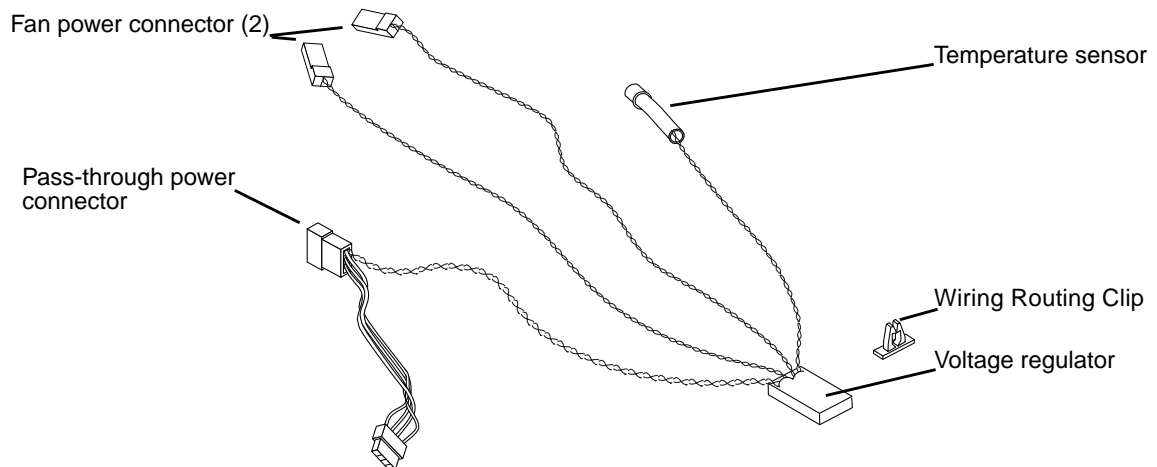
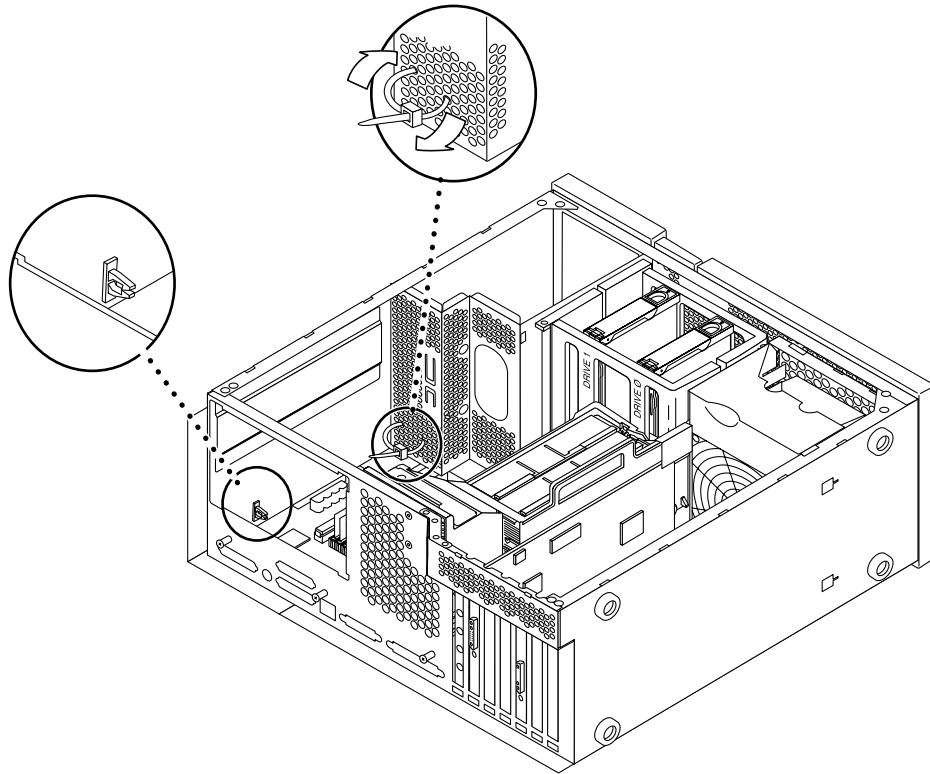

FIGURE 1-3 Noise Reduction Kit Components

1. Insert the nylon tie wrap in the system internal chassis as shown in FIGURE 1-4.
  - a. Route the tie, tapered end pointing down, through two holes in the internal chassis.
  - b. Slip the tapered end of the tie into the tie wrap lock.
2. Install the wiring routing clip inside the chassis, as shown in FIGURE 1-4.
  - a. Peel off the paper backing from the clip.
  - b. Press the adhesive back of the clip on to the top of the chassis as shown.



**FIGURE 1-4** Placing the Nylon Tie Wrap and Wiring Routing Clip

**3. Attach the voltage regulator, as shown in FIGURE 1-5.**

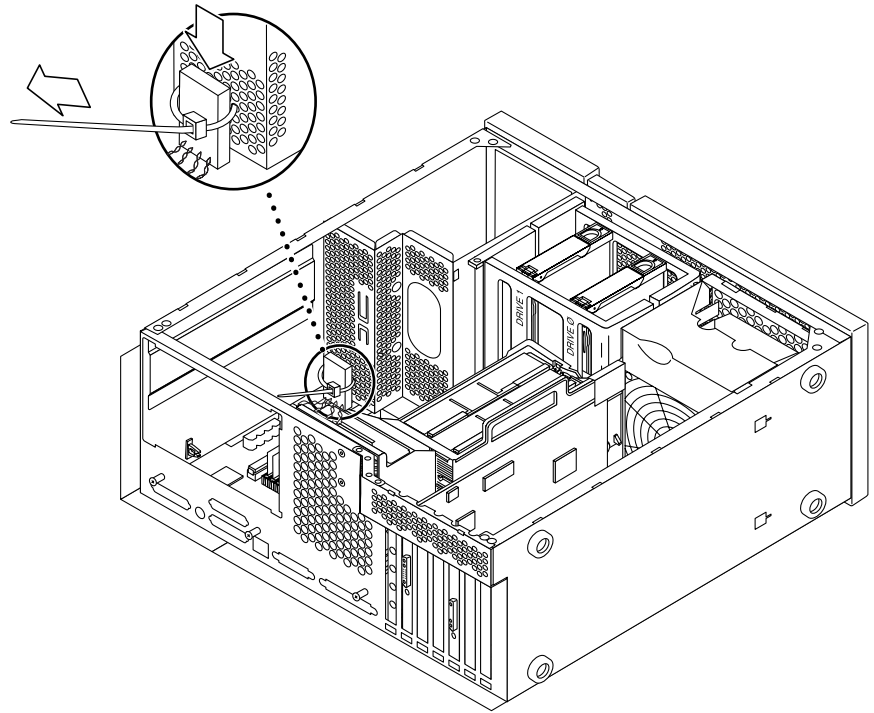

**FIGURE 1-5** Attaching the Voltage Regulator

- a. Slip the voltage regulator inside the tie wrap loop.**
- b. Tighten the tie wrap firmly to hold the voltage regulator in place.**

4. Route the temperature sensor and one of the fan power connector leads through the wiring routing clip and inside the chassis, as shown in FIGURE 1-6.

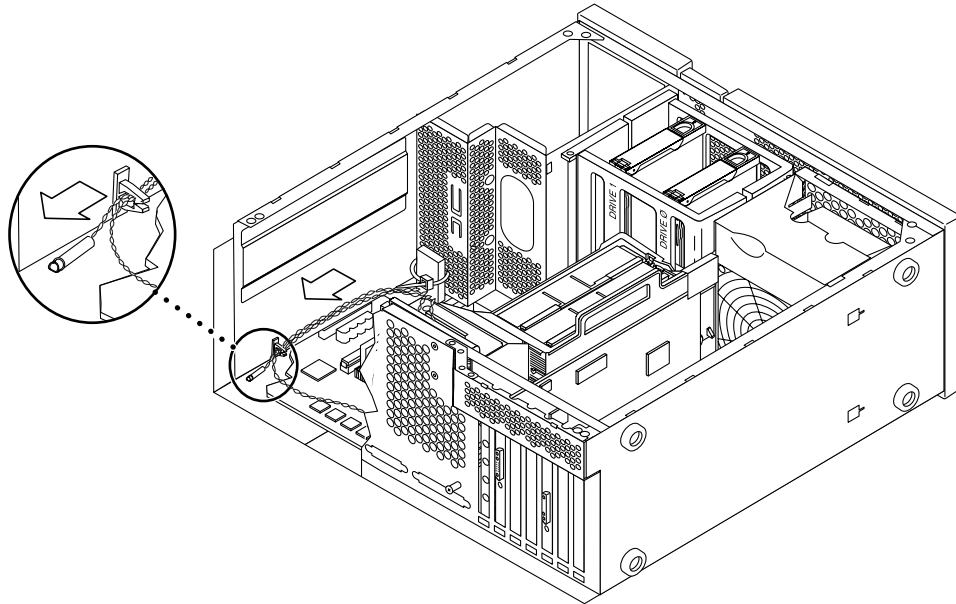
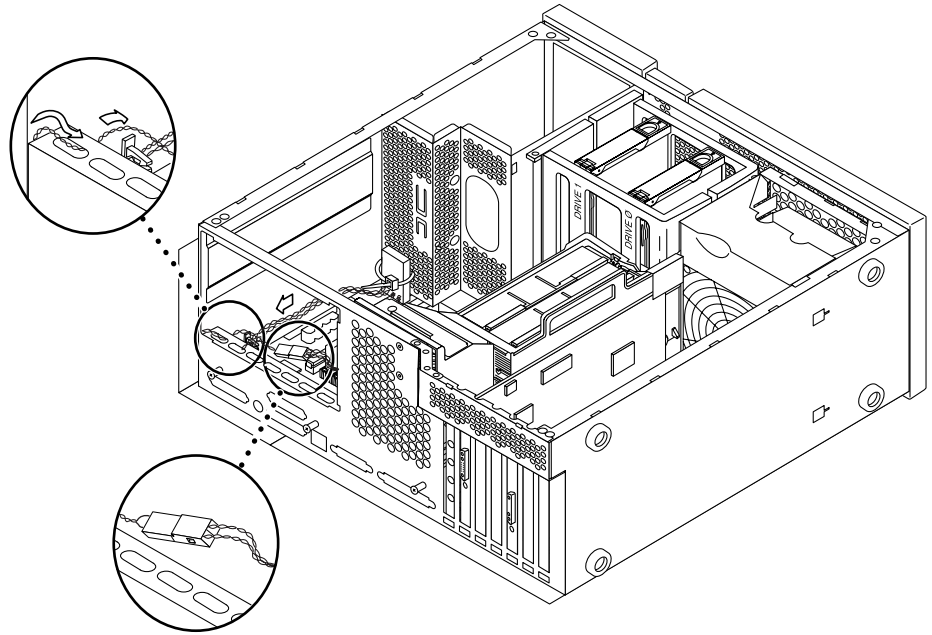

**FIGURE 1-6** Routing the Temperature Sensor and Fan Power Lead

5. Place the temperature sensor along the top of the system motherboard.



6. Route the fan power connector lead through the large holes in the chassis as shown in FIGURE 1-7.



**FIGURE 1-7** Routing the Rear Fan Power Connector Lead

Disconnect the rear CPU fan power cable from the system motherboard and connect it to the voltage regulator fan power lead connector.

7. Route the second voltage regulator fan power lead through the systems chassis as shown in FIGURE 1-8.

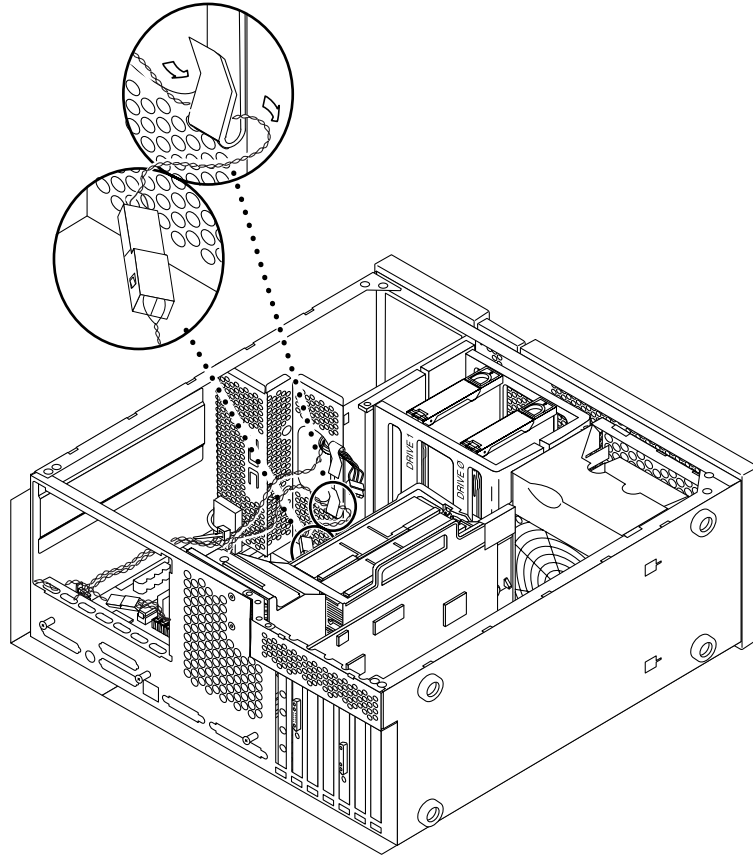

**FIGURE 1-8** Routing the Front Fan Power Connector Lead

Disconnect the front CPU fan power cable from the motherboard and connect it to the voltage regulator fan power lead connector.

8. Connect the female connector of the voltage regulator power pass-through connector to the SCSI device power connector labeled “P3” as shown in FIGURE 1-9.

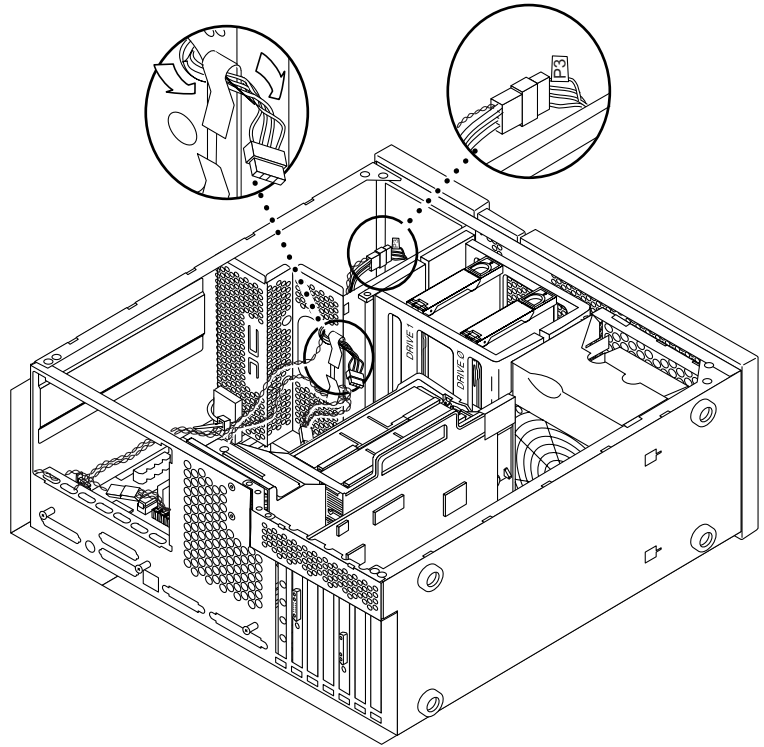

**FIGURE 1-9** Connecting the Pass-Through Power Connector

---

**Note** – You will connect the male connector of the voltage regulator power pass-through connector to the SCSI device in the RMA, if one is installed.

---

You have finished installing the noise reduction kit.

---

## 1.4 Replacing the RMA

---

**Caution** – Use proper ESD grounding techniques when handling components. Wear an antistatic wrist strap and use an ESD-protected mat. Store ESD-sensitive components in antistatic bags before placing them on any surface.

---

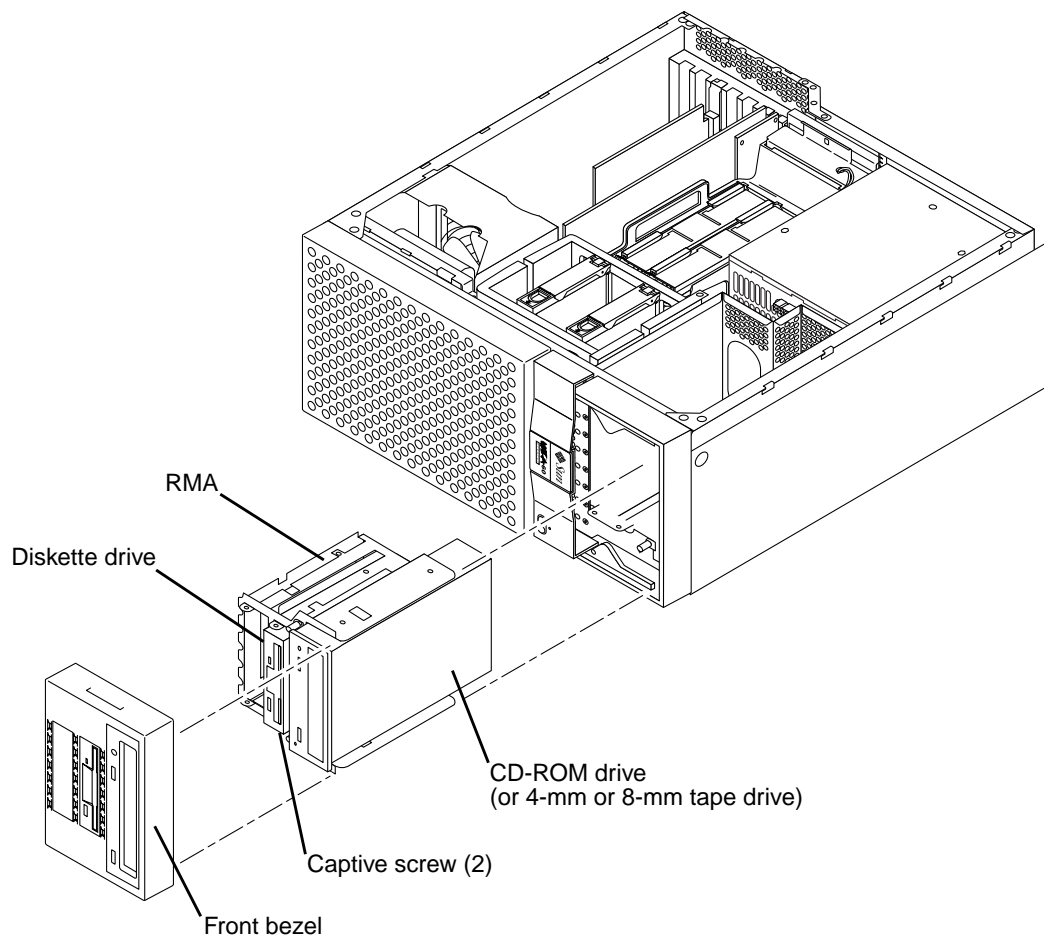

**FIGURE 1-10** Replacing the Removable Media Assembly

- 1. Replace the RMA as follows (FIGURE 1-10):**

- a. Position the RMA into the chassis, connect the rear cable connectors as required.
  - b. Using a number 2 Phillips-head screwdriver, tighten the captive screws securing the RMA to the chassis.
2. Replace the front bezel.

---

## 1.5 Replacing the Power Supply

---

**Caution** – Use proper ESD grounding techniques when handling components. Wear an antistatic wrist strap and use an ESD-protected mat. Store ESD-sensitive components in antistatic bags before placing them on any surface.

---

1. Replace the power supply as follows (FIGURE 1-11):
  - a. Feed the power supply cables through the chassis opening; support the power supply cables while engaging the power supply into the chassis rails.
  - b. Position the power supply into the chassis.
  - c. Slide the power supply toward the chassis front.
  - d. Connect the power cables to the motherboard.
  - e. Connect the peripheral cable connector to the power supply.
  - f. Replace the peripheral power cable through the cable routing clips.

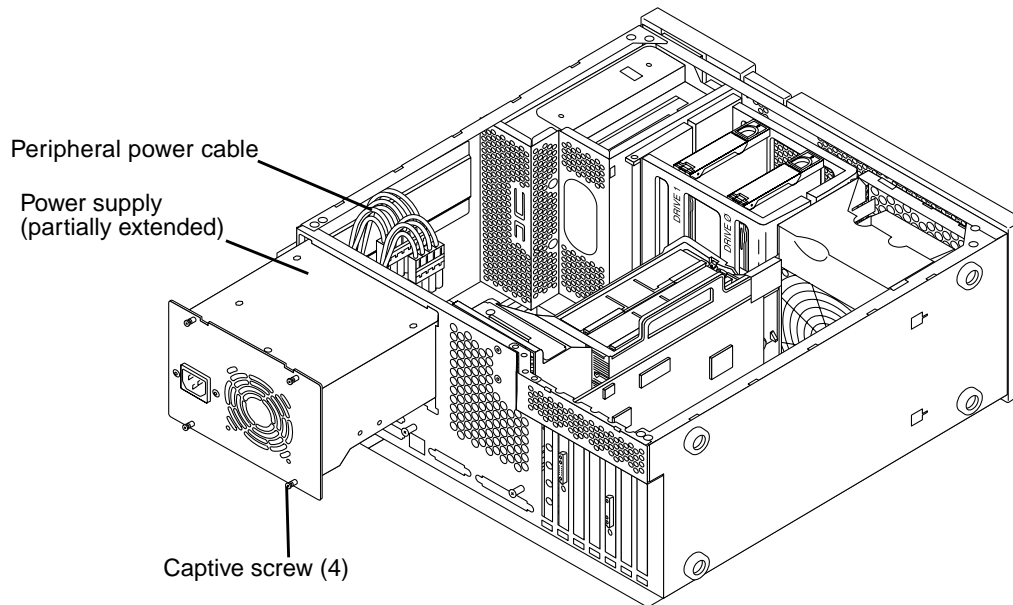

FIGURE 1-11 Replacing the Power Supply

- g. Slide the power supply toward the chassis front until the power supply rear panel is flush with the chassis.**
- h. Using a number 2 Phillips-head screwdriver, tighten the captive screws securing the power supply to the chassis.**

---

**Note** – Tighten the captive screws in a clockwise order beginning with the upper right captive screw.

---

- 2. Detach the wrist strap.**
- 3. Connect the AC power cord.**
- 4. Replace the side access cover.**  
Refer to your system's service manual.
- 5. Power on the system unit.**  
Refer to your system's service manual.