

Anchorage Amateur Radio Club

Next Meeting April 1st

April Program

"I did, I did, I did the Iditarod Trail"

By: Jesse L. Jones, KL1RK

As the famous song goes, "I did the Iditarod Trail." Now that the fun and excitement is over, it's time to get back to business! There are many stories and even more pictures to be shared from the trail. Be sure to attend the April General Membership Meeting as we share the adventures from stormy weather to runaway dog teams that make the Iditarod so much fun.



Jesse, KL1RK, before the Iditarod.
+++++



KL4E Works the A0-51 from his Roof

The picture on the address page is Craig Bledsoe, KL4E, working a morning pass of AO-51 from Eagle River, Alaska (Grid Square BP51) on a balmy day in February. FYI the Persian bathrobe, which could be a prop in "The Amazing

Technicolor Dreamcoat" is good for at least a 6dB path gain while working any of the FM LEO satellites. The rabbit fur hat from Costco and the classic Moon Boots from a garage sale in Fairbanks complete the ensemble.

The location is four stories up on the home QTH rooftop on the Eagle River hillside. The rig is an Icom W31 running full-duplex with an Icom VOX-operated headset into a split-boom Arrow. This exact configuration has provided satellite WAS for several Lower 48 amateurs, as well as working Canada, Russia, and Hawaii.



THREE MONTHS TO FIELD DAY

Set-up is on Friday evening, June 24th. We are hoping to get Kincaid Park again (same location as last year). The HF "competition" begins Saturday morning, June 25th at 1000 (local), running 24 hours until Sunday, June 26th at 1000 (local).

Field Day Rules are available on the ARRL website. This year the emphasis is on young operators and we can earn bonus points by using operators 18 years or younger.

Assuming Red Cross participation, we will again be operating Class 2F.

We are looking for "King Comms" for each bonus point category. All of these categories have a solid basis in emergency communications preparation:

The ??? means a volunteer is needed to take responsibility for that position. editor

The All-Important Infrared Station: ???

This is the food station -- although no "official" bonus points are awarded for this station, the world as we know it will collapse without them!

1. Young Operators: ???

20 points per valid contact initiated by an operator 18 years or younger, for a maximum of 100 points (assuming five operators).

2. Emergency Power, SSB: ???

100 points for putting the SSB station on-the-air using generator power, plus one point for each QSO.

3. Emergency Power, CW / Digital: ???

100 points for putting the CW / Digital station on-the-air using generator power, plus two points for each QSO.

4. GOTA maximum achieved: ???

A 100-point bonus may be claimed by a group whose Get-On-The-Air (GOTA) station completes a minimum of 100 QSO's. Up to 400 of the GOTA station QSO's may be counted for credit by the main station.

5. W1AW Bulletin, SSB: ???

33-1/3 bonus points for copying the special Field Day bulletin transmitted by W1AW during its operating schedule.

6. W1AW Bulletin, CW: ???

33-1/3 bonus points for copying the special Field Day bulletin transmitted by W1AW during its operating schedule.

7. W1AW Bulletin, Digital: ???

33-1/3 bonus points for copying the special Field Day bulletin transmitted by W1AW during its operating schedule.

8. Satellite QSO: ???

100 bonus points for successfully completing at least one QSO via an amateur radio satellite during the Field Day period.

9. Alternative Power: ???

100 bonus points for Field Day groups making a minimum of five QSO's without using power from commercial mains or a petroleum driven generator. This means an "alternate" energy source of power, such as solar, wind, methane or water, and includes batteries charged by natural means (not dry cells).

10. Non-Traditional Mode Demonstration No. 1: ???

100 points for each demonstration (up to three) for setting up a demonstration of a non-traditional mode of amateur radio communications. This includes modes such as APRS, ATV, and SSTV.

11. Non-Traditional Mode Demonstration No. 2: ???

100 points for each demonstration (up to three) for setting up a demonstration of a non-traditional mode of amateur radio communications. This includes modes such as APRS, ATV, and SSTV.

12. Non-Traditional Mode Demonstration No. 3: ???

100 points for each demonstration (up to three) for setting up a demonstration of a non-traditional mode of amateur radio communications. This includes modes such as APRS, ATV, and SSTV.

13. Message Origination to Section Manager: ???

100 bonus points for origination of a National Traffic System (NTS) style formal message to the ARRL Section Manager or Section Emergency Coordinator by your group from its site.

14. Message Handling: ???

10 points for each formal NTS style message originated, relayed or received and delivered during the Field Day period, up to a maximum of 100 points (ten messages).

Properly serviced copies of each message must be included with the Field Day report.

15. Site Visitation by an elected governmental official: Jim Larsen, AL7FS

A 100-point bonus may be claimed if an elected government official visits your Field Day site as the result of an invitation issued by your group.

16. Site Visitation by a representative of an agency: ???

A 100-point bonus may be claimed if your Field Day site is visited by a representative of an agency served by ARES in your local community (Red Cross, Salvation Army, local Emergency Management, law enforcement, etc) as the result of an invitation issued by your group.

17. Media Publicity: ???

100 bonus points may be earned for attempting to obtain publicity from the local media.

18. Public Information Table: ???

100 bonus points for a Public Information Table at the Field Day site. The purpose is to make appropriate handouts and information available to the visiting public at the site.

19. Public Location: Keith Clark, KL7MM / TJ Sheffield, KL7TS

100 bonus points for physically locating the Field Day operation in a public place (shopping center, community park, school campus, etc). The intent is for amateur radio to be on display to the public.

Bonus points available: 1,700

Individual commitment: 200
Percent complete: 12 %

FIELD DAY CO-CHAIRMEN

Keith Clark – KL7MM: aksunlite at aol.com
HM: 243-0706
WK: 277-3545

TJ Sheffield – KL7TS: kl7ts at arrl.net
HM: 248-3864
WK: 265-2409

+++++

Alaska QRP Club meets the Third Friday of every month – 7:00 PM (Some show for dinner at 6PM): Hams with QRP (low power under 5 watts) and Homebrewing interests meet for a social meeting monthly. Meet at Dennys (in the back room) on DeBarr near Bragaw. Contact is Jim Larsen, AL7FS, [JimLarsen2002 at alaska.net](mailto:JimLarsen2002@alaska.net) or 345-3190.

A Ham Named Sid
By Mike Wood, KL1RO

This is the story,
Of ham named Sid,
Who thought it was fun,
To be a big Lid.

He would giggle and laugh,
He would chuckle with glee,
When he gave other hams,
Great misery.

He caused QRM,
The rules he was mocking,
Then one day,
The FCC came a knocking.

He started to moan,
He started to whine,
He started to cry,
When he saw the fine.

"You cannot do this!",
Said Sid in defiance,
"It is my right!",
"I have a license!"

He would not pay,
He told them to stick it,
Then the FCC said,
"Give us your ticket."

They took his ticket,
And all his money,
Just because he thought,
Being a Lid was funny.

So take this advice,
And learn from old Sid,
When you get on the air,
Don't be a Lid.



KL7AA Mail Reflector

If you like to stay in touch on KL7AA news and other posts of local interest.

Step #1: First point your browser to (click the link below):
<http://mailman.qth.net/mailman/listinfo/kl7aa>

Step #2: On the web page you will see a section titled "Subscribing to KL7AA". Enter your e-mail address in the "Your email address" entry box.

Step #3: Pick a password for your account and enter it in the box marked "Pick a password" and then enter the same password in the box marked "Reenter password to confirm". This password will be used to change your settings on the list

such as digest mode, etc.

Step #4: If you would like the e-mails in daily digest form click yes on the line marked "Would you like to receive list mail batched in a daily digest?"

Step #5: Click on the "Subscribe" button below the information that you just entered.

Alaska CW Net (ACWN)



Alaska CW Net (ACWN) still maintains a daily traffic watch on 3540 7042 and 14050 Khz....from Fairbanks. ACWN is a registered ARRL Section Net in Alaska.

Starting at about 0100Z every evening, AL7N in Fairbanks **maintains traffic watch** simultaneously and as continuously as possible on all three frequencies, until the following morning about 1600Z. Also guards 2 meters 144.100 Mhz (CW mode) in Fairbanks area.

Weekends, monitor continuously whenever in the house where can hear the speakers, day and night.

Saturday schedules with K6KPH on 14050 at or after 1800Z, whenever we can get thru depending on 20 meter band condx and contest QRM. K6KPH is relay to lower 48 NTS; closes down about 0100Z.

ACWN encourages other operators around the state of Alaska to participate and will gladly exchange WX and signal reports if nothing else...just to keep the pipe open. Will handle legal 3rd party written traffic to anywhere, even to e-mail addresses if specified. Working CW speed is regulated to suit the operator receiving...

If other nets have traffic they can't move, send 'em down to ACWN! "Listeners" on the ACWN watch frequencies probably won't hear anything unless they call with traffic or just call for a signal check/report which will be gladly supplied to anyone if we can hear 'em at all.

Ed Trump, AL7N ACWN Net Manager

FOR SALE

Icom-735 transceiver, External matching speaker, PS-55 Power Supply, AT-150 External Automatic Antenna Tuner. Additionally, radio has the optional narrow CW and AM filters installed. Price is \$400 cash, firm, no trades. It's all in just-out-of-box condition. Manuals included (including service manual for the 735)

Contact Frank, KL7RX at 333-8212

FCC Morse, Restructuring proposals could be out by mid-year

ARRL Bulletin 8 ARLB008

The FCC continues to work toward developing a Notice of Proposed Rule Making (NPRM) that will spell out what the Commission has in mind with respect to possible changes in the current Morse code requirement and Amateur Radio licensing.

A total of 18 petitions have been filed, including one from the ARRL, seeking Part 97 rule changes addressing the future of the 5 WPM Morse requirement (Element 1) and revisions to the overall Amateur Radio licensing structure. The FCC plans to tackle all 18 in a single proceeding.

On the code issue, petitions--and comments in response to them--run the gamut from retaining or even beefing up the Morse requirement to eliminating it altogether. (The ARRL's proposal would retain the 5 WPM Morse examination for Amateur Extra class applicants only.)

The League and others have also put forth proposals for a new entry-level Amateur Radio license class. At this point, personnel in the FCC Wireless Telecommunications Bureau are continuing to review the thousands of comments filed on the 18 petitions.

While the FCC appears unlikely to release an NPRM any sooner than mid-year, the issue still may be a major discussion topic during the FCC Forum at Dayton Hamvention, May 20-22.

Once public, the NPRM would initiate another round of public comments on what the FCC has proposed. An FCC Report and Order implementing any new rules is unlikely before the second half of 2006, although it's possible the Commission could wrap up the proceeding before then.

An Inexpensive Computer/Radio Interface For Icom Radios By Mike Wood, KL1RO

My HF rig is an Icom IC-725. It is a nice no frills radio and has allowed me to get my feet wet in the HF spectrum for a rather low startup cost. One thing I have been wanting is an interface so I can hook up the 725 to my computer. This will allow me to use rig control software as well as use features in many of the logging software titles that I have been unable to take advantage of.

Icom offers an interface unit, the CI-V, for their line of radios. Only problem is that it is one expensive little gadget! Holding true to my Scottish ancestry, I am way too cheap to buy a CI-V. The alternative is to build one for a fraction of the price.

My quest lead to several designs available on the Internet as well as the one in the ARRL Handbook. I have never built something straight from a schematic before, so simplicity was

very important to me. The fewer parts needed to build the interface, the fewer parts I could mess up. I settled on a design found on the web site of G3VGR, who took a design from OK2WY and modified it slightly. It is simple, uses few parts, and should be a good starter project for a beginner like myself.

After acquiring an enclosure (\$3.99), a 9 pin serial socket salvaged from an old computer, and the parts (Thank you KL7CC!) I was off in my building adventure.

Icom CI-V Interface

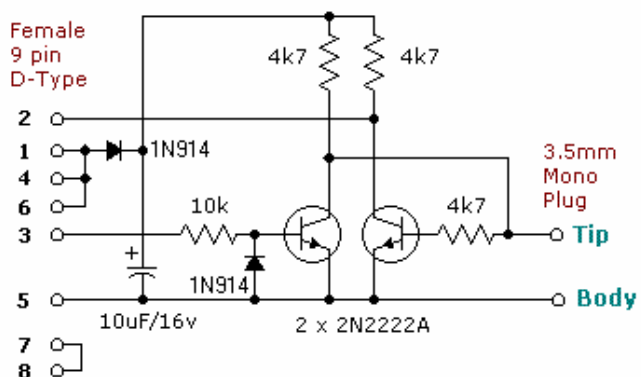

Additional Circuitry to provide PTT from RTS

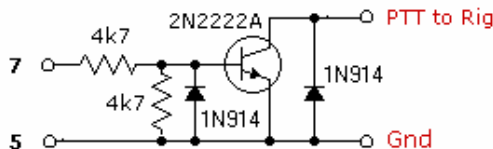

Construction was pretty easy. The enclosure I purchased came with the copper clad board included. All I did was solder the parts on the board and then used some hookup wire to join the leads according to the schematic. I drilled out a hole for the serial socket and a 1/8 phono jack I salvaged from an old tape recorder. The tricky part was attaching the completed circuit to the serial socket pins. My chubby little fingers had a time of it getting them all hooked up.

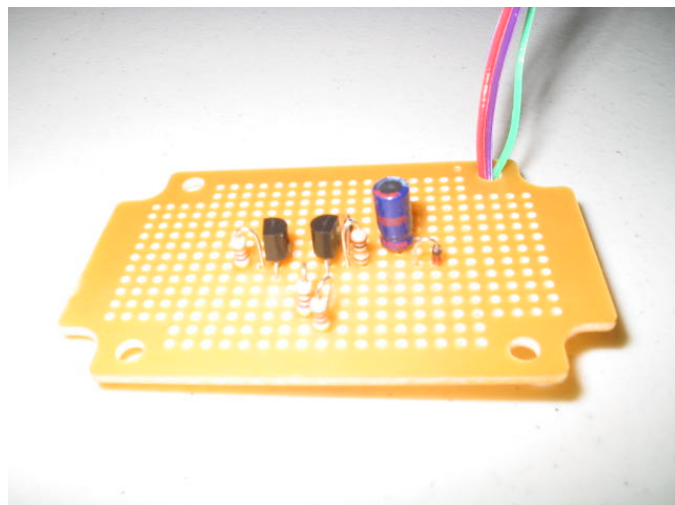

Once the unit was assembled and ready to go, I decided to test it before I put it all in the enclosure. It did not work on the first try. Careful examination revealed that I had mixed 2 of the pins while hooking up the serial plug. Fixed that problem, but it still would not work. Going through the circuit very carefully I discovered a solder bridge that I had missed during my final check. Three minutes later the error was fixed and the unit was working! My radio is now hooked up to my computer for fewer than 10 bucks. That is pretty hard to beat. I have tried the interface with Ham Radio Deluxe and Logger32 software and both function very well. The only problem I encountered was setting the hex address properly. For my rig the correct hex address is 28. Check your rigs manual.



If you have an Icom HF radio that is compatible with the CI-V interface, you may want to give this little project a try. It is a fun way to spend an evening and you will add to the capabilities of your rig at the same time.

Link to G3VGR's website:

<http://www.qsl.net/g3vgr/civ.html>

Mike Wood, KL1RO



ARES Contact Information

District Emergency Coordinator:
Position Vacant

Additional information on ARES can be found at the following URL:

<http://www.qsl.net/aresalaska/>

News from the Yukon

Hi, name is Ron, VY1RM, VP Yukon Amateur Radio Association. I've been asked to be the frequency co-ordinator for the Yukon for Amateur radio, I'm also an assistant director for Radio Amateurs of Canada, for BC, Yukon, (Similar to ARRL)

If people from your club are coming out way please ask them to e-mail me for the latest updates on what repeaters are working or may be down for repair.

We have 11 repeaters linked together along with IRLP and Echo Link.

Echo-Link and IRLP are on in Whitehorse but on 58 simplex for now.

We are in the process of building two separate repeaters for the VoIP units and they will be on the air at Whitehorse, only

Anyway, Greeting from Whitehorse.

Ron McFadyen VY1RM
VP YARA
Whitehorse, Yukon, Canada
ron@ckrw.com



Become an active member of the Amateur Radio Emergency Service. Train with ARES. Earn your ARES membership badge for use during emergencies. Join ARES.

Building an Arrow Antenna for LEO

The attached files have all the information needed to build your own homebrew Arrow antenna for working the satellites, tracking critters, or any other conceivable purpose. You can also build a duplexer to use with your antenna. Happy Building. Craig Bledsoe, KL4E

If you would like to purchase parts to build the duplexer, you can get the capacitors and inductors using the following Digikey part numbers:

Panasonic SMT Capacitors: PCC2R7CCT-ND 2.7pF cap (2) \$1.60/10 PCC4R7CCT-ND 4.7pF cap (1) \$1.60/10 PCC180CCT-ND 18pF cap (2) \$1.60/10 Delevan SMT Inductors: DN08150CT-ND 15nH inductor (2) \$1.93 ea DN08680CT-ND 68nH inductor (2) \$1.93 ea DN08101CT-ND 100nH inductor (1) \$1.93 ea

Parts List:

2 4.7pF 5% 50V NPO 1206 or 0805 1 2.7pF 5% 50V NPO
 1206 or 0805 2 18pF 5% 50V NPO 1206 or 0805 2 15nH 5%
 650 mA 1008 2 68nH 5% 650 mA 1008 or 1210 1 100nH 5%
 650 mA 1008 or 1210

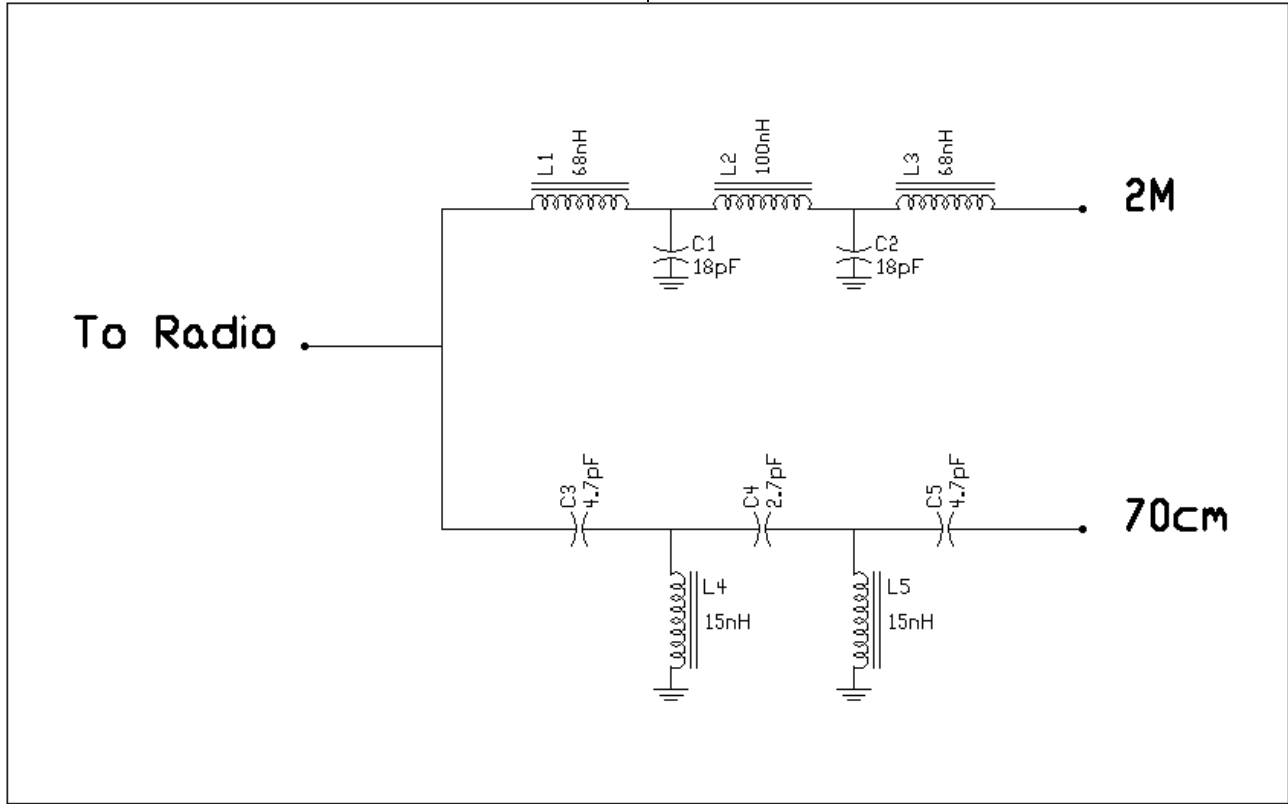
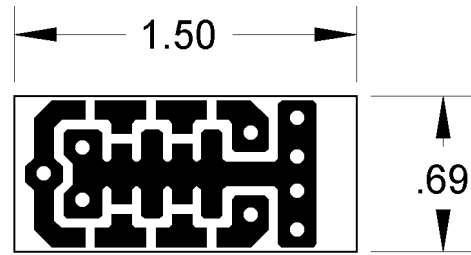

Model 10W (Low Power)
Duplexer for 146/437-10

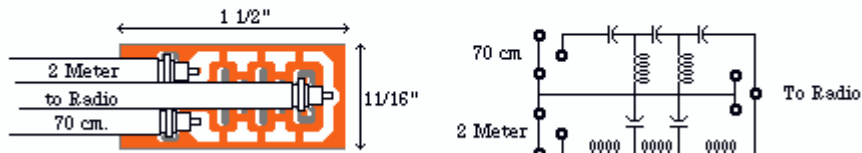

All Surface mount componets.

Max. Power is 10 Watts.

Duplexer fits inside the Boom,
 Coax is routed under Foam Grip

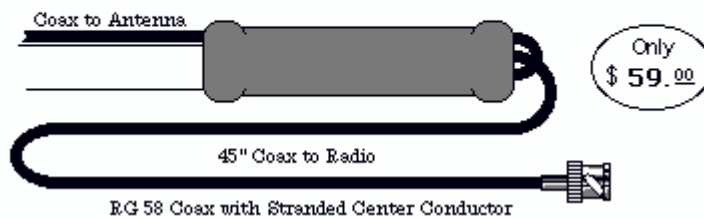

2 meter: Director=92.75cm Driven=97.5cm Reflector=102.5cm Dir-Dri=41.5cm Dri-Refl=41.5cm
 Gamma match: 20cm long and separation is 3.75cm Boom is approx. 130.0cm
70 cm: Reflector=34.26cm @ 00.00cm Driven=32.63cm@13.76cm Dir1=31.00cm @13.76cm
 Dir2=30.67cm@15.14cm Dir3=30.35cm @16.65cm Dir4=30.02cm @18.32cm Dir5=29.69cm @20.15cm
 Gamma length is 7.5cm and separation is 2.5cm

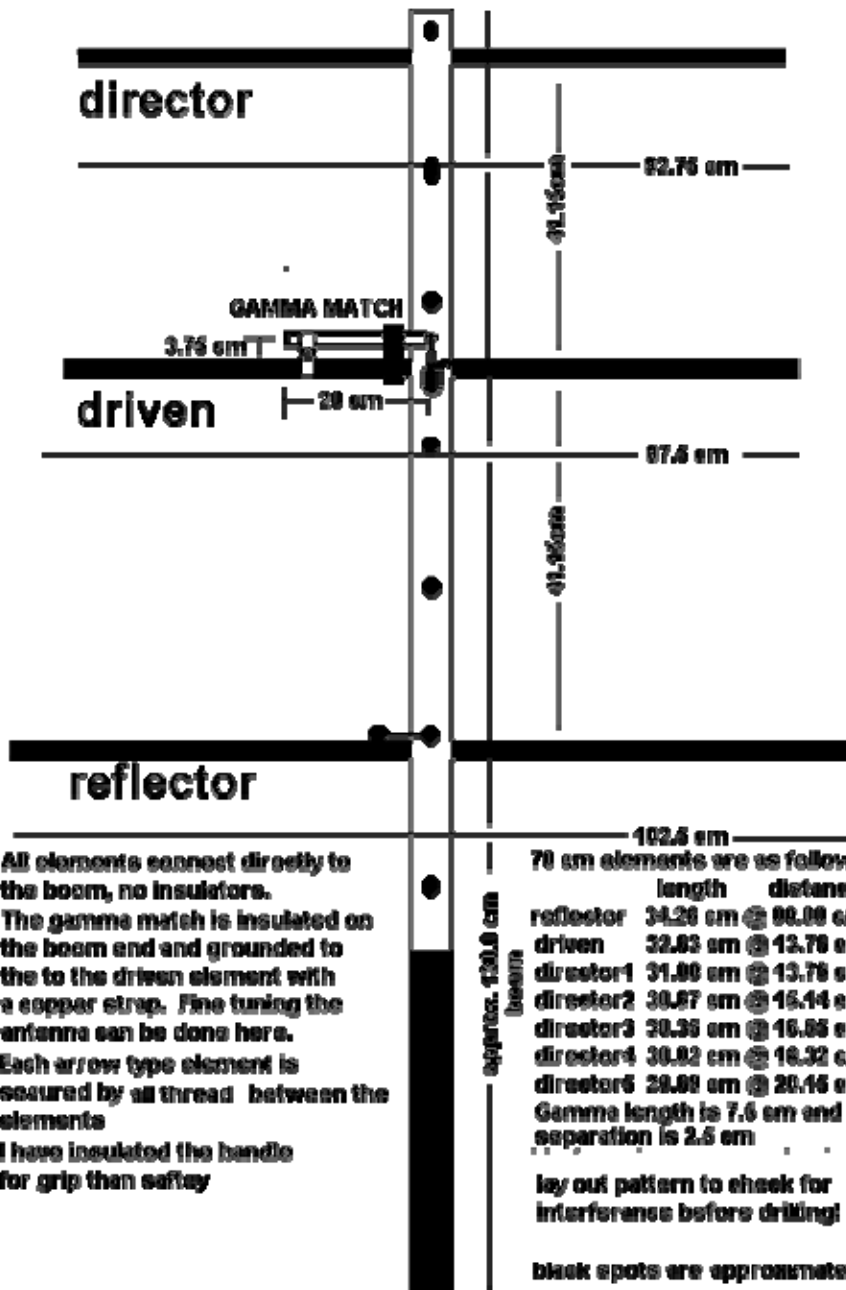

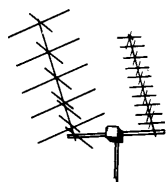

Interested in Satellites?

Check this out.

If you have any interest in Satellite work, Dan O'Barr, KL7DR, has put together a very nice site filled with useful links. I recommend you check it out at:

<http://gahleos.obarr.net/>

Dan's own [KL7DR's New LEO Primer](#) is there and it provides information on getting started in the Low Earth Orbit satellites. Many of you have seen Dan or Craig Bledsoe, KL4E, demonstrate their hand held antenna with HT at a club meeting or a field event. With their simple systems, they talk successfully through the satellites. Fun stuff. Check it out.

AL7FS

+++++

A BIG THANK YOU to

[The Anchorage Amateur Radio Club KL7AA \(AARC\)](#)

for letting us use their Communications Command Vehicle (CCV) as the Communications Command point for the **Re-Start of the 2005 Iditarod Trail Sled Dog Race**, in Willow March 6th.

By Dan O'Barr, KL7DR

<http://gahleos.obarr.net/>



A special thank you needs to go to **Mike O'Keefe, KL7MD** and **Bruce McCormick, KL7BM** for making the arrangements and bringing the CCV out to Willow from Anchorage. To keep everything running smoothly, Mike and Bruce along with myself, **Dan, KL7DR** ran five radio nets from the CCV for over eight hours continuously. To communicate with over 20 other Hams, we ran three Amateur Radio nets, with the 147.27 repeater used for our "Main Operations net" for emergency contact to the CCV, trail road crossings, and security. We also used 146.43 simplex for the Hams that worked as "official shadows" and 146.52 simplex

for the Hams that worked the main gate, Parks HWY road traffic, and parking.

A fourth radio net was run on an FRS channel to keep in contact with The Alaska State Defense Force that provided security at the Willow Airport, (State of Alaska property) and was off limits to the 10,000 plus spectators. **A fifth net was run on a commercial UHF radio system donated by Don Lederhos, KL1OZ of ARCTiCOM, to maintain constant contact with Deby Trosper, Iditarod Trail Committee Re-Start Coordinator.** We also had radio contact with The Alaska State Troopers and the local EMS group.

It's difficult for me to find the words to properly thank all those that contributed to this great effort, but here are some more I'd like to name:

- James Bardoner, KI4IWQ** as Deby's Shadow and Start Line Jenny Magee as Deby's Shadow
- Dakota Stuart, KL1ES** as Candy's Shadow
- Jim Bruton, KL7HJ** and son Grayson as Musher Parking, Shelly Betlej's Shadow
- David Gehring, KL1TN** as Race Marshall, Mark Nordman's Shadow
- Steve Gehring, NL7W** as Team Staging: Pat, Tracy, and Wendy's Shadow
- Steve Jensen, KL0VZ** as Team Staging: Pat, Tracy, and Wendy's Shadow
- Ray Hollenbeck, KL1IL** as Security Bill McCormick's Shadow
- Jim Wardman, N9RNL** as Security Lara Baker's Shadow
- Thalia Wood, KL1KM** as North Airport Parking and USAF Shadow
- Edward Moses, KL1KL** as South Airport Parking and USAF Shadow
- Tom Stuart, KL0QQ** as Main Gate, Cheryl Metiva's Shadow
- Luke Smith, KL7LK** as Trail Security by snowmobile and Richard Schwab's Shadow
- Wayne Groomer, KL7HHO** as Road crossing #1 Comms
- Gladys & George Meacock, KL7JB & NL7RD** as Road crossing #3 Comms
- Tim Comfort, NL7SK** as End of road -- Road crossing #5 Comms
- Don Lederhos, KL1OZ** donated UHF radio system
- Tanya Larrabee, KL1PY** Red Cross Comms
- Amanda Isakson, KC7MFV** Alaska State Defense Force Comms

+++++

Iditarod Special Events Station Corliss Kimmel – AL1G

I had a very successful Iditarod Special Event as KL7DX. Band conditions weren't the greatest, but I managed to make almost 800 contacts from around the world and the US. I worked a lot of Europe, Japan, States, South America and Caribbean. One highlight was getting a call from Martinique!

Many people that I talked to were following the progress of the Iditarod racers via newscasts and internet. Many people

asked about Rachael Scdoris, especially those calling from her home state in Oregon.

I spoke with someone whose brother was one of the volunteers helping Martin Buser. Another was a ham who comes up here to volunteer on the trail every other year. He said this was his off year and was very much looking forward to coming up for next year's race.

I spoke with a Canadian musher who runs races in Canada and dreams of running the Iditarod some day.

My qsl manager said that the mail on Tuesday after the special event there were 81 qsl requests.

All in all, it was a lot of fun!

Corliss - AL1G

Iditarod QSL:



+++++

Emergency Response Communicators (ERC) Net

The ERC Net is designed to help hams get on the air more often, stay familiar with their equipment, and get to know their fellow hams in the area so that they can work together better in an emergency. Check it out.

Sunday, 7:30PM on 147.27 Repeater (103.5 tone)

Sunday, 8:30PM on 3.880 MHz HF SSB

SB QST @ ARL \$ARLB007

ARLB007 Amateur Radio Spectrum Protection Act of 2005 Introduced

ZCZC AG07

QST de W1AW

ARRL Bulletin 7 ARLB007

>From ARRL Headquarters

Newington CT March 1, 2005

To all radio amateurs

SB QST ARL ARLB007

ARLB007 Amateur Radio Spectrum Protection Act of 2005 Introduced

At the urging of the ARRL, Rep Michael Bilirakis (R-FL) has introduced The Amateur Radio Spectrum Protection Act of 2005 into the US House of Representatives. The bill, designated HR 691, has been referred to the House Energy and Commerce Committee where Bilirakis serves as vice chairman. Like previous versions of the proposal, the current measure would require the FCC to provide "equivalent replacement spectrum" to Amateur Radio if the FCC reallocates primary amateur frequencies, reduces any secondary amateur allocations, or makes additional allocations within such bands that would substantially reduce their utility to amateurs.

ARRL President Jim Haynie, W5JBP, says the legislation "is vital for ensuring that the Amateur Radio Service, the only 100-percent fail safe emergency communication capability, remains a viable public safety option."

HR 691 references Amateur Radio's role in providing "voluntary, noncommercial radio service, particularly emergency communications," and it points out that hams have "consistently and reliably" provided communication support in the event of emergencies and disasters including tornadoes and hurricanes, chemical spills, forest fires and rail accidents. As the measure notes, FCC actions already have led to the loss of at least 107 MHz of spectrum to radio amateurs.

Rep Roscoe Bartlett (R-MD) has signed on as the bill's first co-sponsor.

Efforts now will focus on attracting additional cosponsors for the legislation. The League is encouraging members to urge their congressional representatives to sign aboard HR 691. More than 100 lawmakers agreed to cosponsor similar legislation in the 108th Congress, where it was designated HR 713. Work is proceeding to have identical legislation introduced in the US Senate. The text of HR 691 is available on the Government Printing Office Web site http://frwebgate.access.gpo.gov/cgi-bin/getdoc.cgi?dbname=109_cong_bills&docid=f:h691ih.txt.pdf.



Jesse Jones, KL1RK, doubling as checker at Safety Read Jesse's Iditarod Journal (after News You Can Use)



Data You Can Use:

Officers

President Jim Larsen, AL7FS jimlarsen2002 at alaska.net
Vice Pres. Judi Ramage, WL7DX damage at gci.net
Secretary Fielder George Dowding KL7FHX
Fgdowding at iceworm-enterprises.net
Treasurer Heather Hasper, KL7SP, kl7aa at adnmail.com
Trustee Jim Feaster, KL7KB
Activities Chairman Jesse Jones, KL1RK
kl1rk at yahoo.com
News Letter Editor Jim Larsen, AL7FS
Membership Chairman Fred Erickson KL7FE
frederickson at iname.com
Past-President Randy Vallee, KL7Z

Three Year Board Members

Jim Wiley, KL7CC jwiley at alaska.net
Richard Block, KL7RLB, rblock at arctic.net
Frank Pratt, KL7RX kl7rx at arrl.net

One Year Board Members

Steve Jensen - KL0VZ, jensens at acsalaska.net
Steve Gehring - NL7W, steveg at mtaonline.net
TJ Sheffield - KL7TS, kl7ts at hotmail.com

VACANT

Mike Wood - KL1RO, kl1ro at arrl.net
David Stevens - KL7EB, kl7eb at arrl.net
Carl London - N5XLI, carljondon at yahoo.com

AARC web page & Email contact addresses:

Homepage: <http://www.KL7AA.org/>
Webmaster: AL1G_ak (at) yahoo.com
President: JimLarsen2002 (at) alaska.net
Vice President: damage (at) gci.net
Membership: Frederickson (at) iname.com
Newsletter: JimLarsen2002 (at) alaska.net

News Letter Submissions, Information or corrections:

Submissions must be received 2 weeks before meeting
Email: JimLarsen2002 (at) alaska.net
Mail: 3445 Spinnaker Drive, Anchorage 99516

Nets in Alaska:

The following nets are active in South-central Alaska:
Alaska Sniper's Net 3.920 MHz 6:00 PM daily
Alaska Bush Net 7.093 MHz 8:00 PM daily
Alaska Motley Net 3.933 MHz 9:00 PM daily
Alaska Pacific Net 14.292 MHz 8:00 AM M-F
ACWN (Alaska CW Net) 3534, 7042 Daily @ 0700 –

1000, and 1900 - 2400 Alaska Time - AL7N or KL5T monitoring.

Net Purpose: Formal NTS traffic via CW.
No Name Net 146.85/.25 repeater Sundays 8:00 PM
Grandson of SSB Net 144.20 USB Mondays 8:00 PM local
Big City Simplex Net 146.520, 446.0, & 52.525 FM
With Packet 145.01 Tuesdays 8:00 PM local
ARES net 147.27/87 103.5Hz - Thursdays at 8:00 PM local
PARKA net 147.30/90 Thursdays at 7:00 PM local
ERC VHF Net 147.27/87 103.5Hz – Sunday 7:30 PM local
ERC HF Net 3.880 MHz – Sunday 8:30PM local

Any AARC sponsored repeater, with or without an auto-patch, will always be open to all licensed amateur radio operators in the area who are authorized to operate on those frequencies.

Anchorage & Mat Valley Area Repeaters-a/o Mar05

KL7AA systems at Flattop Mt., 2,200 ft
146.94/34 MHz, 80 watts, autopatch, 141.3 Hz PL
224.94/223.34, 25 watts, no patch, no PL
444.70/449.70, 25 watts, autopatch, 141.3 PL
****147.27/87 MHz, no patch, Mount Susitna 103.5 Hz**
****443.3/448.3, no patch, Mount Susitna 103.5 Hz**

KL7CC, Anchorage Hillside, SCRC & QCWA
146.97/.37 MHz, 30 watts, autopatch, 103.5 Hz PL
KL7M Anchorage Hillside
147.21/.81 MHz, on IRLP, 97.4 Hz PL
KL7ION at Mt. Gordon Lyon, PARKA 3,940 ft
147.30/90, MHz - 80 watts, no patch, 141.3 Hz PL

KL7AIR Elmendorf AFB, EARS
146.67/.07, 107.2 Hz PL
KL7JFU, KGB road, MARA club
146.85/.25, autopatch, no PL
KL7DOB, Alcantra (Wasilla Armory)
146.64/.04, simplex patch, no PL
KL7DJE at Grubstake Peak, 4,500 ft. <down >
147.09/.69 MHz, 25 watts, no patch, 100 Hz PL
444.925/449.925, 10 watts, no patch, 141.3 Hz PL

KL3K, Girdwood
146.76/16 MHz, 25 watts, no patch, 97.4 Hz PL

South Central Area Simplex Frequencies

146.52 MHz Calling and Emergency frequency
147.57 / 447.57 (crossband linked) HF spotters & chat, 103.5 HZ PL
146.49 MHz Anchorage area simplex chat
146.43 MHz Mat Valley simplex chat
147.42MHz Peninsula simplex chat

VE Testing in the Valley

Valley VE testing sessions will be held at the Wasilla Red Cross at 7 pm on the fourth Saturday of each month unless it is a major holiday weekend. The address is 262 E Nelson St in Wasilla. Nelson Street is the extension of Bogard to the west from Main Street/Wasilla Fishhook, and the Red Cross is on the south side of Nelson about halfway from Main to Lucille. (eff. 9.25.04)

Internet Links, the favorites from our readers:

QRP and Hombrew Links <http://www.AL7FS.us>

AARC <http://www.KL7AA.org/>

SCRC <http://www.KL7G.org>

EARS <http://www.qsl.net/kl7air>

MARA <http://www.kl7jfu.com/>

Moose Horn ARC <http://www.alaksa.net/~kl7fg>

ARES <http://www.qsl.net/aresalaska>

KL7J <http://www.alaska.net/~buchholz>

Fairbanks AARC: <http://www.kl7kc.com/>

Yukon Amateur Radio Association:

<http://www.klondike.com/yara/index.html>

HAARP Project:

Amateur Radio Reference Library

<http://www.area-ham.org/library/libindex.html>

Hamradio: <http://www.hamrad.com/>

Solar Terrestrial Activity <http://209.130.27.95/solar/>

ARRL <http://www.arrl.org/>

Propagation Report Recording 566-1819

Please let us know if there are other clubs pages or good starting points that should appear here. Report dead links or bad info to [JimLarsen2002 at alaska.net](mailto:JimLarsen2002@alaska.net).

+==+==+==+==+==+==+==+==+

NEWSLETTER ARTICLES; All articles from members and interested persons are very welcome. If you wish to submit any articles, jokes, cartoons, please have it typed or neatly handwritten. It can be submitted by mail, computer disk or E-mail to the newsletter editor at the address listed above. Submissions must be in the hands of the editor **no later than the 14 days prior** to the meeting or it may not be included.

Regular HAM Gatherings:

Alaska QRP Club, Third Friday - 7:00 PM: Hams with QRP (low power under 5 watts) and Homebrewing interests meet for a social meeting monthly. Meet at Denny's on DeBarr & Bragaw in the back room. Hungry QRPers start showing up about 6PM. Info contact Jim Larsen, AL7FS, [JimLarsen2002 at alaska.net](mailto:JimLarsen2002@alaska.net) or 345-3190.

Tuesdays Lunch, 11:30 AM: Join the gang for lunch and an eyeball QSO at the Royal Fork, "South, on Old Seward Highway. Attendance varies from 8 to 24 each week.

Thursdays Brunch, 10:30 AM: Brunch at Lily's on Tudor Road just East of Tony Romas. A great bunch of folks attend this one.

Saturdays Breakfast, 7:30 AM: Here is a good way to get started on the weekend. Come and meet with some of the locals and have a great breakfast at Phillips Restaurant, at the corner of Arctic and International. Great Fun.

THIS MONTH'S EVENTS

1st Friday each month - AARC general meeting - 7:00 PM in the Carr-Gottstein Building, on the APU Campus. Talk in will be on 147.30+ repeater.

1st Tuesday each month: VE License Exam 6:30 PM, at the Hope Cottage offices, 540 W International. Bring photo ID, copy of license (if any) and any certificates of completion.

1st Tuesday each month: EARS general meeting - 6:30PM in the club house/shack in the basement of Denali Hall (building 31-270) on Elmendorf AFB. Talk in on 147.67-repeater.

2nd Friday each month: SCRC general meeting at 7:00 PM at Denny's on DeBarr & Bragaw. Talk in on 147.57 simplex.

2nd Saturday each month: VE License Exams at 2:00 PM. at Hope Cottage 540 W. International. Be sure to bring photo ID, copy of license (if any) and any certificates of completion.

2nd Saturday each month: PARKA Meeting at 11:00 AM. at Peggy's, across from Merrill Field.

3rd Tuesday each month: AARC Board meeting at 7:00 PM at Hope Cottage 540 W. International. All are invited and encouraged to attend.

3rd Friday each month: Alaska QRP Club. 7:00PM at Denny's on DeBarr in the back room. Info: Jim Larsen, 345-3190. Bring projects to share with the group. Some show up at 6:00PM to eat.

3rd Saturday each month: ARES General meeting 9:30AM to 12:00 PM. Call TJ Sheffield – KL7TS: kl7ts@arrl.net HM: 248-3864 for additional information. Also check for ARES Info at: <http://www.qsl.net/aresalaska/>

The last Friday each month: MARA meeting at 7PM Fire Station 61, located two blocks up Lucille Drive, from the Parks hwy. Talk-in help for the meeting can be acquired on either the 146.640 or 146.850 repeaters. Further details can be found by contacting Len Betts, KL7LB, [lclbak at yahoo.com](mailto:lclbak@yahoo.com) .

The last Saturday each month at 11:00 AM: Quarter Century Wireless Assoc - QCWA at the Royal Fork, South of Dimond on Old Seward Highway. You need not be a QCWA member to attend.

Who Do I Contact to Join AARC Or pay membership renewals?

Fred Erickson KL7FE
12531 Alpine Dr
Anchorage, AK 99516-3121
frederickson (at) iname.com
Phone number: 345-2181

Annual Dues are \$12 (prorated as appropriate)
Additional Member in same household is \$6
Full Time Student is no charge
Ask about Life Memberships

A Trail Journal

by: Jesse L. Jones



Journal

Friday, March 4th: <edited for length>

I arrived at Iditarod Headquarters (HQ) at eight o'clock in the morning. After checking in with the Communications Office (comms) and Logistics I am told that my nine o'clock flight has been delayed due to fog. While waiting in the comms room a radio check comes in for Rainy Pass. We soon discover radio trouble. Due to antenna placement they are able to get a signal into Anchorage but we can't get one to them. The next several hours are frantic. The situation is mostly resolved by noon when logistics tells me that my plane has arrived.

I arrive at the Yentna Roadhouse around one o'clock. Now it's time to meet the family and get my gear situated. As the day wore on, and turned into evening, everyone just seemed to relax. Working together all of the chores got done without much effort. This included cooking for thirty people and dumping the "Honey Bucket". No, both of these were not done by the same person!

Dinner conversation quickly turns to Iditarods of the past and the approaching race day. It is obvious that the people of the Yentna Check Point work hard each year because of their love of the race.

Saturday, March 5th:

My comms handbook states that a weather observation must be made at daybreak at all check points that do not have an FAA Weather Monitoring Station. Yentna is one of those check points. The report was finished by seven thirty but nobody could be reached at HQ until after eight thirty. Our post-dinner discussion from the night before gave me some ideas for a way to lighten things up. Humor, I am told, is a great way to ease tension and lighten the mood at the check point. So why not get HQ involved in the fun and entertainment too? **My morning weather report** read as follows: "Sky Conditions- Broken Daylight. Temp- Freezin' Cold. Snow Conditions- The snow is butt deep on a tall giraffe." After a long silence came questions about wind speed and temperature. We realized my humor may not be welcome back in Anchorage.

It wasn't much later that I figured out why it took so long to reach Anchorage for the weather report. A weak signal created the same problem for me in Yentna that we had the day before

with Rainy Pass. Now the hard part is fixing the problem once we know it exists. In my mind, this is also the most fun and the reason I am out here.

A Hot Stick is erected and the J-Pole antennas are moved from the dining room window to the top and middle sections of the Hot Stick. Problem not solved. Switching coax cable from the base radio to my handheld radio told me that the problem was not the antenna, their placement or the coax. Now the problem lies within the radio. Connecting a meter to the battery powering the radio reveals voltage around eleven volts. This is not enough to power a radio properly. The battery is disconnected from the radio and is replaced with a twenty-five amp power supply I brought as a back-up. The radio is now full-quieting into HQ on the medium power setting. I have just enough time to clear my tools and equipment from the dining room table in time for lunch.

This afternoon is full of adventure. The gear is set up and fully operational with several redundancies should one system fail. The race doesn't start for another twenty-six hours and we won't see the first team for thirty hours. Now it's play time! A three mile hike into the woods with a couple of the other volunteers shows you just how remote you are. A small moose is spotted in the distance but deep snow and the trail going the opposite direction makes a closer look impossible. My two elder companions decide it's time to go back to the lodge. Next, I borrow a snow machine from the Gabryszak family (who own the lodge) and set out onto the Yentna River. The ride is fun but a lot more like a jet ski than I had imagined. Being tired from the hike I limited my riding time to about fifteen minutes. Other afternoon activities included:

- ~ Snowball fight with the kids.
- ~ "Vet Judy" and I taught each other new card games.
- ~ Looking for wire cutters lost during radio work.
- ~ Testing walkie-talkies with the kids.
- ~ Arrival of Comms Partner Mike Holland sometime around five o'clock.
- ~ **Weather update to HQ:** "Be advised, Yentna Station is expecting increased darkness by nightfall." The reply came, "Yentna Station be advised, HQ is predicting increasing daylight by morning." Finally, humor at HQ!

Sunday, March 6th:

The morning weather report is issued at around seven thirty. **Today's report reads,** "Currently the wind is coming in through the window. Temp is seventy. Ceiling is, well, however high the plywood is. Snow conditions- Some snow is on the roof, but most of it is on the ground." After sending the actual weather report HQ said they liked the first report better.

Directly after breakfast Dan Gabryszak called a meeting for all volunteers at his check-point. This is our main briefing for the race this afternoon. Here, volunteers are broken into teams and then team leaders are appointed. Seeing as how there are more than sixty volunteers, such organization is essential. The teams have their own meetings and training sessions through the rest of the morning and early afternoon. The teams are expected to arrive shortly after five this afternoon.

Since the comms guys are highly trained in their field (insert laughter here) not much discussion is needed. The afternoon is occupied by testing walkie-talkies and riding snow machines. My third solo trip on a snow machine proved to be more exciting than the first. Having a more powerful

machine allowed me to reach a speed of eighty miles per hour down the main runway on the river. I was beginning to feel more comfortable so some jumps were also attempted.

We head down to the checking area on the river a little after four o'clock and have a final meeting. The Gabryzak's dog Annie is the first dog through the check point. She went from the end of the check point out the front but it was obvious she knew what was going on. The family has been hosting this event since 1982.

The first team shows up thirty-six minutes after five o'clock. From this point the next four hours are frantic periods of organized chaos sprinkled with a little teamwork. To give you an idea as to how busy this place is, we checked in seventy-nine teams in three hours and fifty-eight minutes. From what I am told this is a record for the Yentna Station.

This next section requires a little explaining... a "Couch Potato" is a kid who sits on an old couch, on the river, near a camp fire at the end of the check point. The "Couch Potato" is required to get out-times for all teams as they leave. Ok, now you will understand this next part.

After all teams are checked and times have been sent to HQ a message comes in for two of the vets. I leave on snow machine to pass the message to the vets (telling them when the planes will be picking them up the next day to move on down the trail). My next stop is the "Couch Potato" position. Pieces of paper with the out-times written on them have been lost on the trip between this point and the lodge. By me sitting there with my handheld radio I'm able to pass the information directly to Mike who then writes the time in the log and relays to HQ.

The last team doesn't leave until seven minutes after four the next morning. Those of us still awake decide to just sleep there next to the fire on the river. Straw left over from the dogs is spread on the ground and we fall asleep.

Monday, March 7th:

I'm awake shortly before seven o'clock so I go back to the lodge and get into the bathroom before anyone else is awake. **Today's weather report** reads, "Wind is calm, oh wait, Dan is breaking wind in the corner. There is a slight breeze from the southwest. Ceiling is limited by the kids and their sleeping bags duct-taped to the rafters due to limited sleeping conditions. Snow condition is spotty... spots of urine, spots of crap and doggie booties everywhere! This is Yentna Station with the morning weather reminding you, don't eat the yellow snow!" Once again, humor is hard to find at HQ.

The call comes in around ten o'clock that a plane is on it's way to get me. It's a mad dash to get the gear torn down and packed away. As luck would have it, the plane is there before I am ready. The equipment is taken and loaded into the plane while I say my good-byes up at the lodge. Email addresses are exchanged and promises are made for the next Iditarod.

Sunday, March 13th:

After three days of delayed flights we are finally booked on a commercial flight to Nome. Arriving at HQ shortly before three o'clock we begin the process of checking and weighing gear. Making sure all packages are under the fifty pound weight limit proves to be a challenge. At this point we meet our fellow volunteers who will be joining us in the Nome area. In the mix are some interesting characters. This trip will in no

way be boring! Some examples:

~ Xena. Nome Logistics. We find her wearing a Viking hat, a t-shirt supporting musher Phil "Captain" Morgan, and on top of the t-shirt is a bra decorated with markers and safety pins.
~ Sharon. White Mountain Comms. Wearing a white hat decorated with silk flowers, ribbons and bunny ears (along with three other White Mountain volunteers who claim the hats have something to do with a theme at their check point). She is surprisingly willing to set me up with her two eldest granddaughters.

We all arrive in Nome shortly after ten o'clock. All of the comms gear arrives at the airport except one package. The antennas are missing! Alaska Airlines says that there wasn't enough room on the flight so they will be coming in the morning. They are still sitting in Anchorage!

Monday, March 14th:

The ladies of White Mountain are much too eager to give me an eight o'clock wake-up call. Then, after the singing, yelling and poking, I am asked to roll over and go back to sleep so they can get dressed! Why did they even wake me up??

While drinking my morning tea and reading yesterday's newspaper, I hear a ham on the radio report that we are under a Winter Storm Warning. It isn't long before the flight to White Mountain is delayed and eventually cancelled. Planes which are scheduled to deliver food and gear to the check points are also grounded.

Snow machines show up at around two o'clock. Due to the amount of gear, food and people, they decide to make two trips. The gear, food and I will go to Safety at this time. Ray and his personal gear, along with the remaining checkpoint gear, will be leaving later this evening. I am not thrilled about this idea because it means I will, once again, set up all of the comms gear alone. The best part is that I won't only be alone, I'll be fighting 20+ mile per hour wind, snow and freezing rain as well as a wind chill in the single digits.

Tuesday, March 15th:

An early morning today revealed much the same weather as the day before. This isn't very encouraging considering White Mountain still has no volunteers or supplies. Weather observations are made around six-thirty and the report is made at seven o'clock. The report read as follows:

"Weather Observation. Safety. Sky is overcast, low ceiling. Visibility is one-quarter of a mile, obstructions include blowing snow from the southeast. The wind is a little better than yesterday, twelve miles per hour gusting to twenty. That's good enough for the girls I go with. And much like the cold shoulder I get from the girls I go with, the temperature is thirty-two degrees." HQ responded with, "Sounds like you need a little warming up in more ways than one!" I'm sure they received warning from Anchorage before I got here. They seem to be better prepared for my humor.

Ray and I play a friendly game or two of **Cribbage**. Somehow, this gets mentioned to HQ and before long it is a full blown best-of-ten tournament. Seeing as how I just learned to play at Yentna a little more than a week ago...I don't stand much of a chance but I play along anyway.

The vet for our checkpoint arrives today. He was scheduled to go to White Mountain but since the first teams were already

there the decision was made to keep him at Safety. His name is Mike Willard of Texas A&M but we call him "Doc". He is actually in Nome doing research on the dogs, but because of the weather delays slowing other vets, he is asked to work on the trail. He is unprepared for such an experience but is open to the challenge anyway. I think we will all have a great time! When he arrives we also get word from HQ that we will not be getting any more volunteers. **This means Ray and I must be the checkers too!** We had been expecting such an announcement all day so it didn't come as much of a surprise.

Anticipation builds as day turns into night. Word comes that Sorlie is the first team out of White Mountain. He will be here in the early hours of the morning.

Wednesday, March 16th:

The Iditarod Tours group stopped by today just in time for lunch. It could be the lack of organized meals for a few days, or it could simply be the fact that we didn't have to cook it ourselves, but their food was AMAZING! The guide informed us that a professional chef had been flown in to prepare the meals for this tour group. While I have no interest (or funds) to go on this tour in the future, a job as the guide would be quite nice!

The first musher in is Robert Sorlie from Norway, arriving a just minutes before five o'clock this morning. Robert is surprisingly relaxed at this point. His nearest competitor is almost two hours back. There is a little trouble getting his dogs to of the checkpoint but after a little assistance they are on their way.

The next several mushers are not nearly as relaxed. Frantically signing my checker form, yelling and tugging at dogs and questioning the times of their competition takes up the majority of their two-minute visits.

One exception to this rule is a young musher by the name of Jessica Hendricks. Her run during this year's race has been pretty outstanding. Each of her dogs appear to be doing very well and she is coming in a very respectable fifteenth place. While every other team that has been in today has had trouble making a hard left turn instead of going straight out, Jessica's team was another story. The only problem was a few dogs trying to take the booties off of their feet. This is, by the way, normal for almost every dog that comes in. When she sees this, she yells out, "Don't take your booties off!" Every single dog stands up and looks straight ahead almost as if standing at attention. Not a single foul word or physical contact with the team was needed! This demonstrates remarkable control over her team. Great job!

My favorite quote from the race thus far comes from veteran musher Ken Anderson. After completing his duties with the checkpoint he begins to prepare his team for departure. Guiding his lead dogs back onto the trail he says, "OK guys, let's go to Nome!" Keeping in mind this is the last 22 miles of a nearly 1,100 mile race, and after 9 days on the trail, now it's time to "go to Nome!"

Today, eighteen teams have passed through our little check point outside of Nome. Only forty-six left to go over what will probably be another five days here.

Thursday, March 17th:

Teams are expected in around three this morning so I stay up while Ray and Mike get some sleep. This time allows me to

wash up and do some writing in my journal. Washing up is an interesting experience without running water and below freezing temperatures. We have two boxes of baby wipes which I like to call "A Shower-In-A-Box." Now I think you get the idea. Washing your hair must be done outside. Time is something you don't have a lot of after the water is poured on your head. Because of the temperatures you only have seconds before it begins to freeze to your hair.

After the teams pass in the early morning hours I trade off with Ray and try to get some sleep. I awaken four hours later as breakfast is being prepared. Perfect timing!

The weather has cleared up, the clouds are breaking and the sun is shining! After a few more teams pass and lunch is over, I decided to go for a walk. The next teams aren't expected for about two hours so there is plenty of time to get out for a little while. Before I finish the first mile a young lady on a snowmachine stops and informs me that three teams are on their way and that I need to get back to Safety. At first I am reluctant because I'm up-trail from the check point and I don't see another person. Then, I realize that a young lady is offering to let me ride on her snowmachine with her. I changed my mind and graciously accepted the ride. (Later I find out that she was none other than **2005 Junior Iditarod Champion Melissa Owens.**)

Ray and I take advantage of some down time this evening to go for a walk. The sky provides some excellent photo opportunities. The sunset is awesome!

Sometime just after eleven o'clock tonight things begin to pick up. Looking out the window we spot three headlamps. Not too long after a fourth headlamp appears! In just an hour-and-a-half we have five teams come through! Unfortunately, we can't schedule what time the teams come through. After that big rush we are able to catch almost two hours of sleep before the next team is expected. Out here you have to grab your sleep whenever you can get it.

Friday, March 18th:

Arriving better than forty-five minutes earlier than expected, the next musher has to come in and wake us up. Not being prepared, we rush outside to discover the wind has picked up and it is bitterly cold!

I am able to go back to bed just after five-thirty and sleep until I hear noises and voices coming from the other room. After dressing I discover the girls have returned, this time Melissa and her little brother are traveling with their dog teams! Doc takes a look at one of Melissa's dogs who is suffering from a skin condition. They have to be back in Nome by noon so we don't have much time. The dog is put back into its harness and returned to its position on the team. We turn the teams around and off they go into the distance.

Out on the trail you meet all kinds of interesting people. Some of them are fellow volunteers. You have a quick bond with these because of your common connection. There are locals who either own the lodge you are staying in or live in the village you are in. These people are generally friendly and warm up quickly to your presence. Finally, there are the fans. **Like you, these people travel great distances and spend large amounts of money to get here and enjoy the race. The common thread that pulls us all together in this one place at this one time? It is your love of the race, but more importantly, your love of the dogs! So not matter what**

happens or where you all go after the race is over, chances are, you will all end up here next year!

The teams are beginning to spread out a little more now. Breaks of four to eight hours between the final teams isn't uncommon. This provides us time to sleep, eat, read and play games. Oh, and sleep some more!

Saturday, March 19th:

Once again today starts off with a late night keeping a lookout for approaching teams. After the last team of the night leaves I get to catch some sleep. By the time I wake up, breakfast is ready! That timing has to be one of the best things about being out here.

This morning we are able to finish our **Cribbage tournament**. Last night I was able to tie things up with four games each. Today the final game was a close one. I led almost the entire game, right up until the final hand. Ray was able to pull off a five games to four victory. The much anticipated prize from HQ was an Iditarod 2005 button with a piece of paper taped to the back. The paper says, "Iditarod Cribbage Tournament Champion."

A team comes in just before noon. After a short stop and a check of one of his dogs by Doc, it was time for him to go. This was easier said than done. Every time musher Bryan Mills would yell for his team to go, they would just lay down! I grabbed the harness of the lead dog and began to run down the trail. Slowly I just let go of the harness and they would keep running. That is, they ran until I stopped. I began to run again and they ran, I stopped and they stopped. I think his dogs voted me the new lead dog. Eventually he was able to get the team going on their own. Running with a dog team for a quarter of a mile is one thing. Running the final twenty-two miles to Nome is a no go.

Sunday, March 20th:

It is getting close to the end of the mushers now. The last team for today was gone by two-thirty this afternoon. He will show up in Nome as the Mushers Banquet is starting. There is only one team left on the trail. Anchorage musher "Captain" Morgan is this years red lantern and is expected into White Mountain around eight o'clock tonight.

A bunch of people stop in today to have a drink and visit with us. Their kids are full of questions about the trail and the mushers. We even took pictures of the kids wearing the bibs of scratched mushers.

After the guests leave we enjoy a large evening meal and begin sorting and packing gear. The mushers banquet started at four o'clock and was broadcast live on KNOM, a local radio station. Doc was taken by snowmachine back into Nome just in time for the banquet. We are able to listen in and enjoy some of the jokes and stories. Actually, it is probably better to listen in so that nobody gets mad when you fall asleep.

The knowledge that only one musher is on the trail allows us to turn in early for the best nights sleep in a week.

Monday, March 21st:

Today we wake up early and have our final meal at Safety. Once breakfast is over we finish packing our personal gear. The comms gear can't be torn down until the snowmachine comes. A breakdown in communications involving a vet, HQ and us creates a transportation problem. Ray was told he

would be riding back to town with vet Stu (who came out today for just a few hours as "Captain" Morgan came through). Apparently HQ forgot to inform Stu that he would be bringing back a passenger. HQ sent out only one snowmachine and sled for me and the gear. Because Ray is still here he gets on and I'm left with the gear. After about a half-hour we track down Nate Perkins, KL3NP, and he agrees to pick me up. Weather conditions are just terrible this morning, temperatures are in the teens and a wind gust is measured at greater than thirty miles per hour.

This afternoon an Italian filmmaker and his Alaskan guide pop in and out of the Roadhouse. They inform us that an Italian man has walked the trail from Anchorage and is trying to break a record. The filmmaker is doing a documentary on the attempt. The walker passes through about fifteen minutes before my ride arrives, stopping only long enough to eat lunch and drink some water. Soon he is on his way to Nome.

Nate arrives and helps me tear down the comms gear. This task takes less time than I had expected. On our way back to Nome we pass the walker and musher Morgan.

I return to HQ shortly before Morgan is to cross the finish line. We unload the gear from the sled and make our way down to the finish line. I have a chance to speak with him in the comms room a few minutes later. I told him, "We spent hours looking out the window at Safety, watching for you. We were so happy when you finally came into sight through the blowing snow." He replied with, "And I was so happy to see you guys too. Thanks."

Our plane is scheduled to leave at nine o'clock. We make our way to the airport around eight where I am reunited with the Ladies of White Mountain. We have some time to share stories and digital pictures before the plane is ready. They are not leaving on our flight so this will be the last time I see them. This year at least.



I look forward to sharing my Iditarod stories with you at the April 1st AARC meeting and hope to have a PowerPoint presentation ready to go by then. Jesse

Anchorage Amateur Radio Club, Inc
Post Office Box 101987
Anchorage, Alaska 99510-1987

PRSRT STD
U.S. Postage
PAID
Anchorage, AK
Permit No. 223



KL4E, Craig Bledsoe, shows us how to do LEO Satellites from home.

Elmer is His Name

By Mike Wood, KL1RO

When hams young and old,
Need to ask a question,
Where do you turn?
Let me make a suggestion.

There are hams out there,
Who seek neither glory nor fame,
They just want to help,
Elmer is their name.

Your Heathkit is smoking,
The finals fell apart,
Call Elmer for help,
To him radio is an art.

Your rig is now fixed,
The tubes all aglow,
Elmer's forgotten more radio,
Than I will ever know.

So when you are in a rut,
And don't know where to turn,
Give Elmer a call,
And be prepared to learn.

To all Elmers out there,
No matter where you live,
Thank you! Thank you! Thank you!
For the wisdom that you give.