



Technology At Work

Owner's Manual

For professional use only

Do not use this equipment before reading this manual!

690GXC Airless Sprayer



Model Numbers:

Low Rider Bare

High Rider Bare

Low Rider Complete

High Rider Complete

755-2000

755-2002

755-2001

755-2003

NOTE: This manual contains important warnings and instructions. Please read and retain for reference.

Table of Contents

Safety Precautions	2
Français	12
Español	14
General Description	4
Operation	4
Pre-Start	4
Purging and Priming	4
Operating the Spray Gun	5
Pressure Relief Procedure	5
Spraying	6
Spraying Technique	6
Practice	6
Cleanup	7
Flushing the Unit	7
Maintenance	7
General Repair and Service Notes	7
Daily Maintenance	8
Spray Gun Maintenance	8
Accessories	9
Troubleshooting	10
Airless Pump	10
Airless Gun	10
Spray Patterns	11
Parts Lists and Service Instructions	16
Main Assembly	16
Engine Assembly	17
Gear Box Assembly	18
Fluid Section Assembly	20
Siphon Assembly	21
Filter Block Assembly	22
Low Rider Frame Assembly	23
High Rider Frame Assembly	23
Warranty	24

Safety Precautions

This manual contains information that must be read and understood before using the equipment. When you come to an area that has one of the following symbols, pay particular attention and make certain to heed the safeguard.



This symbol indicates a potential hazard that may cause serious injury or loss of life. Important safety information will follow.



This symbol indicates a potential hazard to you or to the equipment. Important information that tells how to prevent damage to the equipment or how to avoid causes of minor injuries will follow.

NOTE: Notes give important information which should be given special attention.



HAZARD: Injection injury - A high pressure stream produced by this equipment can pierce the skin and underlying tissues, leading to serious injury and possible amputation. See a physician immediately.

DO NOT TREAT AN INJECTION INJURY AS A SIMPLE CUT! Injection can lead to amputation. See a physician immediately.

The maximum operating range of the pump is 3200 PSI/221BAR fluid pressure.

PREVENTION:

- NEVER aim the gun at any part of the body.
- NEVER allow any part of the body to touch the fluid stream. DO NOT allow body to touch a leak in the fluid hose.

- NEVER put your hand in front of the gun. Gloves will not provide protection against an injection injury.
- ALWAYS lock the gun trigger, shut the pump off, and release all pressure before servicing, cleaning the tip or guard, changing tip, or leaving unattended. Pressure will not be released by turning off the motor. The PRIME/SPRAY valve must be turned to PRIME to relieve the pressure. Refer to the PRESSURE RELIEF PRESSURE described in the pump manual.
- ALWAYS keep the tip guard in place while spraying. The tip guard provides some protection but is mainly a warning device.
- ALWAYS remove the spray tip before flushing or cleaning the system.
- The paint hose can develop leaks from wear, kinking and abuse. A leak can inject material into the skin. Inspect the hose before each use.
- NEVER use a spray gun without a trigger lock and trigger guard in place and in good working order.
- All accessories must be rated at or above 3200 PSI/221 BAR. This includes spray tips, guns, extensions, and hose.

NOTE TO PHYSICIAN:

Injection into the skin is a traumatic injury. It is important to treat the injury as soon as possible. DO NOT delay treatment to research toxicity. Toxicity is a concern with some coatings injected directly into the blood stream. Consultation with a plastic surgeon or reconstructive hand surgeon may be advisable.

HAZARD: EXPLOSION OR FIRE - Solvent and paint fumes can explode or ignite. Severe injury and/or property damage can occur.

PREVENTION:

- Provide extensive exhaust and fresh air introduction to keep the air within the spray area free from accumulation of flammable vapors.
- Avoid all ignition sources such as static electric sparks, open flames, pilot lights, and hot objects. Connecting or disconnecting power cords or working light switches can make sparks.
- Do not smoke in spray area.
- Fire extinguisher must be present and in good working order.
- Place paint pump in a well ventilated area. Flammable vapors are often heavier than air. Floor area must be extremely well ventilated. The paint pump contains arcing parts that emit spark and can ignite vapors.
- The equipment and objects in and around the spray area must be properly grounded to prevent static sparks.
- Use only conductive or grounded high pressure fluid hose. Gun must be grounded through hose connections.
- Power cord must be connected to a grounded circuit (electric models only).
- Always flush unit into a separate metal container, at low pump pressure, with spray tip removed. Hold gun firmly against side of container to ground container and prevent static sparks.
- Follow the material and solvent manufacturer's warnings and instructions.
- Use extreme caution when using materials with a flashpoint below 70° F (21° C). Flashpoint is the temperature that a fluid can produce enough vapors to ignite.
- Plastic can cause static sparks. Never hang plastic to enclose a spray area. Do not use plastic drop cloths when spraying flammable materials.
- Use lowest possible pressure to flush equipment.

GAS ENGINE (WHERE APPLICABLE)

Always place pump outside of structure in fresh air. Keep all solvents away from the engine exhaust. Never fill fuel tank with a running or hot engine. Hot surface can ignite spilled fuel. Always attach ground wire from pump unit to a grounded object, such as a metal water pipe. Refer to engine owner's manual for complete safety information.

HAZARD: EXPLOSION HAZARD DUE TO INCOMPATIBLE MATERIALS - Will cause severe injury or property damage.

PREVENTION:

- Do not use materials containing bleach or chlorine.
- Do not use halogenated hydrocarbon solvents such as mildewcide, methylene chloride and 1,1,1 - trichloroethane. They are not compatible with aluminum.
- Contact your coating supplier about the compatibility of material with aluminum.

HAZARD: HAZARDOUS VAPORS - Paints, solvents, insecticides, and other materials can be harmful if inhaled or come in contact with the body. Vapors can cause severe nausea, fainting, or poisoning.

PREVENTION:

- Use a respirator or mask if vapors can be inhaled. Read all instructions supplied with the mask to be sure it will provide the necessary protection.
- Wear protective eyewear.
- Wear protective clothing as required by coating manufacturer.

HAZARD: GENERAL - This product can cause severe injury or property damage.

PREVENTION:

- Read all instructions and safety precautions before operating equipment.
- Always disconnect the motor from the power supply before working on the equipment (electric models only).
- Follow all appropriate local, state, and national codes governing ventilation, fire prevention, and operation.
- The United States Government Safety Standards have been adopted under the Occupational Safety and Health Act (OSHA). These standards, particularly part 1910 of the General Standards and part 1926 of the Construction Standards, should be consulted.
- Use only manufacturer authorized parts. User assumes all risks and liabilities when using parts that do not meet the minimum specifications and safety devices of the pump manufacturer.
- Before each use, check all hoses for cuts, leaks, abrasion or bulging of cover. Check for damage or movement of couplings. Immediately replace the hose if any of these conditions exist. Never repair a paint hose. Replace it with another grounded high-pressure hose.
- All hoses, swivels, guns, and accessories must be pressure rated at or above 3200PSI/221 BAR.
- Do not spray outdoors on windy days.
- Wear clothing to keep paint off skin and hair.

Gasoline Engine Safety

⚠ WARNING

The engine exhaust from this unit contains chemicals known to the State of California to cause cancer, birth defects, or other reproductive harm.

1. Gasoline engines are designed to give safe and dependable service if operated according to instructions. Read and understand the engine manufacturer's Owner's Manual before operating the engine. Failure to do so could result in personal injury or equipment damage.
2. To prevent fire hazards and to provide adequate ventilation, keep the engine at least 1 meter (3 feet) away from buildings and other equipment during operation. Do not place flammable objects close to the engine.
3. Children and pets must be kept away from the area of operation due to a possibility of burns from hot engine components or injury from any equipment the engine may be used to operate.
4. Know how to stop the engine quickly, and understand the operation of all controls. Never permit anyone to operate the engine without proper instructions.
5. Gasoline is extremely flammable and is explosive under certain conditions.
6. Refuel in a well-ventilated area with the engine stopped. Do not smoke or allow flames or sparks in the refueling area or where gasoline is stored.
7. Do not overfill the fuel tank. After refueling, make sure the tank cap is closed properly and securely.
8. Be careful not to spill fuel when refueling. Fuel vapor or spilled fuel may ignite. If any fuel is spilled, make sure the area is dry before starting the engine.
9. Never run the engine in an enclosed or confined area. Exhaust contains poisonous carbon monoxide gas; exposure may cause loss of consciousness and may lead to death.
10. The muffler becomes very hot during operation and remains hot for a while after stopping the engine. Be careful not to touch the muffler while it is hot. To avoid severe burns or fire hazards, let the engine cool before transporting it or storing it indoors.
11. Never ship/transport unit with gasoline in the tank.

⚠ WARNING

DO NOT use this equipment to spray water or acid.

⚠ CAUTION

Do not lift by cart handle when loading or unloading.

General Description

This piston pump is a precision power tool used for spraying many types of materials. Read and follow this instruction manual carefully for proper operating instructions, maintenance, and safety information.

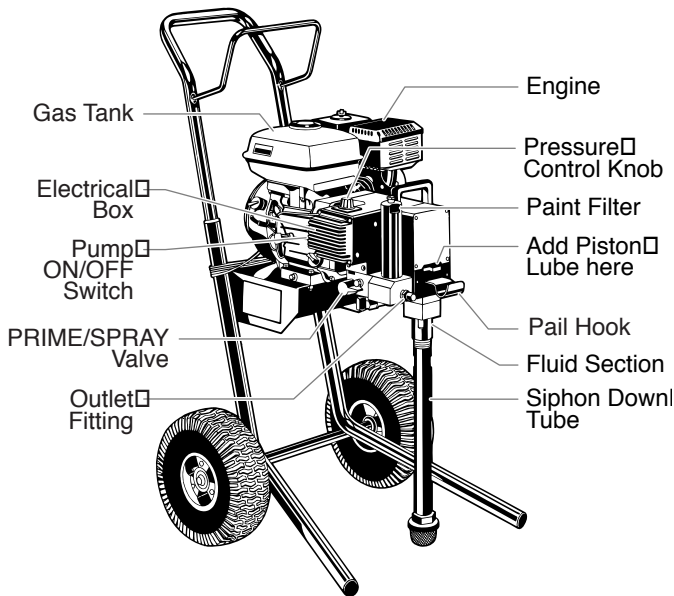

Operation

⚠ WARNING

This equipment produces a fluid stream at extremely high pressure. Read and understand the warnings in the Safety Precautions section at the front of this manual before operating this equipment.

Pre-Start

Perform the following procedure before starting the gas engine.

1. Ensure that the suction set and the return hose are attached and secure.
2. Attach a minimum of 50' of airless spray hose to the unit.
3. Attach an airless spray gun to the spray hose. Do not attach the tip to the spray gun yet. Remove the tip if it is already attached.

⚠ WARNING

Make sure all airless hoses and spray guns are electrically grounded and rated for at least 3200 psi (220 bar) fluid pressure.

4. Turn the pressure control knob fully counterclockwise to its lowest pressure setting.
5. Make sure the engine ON/OFF switch is in its OFF position.
6. Fill the wet cup with one tablespoon of Piston Lube.

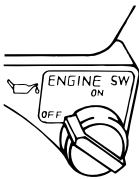

⚠ CAUTION

Never operate unit for more than ten seconds without fluid. Operating this unit without fluid will cause unnecessary wear to the packings.

7. Check the engine oil level. The gasoline engine oil level is determined by the manufacturer. Refer to the engine manufacturer's service manual (supplied).
8. Close the fuel shut-off lever and fill the gas tank with gasoline. Use only high quality, unleaded gasoline.

Purging and Priming

⚠ WARNING

Always keep the trigger lock on the spray gun in the locked position while purging the system.

If this unit is new, it is shipped with test fluid in the fluid section to prevent corrosion during shipment and storage. This fluid must be thoroughly cleaned out of the system before you begin spraying.

If it is already in service, you will need to purge the water or solvent used in cleanup.

Purging and Priming the Pump for Latex Paint

1. Secure the return hose into a waste container.
2. Place the suction tube into a container of the appropriate solvent.
3. Turn the pressure control knob fully counterclockwise its lowest pressure setting.
4. Turn the PRIME/SPRAY valve down to the PRIME position.
5. Move the pump ON/OFF switch to the ON position.
6. Move the engine ON/OFF switch to the ON position.
7. Start the engine:

- a. Open the fuel shut-off lever.
- b. Move the throttle lever away from the gas tank.
- c. Close the engine choke lever.
- d. Holding the frame with one hand, pull the starter rope rapidly and firmly. Continue to hold the rope as you let it return. Pull and return the rope until the engine starts.

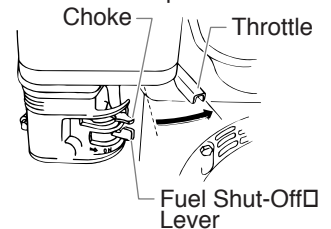

8. Slowly turn the pressure control knob clockwise to increase the pressure until fluid starts to come out of the return hose. Use only enough pressure to keep the fluid coming out.
9. Turn the pressure control knob fully counterclockwise to its lowest setting when the test fluid is purged and solvent is coming out of the return hose.
10. Remove the container of solvent from the suction tube and replace it with a bucket of clear water.
11. Increase the pressure to the minimum necessary to keep fluid flowing until clear water is coming out of the return hose.
12. Turn the pressure control knob fully counterclockwise to its lowest setting.
13. Remove the bucket of water from under the suction tube and replace it with a container of latex paint.
14. Increase the pressure slowly until paint is coming through the return hose.
15. Remove the return hose from the waste container and place it in its operating position above the container of latex paint.
16. Keep circulating the paint through the system until the paint coming out of the return hose is free of air bubbles.
17. Turn the pressure control knob fully counterclockwise to its lowest setting.

The pump is now purged. Skip to **Purging and Priming the Spray Hose.**

Purging and Priming for Solvent-Based Paint

1. Secure the return hose into a waste container.
2. Place the suction tube into a container of the appropriate solvent.
3. Turn the pressure control knob fully counterclockwise to its lowest pressure setting.
4. Turn the PRIME/SPRAY valve down to the PRIME position.

5. Move the pump ON/OFF switch to the ON position.
6. Move the engine ON/OFF switch to the ON position.
7. Start the engine:

- a. Open the fuel shut-off lever.
- b. Move the throttle lever away from the gas tank.
- c. Close the engine choke lever.
- d. Holding the frame with one hand, pull the starter rope rapidly and firmly. Continue to hold the rope as you let it return. Pull and return the rope until the engine starts.

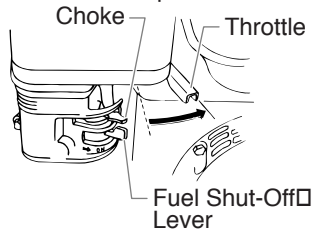

8. Slowly turn the pressure control knob clockwise to increase the pressure until fluid starts to come out of the return hose. Use only enough pressure to keep the fluid coming out.
9. Turn the pressure control knob fully counterclockwise to its lowest setting when the test fluid is purged and solvent is coming out of the return hose.
10. Remove the container of solvent from under the suction tube and replace it with a container of solvent-based paint.
11. Increase the pressure slowly until paint is coming through the return hose.
12. Remove the return hose from the waste container and place it in its operating position above the container of solvent-based paint.
13. Keep circulating the paint through the system until the paint coming out of the return hose is free of air bubbles.
14. Turn the pressure control knob fully counterclockwise to its lowest setting.

The pump is now purged. Go to **Purging and Priming the Spray Hose**.

Purging and Priming the Spray Hose

After the pump is purged and primed, you must do the same for the spray hose.

NOTE: Make sure that the spray gun does not have a tip installed.

WARNING

If a metal container is used, ground the gun by holding it against the edge of the container while flushing. Failure to do so may lead to a static electric discharge which may cause a fire.

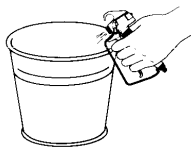

1. Turn the pressure control knob fully counterclockwise to its lowest pressure setting.
2. Turn the PRIME/SPRAY valve up to the SPRAY position.
3. Unlock the gun by turning the gun trigger lock to the unlocked position.
4. Turn the pressure control knob slowly clockwise to increase pressure.
5. Trigger the gun into a waste container until all air, water, or solvent is purged from the spray hose and paint is flowing freely.
6. Lock the gun by turning the gun trigger lock to the locked position.
7. Set down the gun and allow the unit to pressurize.
8. Check the entire system for leaks. If leaks occur, follow the **Pressure Relief Procedure** in this manual before tightening any fittings or hoses.

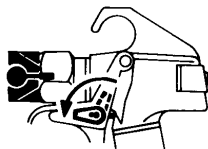

Trigger lock □ in locked position.

WARNING

Be sure to follow the “Pressure Relief Procedure” outlined in this section when shutting the unit down for any purpose, including servicing or adjusting any part of the spray system, changing or cleaning spray tips, or preparing for cleanup.

9. Unlock the gun by turning the gun trigger lock to the unlocked position.
10. Turn the pressure control knob fully counterclockwise to its lowest pressure setting.
11. Turn the PRIME/SPRAY valve down to the PRIME position and trigger the gun into the waste container to be sure that no pressure is left in the hose.
12. Lock the gun by turning the gun trigger lock to the locked position.

Operating the Spray Gun

WARNING

POSSIBLE INJECTION HAZARD. Do not spray without the tip guard in place. Never trigger the gun unless the tip is in either the spray or the unclog position. Always engage the gun trigger lock before removing, replacing or cleaning tip.

Preparing to Spray

1. Move the pump ON/OFF switch to the OFF position.
2. Make sure the gun trigger lock is in the locked position.
3. Attach tip guard and tip to the gun as instructed by the tip guard or tip manuals.
4. Move the pump ON/OFF switch to the ON position.
5. Turn the PRIME/SPRAY valve up to the SPRAY position.
6. Test the spray pattern on a piece of cardboard. Adjust the pressure control knob until the spray from the gun is completely atomized.

Pressure Relief Procedure

WARNING

Be sure to follow the “Pressure Relief Procedure” when shutting the unit down for any purpose, including servicing or adjusting any part of the spray system, changing or cleaning spray tips, or preparing for cleanup.

1. Lock the gun by turning the gun trigger lock to the locked position.
2. Move the pump ON/OFF switch to the OFF position.
3. Move the engine ON/OFF switch to the OFF position.
4. Turn the pressure control knob counterclockwise to its lowest setting.
5. Unlock the gun by turning the gun trigger lock to the unlocked position.
6. Hold the metal part of the gun firmly to the side of a metal container to ground the gun and avoid a build up of static electricity.
7. Trigger the gun to remove any pressure that may still be in the hose.
8. Lock the gun by turning the gun trigger lock to the locked position.
9. Turn the PRIME/SPRAY valve down to the PRIME position.

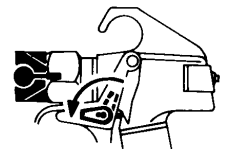

Trigger lock □ in locked position.



Spraying

⚠️ WARNING

POSSIBLE INJECTION HAZARD. Do not spray without the tip guard in place. Never trigger the gun unless the tip is in either the spray or the unclog position. Always engage the gun trigger lock before removing, replacing, or cleaning tip.

Spraying Technique

The following techniques, if followed, will assure professional painting results.

Hold the gun perpendicular to the surface and always at equal distance from the surface. Depending on the type of material, surface, or desired spray pattern, the gun should be held at a distance of 12 to 14 inches (30 to 35 cm).

Move the gun either across or up and down the surface at a steady rate. Moving the gun at a consistent speed conserves material and provides even coverage. The correct spraying speed allows a full, wet coat of paint to be applied without runs or sags.

Holding the gun closer to the surface deposits more paint on the surface and produces a narrower spray pattern. Holding the gun farther from the surface produces a thinner coat and wider spray pattern. If runs, sags, or excessive paint occur, change to a spray tip with a smaller orifice. If there is an insufficient amount of paint on the surface or you desire to spray faster, a larger orifice tip should be selected.

Maintain uniform spray stroke action. Spray alternately from left to right and right to left. Begin movement of the gun before the trigger is pulled.

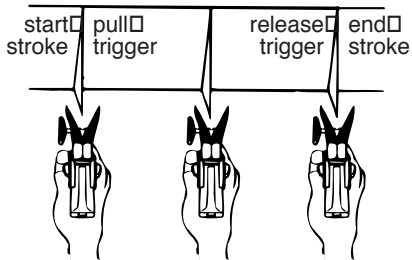

Avoid arcing or holding the gun at an angle. This will result in an uneven finish.

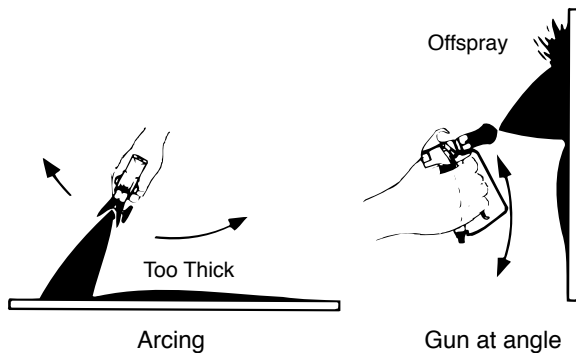

Proper lapping (overlap of spray pattern) is essential to an even finish. Lap each stroke. If you are spraying horizontally, aim at the bottom edge of the preceding stroke, so as to lap the previous pattern by 50%.

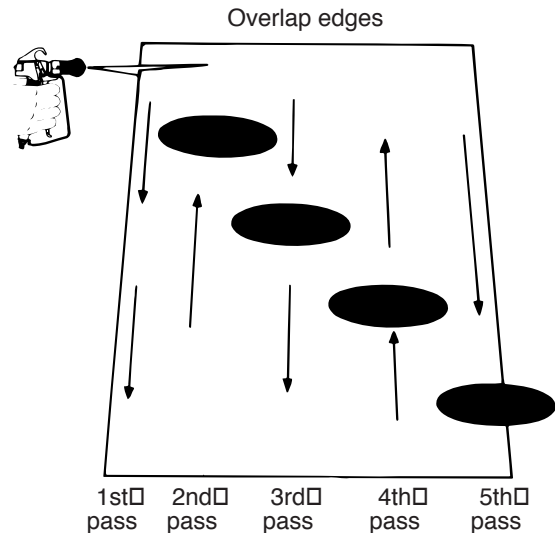

For corners and edges, split the center of the spray pattern on the corner or edge and spray vertically so that both adjoining sections receive approximately even amounts of paint.

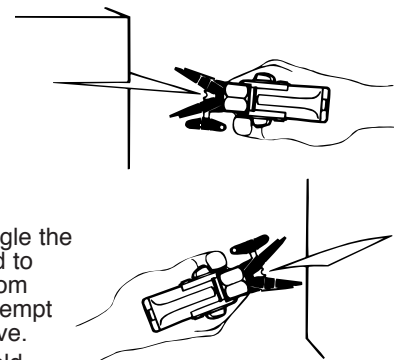

If conditions are windy, angle the spray pattern into the wind to minimize drifting. Work from ground to roof. Do not attempt to spray if wind is excessive.

When spraying with a shield, hold it firmly against the surface. Angle the spray gun slightly away from the shield and toward the surface. This will prevent paint from being forced underneath.

Shrubs next to houses should be tied back and covered with a canvas cloth. The cloth should be removed as soon as possible. Titan gun extensions are extremely helpful in these situations.

Nearby objects such as automobiles, outdoor furniture, etc. should be moved or covered whenever in the vicinity of a spray job. Be careful of any other surrounding objects that could be damaged by overspray.

Practice

1. Be sure that the paint hose is free of kinks and clear of objects with sharp cutting edges.
2. Turn the pressure control knob counterclockwise to its lowest setting.
3. Turn the PRIME/SPRAY valve up to its SPRAY position.
4. Turn the pressure control knob clockwise to its highest setting. The paint hose should stiffen as paint begins to flow through it.
5. Unlock the gun trigger lock.
6. Trigger the spray gun to bleed air out of the hose.
7. When paint reaches the spray tip, spray a test area to check the spray pattern.
8. Use the lowest pressure setting necessary to get a good spray pattern. If the pressure is set too high, the spray pattern will be too light. If the pressure is set too low, tailing will appear or the paint will spatter out in gobs rather than in a fine spray.

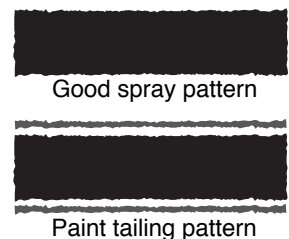

Cleanup

⚠ WARNING

Special cleanup instructions for use with flammable solvents:

- Always flush spray gun preferably outside and at least one hose length from spray pump.
- If collecting flushed solvents in a one gallon metal container, place it into an empty five gallon container, then flush solvents.
- Area must be free of flammable vapors.
- Follow all cleanup instructions.

⚠ CAUTION

The pump, hose, and gun should be cleaned thoroughly after daily use. Failure to do so permits material to cake, seriously affecting the performance of the unit.

⚠ WARNING

Always spray at minimum pressure with the gun nozzle tip removed when using mineral spirits or any other solvent to clean the pump, hose, or gun. Static electricity buildup may result in a fire or explosion in the presence of flammable vapors.

Flushing the Unit

Flush the unit with the solvent appropriate to the material being used after daily use (use solvents at room temperature). The unit should then be flushed again with mineral spirits.

For long term storage, flush the unit with an appropriate oil before storing.

1. Follow the "Pressure Relief Procedure" found in the Operation section of this manual.
2. Remove the gun tip and soak in a container filled with a solution appropriate to the type of material being sprayed.
3. Check to be sure the pressure control knob is turned fully counterclockwise to its lowest setting.
4. Prepare a container of solvent appropriate to the type of material being sprayed.
5. Move the engine ON/OFF switch to the ON position and start the engine.
6. Move the pump ON/OFF switch to the ON position.
7. Slowly turn the pressure control knob clockwise to increase the pressure until fluid starts to come out of the return hose.
8. Tilt the siphon tube above the material container and allow the unit to pump itself dry through the return hose.
9. Remove the material container and replace it with the container of appropriate solvent.
10. Allow the appropriate solvent to circulate through the unit for 2–3 minutes.
11. Turn the pressure control knob fully counterclockwise to its lowest setting.
12. Turn the PRIME/SPRAY valve up to its SPRAY position.
13. Turn the pressure control knob clockwise to increase pressure.
14. Hold the gun against the side of a metal container and trigger the gun into the container until solvent comes out and the pump, hose, and gun are clean.
15. Turn the pressure control knob fully counterclockwise to its lowest setting.
16. Turn the PRIME/SPRAY valve to PRIME. Remove the siphon tube from the solvent container.
17. Turn the pressure control knob clockwise to increase pressure and allow the unit to pump itself dry through the return tube.
18. Follow the "Pressure Relief Procedure" found in the Operation section of this manual.
19. Store in a clean, dry area.

Maintenance

⚠ WARNING

Before proceeding, follow the "Pressure Relief Procedure" in the Operation section of this manual. Additionally, follow all other warnings to reduce the risk of an injection injury, injury from moving parts or electric shock. Always unplug the sprayer before servicing!

General Repair and Service Notes

NOTE: Refer to the Parts Lists and Service Instructions section of this manual for detailed service instructions.

The following tools are needed when repairing this sprayer:

Phillips Screwdriver	3/8" Hex Wrench
Needle Nose Pliers	5/16" Hex Wrench
Adjustable Wrench	1/4" Hex Wrench
Rubber Mallet	3/16" Hex Wrench
Flat-blade Screwdriver	5/32" Hex Wrench
1/2" Open End Wrench	

1. Before repairing any part of the sprayer, read the instructions carefully, including all warnings.
2. When disconnecting wires, use needle nose pliers to separate mating connectors.

⚠ CAUTION

Never pull on a wire to disconnect it. Pulling on a wire could loosen the connector from the wire.

3. Test your repair before regular operation of the sprayer to be sure that the problem is corrected. If the sprayer does not operate properly, review the repair procedure to determine if everything was done correctly. Refer to the Troubleshooting Charts to help identify other possible problems.
4. Make certain that the service area is well ventilated in case solvents are used during cleaning. Always wear protective eyewear while servicing. Additional protective equipment may be required depending on the type of cleaning solvent. Always contact the supplier of solvents for recommendations.
5. If you have any further questions concerning your TITAN Airless Sprayer, call TITAN:

Customer Service (U.S.)	1-800-526-5362
Fax	1-800-528-4826
Customer Service (Canada)	1-800-565-8665
Fax	1-905-856-8496
Customer Service (International)	1-201-405-7520
Fax	1-201-405-7449

Daily Maintenance

Perform the following procedures daily.

Filling the Wet Cup Reservoir With Oil

Before you start to spray each day, put a tablespoon of piston seal lubricant (Piston Lube) into the wet cup in the upper pump housing.

NOTE: Do not apply so much that it overflows and drips into the paint.

It is important to maintain lubricant in the wet cup to prevent materials from adhering to the piston rod, which becomes abrasive to the upper seals. Piston Lube (see the Accessories section of this manual) will break down any material that may accumulate in the wet cup and keep it from drying.

Cleaning the Intake Screen

1. Remove the intake screen and clean with a solvent appropriate to the type of material being used.

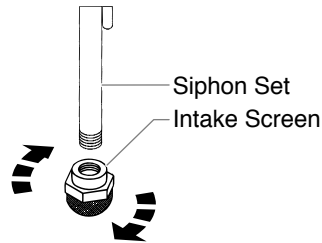

Spray Gun Maintenance

Cleaning the Spray Tip

1. Flush the gun with the appropriate solvent immediately after the work is completed.
2. Oil the retractor pins to prevent them from seizing up.

Should the spray tip become clogged, reverse the spray tip with the lever and pull the trigger. Once the obstruction comes out of the spray tip, release the trigger, reverse the spray tip back to the spray pattern setting, and resume spraying.

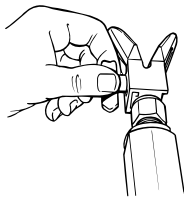

Replacing the Gun Filter

1. Move the gun trigger lock to the unlocked position.
2. Loosen and remove the handle from the gun body.
3. Turning clockwise, unscrew the filter from the gun body.

NOTE: Left-handed threads require turning the filter clockwise to remove. If the filter breaks off in the pump block, use a small wood screw to remove.

4. Turning counterclockwise, screw the new or cleaned filter into the gun body.
5. Make sure the handle seal is in position and thread the handle into the gun body until secure.
6. Move the gun trigger lock to the locked position.

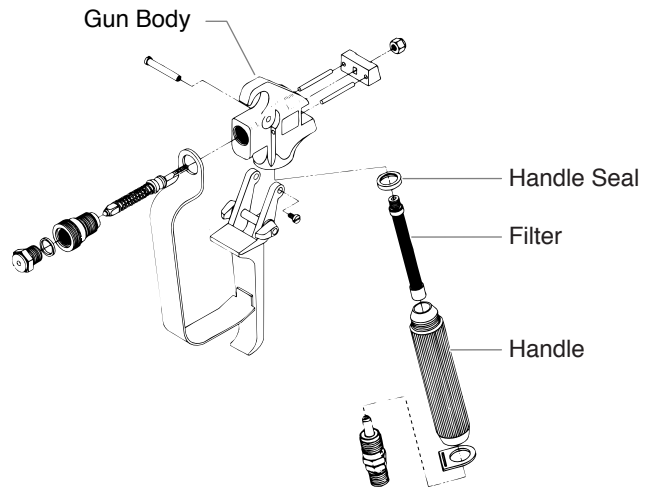

NOTE: For more detail, part number information, and assembly drawings at larger scale, please see the LX -80 Professional Airless Gun Owner's Manual (#313-012).

Accessories

Airless Tip Selection

Tips are selected by the orifice size and fan width. The proper selection is determined by the fan width required for a specific job and by the orifice size that will supply the desired amount of fluid and accomplish proper atomization.

For light viscosity fluids, smaller orifice tips generally are desired. For heavier viscosity materials, larger orifice tips are preferred. Please refer to the chart below.

NOTE: Do not exceed the pump's recommended tip size.

The following chart indicates the most common sizes and the appropriate materials to be sprayed.

Tip Size	Spray Material	Filter Type
.011 — .013	Laquers and stains	100 mesh filter
.015 — .019	Oil and latex	60 mesh filter
.021 — .023	Heavy bodied latex	30 mesh filter

Fan widths measuring 8" to 12" (20 to 30 cm) are most preferred because they offer more control while spraying and are less likely to plug.

Liquid Shield

Cleans and protects spray systems against rust, corrosion and premature wear.

Part No.	Description
700-888.....	Case of 12 (1 quart bottles)
700-889.....	1 Quart



Piston Lube

Specially formulated to prevent materials from adhering to the piston rod, which becomes abrasive to the upper seals. Piston Lube will break down any material that may accumulate in the wet cup and keep it from drying.

Part No.	Description
700-925.....	8 Ounce Individual
700-926.....	1 Quart Individual
700-911.....	Case of 12 (8 ounce bottles)
700-912.....	Case of 12 (1 quart bottles)

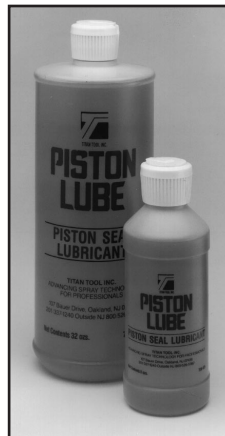

Troubleshooting

Airless Pump

Problem

Gas engine won't start

Cause

1. Engine switch not on
2. Engine oil level low
3. Out of gas
4. Spark plug cable disconnected or bad plug

Solution

1. Turn on
2. Try starting engine. If light on rear glows, add oil
3. Fill gas tank with gas
4. Connect or replace

Pump won't prime

1. Air leak in siphon hose
2. Insufficient pressure
3. Clutch worn or damaged

1. Check siphon hose o-ring and/or let paint circulate in with PRIME/SPRAY valve in the PRIME position
2. Increase pressure
3. Replace the clutch

Insufficient material flow

1. No paint
2. Inlet screen clogged
3. Pump/gun filter clogged
4. Pump will not prime, material too heavy
5. Engine not tuned properly
6. Worn clutch

1. Check supply
2. Clean
3. Clean and replace
4. Thin material
5. Tune engine
6. Service

Pump will not maintain pressure

1. Air leak in system
2. Air leak in siphon hose
3. Inlet valve not seating
4. Worn packings
5. Dirty or worn ball valves
6. Worn valve seats
7. Worn PRIME/SPRAY valve

1. Tighten connections
2. Tighten, check for leaks
3. Service or clean
4. Replace
5. Clean or replace
6. Reverse
7. Replace

Not enough pressure

1. Pressure setting too low
2. Plugged filters
3. Spray tip too big or worn
4. Engine or motor rpm too low

1. Increase
2. Clean or replace
3. Change or replace
4. Increase throttle

Excessive surge at spray gun

1. Wrong type of hose
2. Spray tip too big or worn
3. Excessive pressure

1. Replace with a minimum 50' grounded nylon braid high pressure hose
2. Change or replace
3. Decrease pressure and engine speed

Paint leaks into oil cup

1. Worn out packings

1. Replace

Airless Gun

Problem

Spitting gun

Cause

1. Air in system
2. Dirty gun
3. Needle assembly out of adjustment
4. Broken or chipped seat

Solution

1. Inspect connections for air leaks
2. Disassemble and clean
3. Inspect and adjust
4. Inspect and replace

Gun will not shut off

1. Worn or broken needle and seat
2. Needle assembly out of adjustment
3. Dirty gun

1. Replace
2. Adjust
3. Clean

Gun does not spray

1. No paint
2. Plugged filter or tip
3. Broken needle in gun

1. Check fluid supply
2. Clean
3. Replace

Troubleshooting

Spray Patterns

Problem

Tails



Cause

1. Inadequate fluid delivery

Solution

1. Fluid not atomizing correctly:
Increase fluid pressure. Change to smaller tip orifice size. Reduce fluid viscosity.
Reduce hose length. Clean gun and filter(s).
Reduce number of guns using pump.

Hour glass

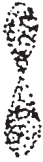

1. Inadequate fluid delivery

1. Same as above.

Distorted



1. Plugged or worn nozzle tip

1. Clean or replace nozzle tip.

Pattern expanding and contracting (surge)



1. Suction leak
2. Pulsating fluid delivery

1. Inspect for suction hose leak.
2. Change to a smaller tip orifice size. Install pulsation dampener in system or drain existing one. Reduce number of guns using pump. Remove restrictions in system; clean tip screen if filter is used.

Round pattern



1. Worn tip
2. Fluid too heavy for tip

1. Replace tip.
2. Increase pressure. Thin material. Change nozzle tip.

Sécurité

Le présent manuel comprend des renseignements devant être lus attentivement avant toute utilisation de l'appareil. Lorsque l'un des symboles suivants apparaît, il est recommandé d'être particulièrement attentif et de tenir compte des mesures de sécurité indiquées.

⚠ AVERTISSEMENT

Ce symbole indique un danger potentiel pouvant causer des blessures graves ou même mortelles. Des renseignements importants sur la sécurité sont également indiqués.

⚠ ATTENTION

Ce symbole indique un danger potentiel pouvant causer des blessures corporelles ou des dommages à l'équipement. Des renseignements importants sur la façon de prévenir tout dommage à l'équipement ou toute blessure corporelle mineure sont également indiqués.

NOTA : Les remarques donnent des renseignements importants requérant une attention particulière.

⚠ AVERTISSEMENT

DANGER: BLESSURES PAR PERFORATION - Le jet de peinture à haute pression produit par cet appareil peut perforer la peau et les tissus sous-jacents et entraîner de sévères blessures pouvant nécessiter une amputation. Consultez immédiatement un médecin.

NE PAS TRAITER UNE BLESSURE PAR PERFORATION COMME UNE SIMPLE COUPURE! Une perforation peut entraîner des risques d'amputation. Consultez immédiatement un médecin.

Pression de service maximale du fluide dans l'appareil : 3200 lb/po2 / 221BAR.

MESURES PRÉVENTIVES:

- NE JAMAIS diriger le pistolet vers une quelconque partie du corps.
- NE JAMAIS mettre une quelconque partie du corps en contact avec le jet de liquide. NE JAMAIS se mettre au contact d'un jet de liquide provenant d'une fuite du flexible d'alimentation en liquide.
- NE JAMAIS placer votre main devant le pistolet. Des gants ne vous protégeront pas contre les risques de blessures par perforation.
- TOUJOURS verrouiller la gâchette du pistolet, fermer la pompe à liquide et décompresser l'appareil lorsque vous travaillez sur celui-ci, nettoyez le protecteur de tête, remplacez la tête de pulvérisation ou vous éloignez de l'appareil. Couper le moteur ne décompresse pas l'appareil. Vous devez, pour le décompresser, placer le bouton AMORÇAGE/PULVÉRISATION en position AMORÇAGE. Reportez-vous, pour cela, à la PROCÉDURE DE DÉCOMPRESSION décrite dans de ce manuel.
- TOUJOURS s'assurer que le protecteur de tête est en place lorsque vous pulvérisiez. Le protecteur de tête offre une certaine protection contre les blessures par perforation mais sa principale fonction est d'ordre préventif.
- TOUJOURS ôter la tête de pulvérisation avant de purger ou nettoyer l'appareil.
- Le flexible d'alimentation en peinture peut fuir à la suite d'une usure, de chocs ou de mauvais traitements. Une fuite peut entraîner une perforation de la peau. Inspecter le flexible avant chaque utilisation.
- NE JAMAIS utiliser un pistolet dont la gâchette n'est pas munie d'un loquet ou un cran de sécurité qui soit en état de fonctionner.
- Tous les accessoires doivent être homologués pour une pression égale ou supérieure à 3 200 lb/po2 / 221BAR. Cela s'applique, entre autres, aux têtes de pulvérisation, aux accessoires du pistolet et aux flexibles.

AVERTISSEMENT AUX MÉDECINS : Une perforation sous-cutanée constitue un traumatisme. Il est important de traiter la blessure de façon chirurgicale aussitôt que possible. NE RETARDEZ PAS ce traitement pour des recherches de toxicité. La toxicité n'est un risque que dans les cas où certains produits de revêtement pénètrent dans le flux sanguin. Il peut être nécessaire de faire appel à des soins de chirurgie plastique ou de reconstruction de la main.

DANGER: RISQUES D'EXPLOSION OU D'INCENDIE - Les vapeurs dégagées par le solvant ou la peinture sont explosives et inflammables et peuvent causer des corporels sérieux ou dommages matériels.

MESURES PRÉVENTIVES:

- Veiller à éviter toute accumulation de vapeurs inflammables en vous assurant que la zone où la pulvérisation a lieu est suffisamment ventilée.
- Veiller à éviter la présence de toute source incandescente telle qu'étincelle électrostatique, flamme nue, flamme-pilote, objet brûlant, cigarette et étincelle provenant du branchement ou du débranchement d'un cordon d'alimentation électrique ou d'un commutateur.
- Ne pas fumer dans la zone d'épandage.
- Toujours avoir un extincteur en état de fonctionner à portée de la main.
- Placer la pompe à peinture à une distance d'au moins un mètre (3 pi) (on recommande d'ailleurs une plus grande distance) de l'objet qui doit être vaporisé dans une pièce séparée bien aérée, ou à une distance d'au moins six mètres (20 pi) de celui-ci dans une zone bien aérée (utiliser d'autres tuyaux si nécessaires). Les vapeurs inflammables sont souvent plus lourdes que l'air. Le plancher doit être extrêmement bien aéré. La pompe à peinture contient des pièces pouvant créer des étincelles et enflammer les vapeurs présentes dans l'air.
- Le matériel utilisé, ainsi que les objets se trouvant à proximité de la zone de pulvérisation, doivent être convenablement reliés à la terre afin d'éviter toute étincelle ou toute décharge électrostatique.
- N'utiliser que des flexibles d'alimentation en liquide à haute pression conducteurs ou reliés à la terre dans les cas d'utilisation sans air comprimé. S'assurer que le pistolet est convenablement relié à la terre par l'intermédiaire du flexible.
- Le cordon d'alimentation doit être raccordé à un circuit mis à la terre (les modèles électriques seulement).
- Toujours purger l'appareil dans un contenant métallique séparé, en s'assurant que la pompe soit à basse pression et que le chapeau soit retiré. Tenir le pistolet fermement contre la paroi du contenant pour mettre celui-ci à la terre et empêcher l'émission d'étincelles causées par l'électricité statique.
- Se conformer aux consignes et recommandations de sécurité du fabricant du solvant ou du produit.
- S'entourer de toutes les précautions possibles lorsqu'on utilise des produits ayant un point d'éclair inférieur à 21 °C (70 °F). Le point d'éclair d'un fluide est la température à laquelle les vapeurs émanant du fluide peuvent s'enflammer au contact d'une flamme ou d'une étincelle.
- Le plastique peut être une source d'étincelles provoquées par l'électricité statique. Ne jamais utiliser une couverture en plastique pour fermer une zone d'épandage ni utiliser des toiles de protection en plastique lors de la pulvérisation de matières inflammables.
- Lorsque vous purgez l'appareil, veillez à utiliser à la pression minimale.

MOTEUR À ESSENCE (DANS LES CAS OÙ CELA S'APPLIQUE)

Toujours placer la pompe à l'extérieur de la structure à l'air frais. Garder tous les solvants loin de l'échappement du moteur. Ne jamais remplir le réservoir à carburant lorsque le moteur est en marche ou lorsqu'il est chaud ; les surfaces chaudes risquent d'enflammer le carburant déversé accidentellement. Toujours raccorder un fil de mise à la terre entre la pompe et un objet mis à la terre, tel qu'une conduite d'eau métallique. Se reporter au guide d'utilisation du moteur pour obtenir de plus amples renseignements concernant la sécurité.

DANGER: RISQUES D'EXPLOSION PAR INCOMPATIBILITÉ DES MATÉRIAUX - Peut être à l'origine de corporels sérieux ou dommages matériels.

MESURES PRÉVENTIVES:

- Ne pas utiliser de matériaux contenant des agents de blanchiment ou du chlore.
- Ne pas utiliser des solvants à base d'hydrocarbure halogéné tels que l'agent anticryptogamique, le chlorure de méthylène et le trichloro-éthane-1,1,1. Ces produits ne sont pas compatibles avec l'aluminium.
- Communiquer avec votre fournisseur de revêtement pour connaître la compatibilité du matériau avec l'aluminium.

DANGER: VAPEURS NOCIVES – la peinture, les solvants, les insecticides et autres matériaux peuvent être nocifs lorsqu'ils sont inhalés ou en contact avec le corps. Les vapeurs peuvent causer une nausée importante, des évanouissements ou un empoisonnement.

MESURES PRÉVENTIVES:

- Utiliser un respirateur ou un masque chaque fois qu'il y a des risques d'inhalation de vapeurs. Lire attentivement toutes les instructions se rapportant au masque pour vérifier que celui-ci vous assure une protection suffisante contre les vapeurs toxiques.
- Porter des lunettes de protection.
- Porter des vêtements de protection, conformément aux directives du fabricant de revêtement.

DANGER: GÉNÉRALITÉS - Peut causer des dommages matériels ou corporels sérieux.

MESURES PRÉVENTIVES:

- Avant d'utiliser tout équipement, lire attentivement toutes les instructions et les consignes de sécurité
- Toujours débrancher le moteur de l'alimentation électrique avant d'effectuer des travaux sur l'appareil (les modèles électriques seulement).
- Se conformer à la législation locale, provinciale ou fédérale pour tout ce qui concerne la ventilation, la prévention des incendies et les conditions générales d'utilisation.
- Les normes de sécurité du Gouvernement américain sont régies par le Occupational Safety and Health Act (OSHA). Il est important de consulter ces normes, en particulier la section 1910 sur les normes générales et la section 1926 sur les des normes de la construction.
- N'utiliser que les pièces autorisées par le fabricant. L'utilisateur assume tous les risques et responsabilités lorsqu'il utilise des pièces qui ne sont pas conformes aux caractéristiques techniques minimales ainsi qu'aux dispositifs de sécurité du fabricant de la pompe.
- Vérifier, avant toute utilisation, que les flexibles ne présentent pas d'entaille ou de fuite, que le couvercle ne soit pas gonflé et que les raccords ne soient pas endommagés. Si le flexible a subi l'un des dommages précités, remplacez-le immédiatement. Ne jamais réparer un flexible d'alimentation en peinture. Le remplacer par un autre flexible mis à la terre.
- Tout flexible, raccord orientable, pistolet et accessoire utilisé avec cet appareil doit pouvoir fonctionner à une pression égale ou supérieure à 3 200 lb/po2 / 221BAR.
- Ne jamais pulvériser lorsqu'il vente.
- Porter des vêtements pour protéger la peau et les cheveux contre tout contact avec la peinture.

Sécurité du moteur à essence

⚠ AVERTISSEMENT

L'État de la Californie reconnaît que les gaz d'échappement de cet appareil contiennent des produits chimiques susceptibles de causer le cancer, des malformations congénitales ou pouvant être nocifs pour le système reproducteur.

1. Les moteurs à essence sont conçus pour être fiables et sécuritaires lorsqu'ils sont utilisés selon les directives. Lire et comprendre le guide d'utilisation de moteur avant de faire fonctionner le moteur. Le non-respect de cet avertissement risque de causer des blessures graves ou d'endommager l'appareil.
2. Afin de prévenir les risques d'incendie et d'assurer une ventilation adéquate, garder le moteur à une distance d'au moins un mètre (3 pi) des bâtiments et des autres appareils durant le fonctionnement. Ne pas placer des objets inflammables près du moteur.
3. Les enfants et les animaux doivent être tenus à l'écart de la zone de fonctionnement de l'appareil afin d'éviter les risques de brûlures causées par les composants chauds du moteur ou par les équipements utilisés avec le moteur.
4. Savoir comment couper le moteur rapidement et bien comprendre le fonctionnement de toutes les commandes. Ne jamais laisser quiconque utiliser le moteur sans lui avoir d'abord fourni les directives appropriées.
5. Le carburant est une matière extrêmement inflammable et peut exploser sous certaines conditions.
6. Ravitailler en carburant dans un endroit bien aéré une fois le moteur arrêté. Ne pas fumer et s'assurer qu'il n'y ait ni flammes ni étincelles dans la zone de ravitaillement ou d'entreposage du carburant.
7. Ne pas trop remplir le réservoir d'essence. Après le ravitaillement, s'assurer que le bouchon du réservoir soit bien fermé et serré.
8. Prendre soin de ne pas renverser de carburant lors du ravitaillement, car les vapeurs émanant du carburant ou le carburant déversé accidentellement peuvent s'enflammer. En cas de déversement, s'assurer que l'endroit soit complètement sec avant de démarrer le moteur.
9. Ne jamais mettre le moteur en marche dans un endroit fermé ou restreint, car les gaz d'échappement contiennent des matières toxiques, telles que le monoxyde de carbone, susceptibles de provoquer des évanouissements ou même d'entraîner la mort.
10. Le silencieux devient très chaud durant le fonctionnement et le demeure pendant un certain temps une fois le moteur arrêté. S'assurer d'attendre quelques minutes avant de toucher au silencieux. Pour éviter les risques de brûlures graves ou d'incendie, laisser le moteur se refroidir avant de le transporter ou de l'entreposer à l'intérieur.
11. Ne jamais expédier ou transporter l'appareil lorsque le réservoir est rempli de carburant.

⚠ AVERTISSEMENT

Ne pas utiliser cet appareil pour vaporiser de l'eau ou de l'acide.

⚠ ATTENTION

Ne pas soulever par la poignée du chariot lors du chargement ou du déchargement.

Seguridad

Este manual contiene información que debe leer y comprender antes de usar el equipo. Cuando se encuentre con uno de los siguientes símbolos, asegúrese de observar sus indicaciones de seguridad.

⚠ ADVERTENCIA

Este símbolo indica la existencia de un peligro potencial que puede causar lesiones graves o la muerte. Después del mismo se incluye información de seguridad importante.

⚠ PRECAUCION

Este símbolo indica la existencia de un peligro potencial para usted o el equipo. Después del mismo se incluye información importante que indica la forma de evitar daños al equipo o la forma de prevenir lesiones menores.

NOTA: los avisos contienen información importante, présteles especial atención.

⚠ ADVERTENCIA

PELIGRO: LESIÓN POR INYECCIÓN - La corriente de pintura de alta presión que produce este equipo puede perforar la piel y tejidos subyacentes, lo que conduciría a lesiones serias y una posible amputación. Consulte de inmediato a un médico.

NO TRATE LAS LESIONES POR INYECCIÓN COMO SI FUERAN SIMPLES CORTADAS! Una inyección puede conducir a una amputación. Consulte de inmediato a un médico.

El rango de operación máximo de la unidad es 3200 PSI / 221BAR de presión de fluidos.

PARA PREVENIR:

- NO dirija NUNCA la punta de la pistola hacia alguna parte del cuerpo.
- NO permita NUNCA que alguna parte del cuerpo tenga contacto con la corriente del fluido. EVITE tener contacto con corrientes de fluido que salgan de fugas que haya en la manguera.
- NO ponga NUNCA la mano enfrente de la manguera. Los guantes no ofrecen ninguna protección contra lesiones por inyección.
- Bloquee SIEMPRE el gatillo de la pistola, apague la bomba de fluido y libere toda la presión antes de dar mantenimiento, limpiar el protector de la boquilla, cambiar la boquilla o dejar desatendido el equipo. La presión no se liberará al apagar el motor. Para liberar la presión debe girarse la perilla PRIME/SPRAY (cebar/atomizar) hasta la posición PRIME. Consulte el PROCEDIMIENTO PARA LIBERAR LA PRESIÓN que se describe en este manual.
- Mantenga puesto SIEMPRE el protector de la boquilla mientras atomice. El protector de la boquilla ofrece cierta protección contra lesiones por inyección pero es principalmente un dispositivo de advertencia.
- Quite SIEMPRE la boquilla del atomizador antes de enjuagar o limpiar el sistema.
- Pueden desarrollarse fugas en la manguera de pintura por causa del desgaste, retorcimientos o el abuso. Una fuga es capaz de inyectar el material en la piel. Cada vez que use la manguera de pintura, inspecciónela antes.
- NO use nunca una pistola de atomización que no tenga un bloqueador o un protector de gatillo puesto y que funcione.
- Todos los accesorios deben tener una capacidad de 3200 lb/pulg² / 221BAR o mayor. Esto incluye las boquillas de atomizador, pistolas, extensiones y mangueras.

NOTA PARA EL MÉDICO: La inyección dentro de la piel es una lesión traumática. Es importante que la lesión se trate quirúrgicamente tan pronto como sea posible. NO retrase el tratamiento por investigar la toxicidad. La toxicidad es motivo de preocupación con algunos revestimientos que se inyectan directamente en la corriente sanguínea. Es recomendable consultar a un cirujano plástico o reconstructor de manos.

PELIGRO: EXPLOSIÓN O INCENDIO - Los vapores de solventes y pintura pueden explotar o incendiarse, causando con esto lesiones severas y/o daños en la propiedad.

PARA PREVENIR:

- Debe proveerse un escape y aire fresco para hacer que el aire que está dentro del área de atomización se mantenga libre de acumulaciones de vapores inflamables.
- Evite todas las fuentes de ignición como son las chispas electrostáticas, llamas abiertas, flamas de piloto, objetos calientes, cigarros, y chispas que se generan al conectar y desconectar las extensiones o de apagadores de luz que estén funcionando.
- No fume en la zona de trabajo.
- Debe haber un equipo para extinguir incendios permanentemente y en buenas condiciones.
- Coloque la bomba para pintar a un mínimo de 1 m (de preferencia más) en una habitación aparte, bien ventilada, alejada del objeto que va a pintar o a por lo menos 6 m de dicho objeto, en una zona bien ventilada (utilice una manguera más larga, si es necesario). Los gases inflamables a menudo son más pesados que el aire. La zona del piso debe tener la debida ventilación. La bomba para pintar contiene piezas que forman arcos que emiten chispas y pueden encender los gases.
- El equipo que se utilice, así como los objetos que estén dentro y alrededor del área de atomización, deben conectarse a tierra de manera apropiada para prevenir las descargas eléctricas y las chispas.
- Use solamente mangueras para fluidos de alta presión, conductoras o conectadas a tierra, para aplicaciones sin aire. Asegúrese de que la pistola esté conectada a tierra de manera apropiada, mediante conexiones de manguera.
- El cable de alimentación debe enchufarse a un circuito aterrado (eléctrico modelo único).
- Siempre enjuague la unidad en un recipiente de metal por separado, con presión baja en la bomba y sin la boquilla. Sostenga la pistola firmemente contra el recipiente para ponerlo a tierra y evitar chispas estáticas.
- Siga las advertencias y avisos de seguridad del fabricante de los materiales y solventes.
- Tenga muchísimo cuidado al usar materiales cuyo punto de ignición sea inferior a 70° F (21° C). El punto de ignición es la temperatura a la cual pueden encenderse los vapores emanados por un fluido al exponerlos a llamas o chispas.
- El plástico puede causar chispas estáticas. Nunca cuelgue plástico en las ventanas ni en las puertas del área donde va a pintar. No utilice plástico para proteger el piso cuando pinte materiales inflamables.
- Cuando enjuague el equipo utilice la presión más baja posible.

MOTOR DE GAS (SEGÚN CORRESPONDA)

Coloque siempre la bomba fuera del edificio, al aire libre. Mantenga todo solvente alejado del escape del motor. Nunca llene el tanque de combustible si el motor está encendido o caliente. La superficie caliente puede encender el combustible derramado. Conecte siempre un conductor de tierra desde la unidad de la bomba a un objeto puesto a tierra, por ejemplo una tubería de agua metálica. Consulte el manual del motor para obtener información completa de seguridad.

PELIGRO: PELIGRO DE EXPLOSIÓN DEBIDO A MATERIALES INCOMPATIBLES - Podría causar lesiones severas o daños en la propiedad.

PARA PREVENIR:

- No utilice materiales que contengan blanqueador o cloro.
- No use solventes con hidrocarburos halogenados, tales como productos para eliminar el moho, cloruro de metileno y 1,1,1 - tricloroetano. Estos no son compatibles con el aluminio.
- Comuníquese con el proveedor del producto para obtener información de compatibilidad con materiales de aluminio.

PELIGRO: GASES PELIGROSOS - Las pinturas, solventes, insecticidas y otros materiales pueden ser perjudiciales si se inhalan o entran en contacto con el cuerpo. Los gases pueden causar náusea, desmayos o envenenamiento graves.

PARA PREVENIR:

- Use una mascarilla respiratoria o careta siempre que exista la posibilidad de que se puedan inhalar vapores. Lea todas las instrucciones que vengan con la careta para estar seguro de que se tendrá la protección necesaria contra la inhalación de vapores dañinos.
- Use gafas protectoras.
- Use ropa de protección, según lo requiera el fabricante del producto.

PELIGRO: GENERAL - Puede causar daños en la propiedad o lesiones severas.

PARA PREVENIR:

- Lea todas las instrucciones y advertencias de seguridad antes de hacer funcionar cualquier equipo.
- Desconecte siempre el motor del suministro eléctrico antes de dar servicio al equipo (eléctrico modelo único).
- Observe todos los códigos locales, estatales y nacionales apropiados que rigen las medidas de ventilación, prevención de incendios y operación.
- Los Estándares de Seguridad del Gobierno de los Estados Unidos se han adoptado bajo el Acta de Seguridad y Salud Ocupacionales (OSHA por sus siglas en inglés). Deben consultarse estos estándares, particularmente la parte 1910 de los Estándares Generales y la parte 1926 de los Estándares de la Construcción.
- Utilice únicamente piezas autorizadas por el fabricante. El usuario asume todos los riesgos y responsabilidades si usa piezas que no cumplen con las especificaciones mínimas y dispositivos de seguridad del fabricante de la bomba.
- Antes de usarla cada vez, revise todas las mangueras para ver que no tengan cortadas, fugas, una cubierta desgastada por abrasión o con abolladuras, así como uniones dañadas o que se hayan movido. Si existiera cualquiera de estas condiciones, reemplace la manguera inmediatamente. No repare nunca una manguera de pintura. Reemplácela con otra manguera conectada a tierra.
- Todas las mangueras, soportes giratorios, pistolas y accesorios que se usen con esta unidad deben tener una capacidad de presión de 3200 lb/pulg² / 221 BAR o mayor.
- No atomice en días con viento.
- Use ropa que evite el contacto de la pintura con la piel y el cabello.

Seguridad con los motores de gasolina

⚠ ADVERTENCIA

El escape del motor de esta unidad contiene químicos que el Estado de California ha determinado causan cáncer, defectos de nacimiento u otros daños al sistema reproductor.

1. Los motores de gasolina están diseñados para proporcionar un servicio seguro y fiable, si se utilizan de acuerdo a las instrucciones. Lea y entienda las instrucciones del Manual del Propietario de Honda antes de utilizar el motor. De lo contrario, podría causar lesiones personales o daño al equipo.
2. Para evitar peligros de incendio y para proporcionar una ventilación adecuada, mantenga el motor por lo menos a 1 metro de los edificios y de otro equipo durante su uso. No coloque objetos inflamables cerca del motor.
3. Mantenga a los niños y las mascotas alejados de la zona de trabajo, pues existe la posibilidad de quemaduras causadas por los componentes calientes del motor o lesiones causadas por cualquier equipo en el que se utilice el motor.
4. Sepa cómo apagar el motor rápidamente y comprenda el funcionamiento de todos los controles. Nunca permita a nadie operar el motor sin las instrucciones apropiadas.
5. La gasolina es extremadamente inflamable y es explosiva bajo ciertas condiciones.
6. Llene el tanque de combustible en un lugar bien ventilado y con el motor apagado. No fume ni permita que haya llamas ni chispas en la zona de llenado ni en donde se almacena el combustible.
7. No llene en exceso el tanque de combustible. Después de ponerle combustible, asegúrese de que la tapa del tanque esté cerrada completamente.
8. Tenga cuidado de no derramar el combustible. Los gases del combustible o el combustible derramado pueden encenderse. Si se derrama combustible, asegúrese de que la zona esté seca antes de encender el motor.
9. Nunca utilice el motor en un lugar encerrado o confinado. El escape contiene gas de monóxido de carbono venenoso; la exposición a este gas puede causar pérdida del conocimiento y puede conducir a la muerte.
10. El escape se calienta mucho durante su uso y permanece caliente durante un rato después de apagar el motor. Asegúrese de no tocar el escape cuando esté caliente. Para evitar quemaduras graves o peligros de incendio, deje que el motor se enfríe antes de transportarlo o guardarlo bajo techo.
11. Nunca envíe ni transporte la unidad con gasolina en el tanque.

⚠ ADVERTENCIA

No utilice este equipo para rociar agua o ácido.

⚠ PRECAUCIÓN

No cargue el equipo por el asa del carrito durante la carga y descarga.

Parts Lists and Service Instructions

Main Assembly

⚠ WARNING

When transporting a unit with a gas engine, make sure the fuel is shut off.

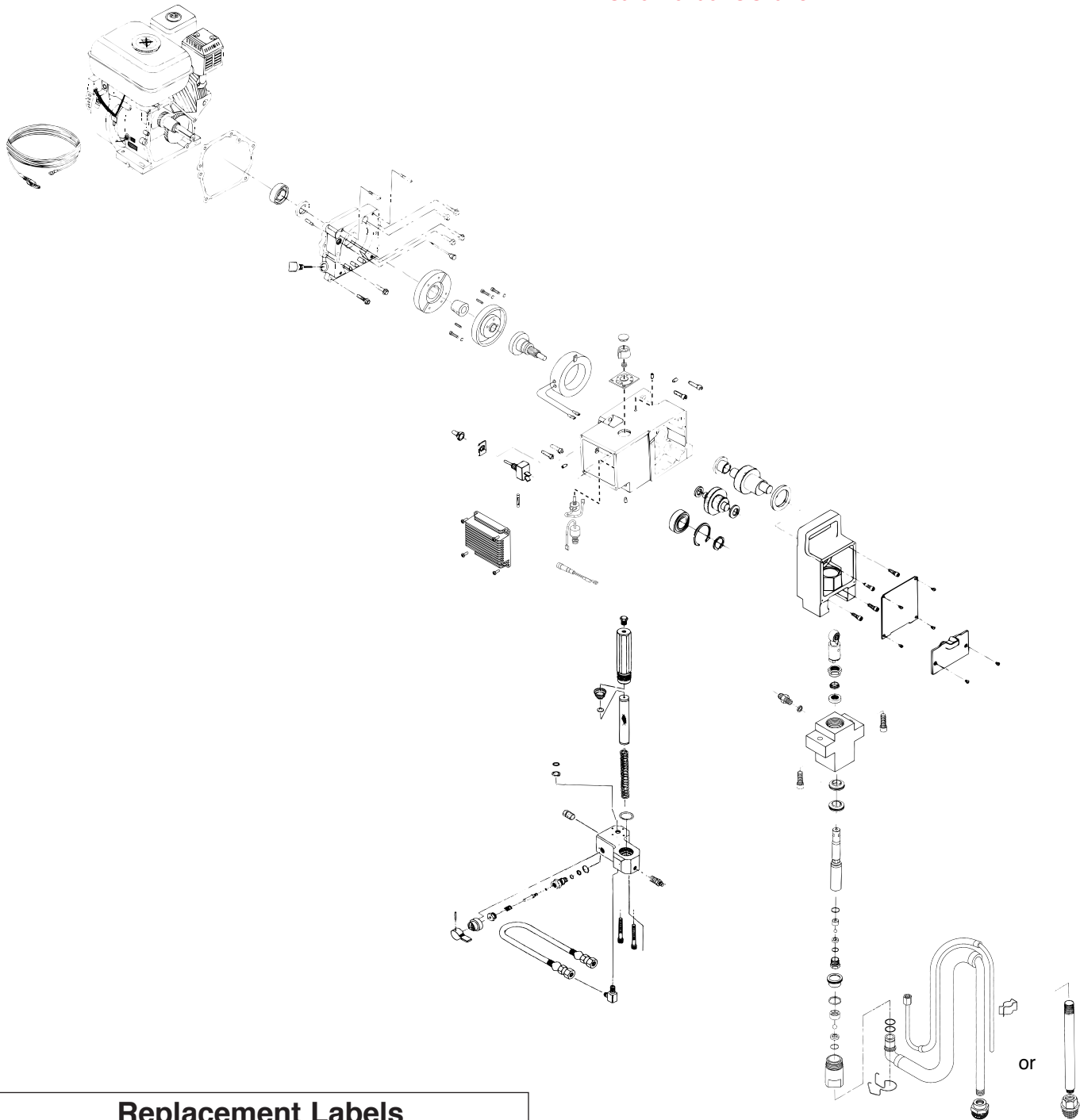

Replacement Labels

Part #	Description	Quantity
700-1018	Front cover label	1
313-1439	"690" label.....	1
313-132	"Titan" label.....	1
313-174	"Warning" label (English)	1
313-175	"Warning/Attention" label (French).....	1

NOTE: Siphon down tube for use with High Rider only.

Engine Assembly

NOTE: All service work on the Engine must be done by a Honda Authorized Service Center. To locate one in your area, call Titan Customer Service at 1-800-526-5362.

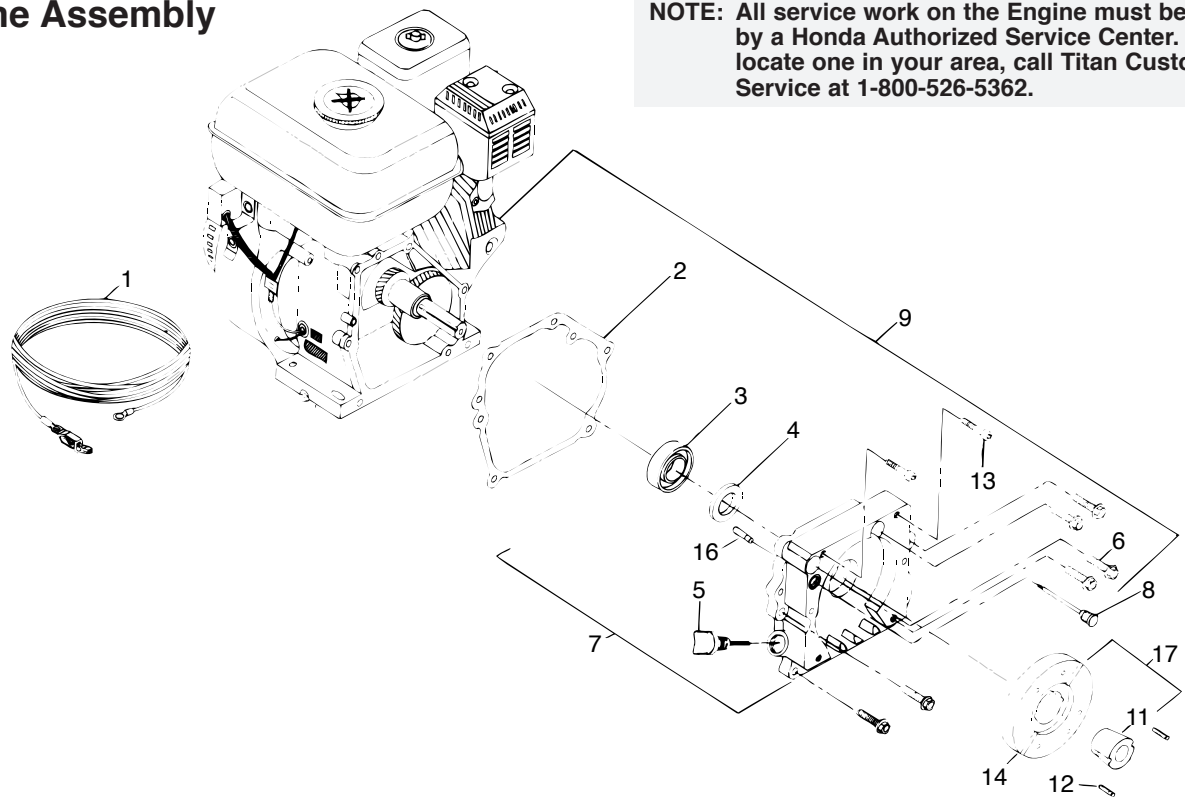

Item	Part #	Description	Quantity
1	730-165	Ground Wire.....	1
2	750-042	Gasket.....	1
3	750-044	Engine Bearing.....	1
4	750-043	Engine Seal.....	1
5	730-158	Dip Stick.....	1
6	750-051	Screw.....	6
7	750-086	Engine Mount (includes items 3 and 4)....	1
8	730-184	Electrical Connector.....	1
9	755-117	Engine Assembly.....	1
		(includes items 2-8, 13 and 16)	
11	763-550	Bushing.....	1
12	763-566	Screw.....	2
13	750-018	Screw.....	2
14	755-209	Clutch Plate.....	1
16	700-722	Terminal.....	1
17	755-150	Clutch Assembly.....	1
		(includes items 11, 12, and 14).....	1

Important Facts Concerning this Gas Unit

This unit contains a clutch that engages when the unit is pumping. The pump's pressure control device engages and disengages the clutch to control pressure. To prevent unnecessary wear to the clutch it is advisable to adjust your engine speed and pressure setting so as to limit the amount of times the clutch engages and disengages. This can be accomplished as follows:

Example:

Operating one gun with .019 tip. To reduce clutch wear reduce engine speed by adjusting the throttle to a low or medium setting and increase pressure only until heavy ends of spray pattern have been eliminated.

Example:

Operating one gun with .023 tip. Increase engine speed to a high setting and increase pressure until heavy ends of spray pattern have been eliminated.

Example:

Spraying light-bodied materials at low pressure. To reduce surging at the gun and to decrease clutch wear, reduce engine speed to idle and reduce pressure until desired spray pattern is achieved.

⚠ WARNING

Before proceeding, follow the "Pressure Relief Procedure" in the Operation section of this manual. Additionally, follow all other warnings to reduce the risk of an injection injury, injury from moving parts or electric shock.

Routine Engine Maintenance

NOTE: For detailed maintenance and specifications, refer to the separate engine manual supplied.

Daily: Check and fill the gas tank. After the first 20 hours of operation: Drain the oil and refill with clean oil. Check the engine oil level and fill as necessary.

Weekly: Remove the cover of the air filter and clean the element. Replace the element if necessary. If operating in an unusually dusty environment, check the filter daily and replace if necessary. (Replacement elements can be purchased from your local TITAN Dealer.)

After each 50 hours of operation: Change the engine oil.

Spark Plug: Use only a (NKG) BP6ES plug. Gap the plug to 0.025 - 0.030 in. (0.7 - 0.8 mm). Be sure to use a spark plug wrench when installing and removing the plug.

Servicing/Replacing the Clutch Assembly

1. Remove the four screws (item 54 in Gear Box parts list) that secure the engine assembly.
2. Inspect the clutch plate (14) for wear.
3. If worn, remove the two screws (12) and pull the clutch from the engine shaft.
4. To reinstall new clutch, slide the clutch plate (14) onto engine shaft.
5. Install the clutch gap tool (P/N 755-221) behind the clutch plate (14) and push the clutch against the tool until the tool touches the engine mount (7).
6. Tighten the screws (12) that secure the clutch plate (14).
7. Secure the engine assembly (9) to the pump using the four screws (item 54 in Gear Box parts list).

Gear Box Assembly

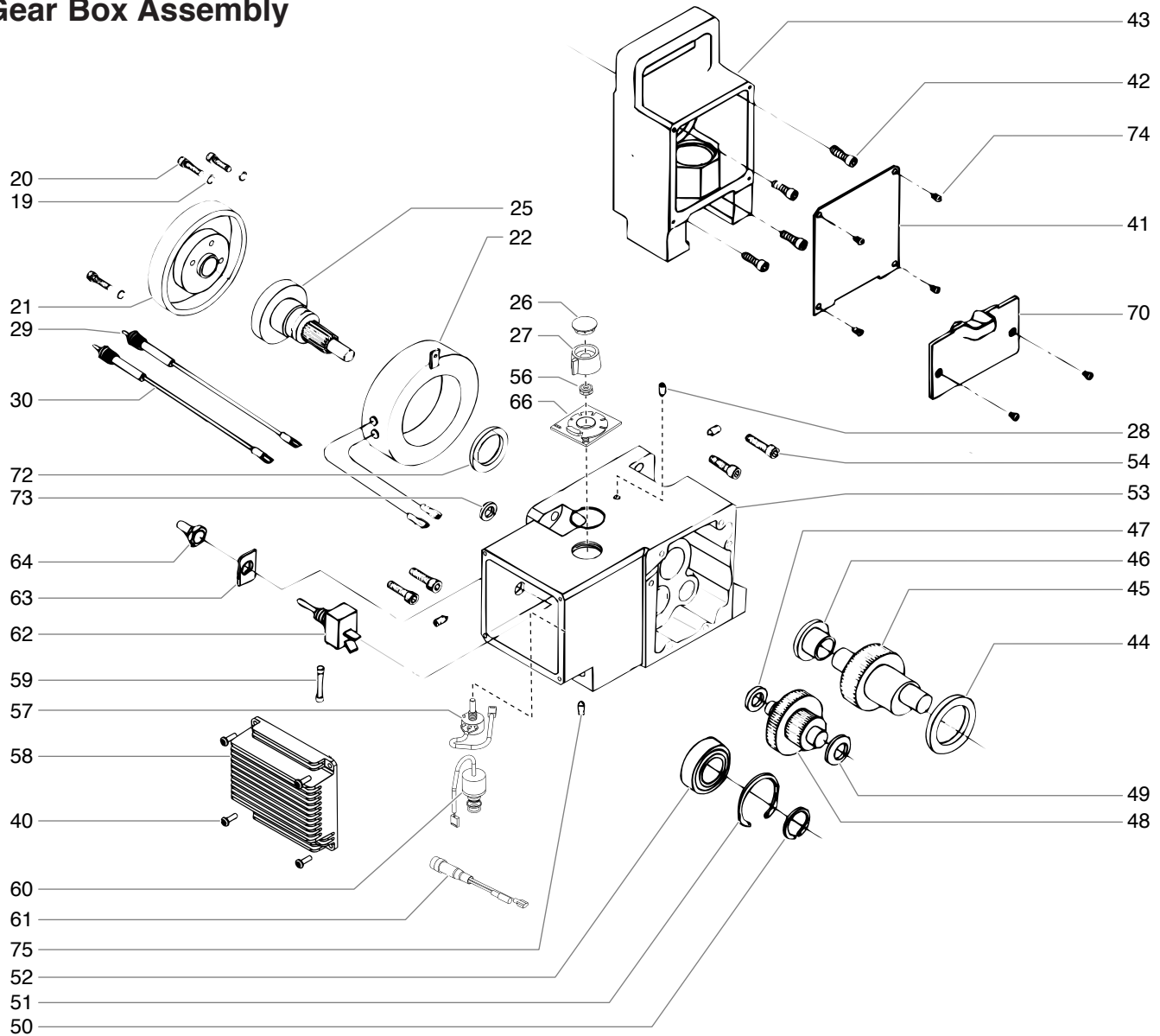

Item	Part #	Description	Quantity	Item	Part #	Description	Quantity
19	755-215	Washer	3	50	730-144	Snap ring	1
20	755-218	Screws	4	51	750-016	Snap ring	1
21	755-203	Clutch rotor	1	52	750-015	Ball bearing	1
22	755-216	Coil	1	53	755-211	Gear box housing assembly	1
25	755-201	Drive shaft and pinion	1	54	730-148	Screw	4
26	700-175	Cap	1	56	700-176	Seal tight nut	1
27	700-159	Pressure control knob	1	57	700-158	Potentiometer	1
28	763-525	Screw	4	58	700-163	Pressure control board	1
29	730-390	Connector	1	59	700-720	Fuse, 10 A	1
30	730-151	Connector	1	60	700-197	Transducer assembly	1
40	700-139	Screw	4	61	700-191	In-line fuse	1
41	700-1018	Front plate	1	62	700-646	ON/OFF switch	1
42	700-681	Screw	4	63	700-775	ON/OFF plate	1
43	750-008	Pump housing assembly	1	64	700-645	Rubber boot	1
44	700-680	Thrust washer	1	66	700-148	Potentiometer mount	1
45	730-360	Crankshaft	1	70	700-791	Safety plate	1
46	730-088	Thrust washer	1	72	730-172	Clutch seal	1
47	700-688	Thrust washer	1	73	763-561	Grommet	1
48	730-167	Output pinion gear	1	74	730-260	Screw	7
49	700-514	Thrust washer	1	75	755-224	Screw	2

WARNING

Before proceeding, follow the “Pressure Relief Procedure” in the Operation section of this manual. Additionally, follow all other warnings to reduce the risk of an injection injury, injury from moving parts or electric shock. Always unplug the sprayer before servicing!

Replacing the Clutch Rotor

1. Remove the four screws (54) that secure the engine assembly.
2. Remove the engine assembly (refer to the Engine Assembly parts list).
3. Remove the four screws (20) that secure the clutch rotor (21).
4. Remove the clutch rotor (21).
5. To install the new clutch rotor (21), reverse the above procedure.

Replacing the Pump ON/OFF Switch

1. Remove the four screws (40) that secure the pressure control board (58) to the gear box housing. Remove the pressure control board.
2. Disconnect the two black wires from the pump ON/OFF switch (62).
3. Using a wrench, remove the rubber boot (64) and the ON/OFF plate (63).
4. Remove the pump ON/OFF switch (62).
5. Install a new pump ON/OFF switch (62) and reattach the ON/OFF plate (63) and rubber boot (64). Tighten securely.
6. Reconnect the two black wires to the new pump ON/OFF switch (62).
7. Reinstall the pressure control board (58) and secure in position using the four screws (40).

Replacing/Serviceing the Gear

1. Remove safety plate (70).
2. Remove the front plate (41).
3. Remove the four socket head screws (42) that secure the pump housing (43) to the gear box housing (53).
4. Slide the pump housing (43) off the gear box housing (53).
5. Inspect the gears beginning with the crankshaft (45), followed by the output pinion gear (48).
6. Reassemble by reversing the above order. When reassembling, make sure that all washers are in place and that the gears and bearing are properly lubricated.
7. Grease the crankshaft (45) every 100 hours. The grease fitting is located under the front plate (41).
8. Grease the crank and slide connecting rod assembly every 100 hours (refer to the Fluid Section Assembly parts list). The grease fitting is located on the crank and slide connecting rod assembly under the front plate (41).

Replacing the Pressure Switch

1. Remove the old pressure switch. Be sure all loose parts are removed from the electrical box in the gear box housing (53).
2. Install the transducer assembly (60) with o-rings in place. Then, press the assembly securely into the filter block. It is recommended that you replace the polyethylene gasket that is between the pump and the filter block.
3. Reattach the filter block by guiding the transducer wires through the bottom hole of the electrical box in the gear box housing (53). Reinstall the two original bolts that mount the filter block to the pump. Be sure to tighten them evenly.
5. When installing the plastic potentiometer mount (66) from the top of the electrical box, be sure the stop (raised portion of the mount) is closest to the opening of the electrical box. Square up the mount to the opening. Use a rubber mallet to press the mount onto the pump, making it flush. Use Loctite for mounting.
6. Put the potentiometer shaft (57) through the upper hole in the electrical box, from the inside. The wires on the potentiometer should come out of the box. Turn the potentiometer clockwise or counterclockwise until it finds the locating hole and stops turning. Install the seal tight nut (56) onto the shaft of the potentiometer. Use needle nose pliers to start the nut, and with a 1/2" socket 1/4" drive, tighten to a torque of 4 in./lbs.
7. Turn the potentiometer shaft (57) clockwise until it stops.
8. Loosen the nut on the pressure control knob (27), and install onto the shaft of the potentiometer (57) with the pointer pointing away from the opening of the electrical box.
9. Hand tighten the nut onto the pressure control knob (27) and turn the knob clockwise until it hits the stop. With a 5/16" socket, tighten the nut onto the knob to 2 in./lbs. Install the plastic cap (27) onto the top of the knob.

NOTE: Do not over-tighten the nut on the potentiometer.

Electrical Schematic

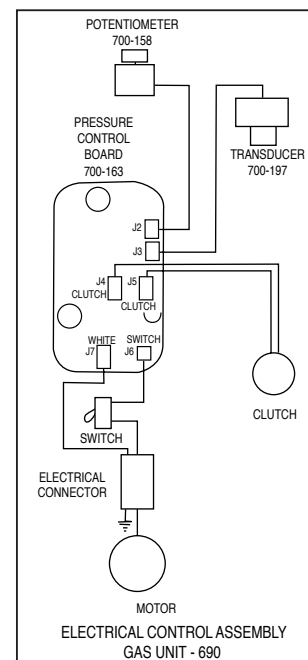

Fluid Section Assembly

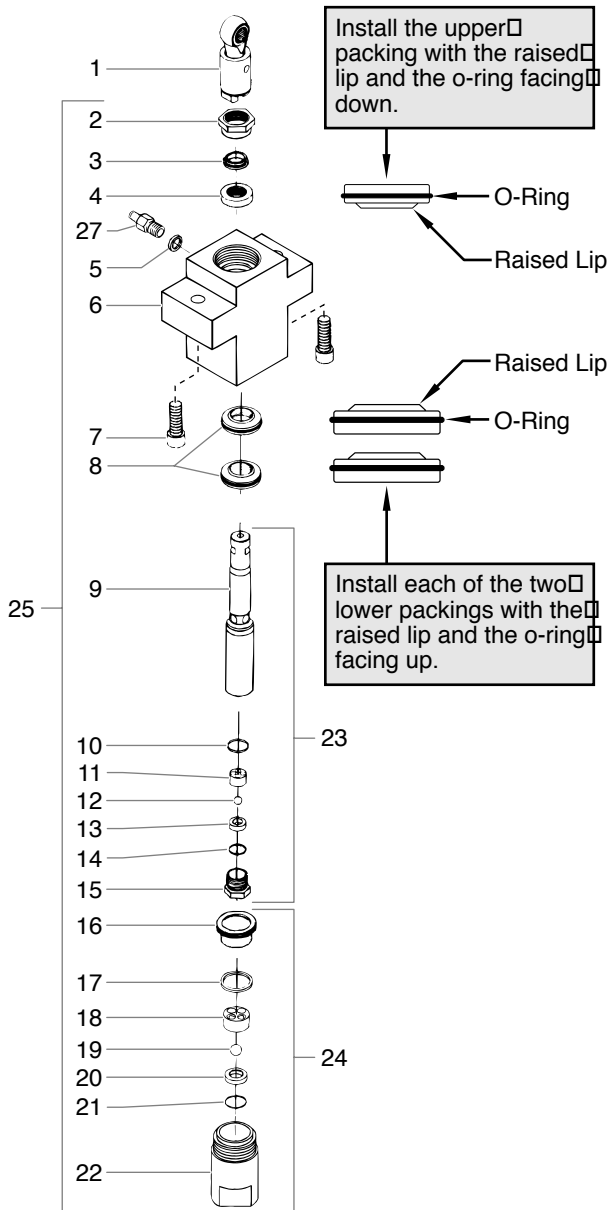

Item	Part #	Description	Quantity
1	700-735	Crank and slide connecting rod assy.	1
2	730-508	Retainer	1
3	700-587	Upper guide	1
4	700-603	Upper seal	1
5	700-804	Gasket	1
6	730-505	Pump housing	1
7	700-678	Head cap screw	2
8	700-601	Lower seal	2
9	704-089	Piston rod	1
10	762-111	Seal	1
11	762-135	Upper cage.....	1
12	762-144	Outlet valve ball.....	1
13	762-134	Seat	1
14	762-057	O-ring	1
15	762-073	Outlet valve housing.....	1
16	730-509	Bushing	1
17	700-821	Seal	1
18	730-510	Cage.....	1
19	762-145	Ball	1
20	762-137	Inlet valve seat	1
21	762-058	O-ring	1
22	704-054	Foot valve housing, low rider	1
	730-511	Foot valve housing, high rider.....	1
23	704-090	Piston assembly	1
24	730-560	Foot valve assembly, low rider	1
	730-520	Foot valve assembly, high rider.....	1
25	730-540	Fluid section complete, low rider (includes items 2-4, 6, and 8-22)	1
	765-502	Fluid section complete, high rider (excludes item 5).....	1
26	762-202	Packing tool (not shown).....	1
27	490-109	Fitting.....	1

NOTE: Repacking Kit P/N 730-401 includes items 3, 4, 5, 8, 10, 12, 14, 17, 19, 21, (packing grease P/N 700-203 and piston guide tool P/N 700-793 are also included).

Servicing/Repairing the Fluid Section

WARNING

Before proceeding, follow the "Pressure Relief Procedure" in the Operation section of this manual. Additionally, follow all other warnings to reduce the risk of an injection injury, injury from moving parts or electric shock. Always unplug the sprayer before servicing!

1. Remove the safety plate (see the "Gear Box Assembly" parts list).
2. Stop the sprayer at the top of its stroke so that the piston is in its highest position. Turn off and/or unplug the sprayer.
3. Remove the return tube with a wrench (see the "Siphon Assembly" parts list).
4. Squeeze the retaining clip together (see the "Siphon Assembly" parts list) and pull it down and out of the foot valve (22).
5. Remove the siphon assembly by pulling it down and out of the foot valve (22).
4. Tilt the pump back for easy access to the fluid section.

Servicing the Seat

The design of the fluid section allows access to the inlet and outlet valves and seat without completely disassembling the fluid section. It is possible that the valves may not seat properly because of debris stuck in the inlet or outlet seat. Follow the instructions below for access to those areas.

5. Place a wrench on the foot valve housing (22) and unthread.
6. Clean out all debris. Examine the foot valve parts and the inlet valve seat (20). If damaged replace. Continue if necessary or re-install.
7. Place a 3/4" socket on the outlet valve housing (15) and remove.
8. Clean out all debris. Examine the outlet valve parts and the seat (13). If damaged, reverse or replace.
9. Reassemble and test the unit. Should the unit not perform properly, consult the "Troubleshooting" section in this manual or continue with the valve repair and packing replacement instructions below.

Servicing/Replacing the Outlet Valve

10. To clean or replace the outlet valve, remove the outlet valve housing (15) while piston assembly (23) is still attached to pump. This will prevent the piston from rotating.
11. Remove upper cage (11), the seat (10), and the outlet valve ball (12). Clean and inspect along with the outlet valve housing (15). Replace if worn or damaged. Use fine sandpaper to remove dried paint.
12. Reattach items 10–15 to the piston rod (9), and secure tightly with a wrench.

Replacing the Packings

13. Unscrew the hose (see the "Filter Block Assembly" parts list) from the fitting.
14. Remove the screws (7) with a 3/8" hex wrench and slide the fluid section down so that the piston rod (9) is clear to slide off.
15. Inspect the polyethylene gasket (5) on the fitting after removing the fluid section. Clean or Replace.
16. Remove the retainer (2) and slide the piston rod down through the pump housing (6) by lightly tapping on top of piston assembly (23). Clean and inspect the piston rod for wear. Replace if necessary.
17. Remove the upper packings (4) and the lower packings (8) from the pump housing (6) and replace with a new set. Always insert the packings with the raised side facing into the pump housing.
18. Reattach the retainer (2) and make sure that the upper guide (3) is clean and undamaged.
19. Place the pump housing (6) into a vise, leaving enough room to slide the piston rod through the bottom of the pump housing.
20. Using the piston guide tool (included in the repacking kit), which slides over the top of the piston assembly (23), insert the piston rod through the bottom of the pump housing (6) and tap lightly with a rubber mallet on the bottom of the piston rod until inserted.
21. Align the flats on the piston rod so that they are perpendicular to the pump housing (23) and will line up when reattaching to the connecting rod (1). This can be achieved by rotating the piston rod by placing a wrench on the outlet valve housing assembly (15) and turning.



Never use a wrench on the piston rod itself. This could cause damage to the piston rod and cause leakage.

22. Slide the assembled pump housing with the piston assembly onto the connecting rod and secure with the screws (7). Be certain that the outlet hole is facing towards the pump motor.

NOTE: Packing does not need to be adjusted.

23. Reattach the hose (see the "Filter Block Assembly" parts list) to the fitting. Be sure that polyethylene gasket (5) is in place.
24. Reattach the foot valve assembly (24).
26. Reattach the return tube and the siphon assembly.

NOTE: Repacking Kit P/N 730-401 is available. For best results use all parts supplied in this kit.

Siphon Assembly (P/N 700-1025)

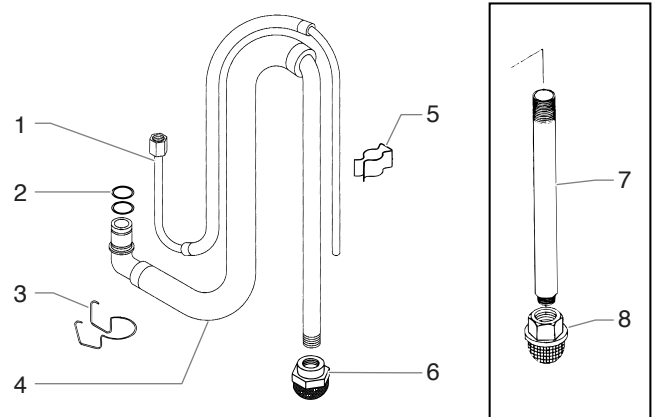

Item	Part #	Description	Quantity
1	700-847	Return tube	1
2	704-121	O-ring (standard)	2
	704-109	O-ring, solvent-resistant (optional) ..	2
3	704-127	Retaining clip	1
4	700-1023	Siphon hose (includes items 2, 3, and 6)	1
5	755-135	Clip	1
6	700-805	Intake screen	1
For high rider only:			
7	710-018	Siphon down tube	1
8	710-046	Inlet screen, 10 mesh	1
	710-191	Inlet screen, 30 mesh (optional)	1
9	761-033	Pail hook (not shown)	1
10	710-033	Bolt (for pail hook, not shown)	2
11	702-239	Return tube assembly (not shown) ..	1
12	730-334	Hose clamp (not shown)	1
13	765-142	Safety plate (not shown)	1

Filter Block Assembly

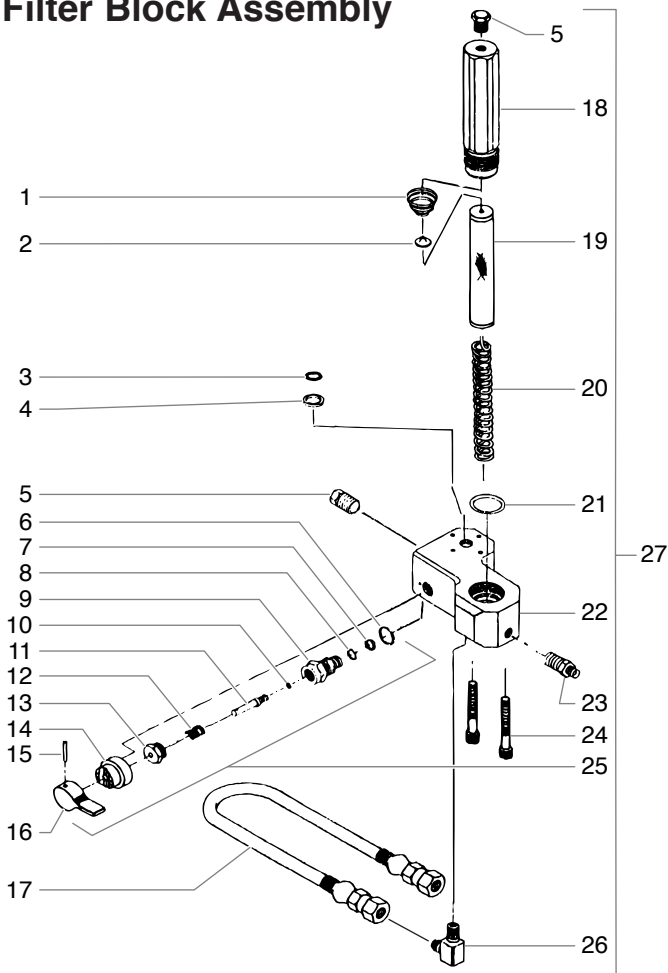

Item	Part #	Description	Quantity
1	730-083	Filter spring	1
2	702-251	Adapter	1
3	700-881	Gasket	1
4	761-057	O-ring	1
5	710-069	Plug	2
6	700-537	Gasket	1
7	221-012	O-ring	1
8	222-012	Back-up ring	1
9	700-246	PRIME/SPRAY valve housing (includes items 7 and 8)	1
10	700-721	O-ring	1
	700-897	O-ring, PTFE (optional)	
11	700-250	PRIME/SPRAY valve stem	1
12	700-244	Spring	1
13	700-248	PRIME/SPRAY valve retainer	1
14	700-252	Cam base	1
15	700-759	Dowel pin	1
16	700-697	PRIME/SPRAY valve handle	1
17	316-516	Hose	1
18	702-011	Filter housing	1
19	730-067	Filter	1
20	757-105	Filter support spring	1
21	702-303	O-ring	1
22	702-009	Filter block housing	1
23	227-006	1/4" nipple	1
24	730-262	Socket head screw	2
25	700-258	PRIME/SPRAY valve assembly	1
26	490-106	Elbow	1
27	702-305	Filter housing assembly (excludes items 3, 4, 17, and 24)	1
	700-890	O-ring tool (not shown)	1

NOTE: When using "HOT" solvents, replace o-ring item #10 with optional PTFE o-ring P/N 700-897. Install using the o-ring tool P/N 700-890.

⚠ WARNING

Before proceeding, follow the "Pressure Relief Procedure" in the Operation section of this manual. Additionally, follow all other warnings to reduce the risk of an injection injury, injury from moving parts or electric shock. Always unplug the sprayer before servicing!

Servicing/Replacing the PRIME/SPRAY Valve

1. Remove the dowel pin (15) from the PRIME/SPRAY valve handle (16). Push out the dowel pin as shown.
2. Remove the PRIME/SPRAY valve handle (16) and the cam base (14).
3. Using a wrench, loosen the PRIME/SPRAY valve housing (9) and unscrew. Inspect the o-ring (7) and the back-up ring (8).
4. Unscrew the PRIME/SPRAY valve retainer (13) and remove the PRIME/SPRAY valve stem (11).
5. Inspect the ball on the end of the PRIME/SPRAY valve stem (11) and seat, located in the PRIME/SPRAY valve housing (9). Clean or replace if damaged. Inspect the o-ring (10).
6. When reinstalling, screw completed assembly into the filter block housing (22) except for the cam base (14), dowel pin (15), and PRIME/SPRAY valve handle (16). Tighten securely with wrench. Make sure that both washers are in place.
7. Install the cam base (14) over the PRIME/SPRAY valve retainer (13), lubricate with grease. Line up the cam base with the filter block housing (22).
8. Using the dowel pin (15), line up the PRIME/SPRAY valve stem (11) with the hole on the PRIME/SPRAY valve handle (16). Secure the PRIME/SPRAY valve handle with the dowel pin.

NOTE: If the PRIME/SPRAY valve handle (227) rotates 360°, check the pin on the Cam base (225).

Replacing the Pump Filter

1. Unscrew the filter housing (18).
2. Remove the filter (19) and filter support spring (20) from the filter block housing (22).
3. Inspect the o-ring (21). Clean or replace.
4. Place the filter support spring (20) and the new or cleaned filter (19) into the filter housing (18).
5. Reattach the filter housing (18).

Low Rider Frame Assembly

Item	Part #	Description	Quantity
1	761-405	Snap Ring	2
2	761-412	Knob	2
3	755-230	Frame Legs (includes item 10)	1
4	710-058	Washer	2
5	710-044	Wheel	2
6	710-194	Snap Ring	2
7	761-410	Handle	1
8	700-652	Screws	4
9	763-549	Nut	4
10	710-199	Plug	2
11	755-400	Frame Complete	1

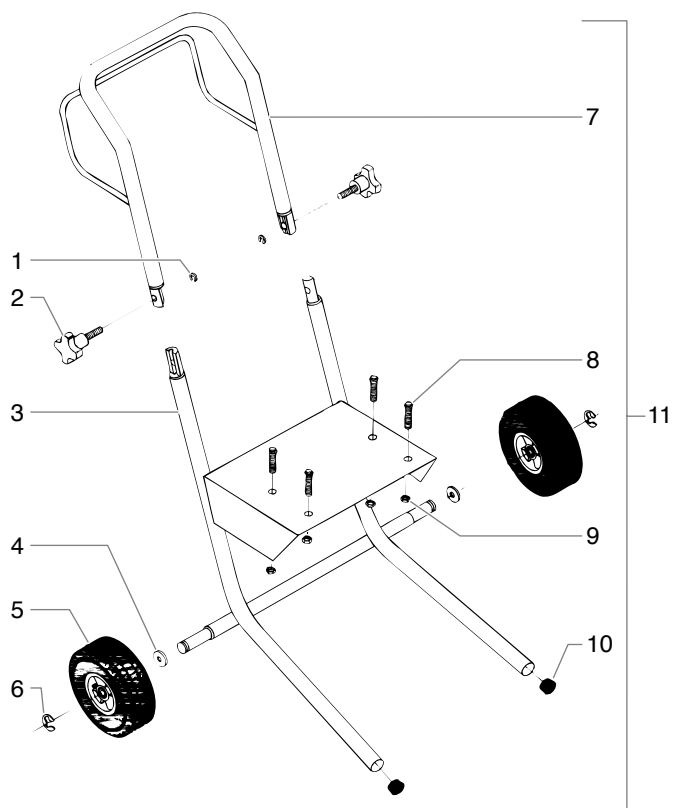

High Rider Frame Assembly

Item	Part #	Description	Quantity
1	763-543	Handle	1
2	700-784	Screw	4
4	710-058	Washer	2
5	710-044	Wheel	2
6	710-194	Snap Ring	2
3	763-555	Frame Legs (includes item 9)	1
7	700-652	Screw	4
8	763-549	Nut	4
9	710-199	Plug	2
10	763-400	Frame Complete (excludes items 7 and 8)	1

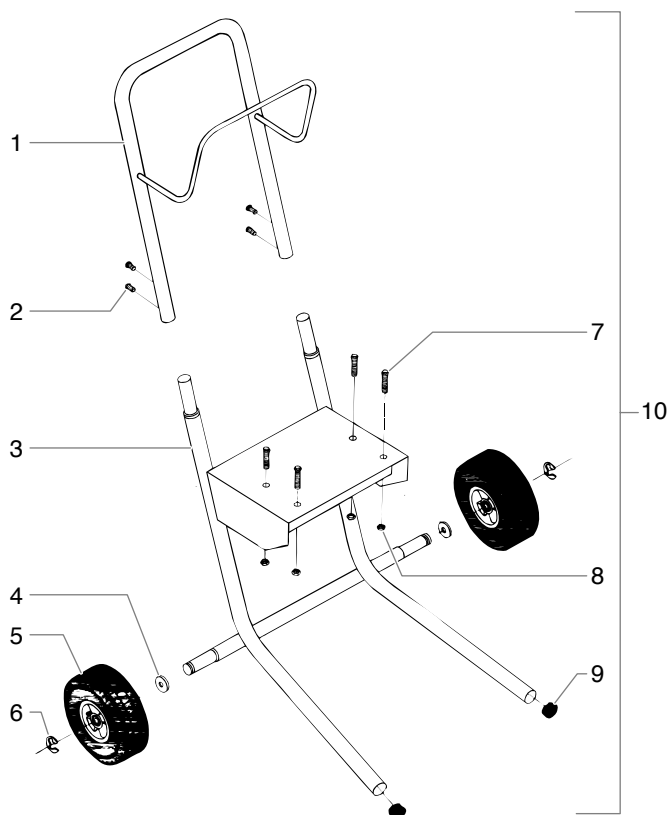

Warranty

Titan Tool, Inc., ("Titan") warrants that at the time of delivery to the original purchaser for use ("End User"), the equipment covered by this warranty is free from defects in material and workmanship. Titan's obligation under this warranty is limited to replacing or repairing without charge those parts which, to Titan's reasonable satisfaction, are shown to be defective within twelve (12) months with the exception of defects in the parts of the drive train/gear box or pressure control assembly which will be repaired or replaced for twenty four months after sale to the End User. This warranty applies only when the unit is installed and operated in accordance with the recommendations and instructions of Titan.

This warranty does not apply in the case of damage or wear caused by abrasion, corrosion or misuse, negligence, accident, faulty installation, substitution of non-Titan component parts, or tampering with the unit in a manner to impair normal operation.

Defective parts are to be returned to an authorized Titan sales/service outlet. All transportation charges, including return to the factory, if necessary, are to be borne and prepaid by the End User. Repaired or replaced equipment will be returned to the End User transportation prepaid.

THERE IS NO OTHER EXPRESS WARRANTY. TITAN HEREBY DISCLAIMS ANY AND ALL IMPLIED WARRANTIES INCLUDING, BUT NOT LIMITED TO, THOSE OF MERCHANTABILITY AND FITNESS FOR A PARTICULAR PURPOSE, TO THE EXTENT PERMITTED BY LAW. THE DURATION OF ANY IMPLIED WARRANTIES WHICH CANNOT BE DISCLAIMED IS LIMITED TO THE TIME PERIOD SPECIFIED IN THE EXPRESS WARRANTY. IN NO CASE SHALL TITAN LIABILITY EXCEED THE AMOUNT OF THE PURCHASE PRICE. LIABILITY FOR CONSEQUENTIAL, INCIDENTAL OR SPECIAL DAMAGES UNDER ANY AND ALL WARRANTIES IS EXCLUDED TO THE EXTENT PERMITTED BY LAW.

TITAN MAKES NO WARRANTY AND DISCLAIMS ALL IMPLIED WARRANTIES OF MERCHANTABILITY AND FITNESS FOR A PARTICULAR PURPOSE WITH RESPECT TO ACCESSORIES, EQUIPMENT, MATERIALS OR COMPONENTS SOLD BUT NOT MANUFACTURED BY TITAN. THOSE ITEMS SOLD, BUT NOT MANUFACTURED BY TITAN (SUCH AS GAS ENGINES, SWITCHES, HOSES, ETC.) ARE SUBJECT TO THE WARRANTY, IF ANY, OF THEIR MANUFACTURER. TITAN WILL PROVIDE THE PURCHASER WITH REASONABLE ASSISTANCE IN MAKING ANY CLAIM FOR BREACH OF THESE WARRANTIES.

Patents

These products may be covered by one or more of the following U.S. patents:

4,457,472	4,508,268	4,494,697	4,500,119	4,611,758	4,744,571	4,768,929
5,425,506	5,749,528	5,947,381				



United States Sales & Service

1-800-526-5362
Fax 1-800-528-4826

556 Commerce Street
Franklin Lakes, NJ 07417

Canadian Branch

1-800-565-8665
Fax 1-905-856-8496

200 Trowers Road, Unit 7B
Woodbridge, L4L 5Z8

International

1-201-405-7520
Fax 1-201-405-7449

556 Commerce Street
Franklin Lakes, NJ 07417 USA

www.titan-tools.com