

# BAKER 1.5 OIL PAN



- |     |           |   |
|-----|-----------|---|
| PN: | BD-1.5B   | Wrinkle Black Highlighted Pan Assembly        |
|     | BD-1.5CVO | Granite Highlighted Pan Assembly – CVO Models |
|     | BD-1.5P   | Show Polished Pan Assembly                    |
|     | BD-1.5C   | Chrome Pan Assembly                           |

## BAKER 1.5 OIL PAN OVERVIEW

### FEATURES

- Unlike oil coolers, the +1.5 pan reduces the engine oil temperature, by 16 degrees or more, whether the bike is moving down the road or stuck in traffic.
- 2-piece 6061-T6 aluminum construction with metal core gasket.
- Design features cooling fins on bottom with highlighted finish.
- Co-planar baffle labyrinth channels hot return oil from front to rear on the top plane and back to the oil pickup, in the front, on the bottom plane for complete oil circulation.
- Clearanced in the rear for crossover exhaust pipe compatibility.
- Zero leak drain plugs for engine and transmission oil.
- Easy installation and no modification required. Remove axle from rear wheel and move it rearward against the fender to remove stock pan and install new one.

### To realize maximum engine cooling benefit

Install the +1.5 pan and fill the oil sump to 5.5 quarts (+1.5 quarts) to realize the maximum reduction in oil temperature. Oil fill level on the dipstick will read the same as stock.

### To realize maximum oil blow-by reduction

Oil blow-by on SE 110 engines is a chronic issue for aggressive riders. It is caused by the larger displacement engine building up pressure in the cam chest and the oil sump. This forces oil up the push rod tubes, out the head breathers, into the air cleaner and all over the right side of the bike. Harley tech line is advising dealers to run the stock oil sump 1 quart low to increase the volume of air in the sump. This corrects the blow-by issue but makes the oil temperature skyrocket. By running the +1.5 pan at .5 quarts over stock (4.5 quarts) the blow-by condition can be cured with a small improvement in oil temperature reduction.

### FITMENT

- 2009 – Later Touring Models

### TOOLS, RESOURCES, REQUIRED PARTS

- Factory Service Manual For Your Motorcycle
- Factory Parts Manual For Your Motorcycle
- Common Hand Tools (Allen Wrenches, Sockets, Screwdrivers etc.)
- 1 7/16" Socket (Rear Wheel)
- Torque Wrench (ft-lbs. and in-lbs.)
- Blue Loctite® (242 Removable) or Equivalent
- Motor Oil; BAKER Recommends Spectro® Synthetic 20W50
- Transmission Fluid; BAKER Recommends Spectro® Synthetic GL 5, 75W140

# **BAKER 1.5 OIL PAN**

## **TABLE OF CONTENTS:**

2. Overview
3. Table Of Contents
4. Included Parts Breakdown & Legend, BAKER 1.5 Oil Pan
5. Preparation
6. Preparation / Installation
7. Installation
8. Terms
9. Disclaimer

## BAKER 1.5 OIL PAN EXPLODED VIEW

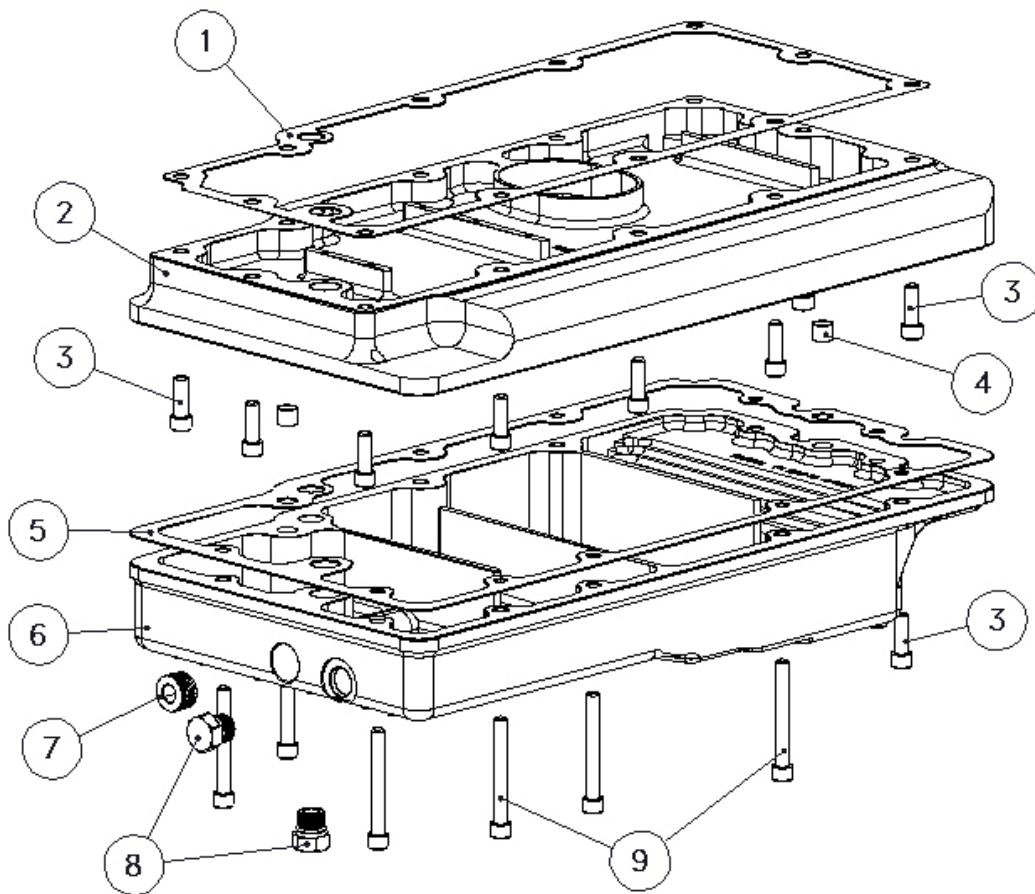

FIGURE 1

ITEM	QTY	PN	DESCRIPTION
1	1	26077-99	Gasket, Top Oil Pan
2	1	12510-09	Top Pan, Billet
3	12	25C75KCSS/P	1/4-20X3/4" SHCS Polished
4	2	609B	Alignment Dowel
5	1	12530-GAS	Gasket, Bottom Pan
6	1	12520-09	Bottom Pan, Billet
7	1	37KKPF0Z	3/8-18 NPT Socket Plug
8	2	22H-S05M-CLR	1/2-20 Zero Leak Plug, Hex
9	8	25C200KCSS/P	1/4-20X2" SHCS Polished

## BAKER 1.5 OIL PAN PREPARATION

### DISSASSEMBLY:

1. For your safety, **DISCONNECT BOTH BATTERY TERMINALS (FAILURE TO DO SO COULD RESULT IN PERSONAL INJURY)**.
2. Remove the oil and transmission drain plugs, drain fluid and dispose of at your local recycler. Remove the oil fill plug with dip stick.
3. Remove the saddle bags and place them out of the way so that they don't get damaged.
4. Remove the right side and left side exhaust muffler. Remove the left side muffler at the catalytic converter section; the crossover pipe will stay attached to the left muffler, figure 2.
5. Remove the exhaust hanger located in the rear of the oil pan.
6. Remove the rear brake caliper from the bracket by removing the 2 fastener bolts and sliding the caliper off of the brake disk and hang the caliper off of the bottom saddle bag rail so it's out of the way, figure 3.



LEFT MUFFLER WITH CROSSOVER, FIGURE 2



CALIPER REMOVAL, FIGURE 3



**DO NOT JACK ON THE CROSSMEMBER OF THE FRAME AS THIS WILL BEND. THE JACK SHOULD BE PLACED SO THAT IT CONTACTS BOTH FRAME RAILS.**

### INSTALLATION NOTE:

*Due to the design of the BAKER 1.5 Pan to maximize oil volume; the pan will not fit properly if the crossmember on the frame is bent. Make sure that the crossmember is flat and not bent upward toward the transmission. If the crossmember is bent the pan will hit on the right side frame rail. Proper fitment should leave around 1/8" clearance or more between the pan and the right side frame rail.*

7. Place a bike jack underneath the frame and raise the rear wheel, so it's just barely off of the ground; enough to get the weight of the bike off of the rear axle. Remove the rear plastic belt guard. The front bolt of the guard will stay in the swing arm, this will aid in the pan installation by holding the belt out of the way.
8. Loosen the rear axle, slide tire forward then slide the belt off of the rear pulley and remove the axle. Now slide the tire all the way back, inside the rear fender. This will allow you enough room to remove and install the BAKER 1.5 oil pan.
9. With the bike still supported, take a few 2 x 4's and block up under the motor area of the frame so you can remove the jack (get it out of the way) and the bike will stay supported properly. Make sure that you block this up under the motor so you have enough room to remove the front oil pan bolts, figure 4.



2 X 4'S UNDER THE MOTOR AREA, FIGURE 4

## BAKER 1.5 PREP / INSTALLATION

10. Using the front belt guard bolt; loosen the bolt up enough to stick the rear belt underneath it. This bolt will hold the rear belt up and out of the way while you work on the oil pan, figure 5.
11. Remove the 12 retaining bolts from the stock oil pan and remove the pan out the left rear side of the motorcycle, figure 6. Make sure not to damage the transmission to pan gasket surface area while removing the pan.
12. With the pan out of the way, use a clean lint free cloth or shop rag and wipe the gasket surface clean.



BELT UNDER BOLT, FIGURE 5



**BAKER DRIVETRAIN SHIPS THE 1.5 ASSEMBLED. THE PAN MUST BE DISSASSEMBLED FOR INSTALLATION. MAKE SURE THAT YOU DISSASSEMBLE THE PAN, USE SHOP AIR AND BLOW OUT THE INTERNAL AREA OF THE PAN TO GET RID OF ANY DEBRIS THAT MIGHT BE PRESENT FROM SHIPPING.**

**IF YOU ARE GOING TO RUN A TEMPERATURE SENSOR WITH A SENDING UNIT, REMOVE THE 3/8" NPT PLUG FROM THE FRONT OF THE BOTTOM OIL PAN AND INSTALL THE SENDING UNIT WITH PIPE THREAD SEALANT AND SNUG INTO PLACE.**



STOCK PAN REMOVAL, FIGURE 6

### BAKER 1.5 INSTALLATION:

1. Make sure and wipe down the gasket surface area of the transmission with some brake cleaner using a lint free rag. Referring to the exploded view (figure 1) get the top pan bolts (9pcs of 1/4-20x.750" SHCS) ready by applying Blue Loctite® to the threads.
2. Install the top pan with top gasket through the left rear side of the motorcycle, figure 7. Install the 9 bolts; just start the bolts for now making sure that the top gasket is aligned properly. Use two of the 1/4-20x2" SHCS bolts and just start by hand to keep the gasket aligned, refer to figure 8. Snug the 3/4" long bolts then torque to 110-130 in-lbs following the sequence in figure 8.
3. Remove the two 2" long bolts used for keeping the gasket aligned. Prepare the remainder of the BAKER 1.5 bolts by applying Blue Loctite® to the threads.

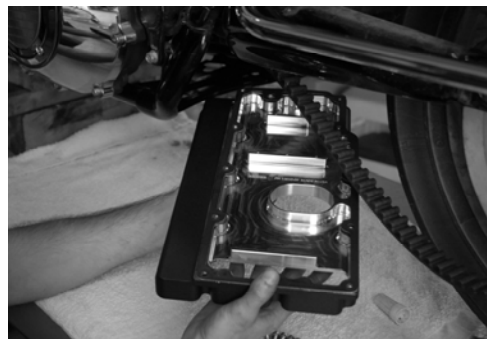

TOP PAN INSTALLATION, FIGURE 7

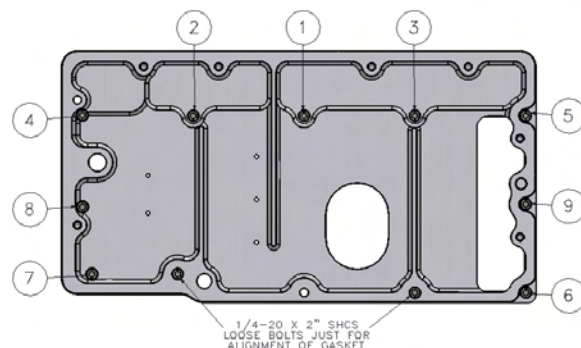

TOP PAN TORQUE SEQUENCE FIGURE 8



## BAKER 1.5 OIL PAN INSTALLATION



**BE VERY CAREFUL WHILE INSTALLING THE BOTTOM PAN WITH GASKET NOT TO DAMAGE THE GASKET DURING INSTALLATION. MAKE SURE GASKET IS ALIGNED WITH DOWEL S BEFORE PUSHING UP INTO POSITION.**

4. Install the bottom pan with gasket, figure 9.
5. After the bottom pan is in position and seated with the gasket aligned install the bottom pan bolts referring to figure 1. Snug and torque to 110-130 in-lbs referencing figure 10.
6. Following your Factory Service Manual re-install your rear wheel with belt, belt guard, exhaust hanger bracket, exhaust mufflers, and rear brake caliper.
7. Fill transmission fluid per your Factory Service Manual and fill the BAKER 1.5 with motor oil of your choice. We recommend Spectro<sup>®</sup> Synthetic V-Twin 20W50 motor oil and Spectro<sup>®</sup> Synthetic 75W140 transmission fluid.
8. When filling the motor oil, refer to page 2; depending which way best suits your needs. Test ride!

**Follow your Factory Service Manual for recommended oil change intervals.**



**BOTTOM PAN INSTALLATION, FIGURE 9**

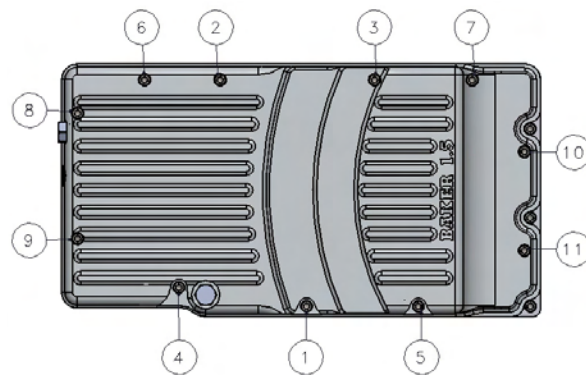

**BOTTOM PAN TORQUE SEQUENCE FIGURE 10**



**BAKER 1.5 OIL PAN INSTALLED, FIGURE 11**

# BAKER 1.5 OIL PAN TERMS

## **SPECIAL ORDERS**

A minimum \$500 deposit is required with all special orders. Special orders include unique finishes.

## **ALL OTHER ORDERS**

Orders can be pre-paid using VISA, MasterCard or American Express.

Prices shown are F.O.B. Haslett, MI. BAKER™ provides free UPS ground shipping on all retail orders for complete transmissions or transmission kit. UPS air shipment is available upon request. Customer is responsible for air shipment premiums.

## **LIMITED WARRANTY**

BAKER™ Inc. Oil Pans are guaranteed to the original purchaser to be free of manufacturing defects in materials and workmanship for a period of 5 years from the date of purchase or up to 50,000 miles - whichever is sooner.

If the product is found by BAKER™ to be defective, such products will, at the option of BAKER™, be replaced or repaired at cost to BAKER™.

In the event warranty service is required, the original purchaser must call or write BAKER™ immediately with the problem. If it is deemed necessary for BAKER™ to make an evaluation to determine whether the transmission assembly or transmission kit is defective, the entire transmission assembly, whether originally purchased as an assembly or kit, must be properly packaged and returned prepaid to BAKER™ with a copy of the original invoice of purchase.

If after an evaluation has been made by BAKER™ and a defect in materials and/or workmanship is found, BAKER™ will, at BAKER™ option, repair or replace the defective part of the assembly. Warranty card must be returned within 45 days of purchase to be valid.

## **ADDITIONAL WARRANTY PROVISIONS**

This limited warranty does not cover labor or other costs or expenses incidental to the repair and or replacement of BAKER™ products. This warranty does not apply if one or more of the following situations is judged by BAKER™ to be relevant: improper installation, accident, modification (including but not limited to use of unauthorized parts), racing, high performance application, mishandling, misapplication, neglect (including but not limited to improper maintenance), or improper repair.

BAKER™ shall not be liable for any consequential or incidental damages arising out of or in connection with a BAKER™ transmission assembly, transmission kit, component or part. Consequential damages shall include without limitation, loss of use, income or profit, or losses sustained as the result of injury (including death) to any person or loss of or damage to property.

BAKER™ transmissions, transmission kits and components are designed exclusively for use in Harley-Davidson® motorcycles. BAKER™ shall have no warranty or liability obligation if a BAKER™ part is used in any other application.

If it is determined that a BAKER™ transmission assembly has been disassembled during the warranty period for any reason, this limited warranty will no longer apply.



## **BAKER 1.5 OIL PAN DISCLAIMER**

The words Harley Davidson and H-D are registered trademarks and are for reference only. Use of H-D model designations and part numbers are for reference only. BAKER Drivetrain has no association with, and makes no claim against, these words, trademarks, or companies.

It is the sole responsibility of the user to determine the suitability of this product for his or her use, and the user shall assume all legal, personal injury risk and liability and all other as well as all other obligations, duties and risks associated therewith.

### **CUSTOMER SUPPORT**

For any installation or service questions, please contact our BAKER technical department toll free: 1-877-640-2004.

