



Operators Manual

Installation, Operation & Service

Electric T1 Skillets

**FOR MODELS
BUILT AFTER
MAY 2006:**

SEL-30-T1
SEL-40-T1



*For a complete Service Manual
refer to www.clevelandrange.com*



Enodis

1333 East 179th St., Cleveland, Ohio, U.S.A. 44110

Phone: (216) 481-4900 Fax: (216) 481-3782
Visit our web site at www.clevelandrange.com

FOR THE USER



WARNING:

Improper installation, adjustment, alteration, service or maintenance can cause property damage, injury or death.

Read the Installation and Operating instructions thoroughly before installing or servicing this equipment.

IMPORTANT

THE INSTALLATION AND CONNECTION MUST COMPLY WITH THE LOCAL AND NATIONAL ELECTRICAL CODES.

ENSURE ELECTRICAL SUPPLY CONFORMS WITH ELECTRICAL CHARACTERISTICS SHOWN ON THE RATING LABEL

ALL SERVICE MUST BE PERFORMED BY A QUALIFIED CLEVELAND RANGE TECHNICIAN.

RETAIN THIS MANUAL FOR YOUR REFERENCE.

INSTALLATION

GENERAL

Installation of the unit must be accomplished by qualified electrical installation personnel working to all applicable local and national codes. Improper installation of product could cause injury or damage.

This equipment is built to comply with applicable standards for manufacturers. Included among those approval agencies are: UL, NSF, ASME/Ntl. Bd., CSA, CGA, ETL, and others. Many local codes exist, and it is the responsibility of the owner/installer to comply with these codes.

Note: Maximum voltage for LVD (low volt directive for Europe) to be 440 volts for CE marked appliances.

INSPECTION / UNPACKING

Note: The electrical rating label is located on the right console. Serial number, voltage, phase, amperage and wattage are stated on this label.

1. Before unpacking visually inspect the unit for evidence of damage during shipping.
2. If damage is noticed, do not unpack the unit, follow "SHIPPING DAMAGE INSTRUCTIONS" shown below.
3. Carefully remove unit from shipping carton. Remove any packing material from unit. After carefully unpacking check for "concealed" damage. If damage is noticed, follow "SHIPPING DAMAGE INSTRUCTIONS" shown below.
4. Check the electrical rating label to ensure that the unit is the correct voltage, phase, amperage and wattage are stated on this label.
5. A protective material has been applied to the stainless steel panels. This material must be removed immediately after installation, as heat will melt the material and make it more difficult to remove.

SHIPPING DAMAGE INSTRUCTIONS

If shipping damage to the unit is discovered or suspected, observe the following guidelines in preparing a shipping damage claim.

1. Write down a description of the damage or the reason for suspecting damage as soon as it is discovered. This will help in filling out the claim forms later.
2. As soon as damage is discovered or suspected, notify the carrier that delivered the shipment.
3. Arrange for the carrier's representative to examine the damage.
4. Fill out all carrier claims forms and have the examining carrier sign and date each form.

CLEARANCE REQUIREMENTS

This unit must be installed in accordance with the clearances shown on the rating label which is adhered to the unit.

FOR YOUR SAFETY. Keep the appliance area free and clear of combustible materials.

INSTALLATION

Note: For clearance requirements, suggested drain location and assembly details refer to Specification Sheet.

1. Position the unit in its permanent location, and level the unit by turning the adjustable feet.

2. Once positioned and leveled, permanently secure the unit's rear flanged feet to the floor using 5/16" lag bolts and floor anchors (supplied by the installer). Three bolts are required to secure each of the flanged feet.

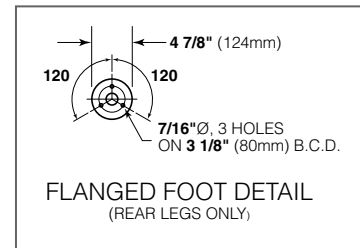

3. Seal joints of flanged feet with a silicone sealant.

WIRE CONNECTION

Note: Ensure main power is turned off before connecting wires.

General Information

Install in accordance with local codes and/or the National Electric Code ANSI/NFPA No. 70-1990 (USA) or the Canadian Electric Code CSA Standard C22.1 (Canada). A separate fused disconnect switch must be supplied and installed. The unit must be electrically grounded by the installer.

The electrical supply must match the power requirements specified on the unit's rating label. The copper wiring must be adequate to carry the required current at the rated voltage. Wire must be suitable for at least 194°F (90°C). Refer to Specification Sheet for all electrical specifications. Cleveland strongly recommends the use of liquid tight fittings.

Connection

NOTE: Wiring diagram is located under the top cover of the unit's right console.

ENSURE THE ELECTRICAL SUPPLY MATCHES THE UNIT'S REQUIREMENTS AS STATED ON THE ELECTRICAL RATING LABEL.

The supply lines will enter through the bottom of the right console and are connected to the terminal block.

WATER CONNECTION

(OPTIONAL)

A 1/2" NPT cold water line and/or a 1/2" NPT hot water line are required if unit is equipped with a single or double pantry faucet.

INSTALLATION CHECKS

Although the unit has been thoroughly tested before leaving the factory, the installer is responsible for ensuring the proper operation of unit once installed.

1. Supply power to the unit by placing the fused disconnect switch to the "ON" position.
2. Turn Temperature Dial to 150°F (66°C).
3. Toggle Power Switch to the "ON" position.
4. Heat Indicator Light (yellow) should be ON and unit heating. When temperature is reached, Yellow Indicator Light will switch OFF.
7. Turn Temperature Dial 300°F (150°C). Unit will continue to heat, Heat Indicator Light (yellow) will remain ON until temperature is reached. Then the heat indicator light will cycle off indicating the heating system has shut OFF. The heat indicator light will continue to cycle ON and OFF as the heating system cycles ON and OFF maintaining the desired temperature.
3. Toggle Power Switch to the "OFF" position.

CLEANING

After installation the unit must be thoroughly cleaned and sanitized prior to cooking. See "CLEANING INSTRUCTIONS" in this manual for complete cleaning instructions.

Caster Kit (CS-T1) for Skillet model T1

WARNING

For use only on a Cleveland Range Skillet model T1.
DO NOT attempt to use these parts on any other product. Failure to do so can cause property damage, Injury or death.

Read instructions thoroughly. Failure to do so can cause property damage, Injury or death.

This kit should be installed only by a Qualified Service Technician.

Parts Included

Item	Part Number	Description	Qty.
82	KE53046-1	Caster sleeve	4
80	KE53068-3	Caster	2
81	KE53068-4	Caster c/w brake	2
	KE55407	Warning Label	1
	KE603957	Instruction sheet, Caster T1	1
	KE003646	Strap	1

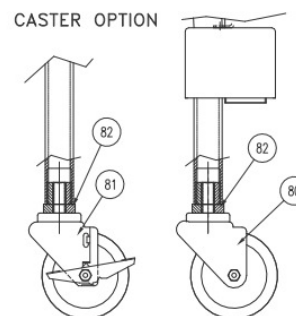

Installation Instructions

1. Disconnect electrical and or gas supplies.
2. Move unit to a location with space around it to work.
3. Jack up one end of the unit
4. Remove the feet by unscrewing.
5. Screw in the caster sleeves.
6. Screw in the Casters. Brake on front, no brake on rear.
7. Lower Skillet.
8. Repeat for other side.
9. Add Warning Label to rear leg support channel as shown.
10. Add restraint cable to unit as shown.
11. Fasten other end of restraint cable to guard against transmission of strain to the gas connector or electrical connection.
12. For gas units install gas connections using a connector complying with ANSI Z21.69 * CGA6.16 and a quick disconnect device complying with ANSI Z21.41 * CGA6.9.
13. When properly installed the strain relief will become tight and stop movement of the unit before strain is put on gas plumbing or electrical connection.



To complete installation connect unit, check for gas leaks, test unit functions.

OPERATING INSTRUCTIONS



ITEM #	DESCRIPTION	FUNCTION
1.	Power Switch	Lower position - power to the unit is OFF. Upper position - power to the unit is ON.
2.	Power Indicator Light (red)	Indicates power is ON.
3.	Temperature Dial	Regulates the surface temperature of the pan.
4.	Heat Indicator Light (yellow)	Turns ON when system is calling for heat and OFF when system is satisfied.
5.	Hand Tilt Wheel	Used for tilting the pan up or down.
6.	Power Tilt Switch	Option - Used for tilting the pan up or down.
7.	Reset Button	Fuse protection for optional power tilt.
8.	Manual Tilt Override	Used on units with optional power tilt for tilting the pan up or down in case of power or mechanical failure.
9.	Faucet (not shown)	Option - hot and/or cold faucet mounts to skillet for convenient filling of the pan.
10.	Tangent Draw-Off Valve (not shown)	Option - allows you to discharge product from the pan through the valve.

OPERATING THE UNIT

1. Ensure electrical supply to the unit is in the ON position.
2. Turn Power Switch to the ON position. The yellow Heat Indicator Light will indicate power is on.
3. **MANUAL TILT:** Cleveland skillets are equipped with a manual tilt mechanism for raising and lowering the pan. To raise pan, raise the cover and turn the crank clockwise. To lower pan, turn counter-clockwise.
POWER TILT: Cleveland skillets can also be equipped with an optional electric power tilt mechanism for raising and lowering the pan. To raise pan, raise the cover and press up on the tilt switch. To lower pan, press down on the tilt switch.
4. **FOR YOUR SAFETY:** This skillet is also equipped with a power interrupter which automatically shuts off the power to the elements whenever the skillet is raised more than 1/2" (13mm).
IMPORTANT: Before commencing to cook, ensure pan is in the lowered position by pressing down on the tilt switch. Ensure cover is raised first.
5. To preheat, set Temperature Dial to desired cooking temperature.
6. Allow skillet to preheat for approximately 15-30 minutes.
7. Once preheated, insert product in skillet and adjust Temperature Dial to required cooking temperature.
8. If desired, once product has cooked, it can be held prior to serving at a lower temperature setting.
9. When cooking is completed, set Temperature Dial and Power Switch to the OFF position.
10. The best time to clean the skillet is immediately after use, once skillet has cooled down. Refer to section titled "CLEANING INSTRUCTIONS" for details.

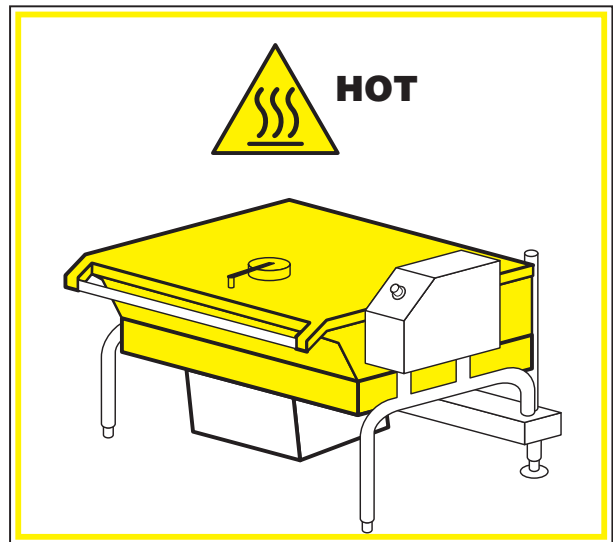
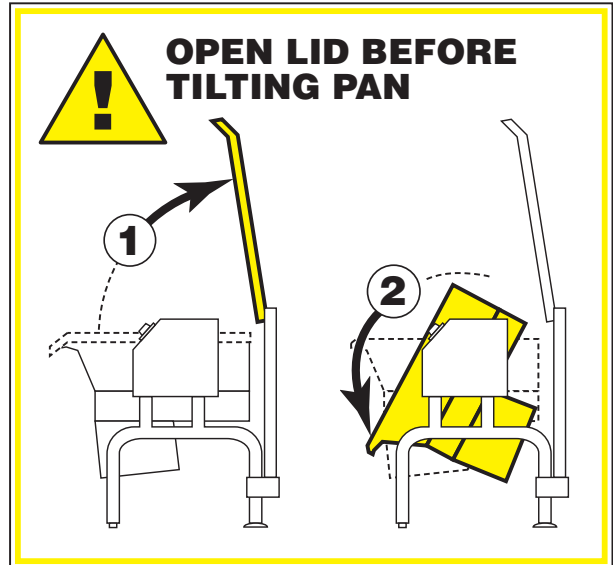

OPERATING SUGGESTION

1. Turn power switch to the "OFF" position when skillet is not in use.
2. Allow skillet to preheat before adding product.
3. Always lift the spring assist cover before activating the tilt mechanism.
4. During an electrical power interruption, turn Power Switch to the OFF position. This unit cannot be made to operate without electrical power.





CLEANING INSTRUCTIONS



CARE AND CLEANING

Cooking equipment must be cleaned regularly to maintain its fast, efficient cooking performance and to ensure its continued safe, reliable operation. The best time to clean is shortly after each use (allow unit to cool to a safe temperature).

WARNINGS

- ⇒  Do not use detergents or cleansers that are chloride based or contain quaternary salt.
Chloride Cleaners
- ⇒  Do not use a metal bristle brush or scraper.
Wire Brush &
- ⇒  Steel wool should never be used for cleaning the stainless steel.
Steel Pads
- ⇒  Unit should never be cleaned with a high pressure spray hose.
High Pressure Spray Hose
- ⇒  Do not leave water sitting in unit when not in use.
Stagnant Water

CLEANING INSTRUCTIONS

1. Turn unit off.
2. Remove drain screen (if applicable). Thoroughly wash and rinse the screen either in a sink or a dishwasher.
3. Prepare a warm water and mild detergent solution in the unit.
4. Remove food soil using a nylon brush.
5. Loosen food which is stuck by allowing it to soak at a low temperature setting.
6. Drain unit.
7. Rinse interior thoroughly.
8. If the unit is equipped with a **Tangent Draw-Off Valve**, clean as follows:
 - a) Disassemble the draw-off valve first by turning the valve knob counter-clockwise, then turning the large hex nut counter-clockwise until the valve stem is free of the valve body.
 - b) In a sink, wash and rinse the inside of the valve body using a nylon brush.
 - c) Use a nylon brush to clean tangent draw-off tube.
 - d) Rinse with fresh water.
 - e) Reassemble the draw-off valve by reversing the procedure for disassembly. The valve's hex nut should be hand tight only.
9. If the unit is equipped with a **Butterfly Valve**, clean as follows:
 - a) Place valve in open position.
 - b) Wash using a warm water and mild detergent solution.
 - c) Remove food deposits using a nylon brush.
 - d) Rinse with fresh water.
 - e) Leave valve open when unit is not in use.
10. Using mild soapy water and a damp sponge, wash the exterior, rinse, and dry.

NOTES

- ⇒ For more difficult cleaning applications one of the following can be used: alcohol, baking soda, vinegar, or a solution of ammonia in water.
- ⇒ Leave the cover off when the kettle is not in use.
- ⇒ For more detailed instructions refer to the Nafem Stainless Steel Equipment Care and Cleaning manual (supplied with unit).

STAINLESS STEEL EQUIPMENT CARE AND CLEANING

(Supplied courtesy of Nafem. For more information visit their web site at www.nafem.org)

Contrary to popular belief, stainless steels ARE susceptible to rusting.

Corrosion on metals is everywhere. It is recognized quickly on iron and steel as unsightly yellow/orange rust. Such metals are called "active" because they actively corrode in a natural environment when their atoms combine with oxygen to form rust.

Stainless steels are passive metals because they contain other metals, like chromium, nickel and manganese that stabilize the atoms. 400 series stainless steels are called ferritic, contain chromium, and are magnetic; 300 series stainless steels are called austenitic, contain chromium and nickel; and 200 series stainless, also austenitic, contains manganese, nitrogen and carbon. Austenitic types of stainless are not magnetic, and generally provide greater resistance to corrosion than ferritic types.

With 12-30 percent chromium, an invisible passive film covers the steel's surface acting as a shield against corrosion. As long as the film is intact and not broken or contaminated, the metal is passive and stain-less. If the passive film of stainless steel has been broken, equipment starts to corrode. At its end, it rusts.

Enemies of Stainless Steel

There are three basic things which can break down stainless steel's passivity layer and allow corrosion to occur.

1. Mechanical abrasion
2. Deposits and water
3. Chlorides

Mechanical abrasion means those things that will scratch a steel surface. Steel pads, wire brushes and scrapers are prime examples.

Water comes out of the faucet in varying degrees of hardness. Depending on what part of the country you live in, you may have hard or soft water. Hard water may leave spots, and when heated leave deposits behind that if left to sit, will break down the passive layer and rust stainless steel. Other deposits from food preparation and service must be properly removed.

Chlorides are found nearly everywhere. They are in water, food and table salt. One of the worst chloride perpetrators can come from household and industrial cleaners.

So what does all this mean? Don't Despair!

Here are a few steps that can help prevent stainless steel rust.

1. Use the proper tools.

When cleaning stainless steel products, use non-abrasive tools. Soft cloths and plastic scouring pads will not harm steel's passive layer. Stainless steel pads also can be used but the scrubbing motion must be in the direction of the manufacturers' polishing marks.

2. Clean with the polish lines.

Some stainless steel comes with visible polishing lines or "grain." When visible lines are present, always scrub in a motion parallel to the lines. When the grain cannot be seen, play it safe and use a soft cloth or plastic scouring pad.

3. Use alkaline, alkaline chlorinated or non-chloride containing cleaners.

While many traditional cleaners are loaded with chlorides, the industry is providing an ever-increasing choice of non-chloride cleaners. If you are not sure of chloride content in the cleaner used, contact your cleaner supplier. If your present cleaner contains chlorides, ask your supplier if they have an alternative. Avoid cleaners containing quaternary salts; it also can attack stainless steel and cause pitting and rusting.

4. Treat your water.

Though this is not always practical, softening hard water can do much to reduce deposits. There are certain filters that can be installed to remove distasteful and corrosive elements. To insure proper water treatment, call a treatment specialist.

5. Keep your food equipment clean.

Use alkaline, alkaline chlorinated or non-chloride cleaners at recommended strength. Clean frequently to avoid build-up of hard, stubborn stains. If you boil water in stainless steel equipment, remember the single most likely cause of damage is chlorides in the water. Heating cleaners that contain chlorides have a similar effect.

6. Rinse, rinse, rinse.

If chlorinated cleaners are used, rinse and wipe equipment and supplies dry immediately. The sooner you wipe off standing water, especially when it contains cleaning agents, the better. After wiping equipment down, allow it to air dry; oxygen helps maintain the stainless steel's passivity film.

7. Never use hydrochloric acid (muriatic acid) on stainless steel.

8. Regularly restore/passivate stainless steel.

Recommended cleaners for specific situations

Job	Cleaning Agent	Comments
Routine cleaning	Soap, ammonia, detergent, Medallion	Apply with cloth or sponge
Fingerprints & smears	Arcal 20, Lac-O-Nu Ecoshine	Provides barrier film
Stubborn stains & discoloration	Cameo, Talc, Zud, First Impression	Rub in direction of polish lines
Grease & fatty acids, blood, burnt-on-foods	Easy-off, De-Grease It Oven Aid	Excellent removal on all finishes
Grease & oil	Any good commercial detergent	Apply with sponge or cloth
Restoration/Passivation	Benefit, Super Sheen	

Review

1. Stainless steels rust when passivity (film-shield) breaks down as a result of scrapes, scratches, deposits and chlorides.
2. Stainless steel rust starts with pits and cracks.
3. Use the proper tools. Do not use steel pads, wire brushes or scrapers to clean stainless steel.
4. Use non-chlorinated cleaners at recommended concentrations. Use only chloride-free cleaners.
5. Soften your water. Use filters and softeners whenever possible.
6. Wipe off cleaning agent(s) and standing water as soon as possible. Prolonged contact causes eventual problems.

To learn more about chloride-stress corrosion and how to prevent it, contact the equipment manufacturer or cleaning materials supplier.

Developed by Packer Engineering, Naperville, Ill., an independent testing laboratory.

SERVICE PARTS

WARRANTY

Our Company supports a worldwide network of Maintenance and Repair Centers. Contact your nearest Maintenance and Repair Centre for replacement parts, service, or information regarding the proper maintenance and repair of your cooking equipment.

In order to preserve the various agency safety certification (UL, NSF, ASME/Ntl. Bd., etc.), only factory-supplied replacement parts should be used. The use of other than factory supplied replacement parts will void warranty.

FAUCET ASSEMBLY

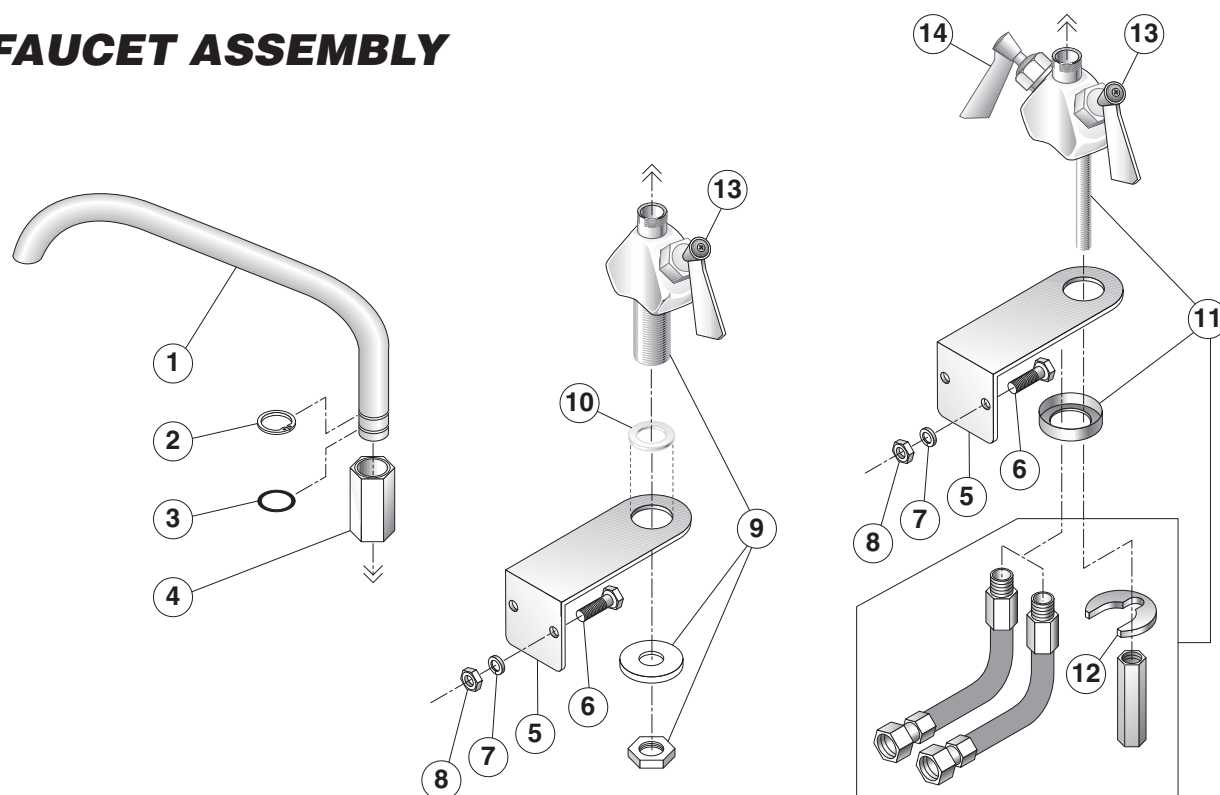

ITEM #	PART #	DESCRIPTION	QTY.
	SPK13	SINGLE PANTRY FAUCET (includes items 1-10)	
	DPK13	DOUBLE PANTRY FAUCET (includes items 1-8 & 11)	
1.	KE50825-7	3/4" SPOUT	1
2.	FA95007-10	RETAINING RING	1
3.	FA05002-19	"O" RING	1
4.	KE51736	LONG FAUCET NUT	1
5.	SK00395-1	FAUCET MOUNTING BRACKET	1
6.	FA11258	HEX CAP SCREW	2
7.	FA31029	LOCK WASHER	2
8.	FA210028	HEX NUT	2
9.	KE51401	SINGLE PANTRY BODY (c/w item 13)	1
10.	KE50335	ADAPTER WASHER	1
11.	KE51403	DOUBLE PANTRY BODY (c/w item 13 & 14)	1
12.	SE50447	REPLACEMENT HORSESHOE WASHER	1
13.	SE50021	REPLACEMENT STEM ASSEMBLY, COLD WATER	1
14.	SE50020	REPLACEMENT STEM ASSEMBLY, HOT WATER	1

FRAME / LID ASSEMBLY

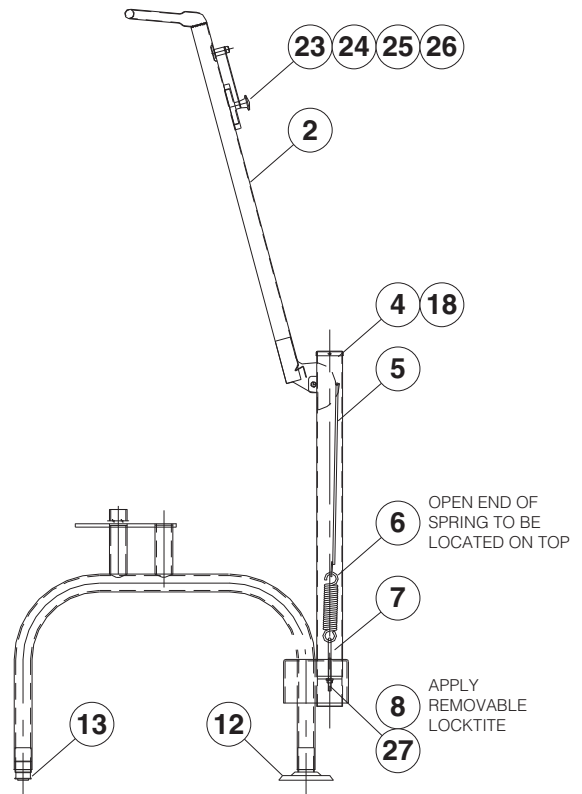
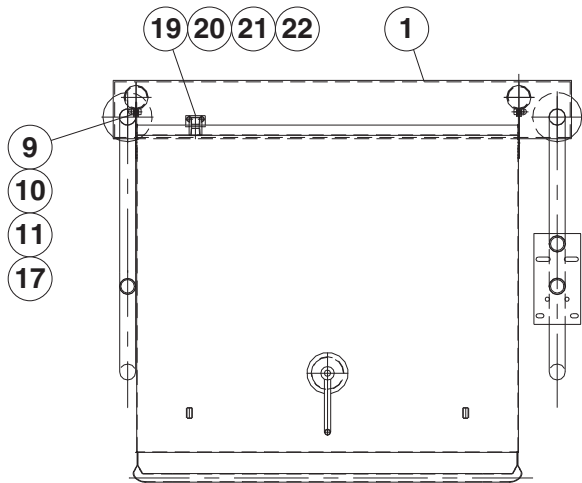

ITEM NO.	PART NO.	DESCRIPTION	QTY.
1.	SK00392-1	FRAME WELDMENT (30 GALLON)	.1
	SK00392-3	FRAME WELDMENT (40 GALLON)	.1
2.	SK2457192	LID ASSEMBLY (30 GALLON)	.1
	SK2457193	LID ASSEMBLY (40 GALLON)	.1
4.	KE50187-1	CAP	.2
5.	SK00394-1	HOOK WELDMENT	.2
6.	SK2452300	SPRING	.2
7.	FA95087-1	EYE BOLT	.2
8.	FA20008	HEX NUT	.2
9.	KE53573-1	BEARING	.2
10.	FA15019-4	SHOULDER BOLT	.2
11.	FA21501-2	ACORN NUT	.2
12.	KE00099	ADJUSTABLE FOOT (FLANGED)	.2
13.	KE50249-1	FOOT ADJUSTOR (W/O FLANGE)	.2
17.	FA31029	LOCKWASHER	.2
18.	FA11054	SCREW	.4
19.	SK2459299	COUPLING ASSEMBLY	.1
20.	FA21024	HEX NUT (5/16-18)	.2
21.	FA31030	LOCKWASHER	.2
22.	FA30055	FLAT WASHER	.2
23.	SK00054	VENT COVER ASSEMBLY	.1
24.	SK2211200	SPACER	.1
25.	FA95081-1	BOLT, MODIFIED	.1
26.	SK50179	WASHER	.1
27.	FA30504	WASHER	.2

2" TANGENT DRAW-OFF VALVE

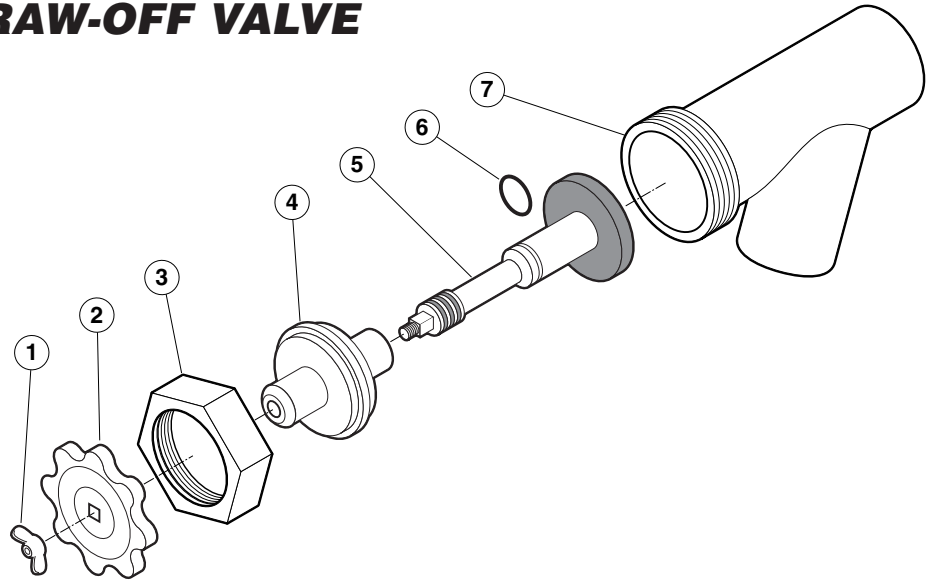

ITEM NO.	PART NO.	DESCRIPTION	QTY.
1. - 7.	KE50972-B	DRAW-OFF ASSEMBLY	1
1.	FA95049	WING NUT	1
2.	KE527551	KNOB	1
3.	KE52754	HEX NUT	1
4.	KE52753	RETAINER	1
5.	KE52752	PISTON	1
6.	FA00111	"O" RING	1
7.	KE52751	VALVE BODY	2

TILT COMPONENTS

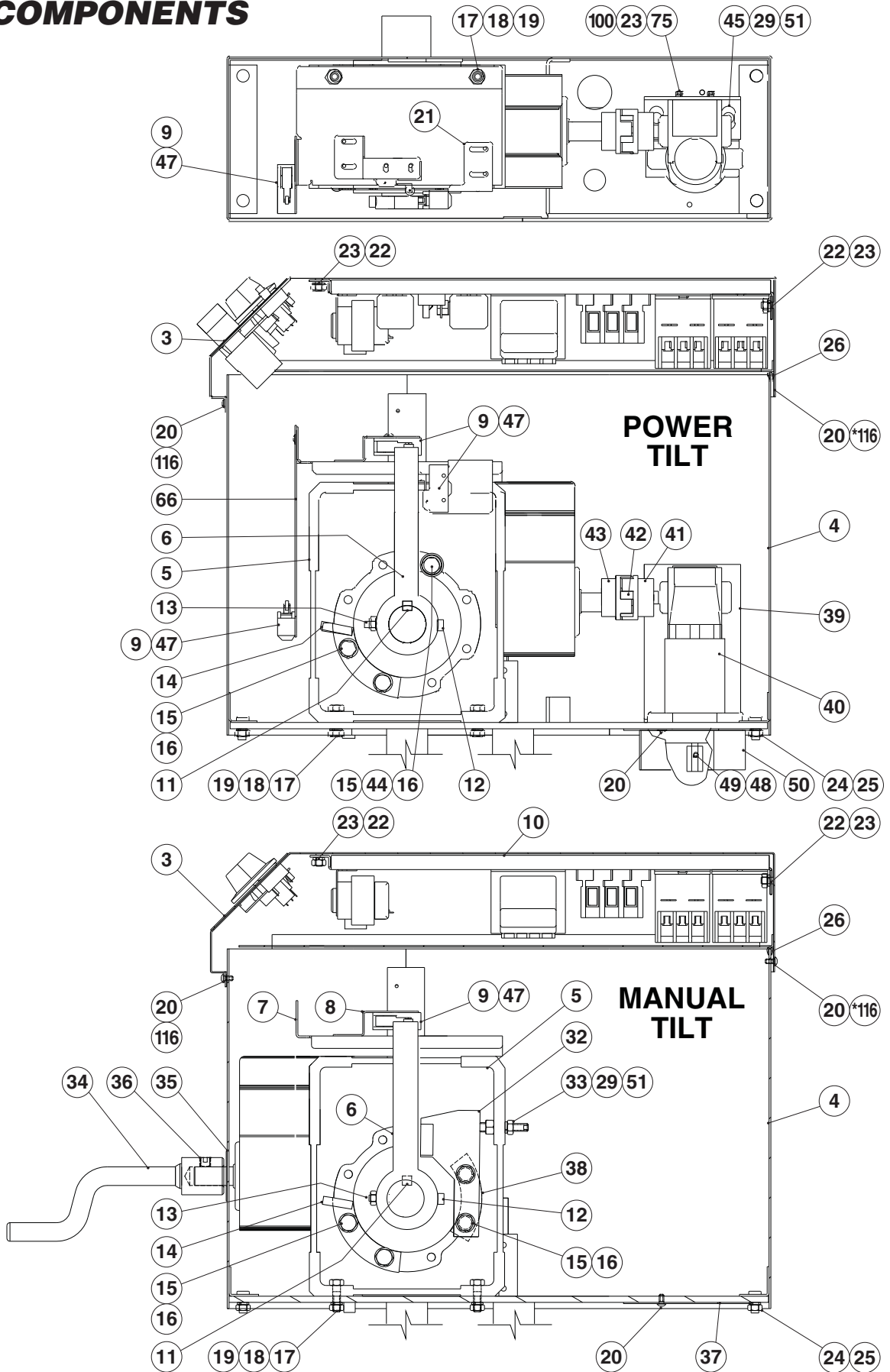

TILT COMPONENTS

ITEM NO.	PART NO.	DESCRIPTION	QTY.
3.	REF.SK00387	GEARBOX COVER ASSEMBLY	1
4.	KE002590	WRAP WELDMENT FOR GEAR	1
5.	KE55513	GEAR BOX	1
6.	KE602239	STOP ARM	1
7.	KE602587	SAFETY MOUNTING BRACKET	1
8.	KE602598	MOUNTING BRACKET	1
9.	SK2474500	SWTCH, TILT LIMIT	1
10.	REF.SK00410	COMPONENT PLATE ASSEMBLY	1
11.	FA95055-13	KEY, 3/8 X 3/8 X 5	1
12.	FA15019-6	SHOULDER BOLT	1
13.	FA21024	5-16 HEX NUT, 18-8 S.S.	1
14.	KE002527	STOP ASSEMBLY	1
15.	FA15021	BOLT, HEX CAP M10 X 30	2
16.	FA31500	LOCKWASHER, M10	2
17.	FA11526	HEX. CAP SCREW, 7/16-14 X 1-1/4" S.S. 18-8	6
18.	FA31011	7/16 SPLIT LOCKWASHER, S.S. 18-8	6
19.	FA21506	NUT, 7/16-14 S.S. 18-8	6
20.	FA11135	SCREW, 10-24 X 1/2	7
21.	KE602573	MOUNTING BRACKET	1
22.	FA21008	HEX. NUT, 1/4-20	6
23.	FA31029	SPLIT LOCKWASHER, 1/4	6
24.	FA21024	5/16 - 18, HEX NUT, 18-8 S.S.	4
25.	FA31030	SPLIT LOCKWASHER, 5/16	4
26.	KE600284-4	GASKET, SILICONE GRAY	1
29.	FA31031	SPLIT LOCKWAHER	2
32.	KE002215	STOP ARM	1
33.	FA19196	SET SCREW, 3/8-16 X 2 1/2"	1
34.	KE002509	HAND CRANK ASSEMBLY	1
35.	KE54738-5	WASHER, FLAT	1
36.	FA19505	SET SCREW, 3/8-24 X 3/8"	1
37.	KE602511	BOTTOM COVER	1
38.	KE602032	SPACER	1
39.	KE601725	SUPPORT	1
40.	KE52832-5	MOTOR, POWER TILT	1
41.	KE50582-5	COUPLING HUB, 1/2 BORE	1
42.	KE50583-1	COUPLING SPIDER	1
43.	KE50582-4	COUPLING HUB, 3/4 BORE	1
44.	KE601886	STOP	1
45.	FA11384	HEX. CAP SCREW, 3/8-16 X 1"	2
47.	FA10140	SCREW, 6-32 X 1 1/4	2
48.	KE602542	EXTENSION FOR SHAFT	1
49.	KE602543	SOCKET SET SCREW, CONE POINT	1
50.	KE602507	BOTTOM COVER	1
51.	FA21026	3/8 HEXAGON NUT	2
66.	KE602571	MOUNTING BRACKET	1
75.	FA11258	1/4-20 X 3/4 BOLT, 18-8 S.S.	4
100.	FA30505-1	FLAT WASHER, 1/4	4
116.	FA11511-2	10-32 X 3/8 PAN HEAD TORX SCREW	1

CONTROL BOX ASSEMBLY

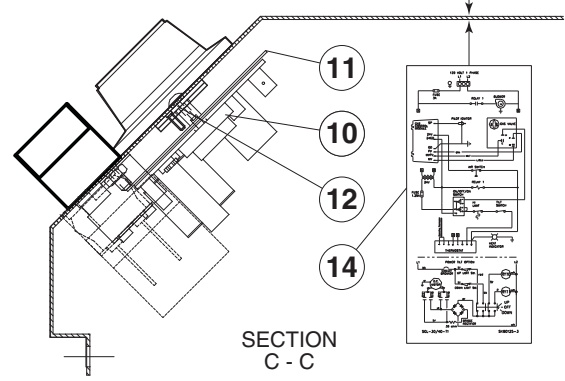
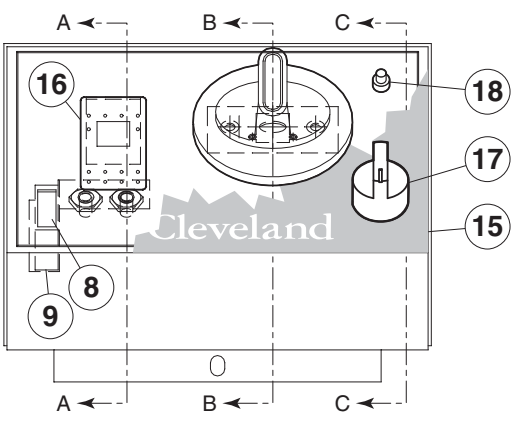
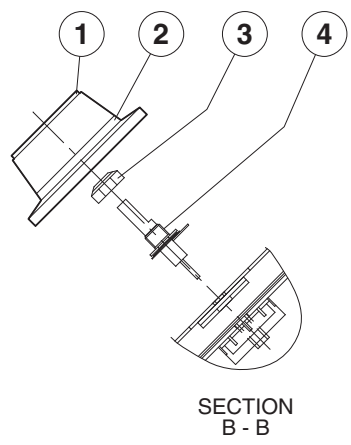
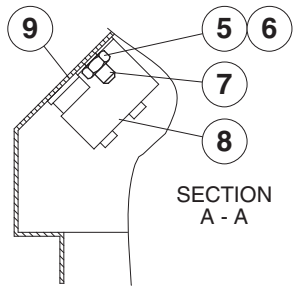

ITEM NO.	PART NO.	DESCRIPTION	QTY.
1.	SK2138700	KNOB ASSEMBLY	1
2.	SK2360700	DIAL INSERT °F	1
	SK2360701	DIAL INSERT °C	1
3.	KE51005	RUBBER BOOT. #N9030 X 1/4	1
4.	SK2498399	POTENTIOMETER SHAFT ASSEMBLY	1
	SK2166800	POTENTIOMETER SHAFT	1
	SK2167000	TENSION PIN	1
	SK2167100	WASHER, BOWED/SPRING	1
	SK2167200	RETAINING RING, SP-NR #R1000-25	1
	SK2167300	PANEL BEARING	1
	SK2382800	RETAINING RING CLIP	1
5.	FA21006	NUT, S.S. F#10-24	2
6.	FA32022	TOOTH LOCK WASHER #10 S.S.	2
7.	FA40000-6	#10-24 X 3/8 S.S. WELD STUD	2
8.	SK50903-1	BRACKET, INDICATOR LIGHT	1
9.	SK50905-1	HEAT INDICATOR, 28V	1
10.	SK2142002	THERMOSTAT	1
11.	SK2159300	THERMOSTAT INSULATOR	1
12.	SK2491500	STOP PLATE ASSEMBLY	1
13.	SK95063	CAUTION LABEL	1
14.	SK90126-2	WIRING DIAGRAM	1
15.	KE95604-3	CONTROLS LABEL, MANUAL TILT	1
	KE95604-4	CONTROLS LABEL, POWER TILT	1
16.	SK2474102	SWITCH, ON/OFF/ON, DUAL FIRING	1
17.	KE53137-3	TILT SWITCH, ON/OFF/ON	1
	KE53184	CONTACT SECTION HOLDER (LATCH)	1
	KE53138-1	CONTACT BLOCK	4
18.	KE50579-2	CIRCUIT BREAKER	1
	FA05002-34	"O" RING, CIRCUIT BREAKER	1
	KE50580	WATER RESISTANT BOOT	1

INCLUDES

COMPONENT PLATE ASSEMBLY

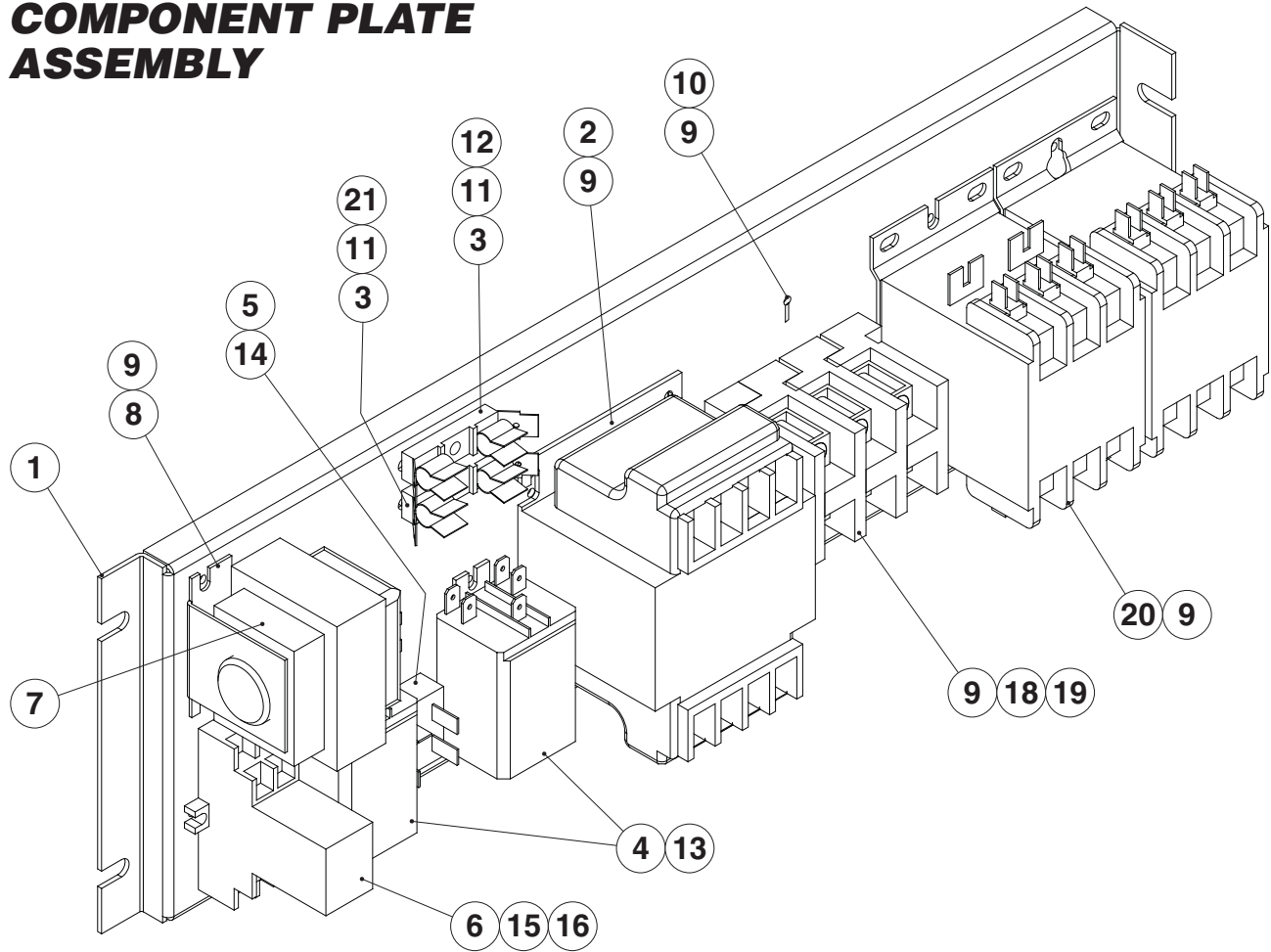

ITEM NO.	PART NO.	DESCRIPTION	QTY.
1.	KE602092	COMPONENT PLATE	1
2.	KE53838-10	TRANSFORMER	1
3.	KE51139	FUSE HOLDER	2
4.	KE50753-10	RELAY, DTDP / 10A / 120VAC	2
5.	KE50581	BRIDGE RECTIFIER	1
6.	SK2475500	RELAY	1
7.	KE53838-25	TRANSFORMER	1
8.	KE53444	BRACKET, TRANSFORMER MOUNTING	1
9.	F10	8-32 X 3/8	3
10.	KE50473	GROUND LUG	1
11.	FA904	6-32 x 5/8	2
12.	KE52936-8	FUSE, 1.25 AMP.	1
14.	FA15018-8	8-32 X 1	1
15.	SK2475600	HOLDER	1
16.	SK2475700	SPRING	1
17.	F904	6-32 X 5/8	2
18.	KE50577	TERMINAL BLOCK	3
19.	KE50576	END	1
20.	KE50750-7	CONTACTOR	2
21.	KE52936-6	FUSE, 3 AMP	1

PAN MOUNT ASSEMBLY

ITEM NO.	PART NO.	DESCRIPTION	QTY.
1.		HEATING ELEMENTS	6
	30 GALLON		
	SK50845-1	ELEMENT, 2.00 KW, 480 VAC	
	SK50845-2	ELEMENT, 2.67 KW, 416 VAC	
	SK50845-3	ELEMENT, 2.00 KW, 416 VAC	
	SK50845-4	ELEMENT, 2.67 KW, 240 VAC	
		ELEMENT, 2.00 KW, 208 VAC	
	SK50845-5	ELEMENT, 2.00 KW, 240 VAC	
	SK50845-6	ELEMENT, 2.67 KW, 208 VAC	
	SK50845-8	ELEMENT, 2.67 KW, 480 VAC	
	40 GALLON		
	SK50861-1	ELEMENT, 4.00 KW, 480 VAC	
	SK50861-2	ELEMENT, 3.00 KW, 480 VAC	
	SK50861-3	ELEMENT, 4.00 KW, 416 VAC	
	SK50861-4	ELEMENT, 3.00 KW, 416 VAC	
	SK50861-5	ELEMENT, 4.00 KW, 240 VAC	
		ELEMENT, 3.00 KW, 208 VAC	
	SK50861-6	ELEMENT, 3.00 KW, 240 VAC	
	SK50861-7	ELEMENT, 4.00 KW, 208 VAC	
3.	SK50932	BRACKET FOR THERMOCOUPLE ...	1
4.	SK50958-1	CLAMPING PLATE	1
5.	SK50959-1	INSULATION	1
6.	SK50960-1	ELEMENT COVER	1
7.	SK50862-1	TRIM	1
8.	SK50961	ELECTRIC BOX WRAP	1
9.	SK50850-1	ELECTRICAL BOX COVER	1
10.	SK50965	SIDE BOX COVER	1
11.	SK2489001	LIQUID TIGHT FITTING	1
12.	SK2490600	FULL COUPLING S.S.	1
13.	SK2487800	BAYONET, ADAPTER	1
14.	SK00409	SIDE BOX ASSEMBLY	1
15.	SK50963	BRACKET	1
16.	SK50962	THERMOCOUPLE COVER	1
17.	F95	PALNUT91
18.	FA11144	SCREW, S.S. 10-32 X 1/446
19.	FA21008	HEX. NUT 1/4-203
20.	FA30505-1	WASHER, 1/43
21.	SK50933-1	SENSOR	1
22.	FA30505-3	WASHER	1
23.	KE55069-7	HIGH LIMIT	1
24.	SK50908-1	INSULATION, ELECTRICAL BOX ...	2
26.	KE55247	SILICON WASHER	2
27.	KE53735	WASHER	1
28.	54833-4	SNAP-IN BUSHING	2
29.	FA95088	HEX FLANGE, SCREW, 10-32 X 1/2	.2

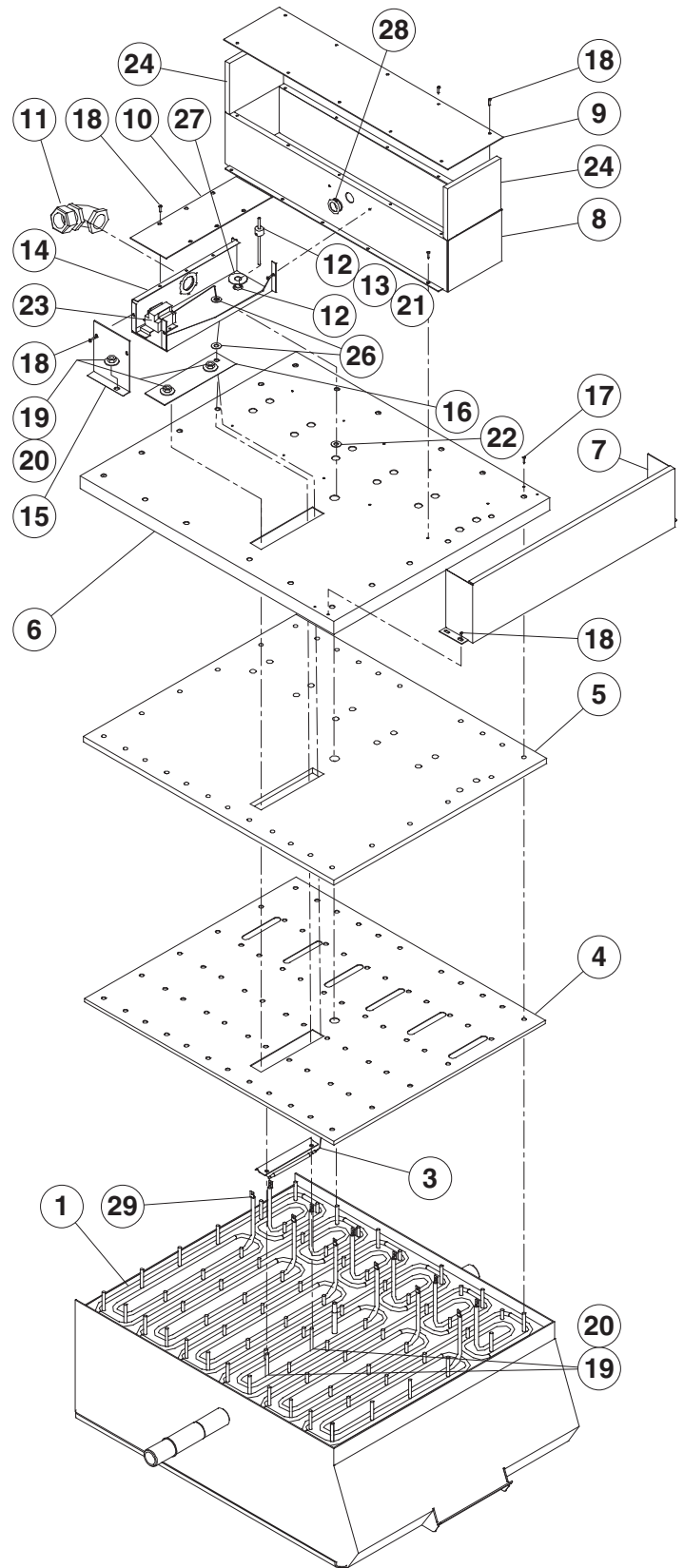

MAINTENANCE



WARNING:

Any maintenance or service involving disassembly of components should be made by a qualified service technician. Ensure electrical and water supply (if applicable) to the unit are shut off.

HINGE ADJUSTMENT INSTRUCTIONS

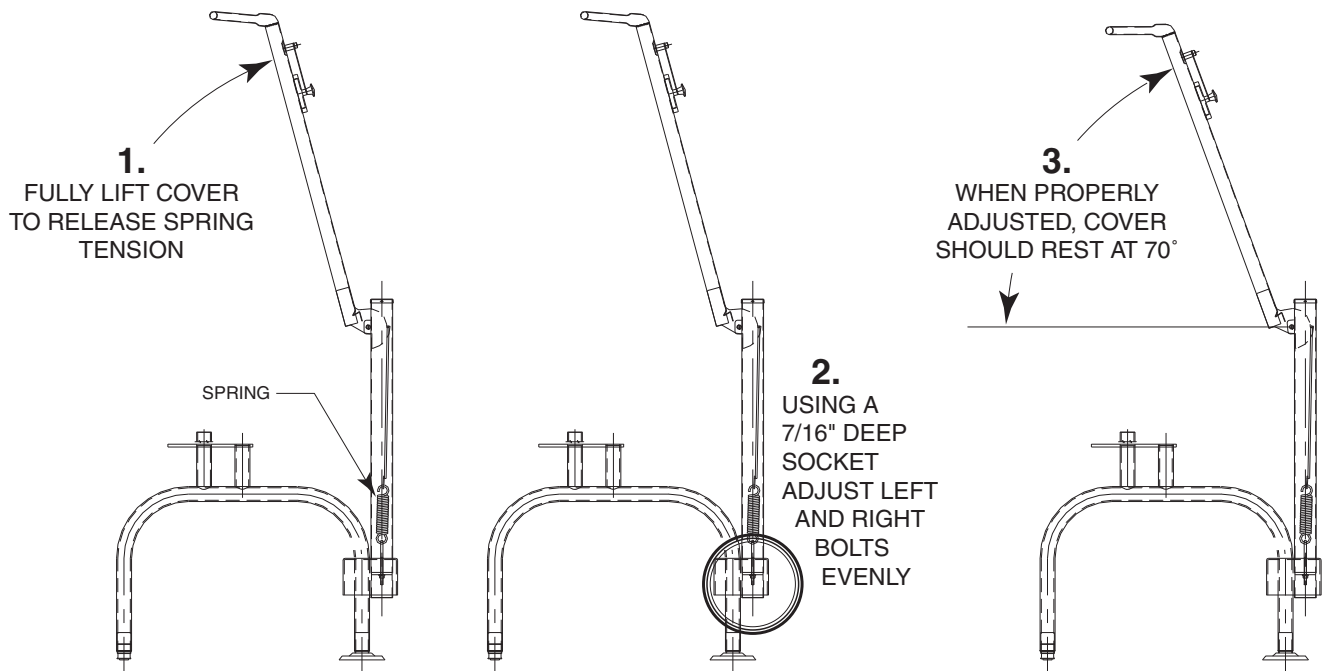

LUBRICATION PROCEDURE

Lubricate the following parts every three months to insure smooth operation and reduce wear.

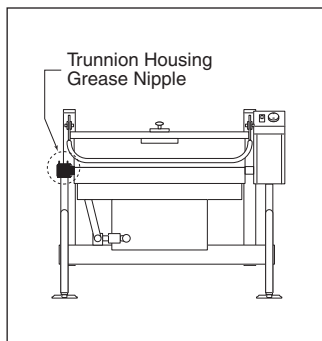

TRUNNIONS

On the left hand side of the skillet there are two grease nipples on the top back portion of the trunnion housing.

SEQUENCE OF OPERATIONS

When using these instructions refer to the SEL-TI wiring schematic.

1. Supply Voltage is sent to the primary of the 120 VAC transformer.
2. Supply voltage is sent to the normally open contacts of the Heat Contactors, C1 and C2.
3. 120 VAC is sent from the secondary of the 120VAC transformer through the 3 amp fuse to
 - The primary of the 24 VAC transformer
 - 24 VAC is sent from the secondary of the 24VAC transformer through the 1.25 amp fuse to the on/off switch.
 - Contacts of the R1 Heat Relay
4. 120 VAC is sent from the secondary of the 120 VAC transformer to the optional Power Tilt Circuit (See step 9).
5. With the On/Off switch in the On position.
 - 24 VAC is sent through the normally closed high limit switch to the mercury switch..
 - If the skillet is in the down position then 24 VAC is sent through mercury switch to pin 9 on the thermostat.
6. If the steamer is calling for heat the 24 VAC is sent from pin number 10 to RI Heat Relay.
 - The normally open contacts of the Heat relay close sending 120 VAC to the Heat contactor coils C 1 and C2.
7. The Contactor close and supply Voltage is sent to the elements.
 - The elements heat until the thermostat is satisfied.
8. When thermostat is satisfied, 24 VAC is removed from pin 10 on the thermostat and the heat circuit is de-energized.
9. If the skillet has the optional Power Tilt option and is in the down position, 120 VAC is sent from the secondary of the 120 VAC transformer through the circuit breaker and the up limit switch to the tilt switch.
10. With the tilt switch in switch in the Up position
 - 120 VAC is sent to the Bridge Rectifier
 - 115 VDC is sent from the rectifier through the 30-ohm resistor to the normally open RY10 and RYI I relay contacts.
 - 120 VAC is sent to the RY10 relay coil.
 - The normally open RY10 contact close and 90 VDC is sent to the DC motor
 - The DC motor is energized and the skillet tilts until the switch is released or the up limit switch opens.
11. With the Tilt switch in the Down position
 - 120 VAC is sent to the Bridge Rectifier
 - 115 DC is sent from the rectifier to the normally open RY 10 and RY 11 relay contacts.
 - 120 VAC is sent to the RY11 relay coil.
 - The normally open RY 11 contact close and the polarity of the 90 VDC is reversed.
 - The DC motor is energized and the skillet lowers until the switch is released or

POWER TILT MANUAL OVERRIDE

In case of power failure or malfunction the skillet pan can be tilted manually following these instructions.

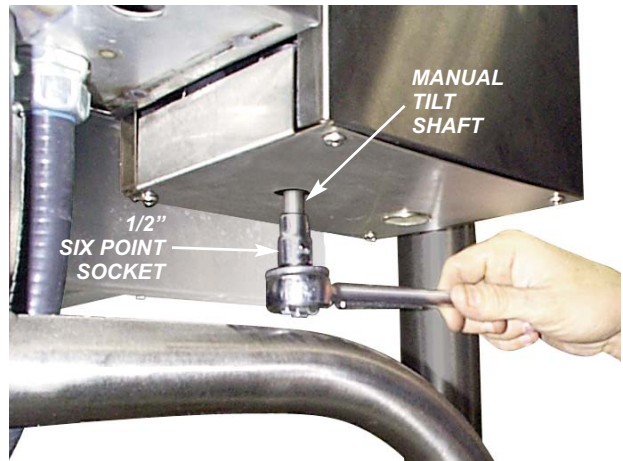

1. Fit a 1/2" SIX POINT SOCKET over the MANUAL TILT SHAFT as shown above.
2. Turn socket wrench clockwise to empty contents.

SPARE PARTS LIST

PART NO.	DESCRIPTION	QTY.
HEATING ELEMENTS		6
<i>30 GALLON</i>		
SK50845-1	ELEMENT, 2.00 KW, 480 VAC	
SK50845-2	ELEMENT, 2.67 KW, 416 VAC	
SK50845-3	ELEMENT, 2.00 KW, 416 VAC	
SK50845-4	ELEMENT, 2.67 KW, 240 VAC	
	ELEMENT, 2.00 KW, 208 VAC	
SK50845-5	ELEMENT, 2.00 KW, 240 VAC	
SK50845-6	ELEMENT, 2.67 KW, 208 VAC	
SK50845-8	ELEMENT, 2.67 KW, 480 VAC	
<i>40 GALLON</i>		
SK50861-1	ELEMENT, 4.00 KW, 480 VAC	
SK50861-2	ELEMENT, 3.00 KW, 480 VAC	
SK50861-3	ELEMENT, 4.00 KW, 416 VAC	
SK50861-4	ELEMENT, 3.00 KW, 416 VAC	
SK50861-5	ELEMENT, 4.00 KW, 240 VAC	
	ELEMENT, 3.00 KW, 208 VAC	
SK50861-6	ELEMENT, 3.00 KW, 240 VAC	
SK50861-7	ELEMENT, 4.00 KW, 208 VAC	
SK2474500	SWTCH, TILT LIMIT	1
SK50933-1	SENSOR	1
KE55069-7	SAFETY THERMOSTAT	1
SK2475500	RELAY	1
KE50750-7	CONTACTOR	2
KE53838-10	TRANSFORMER, 208-240V, 480V	1
KE53838-11	TRANSFORMER, 380-415V	1
KE53838-25	TRANSFORMER	1
KE52936-8	FUSE, 1.25 AMP	1
KE52936-6	FUSE, 3 AMP	1
SK2498399	POTENTIOMETER SHAFT ASSEMBLY	1
	<i>INCLUDES:</i>	
SK2166800	POTENTIOMETER SHAFT	1
SK2167000	TENSION PIN	1
SK2167100	WASHER, BOWED/SPRING	1
SK2167200	RETAINING RING, SP-NR #R1000-25	1
SK2167300	PANEL BEARING	1
SK2382800	RETAINING RING CLIP	1
SK50905-1	HEAT INDICATOR, 28V	1
SK2142002	THERMOSTAT	1
SK2474103	SWITCH, POWER ON/OFF	1
FA15019-6	SHOULDER BOLT	1
FA21024	5-16 HEX NUT, 18-8 S.S.	1
POWER TILT ONLY		
KE53137-3	TILT SWITCH, ON/OFF/ON	1
KE53184	CONTACT SECTION HOLDER (LATCH)	1
KE53138-1	CONTACT BLOCK	4
KE50579-2	CIRCUIT BREAKER	1
FA05002-34	"O" RING, CIRCUIT BREAKER	1
KE50580	WATER RESISTANT BOOT	1

WIRING DIAGRAM

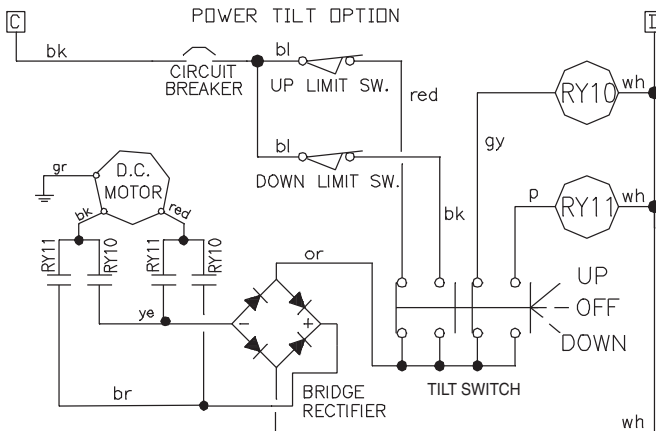
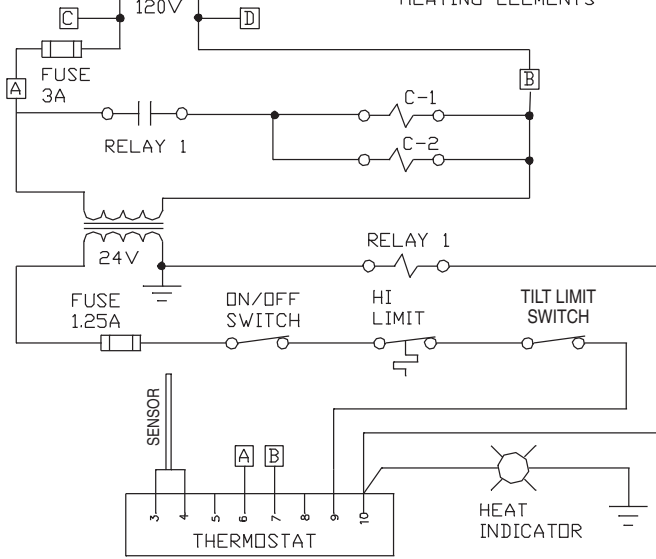
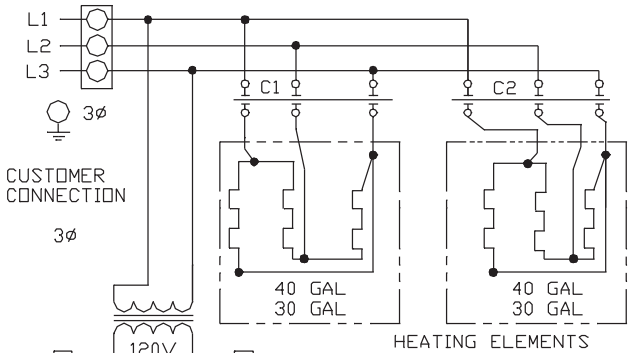
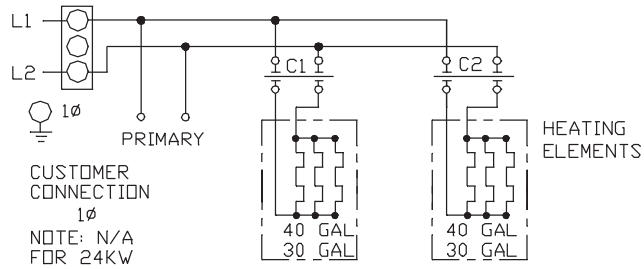

ELECTRICAL COMPONENT PART #s

FUSE 3A	KE52936-6
FUSE 1.25A	KE52936-8
RELAY 1	SK2475500

HEATING ELEMENTS -

SEE "PAN MOUNT ASSEMBLY"

ON/OFF SWITCH	SK2474102
HIGH LIMIT	KE55069-7
THERMOSTAT	SK2142002
SENSOR	SK50933-1
HEAT INDICATOR	SK50905-1
CIRCUIT BREAKER	KE50579-2
TILT LIMIT SWITCH	SK2474500
RY10 (RELAY)	KE50753-10
RY11 (RELAY)	KE50753-10
DC MOTOR	KE52832-5
BRIDGE RECTIFIER	KE50581
TILT SWITCH	KE53137-3
- SECTION	KE53184
- CONTACT BLOCK	KE53138-1