

HUSSMANN®



BCH Medium Temperature Merchandisers

**Models: BCH-8S and BCH-18 (1 Door)
BCH-45 (2 Door) and BCH-68 (3 Door)**



Installation & Service Manual

IMPORTANT
Keep in store for
future reference!

P/N 2402474_F
April 2013

ATTENTION

Merchandiser must operate for 24 hours
before loading product!

Regularly check merchandiser temperatures.

Do not break the cold chain. Keep products
in cooler before loading into merchandiser.

These merchandisers are designed
for pre-chilled products only.



IMPORTANT
KEEP IN STORE FOR FUTURE REFERENCE
Quality that sets industry standards!

HUSSMANN® 12999 St. Charles Rock Road • Bridgeton, MO 63044-2483
U.S. & Canada 1-800-922-1919 • Mexico 1-800-890-2900

www.hussmann.com

© 2013 Hussmann Corporation

TABLE OF CONTENTS

ANSI DEFINITIONS vi

SERVICE

INSTALLATION

NSF Certification 1-1
Husmann Product Control 1-1
Location 1-1
Shipping Damage 1-1
Self Contained Location 1-2
Unloading 1-3
Exterior Loading 1-3
Shipping Skid 1-3
Cabinet Leveling 1-4
Sealing Merchandiser to Floor 1-4
Door Seal 1-5
Serial Plate Location 1-5
Refrigeration Unit Access 1-5
Shelf Installation 1-6
Lamps 1-7
Door Switch 1-7
Stocking 1-8
Load Limits 1-8

Replacing Fluorescent Lamps 5-1
Replacing Display Lamp 5-1
Replacing Interior Lamps 5-1
Replacing Electronic Ballasts 5-2

APPENDIX A

Part Numbers A-1
Dimensions A-3
Refrigeration Data A-4
Electrical Data A-5

WARRANTY

ELECTRICAL / REFRIGERATION

Plug 2-1
Refrigeration 2-2
Temperature Control 2-2
Electronic Control 2-2
Controls and Adjustments 2-3
Defrost Water Evaporation 2-4
Installing FDA/NSF Thermometer 2-4

MAINTENANCE

Care and Cleaning 4-1
Exterior Surfaces 4-1
Interior Surfaces 4-1
Cleaning Shelves 4-2
Cleaning Coils 4-2
Cleaning Wash Out Drain 4-3
Tips and Trouble Shooting 4-4

REVISION HISTORY

REVISION F — APRIL 2013

Changed Compressor HP, Page A-3 and A-4

REVISION E — FEBRUARY 2013



Changed to letter “E” for Engineering purposes

REVISION B — DECEMBER 2010

- Added Air Flow Drawing, Page, 1-2
- Added Serial Plate Location, Page 1-5
- Added LED Locking Plug, Page 2-1
- Added Door Switch, Page 1-7
- Added Appendix A

ORIGINAL ISSUE — MARCH 2010

ANSI Z535.5 DEFINITIONS

-  • **DANGER** – Indicate[s] a hazardous situation which, if not avoided, will result in death or serious injury.
-  • **WARNING** – Indicate[s] a hazardous situation which, if not avoided, could result in death or serious injury.
-  • **CAUTION** – Indicate[s] a hazardous situation which, if not avoided, could result in minor or moderate injury.
- **NOTICE** – *Not related to personal injury* – Indicates[s] situations, which if not avoided, could result in damage to equipment.

INSTALLATION

NSF CERTIFICATION

These merchandisers are manufactured to meet ANSI / National Sanitation Foundation (NSF[®]) Standard #7 requirements. Proper installation is required to maintain certification. Near the serial plate, each case carries a label identifying the type of application for which the case was certified.

ANSI/NSF-7 Type I - Display Refrigerator / Freezer
Intended for 75°F / 55% RH Ambient Application

ANSI/NSF-7 Type II - Display Refrigerator / Freezer
Intended for 80°F / 55% RH Ambient Application

ANSI/NSF-7 - Display Refrigerator
Intended for Bulk Produce

Placing refrigerated merchandisers in direct sunlight, near hot tables or near other heat sources could impair their efficiency. Like other merchandisers, these self-contained units are sensitive to air disturbances. Air currents passing around merchandisers will seriously impair their operation. Do NOT allow air conditioning, electric fans, open doors or windows, etc. to create air currents around the case. *BCH units take in air and exhaust air through the front of the case, and require no clearance space on top, at the back or either side.*

Product should always be maintained at proper temperature. This means that from the time the product is received, through storage, preparation and display, the temperature of the product must be controlled to maximize the life of the product.

HUSSMANN PRODUCT CONTROL

The serial number and shipping date of all equipment is recorded in Hussmann's files for warranty and replacement part purposes. All correspondence pertaining to warranty or parts ordering must include the serial number of each piece of equipment involved. This is to ensure the customer is provided with the correct parts.

LOCATION

These merchandisers are designed for displaying products in air conditioned stores where temperature is maintained at or below the ANSI / NSF-7 specified level and relative humidity is maintained at or below 55%.

Recommended operating ambient temperature is between 65° F (18° C) with a maximum 55% relative humidity to 80 F (26° C) with a maximum 55% relative humidity.

SHIPPING DAMAGE

All equipment should be thoroughly examined for shipping damage before and during unloading. This equipment has been carefully inspected at our factory. Any claim for loss or damage must be made to the carrier. The carrier will provide any necessary inspection reports and/or claim forms.

Apparent Loss or Damage

If there is an obvious loss or damage, it must be noted on the freight bill or express receipt and signed by the carrier's agent; otherwise, carrier may refuse claim.

Concealed Loss or Damage

When loss or damage is not apparent until after equipment is uncrated, retain all packing materials and submit a written response to the carrier for inspection, within 15 days.

1-2 INSTALLATION

SELF CONTAINED (LOCATION)

BE SURE TO POSITION SELF CONTAINED MERCHANDISERS PROPERLY.

SELF CONTAINED models have vented base panels to allow air circulation through the condensing unit.

Allow for a minimum 36 in. clearance in the front. Blocking or restricting air flow will adversely affect performance and may damage the refrigeration system.

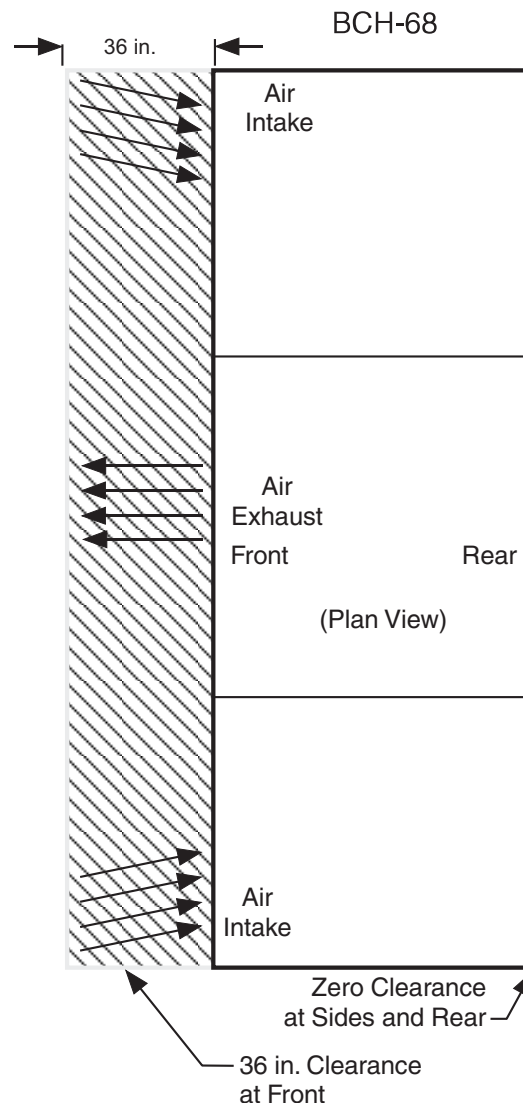
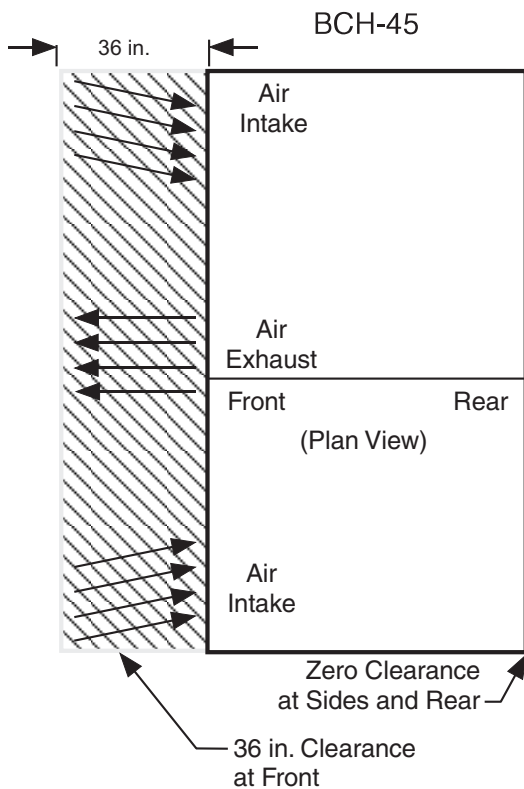
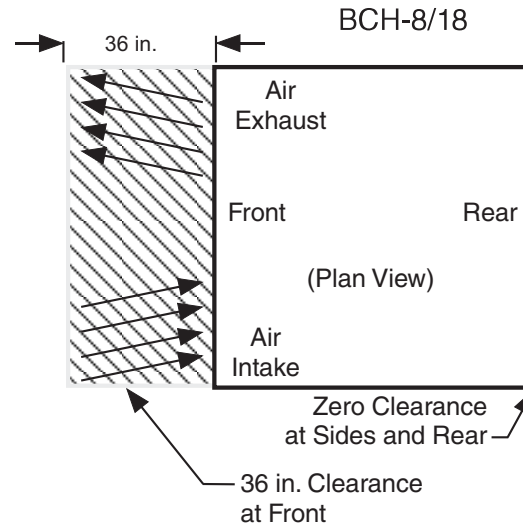

UNLOADING

Unloading from Trailer:

Lever Bar (also known as a Mule, Johnson Bar, J-Bar, Lever Dolly, or Pry Lever)

Move the merchandiser as close as possible to its permanent location and remove all packaging. Check for damage before discarding packaging. Remove all separately packed accessories such as kits and shelves.

Improper handling may cause damage to the merchandiser when unloading. To avoid damage:

1. Do not drag the merchandiser out of the trailer. Use a Johnson bar (mule).
2. Use a forklift or dolly to remove the merchandiser from the trailer.



EXTERIOR LOADING

Do **NOT** walk on top of the merchandiser or damage to the merchandisers and serious personal injury could occur.

MERCHANDISERS ARE NOT STRUCTURALLY DESIGNED TO SUPPORT EXCESSIVE EXTERNAL LOADING such as the weight of a person. Do not place heavy objects on the merchandiser.

SHIPPING SKID

Each merchandiser is shipped on a skid to protect the merchandiser's base and to make positioning the case easier..

Remove the top of the crate and detach walls from each other. Lift crate from the skid. Unscrew the case from the skid. The merchandiser can now be lifted off the crate skid. ***Lift only at base of skid!*** Remove any braces and/or skids attached (blanket wrapped merchandiser may have skids).

DO NOT TILT MERCHANDISER ON ITS SIDE OR END WHEN REMOVING SKID.

Once the skid is removed, the merchandiser must be lifted —**NOT PUSHED**— to reposition. To remove the skid, remove screws attaching skid to the merchandiser.

Check floor where merchandisers are to be set to if it is a level area.



CABINET LEVELING

This merchandiser must be installed level (from back to front, and side to side) to allow maximum draining of the condensate water as well as proper door alignment and operation. Choose a level area to install case.

BCH-8S and BCH-18 cases have one adjustable cabinet foot at each bottom corner for easy adjustment if required. BCH-45 and BCH-68 also have an adjustable foot at center front and back. Turn the foot levelers clockwise to add length to each foot for leveling.

When optional 6-inch legs are used, screw the legs tight to the merchandiser base and then adjust the feet.

When optional casters are used, screw them tight to the merchandiser base. Once in final position, lock each caster.

Thumbscrew Lock



Lock Each Caster

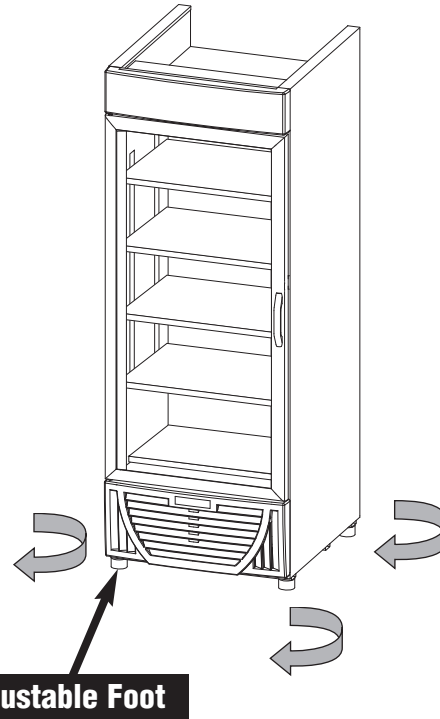

SEALING MERCHANDISER TO FLOOR

If required by local sanitary codes, or if the customer desires, merchandisers may be sealed to the floor using a vinyl cove base trim. The size needed will depend on how much variation there is in the floor, from one end of the merchandiser to the other. Sealing of the lower front and rear panels on self contained models may hamper their removal for servicing or maintenance of the condensing unit.

NOTE: Do not allow trim to cover any intake or discharge grilles located in the lower front panel.

DOOR SEAL

Check that hinge doors close automatically by opening the door 45 degrees and releasing. Ensure door closes and gasket seals door shut. To adjust the torque applied to the hinged door:

1. Place a wrench on each of the two lower support nuts located at the bottom hinge.
2. Loosen the lower nut while holding the upper nut in place.
3. Torque is increased or decreased by rotating the top nut. After adjustments are made, tighten the bottom nut while holding the upper nut in place. Torque bottom nut to a minimum of 20 ft-lb.



Adjust Door Closing Torque

SERIAL PLATE LOCATION

The serial plate is located at the interior left side of the merchandiser's cabinet. It contains all pertinent information such as model, serial number, amperage rating, refrigerant type and charge.

REFRIGERATION UNIT ACCESS

The merchandiser's front grille has two screws, which must be removed from either end at the top of the panel. The lower front panel may be removed by lifting the panel straight upward and over the tabs on which it is hanging. The panel is installed by reversing the above procedure. Ensure lower front panel is connected to the bottom brackets to prevent interference with door and to avoid air circulation problems.



Remove Access Panel

SHELF INSTALLATION

After the cabinet is leveled, the shelves may be installed. Wire shelves are adjustable. Shelf spacing can be adjusted by positioning the shelf clips according to individual loading requirements.

BCH-8S merchandisers have three movable wire shelves and one solid shelf. BCH-18, BCH-45 and BCH-68 merchandisers have four movable wire shelves and one solid shelf, per door. Additional shelves may be ordered as optional items.

NOTE: The movable wire shelves may be reversed so that the wire shelf lip is positioned in the front as a product stop.

NEVER BLOCK THE SOLID SHELF FRONT OPENINGS! THIS SPACE MUST REMAIN FREE OF PRODUCT FOR AIR CIRCULATION. BLOCKING THESE OPENINGS WILL ADVERSELY AFFECT PRODUCT TEMPERATURE.

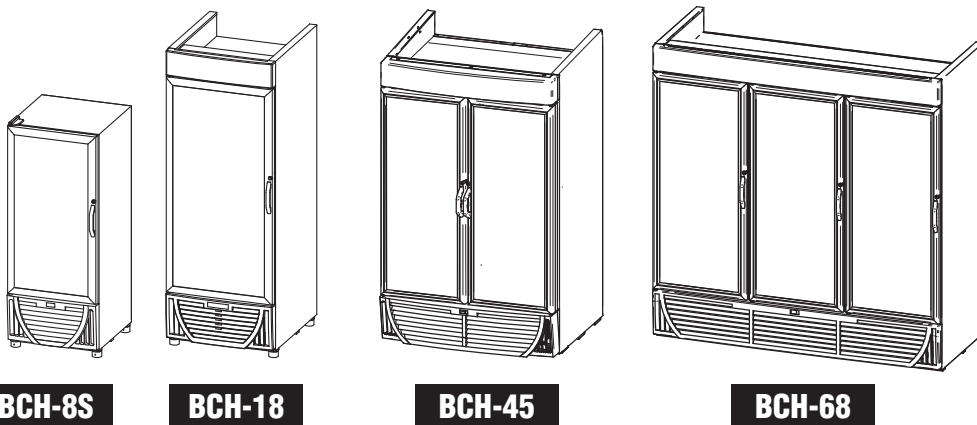
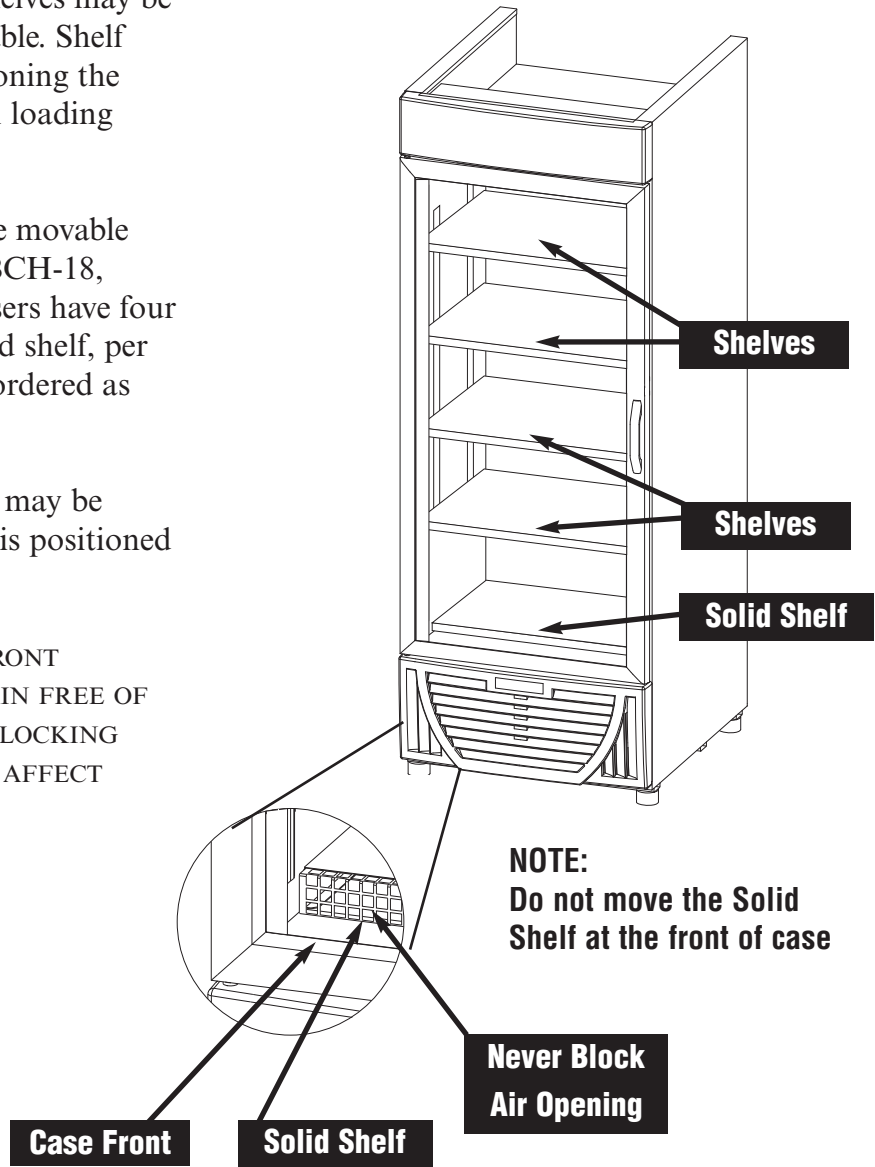

LAMPS

The merchandiser's lights are illuminated when the merchandiser's plug is plugged into a powered receptacle. The merchandiser doesn't have a light switch.

Fluorescent bulbs are standard and LEDs are optional. The LED light fixture mounts the same way and is replaced in the same manner as a fluorescent fixture.

LED fixtures power supplies are 24 VDC, and are powered from one side only. See markings on the LED fixture for proper installation instruction.

DOOR SWITCH

The merchandiser's door switch controls the evaporator fan motor. The switch shuts the evaporator fan off when the door is opened. This reduces energy consumption and helps prevent product temperatures from increasing from the door being opened and closed.

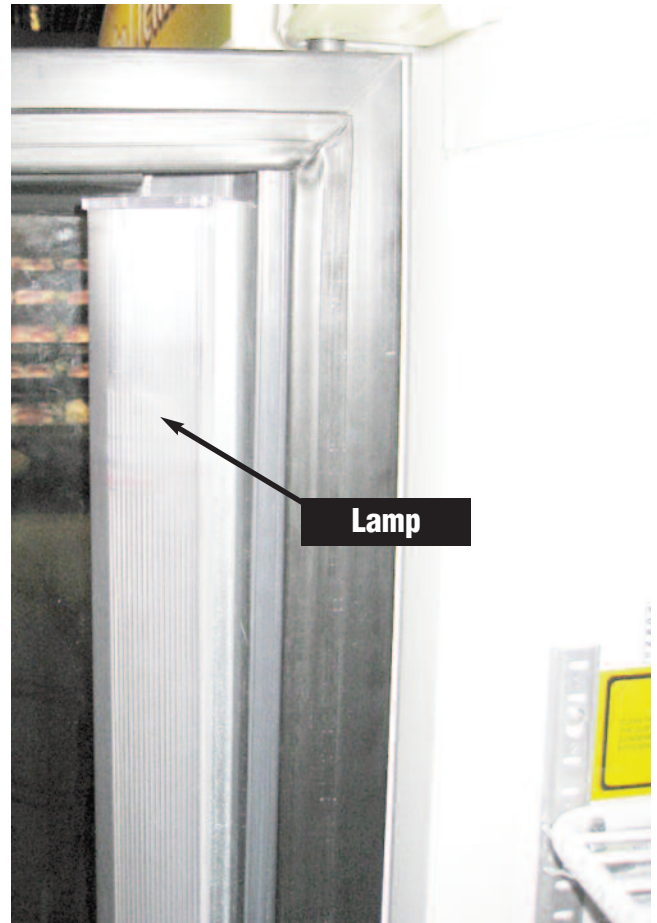

BCH Lamp



STOCKING

Product should NOT be placed in case until merchandiser is at proper operating temperature.

BCH merchandisers must remain in operation for at least 24 hours before product may be loaded into case.

Proper rotation of product during stocking is necessary to prevent product loss. Always bring the oldest product to the front and set the newest to the back.

AIR DISCHARGE AND RETURN GRILLE MUST REMAIN OPEN AND FREE OF OBSTRUCTION AT ALL TIMES.

Do not allow product, packages, signs, etc. to block air discharge or return grille. Do not use non-approved shelving, baskets, display racks, or any accessory that could hamper air curtain performance.

DO NOT STOCK PRODUCT IN THE TOP FOUR INCHES OF BCH MERCHANDISERS BECAUSE PRODUCT WILL BLOCK THE COLD AIR FLOW.

LOAD LIMITS

Product must be within designated load limit to ensure proper refrigeration and air curtain performance.

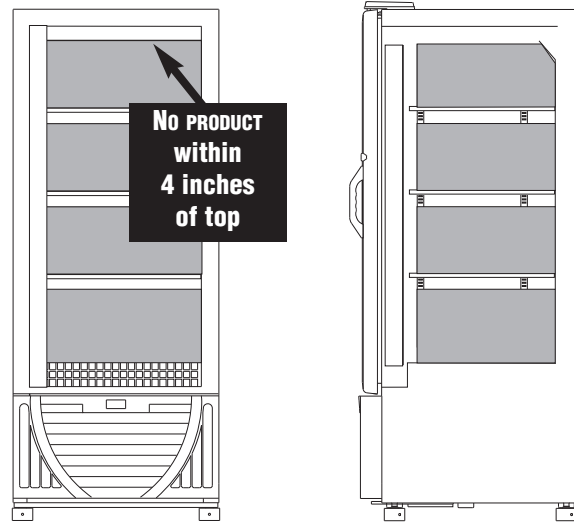

Load Limit for BCH-8S Merchandisers

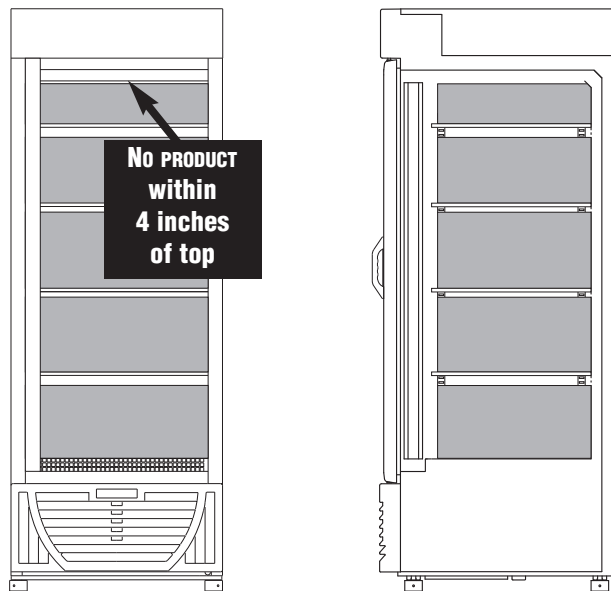

Load Limit for BCH-18, BCH-45 and BCH-68 Merchandisers

At no time should product be stocked:

- **Beyond the front of shelves**
- **Near the air discharge duct located at the top rear of case**
- **Near or covering the front return air grille**
- **Within four inches of the top of the cabinet (This space must be free of product and other materials.)**

DO NOT LOAD CASE WITH WARM PRODUCT.

ELECTRICAL / REFRIGERATION



WARNING

**Merchandiser must be grounded.
Do not remove the power supply cord ground.**

PLUG

The plug cord is 7 ft long and is located on the right hand rear of the merchandiser. Disconnect power before servicing. BCH merchandisers require a dedicated electrical circuit with ground. 12AWG is the minimum sized acceptable wire.

Fluorescent:

- BCH-8S and BCH-18 require a dedicated 15 AMP/115V circuit with grounded wall receptacle (NEMA L5-15P).
- BCH-45 and BCH-68 require a dedicated 20 AMP/115V circuit with a grounded wall receptacle (NEMA 5-20R).

LEDs:

- BCH-8S and BCH-18 require a dedicated 15 AMP/115V circuit with grounded wall receptacle (NEMA L5-15P).
- BCH-45 and BCH-68 require a dedicated 20 AMP/115V circuit with a grounded wall receptacle (NEMA L5-20P).



WARNING

— LOCK OUT / TAG OUT —

To avoid serious injury or death from electrical shock, always disconnect the electrical power at the main disconnect when servicing or replacing any electrical component. This includes, but is not limited to, such items as doors, lights, fans, heaters, and thermostats.

- Always use a dedicated circuit with the amperage stated on the unit.
- Plug into an outlet designed for the plug.
- Do not overload the circuit
- Do not use long or thin extension cords. Never use adapters.
- If in doubt, call an electrician.

If the power supply oscillates beyond the range given in the following table, a voltage regulator is required.

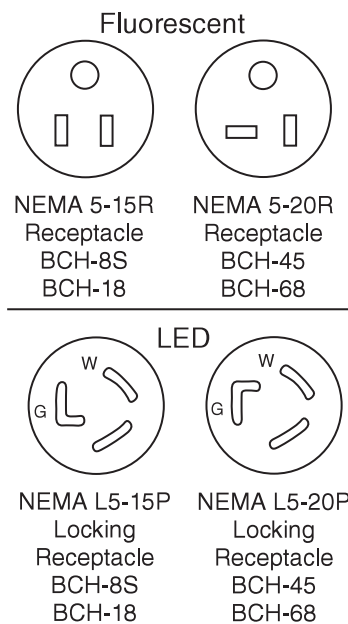

ALWAYS CHECK THE SERIAL PLATE FOR COMPONENT AMPERES

Nominal Voltage	Minimum Voltage	Maximum Voltage
120	108	132



CAUTION

Risk of Electric Shock. If cord or plug becomes damaged, replace only with a cord and plug of the same type.

REFRIGERATION

BCH merchandisers are equipped with a hermetic compressor. The condenser is of fin and tube construction. The air is taken into the merchandiser from the front of the cabinet and is also discharged from the front. See page 1-2 for details.

BCH models use R-134A refrigerant. The systems employ capillary tubes for refrigerant flow. The capillary tube is soldered to the suction line pull-out coil for proper heat exchange. If the capillary tube should become plugged or damaged, it is better to replace the heat exchanger (capillary tube and suction line).

TEMPERATURE CONTROL

The temperature control is located inside of this all-in-one cassette refrigeration unit. Merchandisers with 2 doors have two condensing units, which function differently than merchandisers with one door. The temperature control is set at the number 5 position and will maintain product temperatures in a range of 34° to 40° F.

For the BCH-8S, 18 and 45, the control is adjustable by turning the dial clockwise to change to colder temperatures. Turn the control dial counterclockwise to obtain warmer temperatures.

ELECTRONIC CONTROL (BCH-68 Only)

There is no temperature adjustment dial for the BCH-68. Instead, this merchandiser is equipped with an electronic control, which controls both cassette systems. It keeps interior temperature between 34° to 40° F.

Operating Temperatures (Coil Temperature) with Electronic Temperature Control:

**Setpoint Compressor 1:
Start 35° F (2° C) — Stop 30° F (-1° C)**

Compressor 1 startup delay is two minutes.

Compressor 2 starts 15 seconds after Compressor 1 starts.

Both compressors cycle off at the same time.

The BCH-68 electronic control is set for 2 defrosts per day, with a maximum duration of 30 minutes.

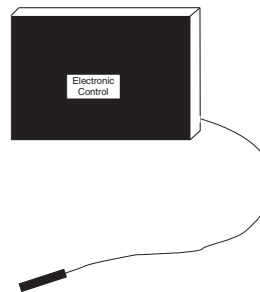

The evaporator fan motors continue to run and blow air over the evaporator coil during defrost. Air circulation increases the defrost efficiency.

CONTROLS and ADJUSTMENTS

Refrigeration Controls			Defrost Controls			
Model	Product Application	Discharge Air Temperature	Defrost Frequency (per day)	Type of Defrost	Termination Temperature	Failsafe Time (Minutes)
BCH-8S BCH-18 BCH-45	Medium Temp. (Dairy, Deli)	32° F to 34° F	Compressor Off Time	Off Time	—	—
BCH-68	Medium Temp. (Dairy, Deli)	32° F to 34° F	2	Off Time	48	30 Min.

DEFROST WATER EVAPORATION

External drain plumbing is not required. Behind the condensing unit housing cover, there is a tray for gathering and directing defrost water from the evaporator coil to the condensing unit area. The tray serves as a reservoir for storing water until the water is evaporated by a hot gas loop from the compressor.

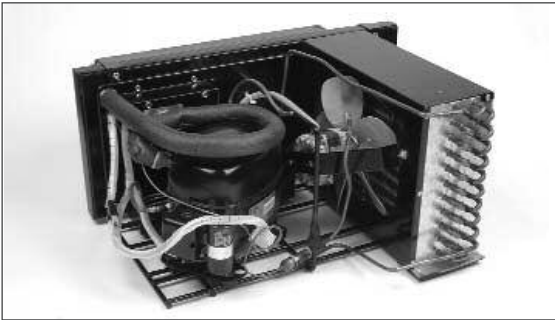

INSTALLING FDA/NSF REQUIRED THERMOMETER

The following pages provide the same information that ships with the thermometer.

This requirement does not apply to display refrigerators intended for bulk produce (refer to page 1-1).

Please note that the tape cannot be exposed after installation.

The thermometer is located at the top interior of the merchandiser's cabinet.

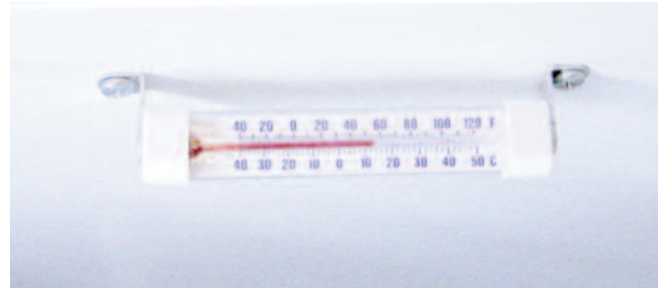

NSF Thermometer

This is an NSF-7 & US FDA Food Code Required Thermometer

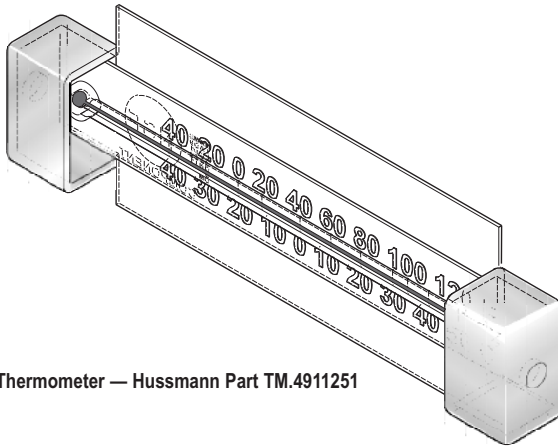

Thermometer — Hussmann Part TM.4911251

Hussmann Corporation • 12999 St. Charles Rock Road • Bridgeton, MO 63044-2483
U.S. & Canada 1-800-922-1919 • Mexico 1-800-522-1900 • www.hussmann.com
© 2007 Hussmann Corporation

Suggested Mounting Locations in Single Deck Glass Front Impact Merchandisers

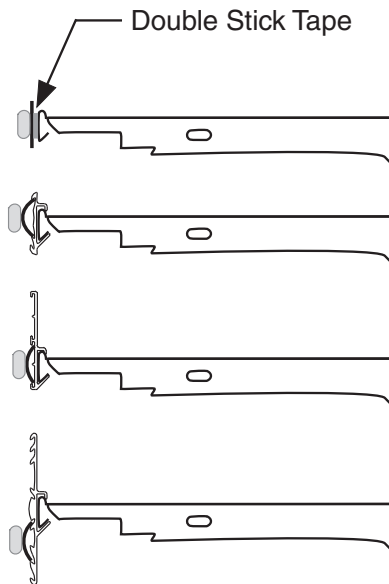
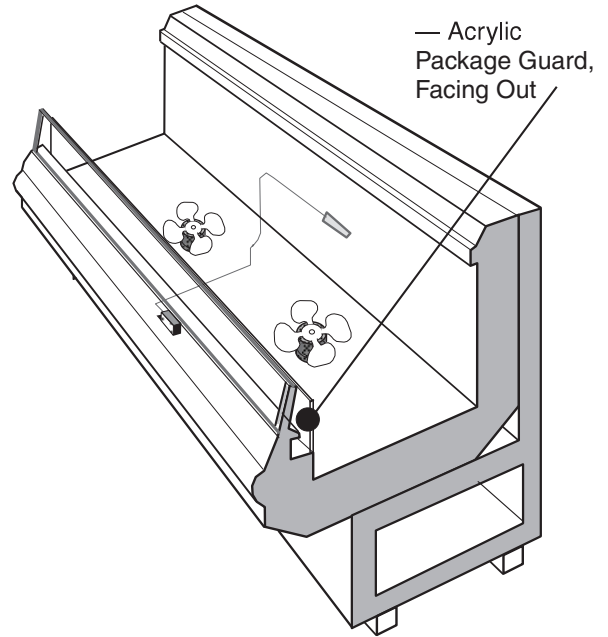

Flexible Plastic Fits in Price Tag Moldings

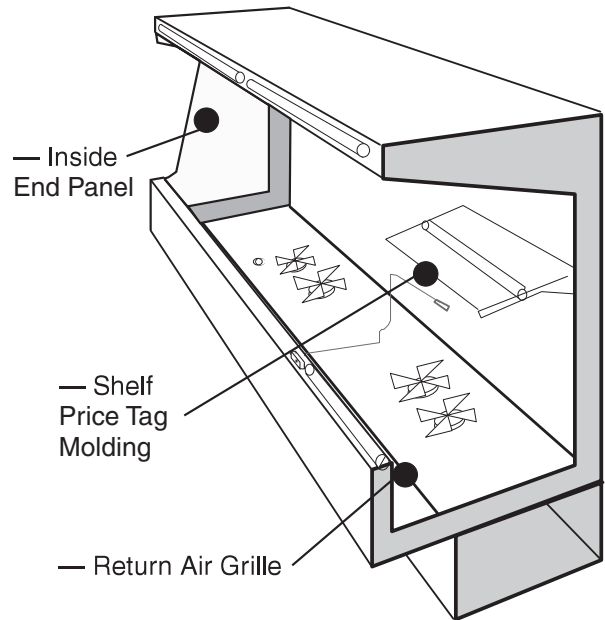

Suggested Mounting Locations in Multi-deck Merchandisers

Hussmann P/N 0429971_C

10/2007

Important – Please read!

This thermometer is provided in response to United States Food and Drug Administration (US FDA) Food Code [<http://www.fda.gov/>] and National Sanitation Foundation (NSF / ANSI) Standard 7 [<http://www.nsf.org/>]

Each installation will be different depending on how the unit is stocked, shopping patterns in the department and ambient conditions of the store. The suggested locations provided herein are possible locations. It is the responsibility of the purchaser / user to determine the location within the food storage area of the unit that best meets the code requirements above.

The thermometer may need to be moved several times to find the warmest location. Mounting options include flexible plastic for price tag molding application, magnet applied to back of flexible plastic for steel end wall, and double stick tape. Tape must not be exposed after installation.

Questions about either code should be addressed to local agencies or other appropriate officials.

**Keep with merchandiser
or give to store manager.**

DO NOT DESTROY.

MAINTENANCE

CARE AND CLEANING

Long life and satisfactory performance of any equipment is dependent upon the care it receives. To ensure long life, proper sanitation and minimum maintenance costs, these merchandisers should be thoroughly cleaned, all debris removed and the interiors washed down, weekly.

Exterior Surfaces

The exterior surfaces must be cleaned with a mild detergent and warm water to protect and maintain their attractive finish.

NEVER USE ABRASIVE CLEANERS OR SCOURING PADS. NEVER USE CAUSTIC SODA, KEROSENE, GASOLINE, THINNER, SOLVENTS, DETERGENTS, ACIDS, CHEMICALS OR ABRASIVES. DO NOT USE AMMONIA-BASED CLEANERS ON ACRYLIC PARTS.

WARNING

Do not use HOT water on COLD glass surfaces. This can cause the glass to shatter and could result in personal injury. Allow glass fronts, ends and service doors to warm before applying hot water.

WARNING

To reduce the risk of fire, electrical shock or injury when cleaning this merchandiser:

- **Unplug the merchandiser before cleaning;**
- **Keep all liquids away from electrical and electronic components;**
- **Do not use any mechanical device or other means to speed the defrost process, except as recommended by the manufacturer.**

Interior Surfaces

DO NOT USE AMMONIA-BASED PRODUCTS TO CLEAN LIGHT SHIELDS. NEVER USE ABRASIVE CLEANSERS OR SCOURING PADS.

The interior surfaces may be cleaned with most domestic detergents and sanitizing solutions with no harm to the surface.

Product must be stored in a cooler when product is removed from merchandiser for cleaning.

Do NOT Use:

- Abrasive cleansers and scouring pads, as these will mar the finish.
- Coarse paper towels on coated glass.
- Ammonia-based cleaners on acrylic parts.
- Solvent, oil or acidic based cleaners on any interior surfaces.
- Do not use high pressure water hoses.

WARNING

Product will be degraded and may spoil if allowed to sit in a non-refrigerated area.

WARNING

Do NOT allow cleaning agent or cloth to contact food product.

Do:

- Remove the product and all loose debris to avoid clogging the waste outlet.
- Store product in a refrigerated area such as a cooler. Remove only as much product as can be taken to the cooler in a timely manner.
- Disconnect electrical power before cleaning.**
- Thoroughly clean all surfaces with soap and hot water. **DO NOT USE STEAM OR HIGH WATER PRESSURE HOSES TO WASH THE INTERIOR. THESE WILL DESTROY THE MERCHANDISERS' SEALING CAUSING LEAKS AND POOR PERFORMANCE.**
- Take care to minimize direct contact between fan motors and cleaning or rinse water.
- Do NOT flood merchandiser with water.

Cleaning Shelves

Shelves and shelf clips are easily removed for cleaning the interior. Wipe down the shelves and interior with a mild detergent and replace. The bottom shelf is removable for cleaning. Lift bottom shelf up and pull out. Pay attention to the two metal tabs on the rear of the shelf. Clean case interior, and replace shelf. Metal tabs must fit in the original position.

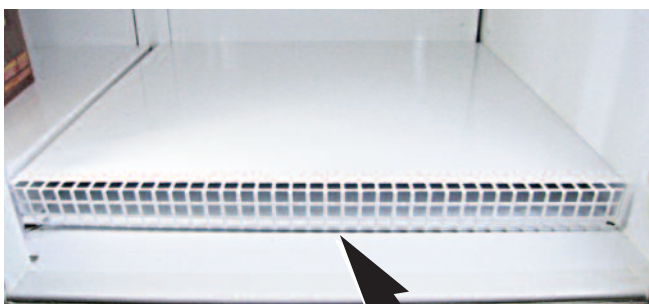

Remove Bottom Shelf

Cleaning Coils

To maintain peak operating efficiency, the coil should be cleaned at least once each month. A dirty coil slows product cooling significantly and increases energy consumption by as much as 20%. Dirt buildup on coils can also cause the compressor to lock up damaging the condensing unit.

- Remove screws on top of each side of the louvered grille, then lift off the grille.



Remove Access Panel

- Next, detach the merchandiser's electrical wire harness located on the right or left hand side near the coil.

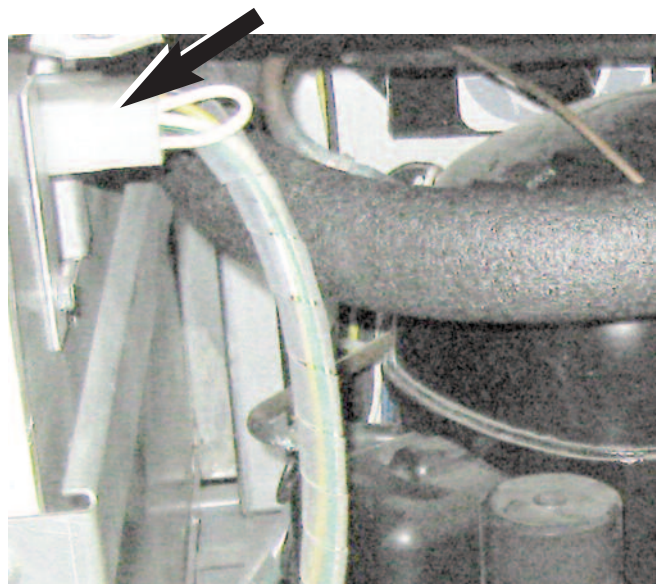

Unplug Power Harness

Remove the two screws securing refrigeration unit cassette in place.

Use the center black bar to pull the refrigeration unit's cassette forward to access the coils.

USE ONLY THE CENTER BAR TO PULL OUT THE CASSETTE. PULLING ON REFRIGERATION LINES OR OTHER PARTS WILL CAUSE DAMAGE TO THE REFRIGERATION UNIT.



Use a soft hand brush attachment on a vacuum to remove accumulated dust and debris.

Consult an authorized service technician if more extensive cleaning is needed. If the refrigeration unit is damaged, it can be replaced with a new cassette.



Cleaning the Wash Out Drain

The wash out drain is located behind the refrigeration cassette and can be cleaned with water and wiped with a soft cloth. Ensure drain is unobstructed before replacing cassette.

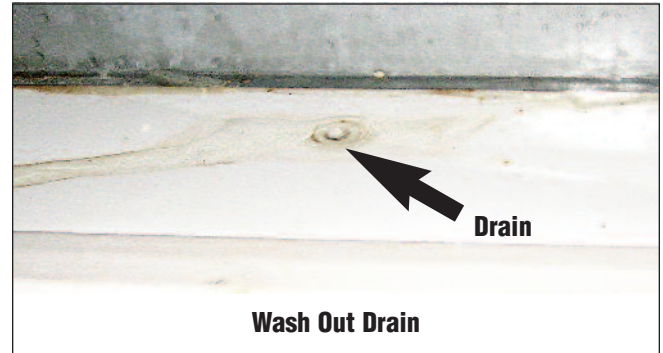

The washout drain flows into an auxiliary waste line. Next, remove the auxiliary waste line cap to drain any excess water. Place a dry towel over the line to absorb water.

Replace cap, cables and cassette.

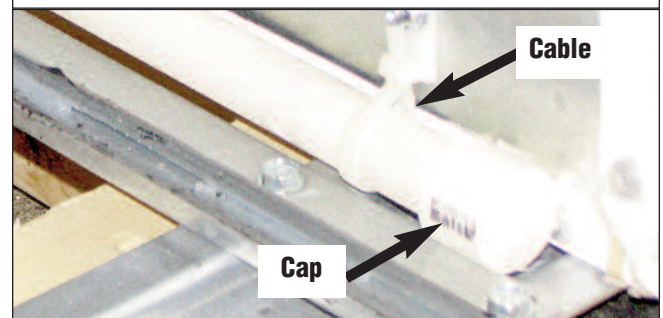

Replace Cap, Cables and Cassette

TIPS AND TROUBLESHOOTING

There are a few simple things to check before calling for service:

1. Product not cold? Refrigeration unit requires 24 hours at initial startup to cool down to operating temperature with **NO PRODUCT LOADED** in merchandiser. Ask when merchandiser was stocked, and what the usage has been.
2. Check the door and door seal for air leaks.
3. Power Supply:
Is the unit plugged in?

Is there power to the unit?
4. Location:
What are the ambient conditions— temperature and humidity, direct sun, nearby source of heat, such as oven or grill?

Is the unit level?

Has the unit been moved recently?
5. Shelves and Stocking:
Are the standard shelves in the correct places?

Is the product stocked properly?

Is the bottom shelf at the proper location?

Is air circulating properly through air openings?



**IMPORTANT
INFORMATION**

For prompt service when contacting the factory, be sure to have the case model and serial number from the case serial plate.



WARNING

— LOCK OUT / TAG OUT —

To avoid serious injury or death from electrical shock, always disconnect the electrical power at the main disconnect when servicing or replacing any electrical component. This includes, but is not limited to, such items as doors, lights, fans, heaters, and thermostats.



CAUTION

DO NOT FLOOD!

Use only enough water necessary to clean surface. Water must not drip down the case!

Never use ammonia based cleansers, abrasive cleansers, or scouring pads.

SERVICE

⚠ WARNING

— LOCK OUT / TAG OUT —

To avoid serious injury or death from electrical shock, always disconnect the electrical power at the main disconnect when servicing or replacing any electrical component. This includes, but is not limited to, such items as doors, lights, fans, heaters, and thermostats.

REPLACING INTERIOR LAMPS

BCH merchandisers have interior case lamps located on the inside of the door.

The lamps are protected by a clear, plastic diffuser. The plastic shield must be removed to replace the lamp or LED fixture.

REPLACING FLUORESCENT LAMPS

Fluorescent lamps have a plastic shield. When the lamp is replaced, keep the lamp shield to install over the new lamp.

REPLACING DISPLAY LAMP

Disconnect power to the merchandiser. Remove plastic pins attaching the display lamp cover. There are pins at the bottom of the display cover and on top of the display cover.

Remove the merchandiser's display cover panel and change out the lamp. Replace the display panel cover.

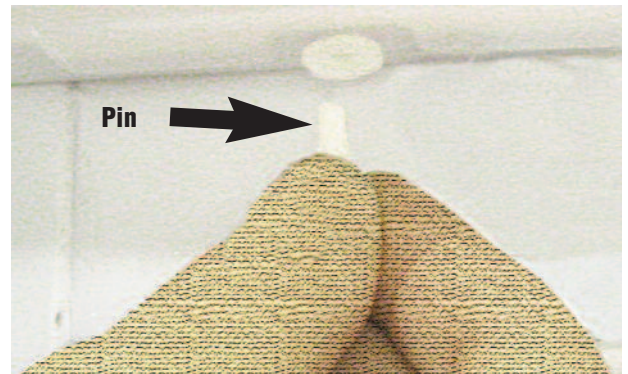

Remove Plastic Pins Attaching Display Lamp

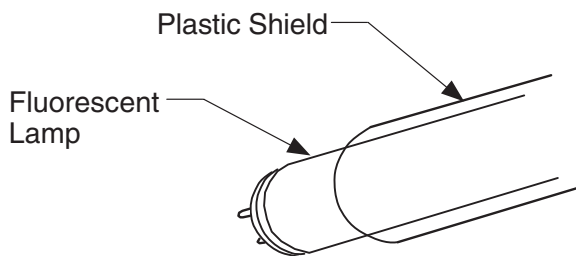

Remove Plastic Pins Attaching Display Lamp

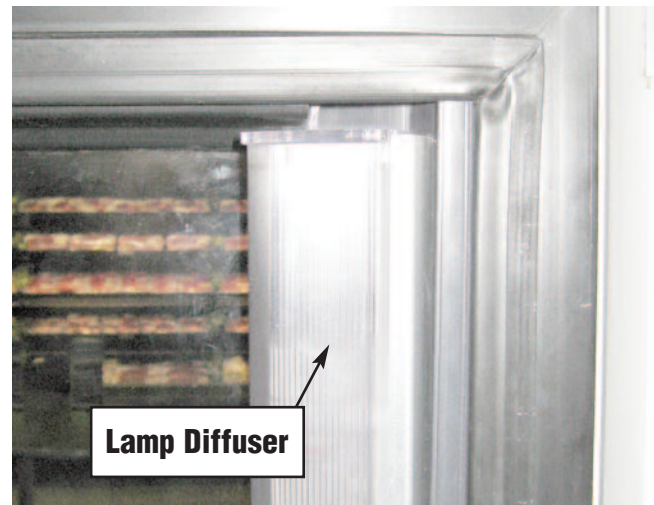

4-2 Service

To replace the lamp, do the following:

Turn OFF the electrical power to the merchandiser. Unscrew the metal clip that holds the shield in place. Grasp the plastic shield at the rear near the merchandiser's front glass as shown below.

Carefully loosen the shield from the side of the merchandiser. Once the shield is out of the rear track, the lamp shield can be removed. **For LEDs, ensure the new fixture's markings are installed on the same side as the LED being removed.**

Remove the lamp, and replace with a new lamp. Install lamp shield in rear track first to replace. Replace metal clips.



Replacing Lamp

This lamp has been treated to resist breakage and must be replaced with a similarly treated lamp in order to maintain compliance with NSF Standards.

NSF CODE 4.28.1

Contact **HUSSMANN** for replacement.

U.S. & Canada 1-800-922-1919 • Mexico 1-800-522-1900

REPLACING ELECTRONIC BALLASTS / POWER SUPPLIES

The electronic ballast or LED power supply for the BCH-8S is located on the refrigeration cassette. This ballast operates the interior lamp.

The electronic ballast or LED power supply for the BCH-18, BCH-45 and BCH-68 is located on the top of the merchandiser under a sheet metal enclosure. (BCH-68 shown.)

To access the ballast or LED power supply, the protective enclosure is removed by removing screws as shown below.

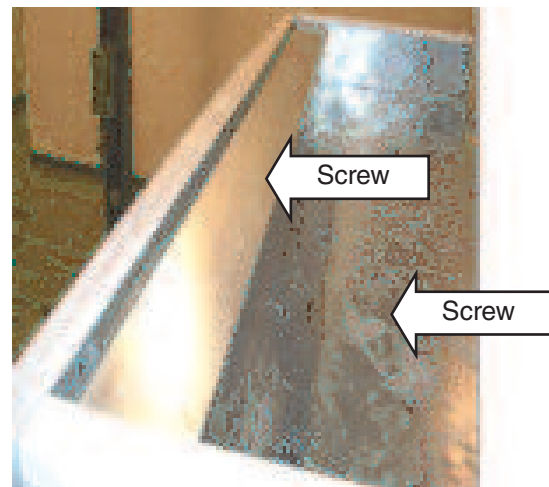

Remove Screws from Enclosure



Ballast or Power Supply Location

Item Part # Description

FAN ASSEMBLIES AND THERMOSTATS

Fan Assembly		
MO.4410536	Evaporator Fan Motor with Blade, BCH-8S, 18, 45, 68	
CT.4480804	Control, Temperature BCH-8S, 18	
CT.4482495	Control, Temperature BCH-45	
CT.4480805	Control, Temperature BCH-68	
EP.4480819	Power Cord - 15 Amp. 115 V BCH-8S, 18	
EP.4480820	Power Cord - 20 Amp. 115 V BCH-45, 68	
EP.4441816	LED Power Cord - 15 Amp. 115 V BCH-8S, 18	
EP.4480820	LED Power Cord - 15 Amp. 115 V BCH-45	
EP.4441817	LED Power Cord - 20 Amp. 115 V BCH-68	

REFRIGERATION

BCH-8S

EQ.4671514	Complete Cassette Refrigeration System	
CU.4200129	Compressor	
EQ.4611297	Condenser	
MO.4410535	Condenser Fan Motor	
FB.4780598	Condenser Fan Blade	

Item Part # Description

EV.4670597	Evaporator	
RC.4671515	Capillary Tube Assembly	
FI.4611347	Filter Drier	
EQ.4671514	Cassette Magnetic Seal	
GA.4300107	Cabinet- Air Pressurized Magnetic Seal	

BCH-18

EQ.4671341	Complete Cassette Refrigeration System	
CU.4200522	Compressor	
EQ.4611299	Condenser	
MO.4410685	Condenser Fan Motor	
FB.4780596	Condenser Fan Blade	
EV.4670598	Evaporator	
RC.4670604	Capillary Tube Assembly	
FI.4611302	Filter Drier	
GA.4981173	Cassette Magnetic Seal	
GA.4981174	Cabinet- Air Pressurized Magnetic Seal	

Item	Part #	Description	Item	Part #	Description
BCH-45/68			BU.4441800		LED Light E1N5K-4100K-C3-S4
	EQ.4671431	Right Side Complete Cassette Refrigeration System	BU.4441801		LED Light E1N5K-4100K-C3-S3
	EQ.4671431	Left Side Complete Cassette Refrigeration System	SW.4440517		Switch, Door (Fans) BCH-18/45/68
	CU.4200522	Compressor	N/A		Back Light Cover — Fascia BCH-8S
	EQ.4611299	Condenser — Right Side	MM.4911335		Back Light Cover — Fascia BCH-18
	EQ.4611300	Condenser — Left Side	MM.4911336		Back Light Cover — Fascia BCH-45
	MO.4410685	Condenser Fan Motor	TP.4995467		Back Light Cover — Fascia BCH-68
	FB.4780596	Condenser Fan Blade	DOORS		
	EV.4670595	Evaporator — Right Side	FB.4780596		Door Handle BCH 18/45/68
	EQ.4611300	Evaporator — Left Side	DO.4979896		Door Assembly, BCH-8S
	RC.4671516	Capillary Tube Assembly	DO.4995854		Door Assembly, BCH-18
	FI.4611302	Filter Drier	DO.4996015		Door Assembly, Right Side BCH-45
	GA.4981178	Cassette Magnetic Seal	DO.4995468		Door Assembly, Left Side BCH-45
	GA.4981177	Cabinet- Air Pressurized Magnetic Seal	DO.4995468		Door Assembly, BCH-68
	TM.4914521	Pencil Thermometer	HH.4916760		Torsion Rod BCH-8S
LAMPS AND BALLASTS			TP.4914406		Torsion Rod, BCH 18/45/68
	BA.4480797	Ballast, Lamp BCH-8S	GA.4996132		Door Gasket, BCH-8S
	BA.4482582	Ballast, Lamp BCH-18	GA.4996131		Door Gasket, BCH-18
	BA.4480798	Ballast, Lamp BCH-45	GA.4995871		Door Gasket, BCH-45, 68
	BA.4482582	Ballast, Lamp BCH-68	BU.4911328		Door Light Cover, 8S
	Fluorescent Lamps: Replace with Like Fixtures		BU.4911329		Door Light Cover, 18, 45, 68
	EP.4481668	LED Drive 100W-24VDC			
	BU.4441810	LED Light E1N5K-4100K-C3-S2			

				Dimensions (in inches)						
Model	Doors	Ref.	Cu. Ft. Cap.	Exterior				Interior (useable)		
				L	D*	D End Only	H**	L	D	H
BCH 8S	1	R-134A	10.6	24 ^{5/8}	27 ^{5/8}	23 ^{5/8}	60 ^{3/4}	20 ^{5/8}	18 ^{1/8}	40 ^{5/8}
BCH 18	1	R-134A	22.0	29 ^{3/8}	34	30	80 ^{3/4}	25 ^{3/8}	23 ^{1/2}	54
BCH 45	2	R-134A	41.0	52	34	30	80 ^{3/4}	48	27 ^{1/2}	56
BCH 68	3	R-134A	68.6	78 ^{1/4}	34	30	80 ^{3/4}	73 ^{1/4}	26 ^{13/16}	54

*Note: Depth dimension "D" includes 1-1/2" for door handle

**Note: Overall height includes 1 1/2 for leveling pods

Electrical										
Model	Unit H.P.	Voltage HZ/PH	Run Amps	Fuse Size	Power Cord	NEMA* Plug Nos.	Ship Weight	A/C Load (BTU/h)	Energy Consumption (kWh/day)	Energy Consumption for optional LEDs (kWh/day)*
BCH 8S	1/5	60/1	8.8	15-AMP	Yes	5-15R	310	1984	4.23	3.8
BCH 18	1/2	60/1	11.5	15-AMP	Yes	5-15R	535	4200	5.8	5.2
BCH 45	(2) ^{1/2}	115 V /60/1	11.7	20-AMP	Yes	5-20R	1014	8400	8.58	7.2
BCH 68	(2) ^{1/2}	115 V /60/1	13.5	20-AMP	Yes	5-20R	1036	8400	11.38	9.4

*Note: Locking plug required when LEDs are specified

Model	No. Wire Upper Display Shelves	Cans	No. Can Facings	12 oz Bottles	20 oz Bottles	No. 20 oz Bottle Facings
BCH 8S	3	392	8	224	168	7
BCH 18	4	900	10	450	415	9
BCH 45	8	1870	16	945	760	16
BCH 68	12	2760	24	1380	1115	—

REFRIGERATION DATA

Note: This data is based on store temperature and humidity that does not exceed 75°F and 55% R.H. unless otherwise stated. Schedule defrost at night while lights are off.

BCH

Thermostat Setting CI/CO (°F)

BCH-8S/45/68	39 / 23
BCH-68	35 / 30

Condensing Unit (hp)

BCH-8S	1/5
BCH-18	1/2
BCH-45 / 68	1/2 x (2)

Condensing Unit Capacity

BCH-8S	1625
BCH-18	3440
BCH-45 / 68	3440 x 2

20° F evaporator and 130° F condenser temperature

DEFROST DATA

Frequency (hr)

BCH-8S, 18, 45	Compressor Off Cycle
BCH-68	2 per day

OFFTIME

Failsafe (minutes)

BCH-68	30
--------	----

Defrost Temperature Termination

BCH-68	48° F
--------	-------

PHYSICAL DATA

Refrigerant Charge

BCH-8S	8 oz	0.226 kg
BCH-18	11 oz	0.312 kg
BCH-45	11.5 oz	0.326 kg each cassette (2)
BCH-68	12.5 oz	0.353 kg each cassette (2)

Electrical Data

Note: These are rated values for individual components and should not be added together to determine total merchandiser electrical load.

	8S	18	45	68
Number of Evaporator Fan Motors	1	2	4	4
Evaporator Fans 115V, 60Hz Standard				
Amperes	0.54	1.08	2.16	2.16
Watts	41	82	164	164
Condensing Unit (115V, 1Ph, 60Hz) Standard				
Compressor LRA	22.2	42	42 each	42 each
Compressor RLA	3.0	6.35	6.35 each	6.35 each

Product Data

Refrigerator interior volume [liters] (cu.ft)

- BCH-8S 314.31 liters /case (11.4 cu. ft /case)
- BCH-18 594.65 liters /case (24.7 cu. ft /case)
- BCH-45 1247.92 liters /case (44.7 cu. ft /case)
- BCH-68 1939.70 liters /case (68.5 cu. ft /case)

BCH-8 (LED)

ELECTRICAL SPECIFICATIONS

VOLTAGE	115V ~
FREQUENCY	60Hz
MAX. LEAKAGE CURRENT	0.5 mA
MAX. RESISTANCE	0.14Ω

WARNING

UNPLUG THE COOLER BEFORE SERVICE TO AVOID INJURIES

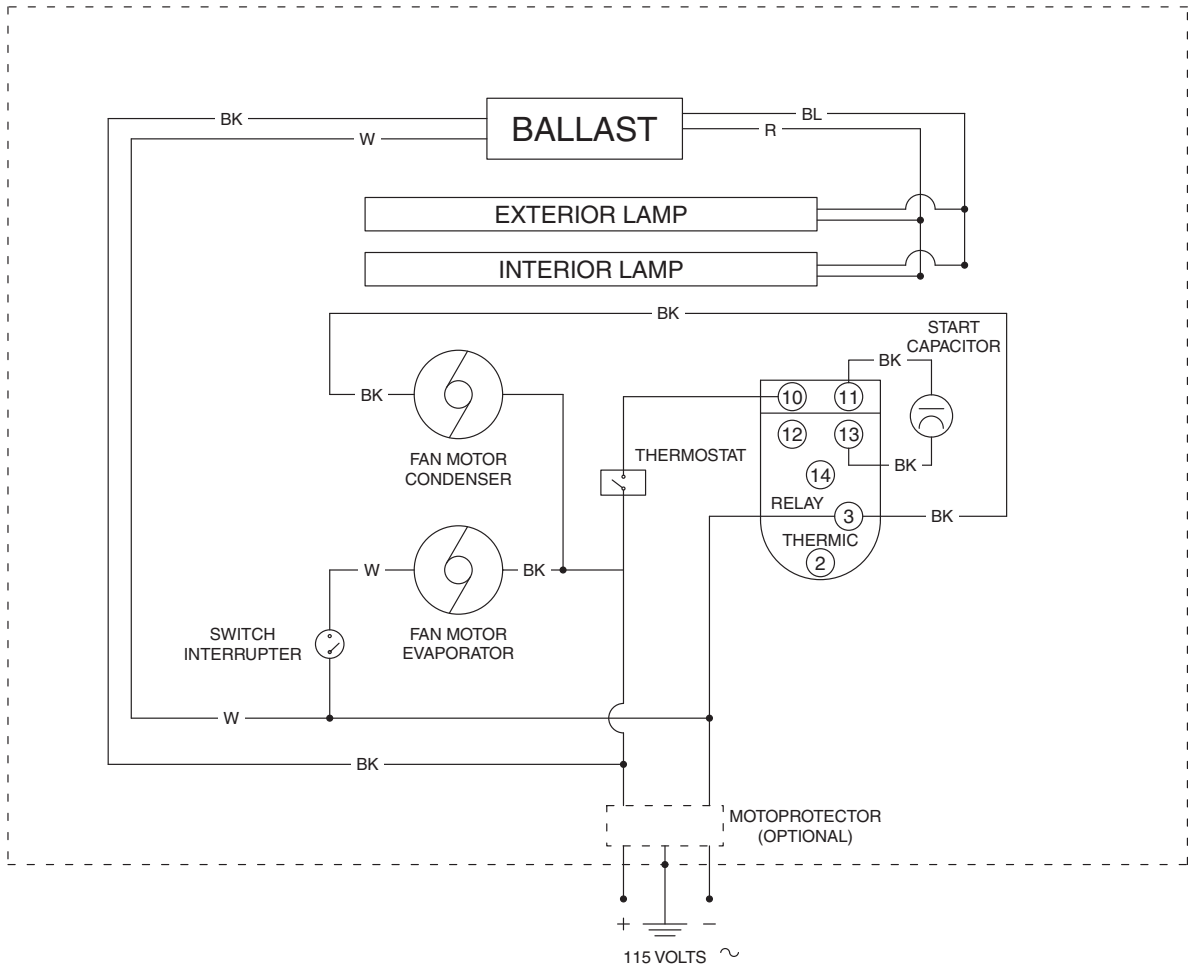

WARNING

All components must have mechanical ground, and the merchandiser must be grounded.

CIRCLED NUMBERS = PARTS LIST ITEM NUMBERS

R = Red Y = Yellow G = Green BL = Blue BK = Black W = White

● = 120V POWER ○ = 120V NEUTRAL ⊥ = FIELD GROUND  = CASE GROUND

BCH-8

ELECTRICAL SPECIFICATIONS

VOLTAGE	115V ~
FREQUENCY	60Hz
MAX. LEAKAGE CURRENT	0.5 mA
MAX. RESISTANCE	0.14Ω

WARNING

UNPLUG THE COOLER BEFORE SERVICE TO AVOID INJURIES

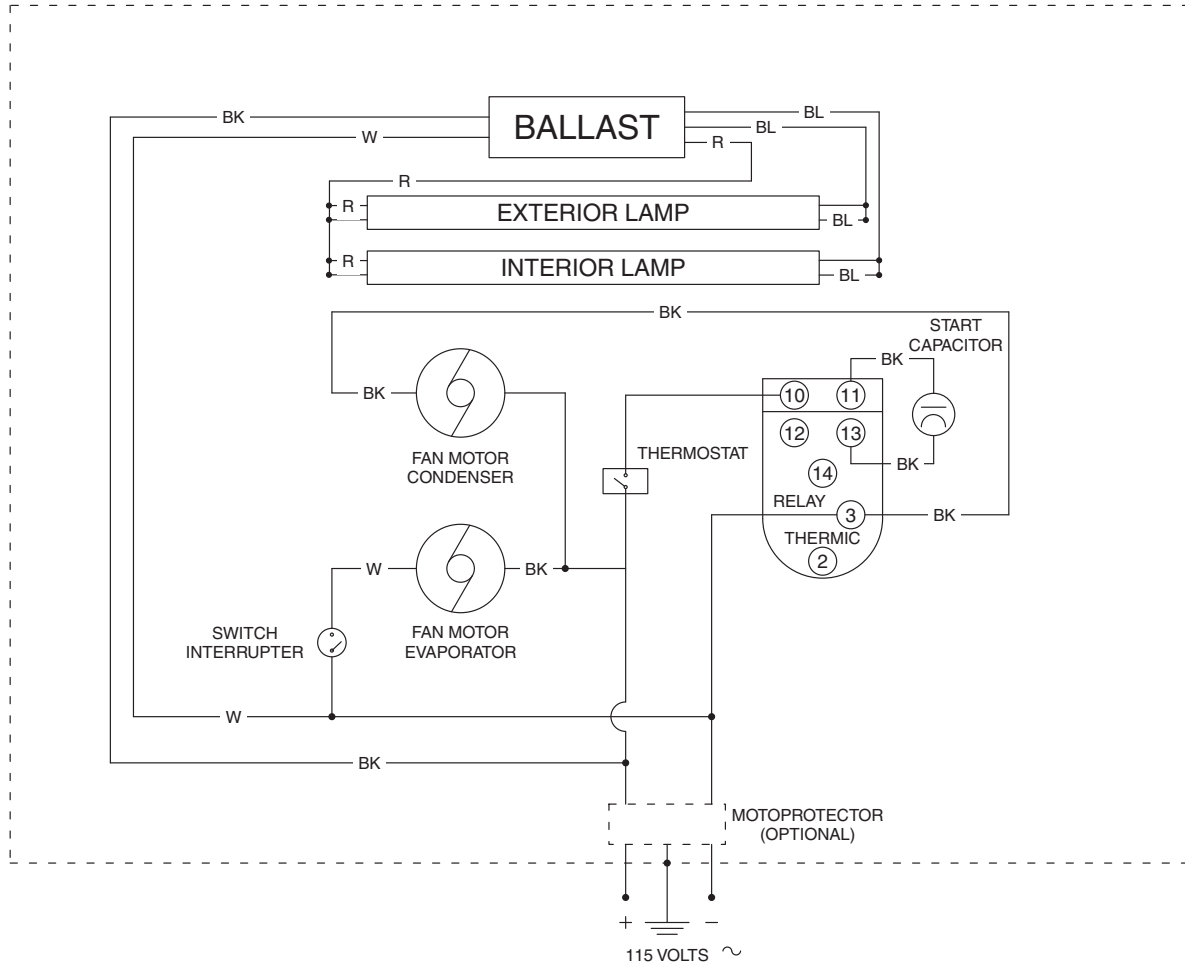

WARNING

All components must have mechanical ground, and the merchandise must be grounded.

CIRCLED NUMBERS = PARTS LIST ITEM NUMBERS

R = Red Y = Yellow G = Green BL = Blue BK = Black W = White

● = 120V POWER ○ = 120V NEUTRAL ⊥ = FIELD GROUND  = CASE GROUND

BCH-18 (LED)

ELECTRICAL SPECIFICATIONS

VOLTAGE 115V
 FREQUENCY 60Hz

WARNING

UNPLUG THE COOLER BEFORE SERVICE TO AVOID INJURIES

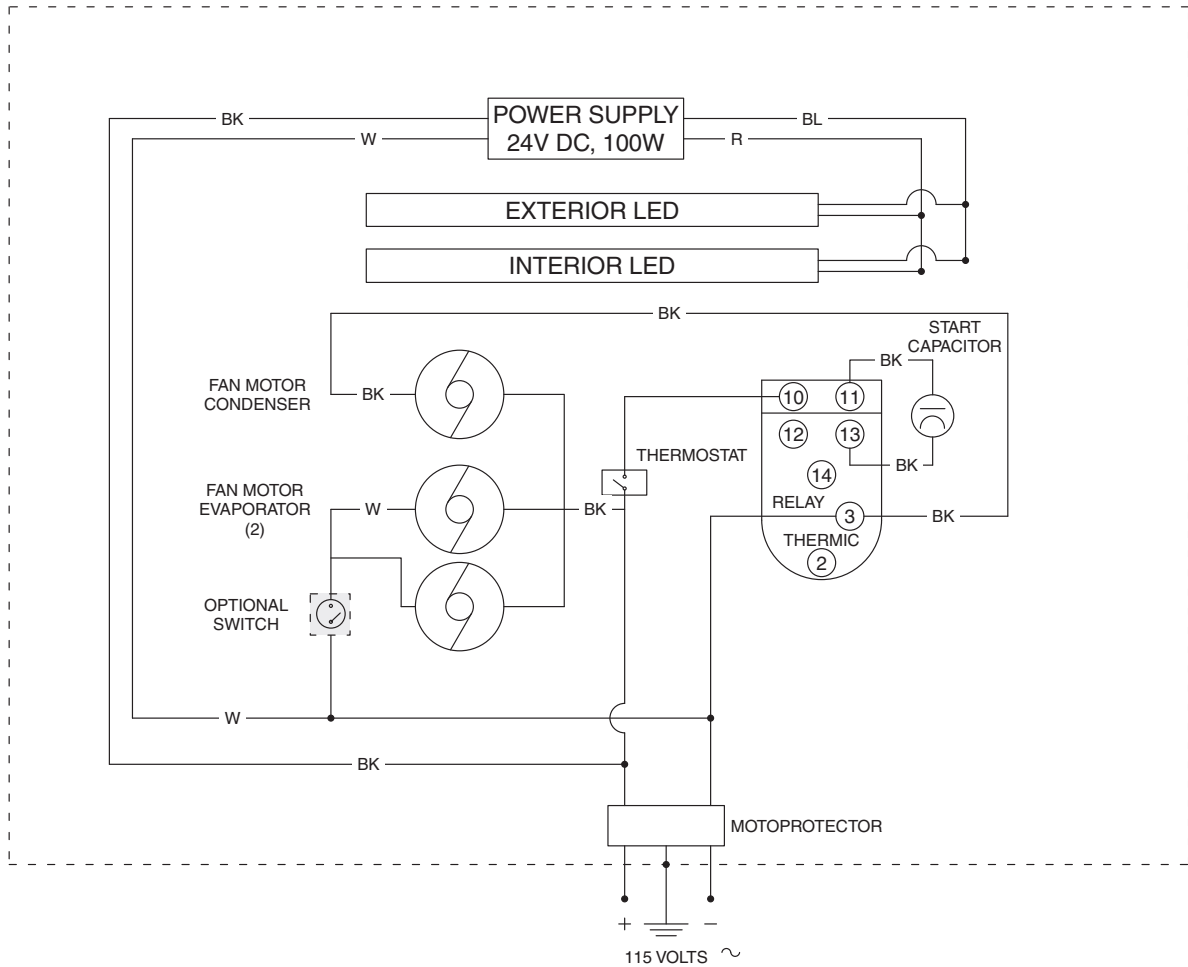

WARNING

All components must have mechanical ground, and the merchandiser must be grounded.

CIRCLED NUMBERS = PARTS LIST ITEM NUMBERS

R = Red Y = Yellow G = Green BL = Blue BK = Black W = White

● = 120V POWER ○ = 120V NEUTRAL ⊥ = FIELD GROUND ≡ = CASE GROUND

BCH-18

ELECTRICAL SPECIFICATIONS

VOLTAGE	115V ~
FREQUENCY	60Hz
MAX. LEAKAGE CURRENT	0.5 mA
MAX. RESISTANCE	0.14Ω

WARNING

UNPLUG THE COOLER BEFORE SERVICE TO AVOID INJURIES

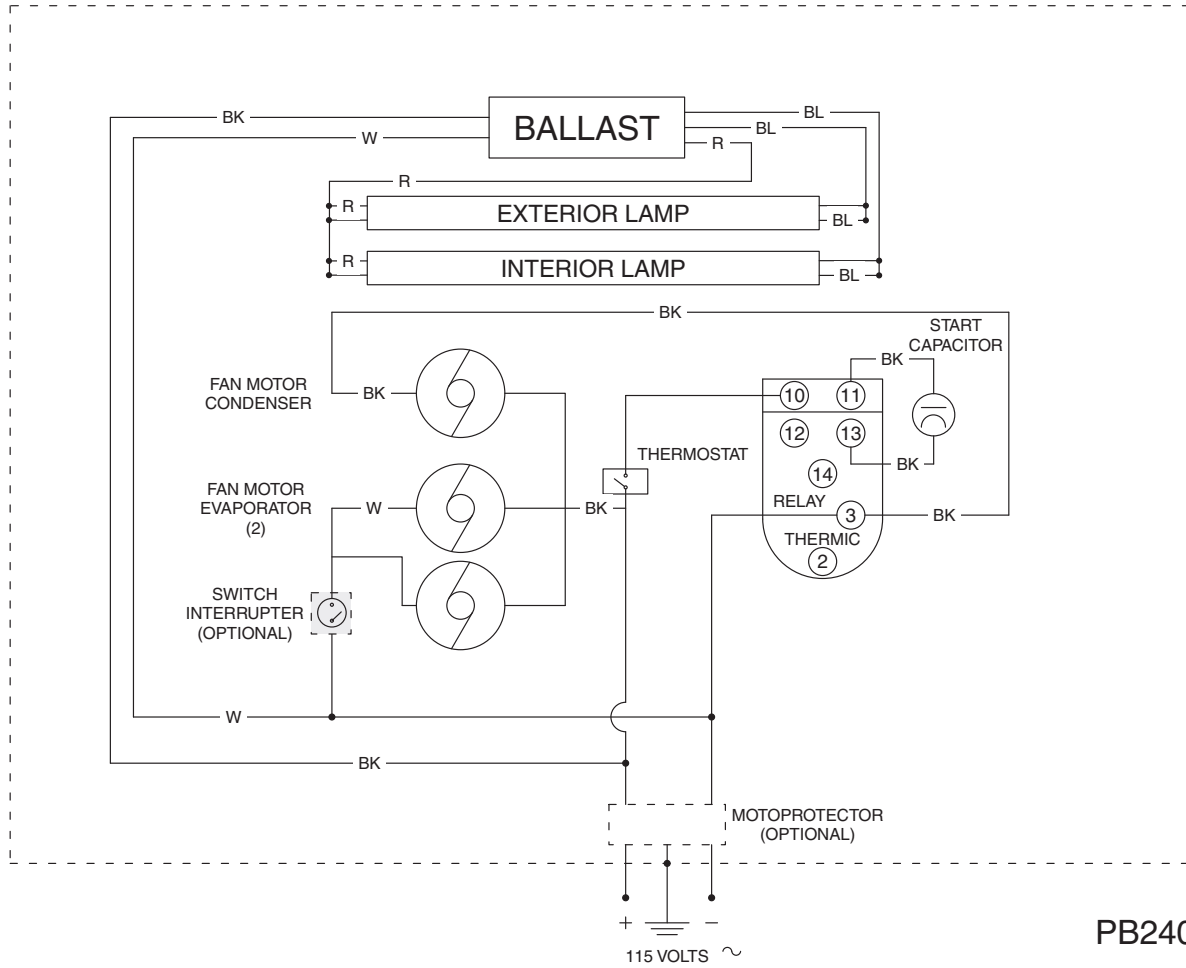

PB2402474.

WARNING

All components must have mechanical ground, and the merchandise must be grounded.

CIRCLED NUMBERS = PARTS LIST ITEM NUMBERS

R = Red Y = Yellow G = Green BL = Blue BK = Black W = White

● = 120V POWER ○ = 120V NEUTRAL ⊥ = FIELD GROUND $\overline{\overline{\overline{\quad}}}$ = CASE GROUND

BCH-45 (LED)

ELECTRICAL SPECIFICATIONS

VOLTAGE 115V ~
 FREQUENCY 60Hz
 MAX RESISTANCE 0.14Ω

WARNING

UNPLUG THE COOLER BEFORE SERVICE TO AVOID INJURIES

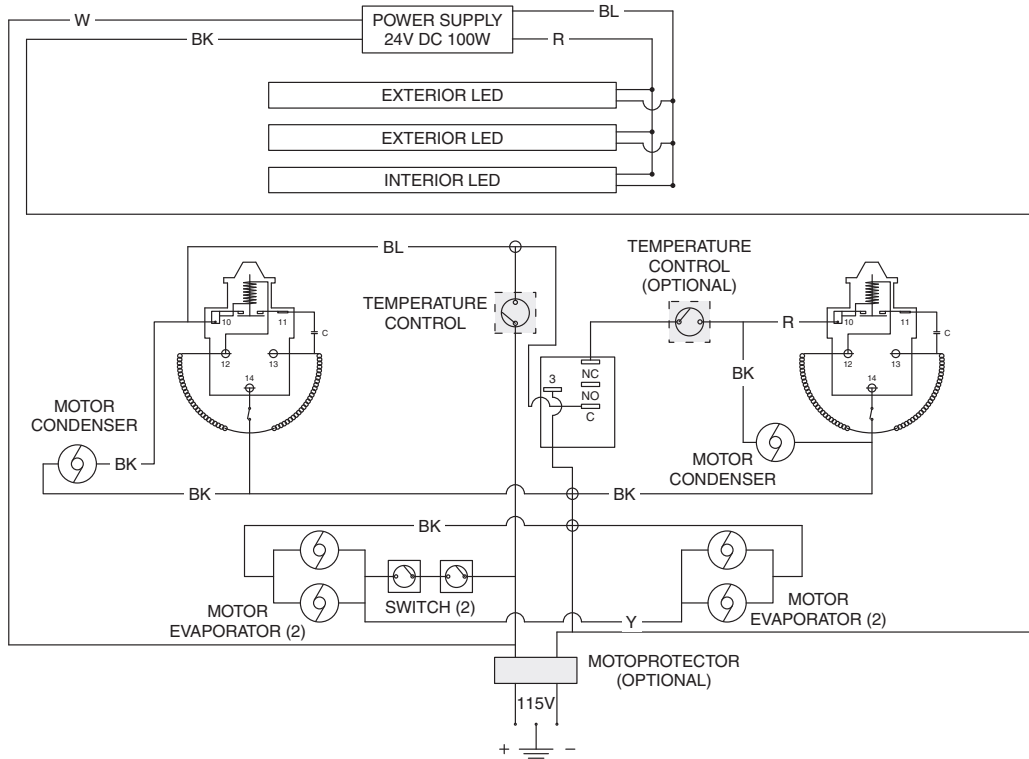

WARNING

All components must have mechanical ground, and the merchandise must be grounded.

CIRCLED NUMBERS = PARTS LIST ITEM NUMBERS

R = Red Y = Yellow G = Green BL = Blue BK = Black W = White

● = 120V POWER ○ = 120V NEUTRAL ⚡ = FIELD GROUND $\overline{\text{mm}}$ = CASE GROUND

BCH-45

ELECTRICAL SPECIFICATIONS

VOLTAGE	115V ~
FREQUENCY	60Hz
MAX LEAKAGE CURRENT	0.5 mA
MAX RESISTANCE	0.14Ω

WARNING

UNPLUG THE COOLER BEFORE SERVICE TO AVOID INJURIES

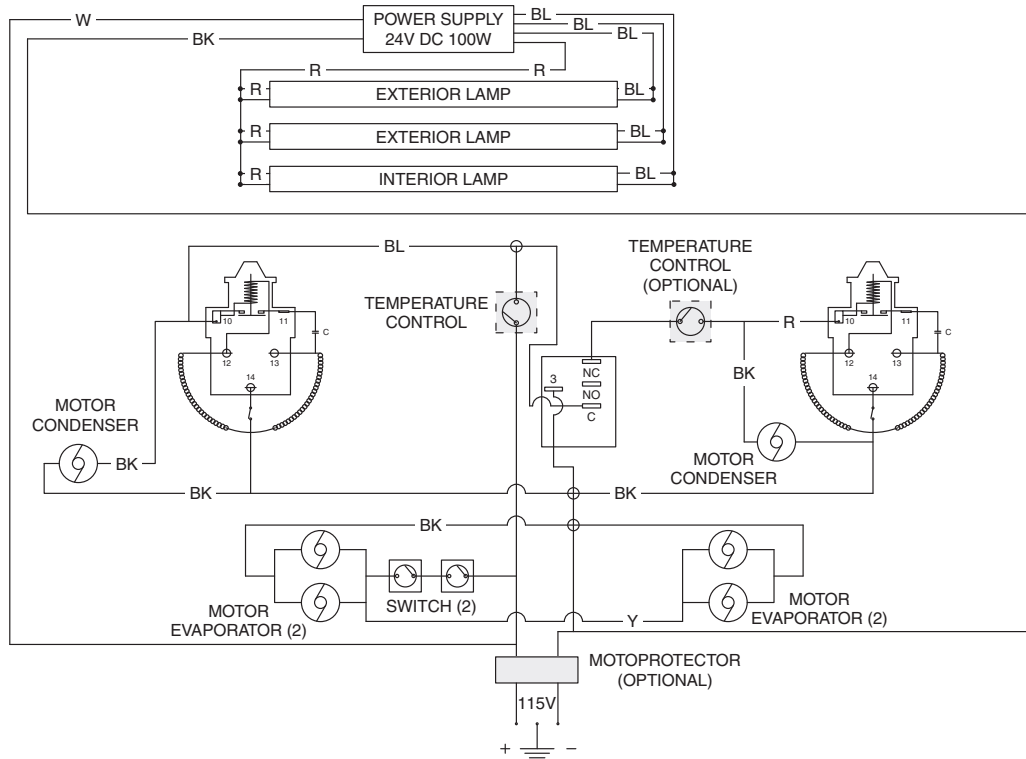

WARNING

All components must have mechanical ground, and the merchandise must be grounded.

CIRCLED NUMBERS = PARTS LIST ITEM NUMBERS

R = Red Y = Yellow G = Green BL = Blue BK = Black W = White

● = 120V POWER ○ = 120V NEUTRAL ⊥ = FIELD GROUND \overline{m} = CASE GROUND

BCH-68 (LED)

ELECTRICAL SPECIFICATIONS	
VOLTAGE	115V ~
FREQUENCY	60Hz
MAX RESISTANCE	0.14Ω

WARNING

UNPLUG THE COOLER BEFORE SERVICE TO AVOID INJURIES

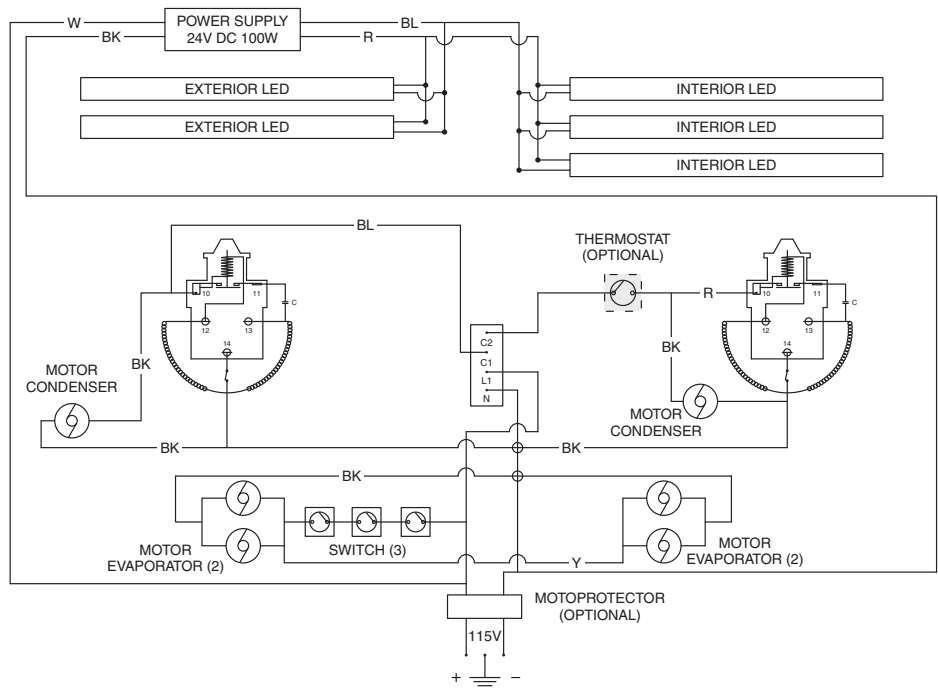

WARNING

All components must have mechanical ground, and the merchandiser must be grounded.

CIRCLED NUMBERS = PARTS LIST ITEM NUMBERS

R = Red Y = Yellow G = Green BL = Blue BK = Black W = White

● = 120V POWER ○ = 120V NEUTRAL ⚡ = FIELD GROUND ▯ = CASE GROUND



HUSSMANN[®]

**To obtain warranty information
or other support, contact your
Hussmann representative.
Please include the model and
serial number of the product.**

Hussmann Corporation, Corporate Headquarters: Bridgeton, Missouri, U.S.A. 63044-2483 01 October 2012

Husmann Corporation
12999 St. Charles Rock Road
Bridgeton, MO 63044

www.husmann.com