



**INSTALLATION, OPERATING
and
SERVICE MANUAL**

**WOOD FURNACE WFA-85
WOOD/ELECTRIC FURNACE WFA-85E**

All installations must be made in accordance with local and provincial or state codes which may differ from the manual.

**HEAD OFFICE
MARKETING / PRODUCTION
Newmac Mfg. Inc.**

DEBERT AIR INDUSTRIAL PARK,
LANCASTER CRESCENT
P.O. BOX 9, DEBERT
NOVA SCOTIA, BOM 1G0
PHONE: 902-662-3840
FAX: 902-662-2581
EMAIL: newmac@newmacfurnaces.com

**WAREHOUSE
Newmac Mfg. Inc.**

430 SPRINGBANK AVE., SOUTH
P.O. BOX 545
WOODSTOCK, ONTARIO
N4S 7Y5
PHONE: 519-539-6147
FAX: 519-539-0048
HOMEPAGE: newmacfurnaces.com



**NOTICE TO HOMEOWNER:
READ THESE INSTRUCTIONS
SAVE THESE INSTRUCTIONS**



2210xxx June 2012

DRAFT

SOLID FUEL EPA FURNACE MODEL WFA-85

General Instructions

It is the responsibility of the consignee of the furnace to examine the package for damage and, if found, to note the same on the Carrier's Bill of Lading.

Package Contents:

#1 - Heat exchanger with all panels installed, blower with motor, belt and pulleys installed, filters installed, secondary air assembly installed, and instruction booklet in blower compartment. Brick rack, draft fan c/w thermostat, 2 brick, baffles and barometric draft regulator in firebox.

#2 - 3 Boxes of 8 Full Firebrick (24 bricks)

Installation

*Check with provincial, state or local codes concerning clearances, chimney requirements and other installation procedures before installation. Some codes may vary from the requirements set forth in this manual.

Minimum Installation Clearance From Combustible Material

FROM	MINIMUM CLEARANCE
Fire door end	48"
One Side	6"
Other Side (Walkway)	24"
Blower door end	30"
Flue Pipe	18"
Plenum and Takeoff Ducts to 6' from Furnace	6"
Duct beyond 6' from Furnace	1/2"
Return air plenum and take off ducts to 6' from furnace	6"
Floor non-combustible	

Solid fuel or other combustibles must not be stored within the above clearances.

1. Install brick in firebox according to FIG. 1 and baffles according to FIG. 2. After brick is in position place 2" of sand in bottom of firebox. (Use pit sand only.) Install draft fan & thermostat according to Wiring FIG. 4.
2. Do not use a flue damper with this furnace.
3. **Caution:** If this furnace is used as a replacement for an existing furnace observe the following:
 - a. Make sure there is a minimum of 6" clearance above the warm air plenum as far as 6 feet out from the furnace. Beyond 6 feet there must be a minimum of 1/2" clearance.
 - b. Metal return air ducts must be used. (No combustible materials in return air ducts.)
 - c. Use flue pipe as per B365 Clause 5.

DRAFT

This furnace must be connected to a chimney approved for wood burning appliances, ie. CSA-B366.1-M91 (Canada) and UL 391 (US), or a masonry chimney conforming to the requirements of provincial regulations or, in the absence of such regulations, to the requirements of the National Building Code of Canada. Newmac recommends an 8" round or 8" square chimney flue (inside dimension), however, this may be reduced to a 7" providing there is enough draft at the appliance to operate as designed. It is the responsibility of the installer to ensure there is sufficient draft in all cases. Draft should be between -0.03 and -0.05 in. wc. No other appliance should be connected to this chimney flue, unless the installation conforms to clause 5 of B365.

amended May 2009

The installation must conform with the regulations of the local authorities having jurisdiction with the applicable Electrical Code, and with the regulations in C.S.A. Standard B365 "The Installation Code for Solid Fuel Burning Appliances and Equipment".

Flue pipe connections must be secured with metal screws and have as few elbows as possible. This furnace should be installed by a qualified furnace serviceman.

Caution:

The flue collar is sized so that a trade size flue pipe fits snugly inside it. Joints in flue pipes, including the connection at the appliance and the chimney, shall have at least 30 mm (1 3/16 inch) over lap. Flue pipe connections must be secured with at least 3 metal screws or an equivalent mechanical means; and be made tight in accordance with good practice.

The flue products may contain carbon monoxide particularly when the wood fire is being starved for air (made to burn at slow rate). Therefore, the flue pipe must seal tight and must not be inserted into the return air stream of the circulating blower.

Wood storage should conform to local bylaws, and should not be within minimum clearances for combustible surfaces as shown above. This furnace must be installed by a qualified furnace serviceman.

NOTE:

COMBUSTION AIR: Where fans are used in the fuel storage area, they should be installed so as not to create negative pressures in the room where the solid fuel burning appliance is located.

OUTSIDE COMBUSTION AIR: Provision for outside combustion air may be necessary to ensure that fuel-burning appliances do not discharge products of combustion into the house. Guidelines to determine the need for additional combustion air or not may not be adequate for every situation. If in doubt, it is advisable to provide additional air.

Outside combustion air may be required if:

1. the solid-fuel-fired appliance does not draw steadily, experiences smoke roll-out, burns poorly, or back-drafts whether or not there is combustion present.
2. existing fuel-fired equipment in the house, such as fireplaces or other heating appliances smell and do not operate properly, suffer smoke roll-out when operated, or back-draft whether or not there is combustion present;
3. any of the above symptoms are alleviated by opening a window slightly on a calm (windless) day;
4. the house is equipped with a well-sealed vapor barrier and tight fitting windows and/or has any powered devices which exhaust house air;
5. there is excessive condensation on windows in the winter; or
6. a ventilation system is installed in the house.

If these or other indications that infiltration air is inadequate, additional combustion air should be provided from the outdoors.

DUCT INSTALLATION: Not to be connected to ductwork that is still connected to another furnace.

As the unit may be used as a gravity furnace when the power is off, the following is recommended:

1. Locate the furnace as centrally as possible in the home so the best warm air distribution may be enjoyed.
2. Use an extended plenum (central duct) at least one size larger than called for in National Warm Air Standards.
3. Use a minimum pipe size of six inches diameter in runs and in no case smaller than five inches diameter.
4. Slope extended plenums and runs as much as possible to facilitate gravity flow of warm air.

BELT TENSION: When adjusting the proper pulley setting make certain that the belt is able to flex approximately one inch without movement of the motor pulley.

IMPORTANT: This furnace must have a MINIMUM return air duct size equal to 250 sq. in. and a MINIMUM supply air duct size equal to 180 sq. in. The supply air extended plenum should extend 8 – 10 feet out from the furnace, then gradually transitioned to the end of the duct system to provide a .20" W.C. static pressure.

HUMIDIFIER

Install the humidifier in the return air plenum. This prevents possible damage due to excessive temperatures when there is a power failure.

Metal connecting ducting from the warm air plenum is recommended rather than plastic ducting.

DRAFT

BURNING WOOD OPERATING INSTRUCTIONS

When installation is complete, close the supply switch and turn the thermostat above room temperature. Check to make sure the forced draft fan above the fire door is operating when the thermostat is set above room temperature.

The draft fan should be off when thermostat is set below room temperature.

The maximum draft is not to be more than - .05 as damage may result to the furnace when operated as a gravity unit.

The circulating air blower speed is adjusted at the factory to give an adequate temperature rise under most conditions. However, because of various temperatures that can result from burning wood, the blower speed can be adjusted by the motor pulley. Under no circumstances should the temperature rise be more than 80°F (27°C).

NOTE:

Before loading the fire box, turn the thermostat up to insure that the draft fan is on. This provides an air curtain to avoid smoke roll out during loading and fans the coals to assist the ignition process of your new fuel. It also helps to promote draft when there is inadequate draft. After the fire is established, set the thermostat to desired temperature.

To start the fire, turn up the thermostat to **Maximum** setting to turn **ON** Forced Draft Fan. Place some newspaper crumpled up in the bottom of the firebox on top of the minimum requirement of 2" of sand, ash or firebrick. Add kindling and light the fire. When the fire starts add some larger pieces of kindling or wood until you have a good fire. The idea is to ultimately end up with a good bed of ash and coals which helps to maintain a good controllable fire.

When reloading the firebox there will be a build up of ash and coals from the previous fire. Rake the coals mixed with ash to the front of the firebox which places the coals at the front. Load in your wood and the fire should light in a few minutes.

Return Thermostat in main living space to regular setting.

When the firebox gets full of ash (within two inches of door level), in the morning, before loading the firebox, push or rake the coals to the rear of the firebox. Remove the ash from the front of the firebox using only the shovel supplied for this purpose. When the ashes only are removed from the front, rake the coals from the back to the front. Load with wood and the fire will again be burning in a few minutes. The fire burns best when the ashes are 3" to 4" below the fire door level.

For safe operating procedure, refer to the "Notice" label on the furnace.

COMBUSTION AIR CONTROL

The amount of combustion air allowed to enter into the firebox can be controlled by means of the Draft Control slide on the draft fan mounting plate. Set this slide plate to the position that allows sufficient combustion air in for the type of solid fuel being burned. Normally the setting is in the center between maximum and minimum, then if additional control is needed it can be adjusted accordingly. For burning wood it will vary with size and type. **DO NOT LET THE COALS/ASHES BUILD UP ANY HIGHER THAN HALF WAY UP THE FIRE BOX LINER.** When there is a buildup of coals fully open the slide plate to reduce the coals.

POWER FAILURE

In case of prolonged power failure, remove the blower access door and air filters. The draft fan will be off, so if more combustion air is needed for the wood fire, open the slide plate. Return the slide plate to the normal position when power comes back on.

DO NOT CHARGE the fire box higher than half way up the liner as overheating may result.

FUEL

Seasoned cordwood will give the most heat. Your furnace will burn most any type of firewood. Seasoned hardwood produces more heat, and will hold a fire longer, leaving a hotter coal bed than seasoned softwood. **Coal should never be used in a heater designed for burning wood.** Never use driftwood that has been in salt water. The salt content will cause corrosion that will destroy the stainless steel in the Class A chimney, the flue connector and the firebox.

Hard wood cut to 19" maximum length, and split 4" to 10" cross section is recommended for best operating efficiency.

DRAFT

CAUTION: Burn untreated firewood only. Wood containing preservative, metal foils, coal, plastic, garbage, sulfur or oil is environmentally hazardous and will damage the appliance.

LOADING OF FUEL

Do not overfill the firebox above the firebrick. A burned-out heat chamber may result. Do not use artificial or wax logs.

Build fire on the floor of the firebox. Do not use additional grates or andirons to support the fire as these may create excessive heat.

PREPARATION AND STORAGE OF FUEL

Solid fuel should be cut and split prior to the heating season and stored in a well, aired dry place. Do not store fuel within the room heater clearances or within the space required for fuelling or ash removal. Fuel should be kept at least 5ft clear (1.5m) from the furnace. The space around the furnace should be kept free of litter and wood residue.

TYPES OF COMBUSTION AIR FOR WOOD HEATING

Unlike older airtight box heating appliances, low emission furnaces have more than one location and control for supplying combustion air into the firebox. These additional air inlets allow for near complete combustion of wood gases and particulates. Thus it is important to understand how these different air supplies work.

PRIMARY AIR starts the fire. Opening or closing this air supply then regulates how fast the furnace will burn. Primary air is supplied by the following: an adjustable slide plate to vary the burn rate and a room thermostat. Use the Primary Air Control (PAC) slide plate knob on the left side of draft fan to control the burn rate. Always start the fire with the PAC set on high and leave it on high until the secondary flames continue to burn after the PAC has been adjusted to a lower setting. Adjust the PAC accordingly when refueling. A hot coal bed requires less Primary Air to restart a fresh load of firewood.

The thermostat also controls the amount of primary air entering the unit by turning on the draft fan. Turn up the thermostat 10 to 20 minutes when reloading for a good start, then turn it down.

It is very important to keep the secondary flames burning to maximize heat output and minimize air pollution, so some experimentation will be necessary because each installation is different. Wood moisture content will also affect the amount of time that a unit will need to burn on high after each reload.

SECONDARY AIR allows the woodstove to burn clean. This preheated air enters the upper firebox just below the baffle plate. This superheated air mixed with the wood gases and flames ignites, reaching temperatures in the 1100F to 1600F range. Without Secondary Air these volatile gases would exit the stove unburned as creosote, smoke, particulates, and high levels of Carbon Monoxide, greatly decreasing efficiency. Heat comes from burning the wood gases, not the wood, which itself turns into black charcoal after the gases are all released. Secondary air increases a stoves efficiency by approximately 40% greatly reducing the amount of wood required for a heating season (up to 1/3 less wood).

SECONDARY AIR INLET (SAI) is located on the right side of the draft fan.
NEVER ATTEMPT TO BURN YOUR FURNACE WITH THE SECONDARY AIR SLIDER CLOSED OR YOUR FURNACE WILL BURN DIRTY, PRODUCE CREOSOTE AND BE LESS EFFICIENT. THE SAI MUST BE LEFT IN THE OPEN POSITION TO BURN OPTIMALLY.

WATCH YOUR CHIMNEY – If you cannot see any visible smoke coming out you are operating your stove correctly. If you can see smoke, then adjust for additional Primary Air until the smoke disappears. Remember, smoke equals lost heat!

DRAFT

LIGHTING and OPERATION

1. **IMPORTANT!** – NEVER OPERATE THIS FURNACE WITHOUT THE SECONDARY AIR TIMER IN THE LOCKED OPEN POSITION WHEN LIGHTING A FIRE OR RELOADING!
2. Set the PAC slider and the thermostat on HIGH to provide maximum draft.
3. Note that the Secondary Air Inlet is OPEN
4. Open loading door and start fire, using ample kindling to ensure rapid ignition.
5. Prime chimney if necessary by lighting dry newspaper at the very back of the firebox. A CANDLE will also work and not smoke up the room if cold air blows out the newspaper.
6. Light fire and close loading door to 1 inch.
7. Wait 5 to 10 minutes then add smaller pieces seasoned firewood. (See section concerning Fuel).
8. Set the PAC slider to maintain desired temperature in room. Medium setting is normally satisfactory. Once fire is established set the slider to the desired burn rate. This will maintain a steady temperature after the thermostat cycles.

CAUTION: Do not operate furnace with the loading door open. Continuous operation with a door open will cause severe overheating and warping. This furnace is designed for Thermostatic operation.

REFUELING

The loading door should be closed at all times except when refueling. Before opening the loading door, make sure the thermostat is turned up and the draft fan on. Allow the fire to burn rather briskly for a few minutes. Then open the loading door slowly. By allowing the fire to increase for a short period, a high draft condition has eliminated smoke in the firebox and the temperature has been raised which prevents a back or down draft.

MAINTENANCE

Failure to follow these instructions may result in poor efficiency, excessive corrosion of the heat exchanger and the possibility of a creosote fire.

DAILY: Clean out Ashes. Ashes must be put in a metal container with a lid on it before moving the ashes to the outdoors.

MONTHLY: Furnace heat exchanger and flue pipe – Ashes must be removed on a minimum of a monthly basis depending on the ash build up. The complete heat exchanger and flue pipe should be thoroughly inspected for creosote deposits, ash buildup, etc. Creosote or ash deposits must be removed by scraping and/or brushing the deposits from the heat exchanger surfaces (the baffle may have to be removed, see FIG. 2). An industrial vacuum cleaner may be used to assist in the removal of such deposits. A complete cleaning must be done immediately at the end of each heating season. If this is not done, condensation from the summer months, or any other source, will mix with the ash or creosote and cause corrosion of the heat exchanger. Corrosion is not covered under warranty.

NOTE: Establish a routine for the storage of firewood, care of the appliance, and firing techniques. Check daily for creosote buildup until experience shows how often cleaning is necessary. Be aware that the hotter the fire, the less creosote is deposited and weekly cleaning may be necessary in mild weather even though monthly cleaning may be enough in the coldest months. Have a clearly understood plan to handle a chimney fire.

CHIMNEY: Chemical chimney cleaners are not recommended as they could damage the furnace heat exchanger and flue pipe. One of the most efficient methods to clean a chimney is to lower a stiff brush (chimney brush) tied to a heavy weight down the chimney on a rope. Work the brush up and down the chimney to scrape the accumulated creosote and soot off the chimney walls. Remove the residue from the cleanout at the base of the chimney.

ANNUALLY: In the spring, after the furnace is shut down for the summer, clean the heat exchanger of all soot, ash and creosote accumulation, remove all ashes, clean the flue pipe and clean the chimney. **KEEP THE FIREDOOR OPEN APPROXIMATELY 2" TO INSURE MOISTURE REMOVAL DURING SUMMER.**

DRAFT

NOTICE

IMPORTANT:

- This furnace is tested to CSA B366.1.
- This furnace must be installed according to CSA Standard B365 "Installation Code for Solid-Fuel Burning Appliances and Equipment".
- The solid fuel side of this furnace is designed to burn wood only.
- Proper flue draft must be maintained to allow combustion gases to flow freely out the chimney.
- ONLY ULC S629-650 C or masonry chimney is acceptable.

FOR SAFE OPERATION:

- Load fuel carefully or damage may result.
- Do not load solid fuel higher than the fire box liner.
- Do not use chemical or fluid fire starters.
- Do not attempt to light a fire when there is oil vapour present.
- Minimum flue draft - .03" W.C.
- Maximum flue draft - .05" W.C.
- Do not burn garbage, manufactured fire logs, gasoline, naphtha or crankcase oil.
- Keep the furnace doors tightly closed except for refueling and cleaning.
- Maintain all door seals in good condition.
- To maintain furnace efficiency and prevent soot fires, clean the heat exchanger, flue pipes, and chimney at the end of each heating season and as frequently as required during the heating season to prevent soot accumulation. The furnace and flue must be in good condition. Turn off power to the furnace when cleaning the furnace and flue.
- Do not store fuel or combustible material within the furnace clearances.
- Do not use salt wood (driftwood gathered from the seashore).
- Return air ducts are to be "metal" not "wooden".

TO PREVENT DAMAGE:

- Do not set the flue draft above - .05" W.C. as the fire could burn out of control.
- Do not open the furnace door slide plate damper during normal operation.
- Furnace requires a minimum of 2" of sand or wood ash in bottom of firebox.

SPECIAL PROCEDURES

POWER FAILURE:

1. Remove the blower access door and air filters for better air circulation. If the furnace is in an enclosed area (furnace room) open the door to the room.
2. If equipped, to control the fire open the slide plate damper in the furnace door. THIS DAMPER SHOULD BE CLOSED FOR NORMAL OPERATION.
3. Do not load the firebox higher than half way up the fire box liner.

SOOT FIRE

Close all sources of air that can reach the fire through the furnace and draft regulator. Insure the draft fan above the fire door is turned off. Do not attempt to take the flue pipes down until the fire has been completely extinguished.

RUNAWAY FIRE

This can be caused by too high a flue draft or excessive fueling.

1. Close all sources of air to the furnace. Insure draft fan is turned off.
2. Set the barometric draft regulator wide open to reduce draft. The excessive heat caused by a runaway fire may damage the furnace safety controls. Their operation should be checked before the furnace is returned to service. After a soot or runaway fire inspect chimney connection and chimney.

MINIMUM INSTALLATION CLEARANCES FROM COMBUSTIBLE MATERIAL

Fire door end – 48"

One side – 6"

Other side (walkway) – 24"

Blower door end – 30"

Flue Pipe – 18"

Plenum and takeoff ducts to 6' from furnace – 6"

Duct beyond 6' from furnace – 1/2"

Floor non-combustible

DRAFT

FIG. 1 –FIREBOX INSTALLATION PROCEDURE

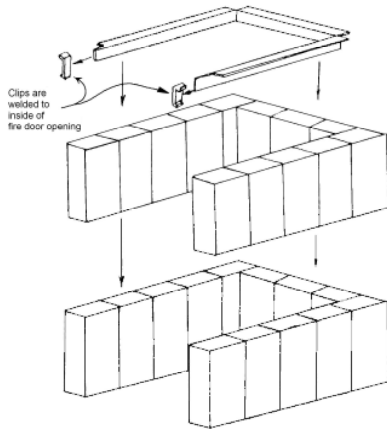

INSTALLING BRICK

1. Place one (1) brick on end in the center at back of furnace
2. Place brick lock in furnace brick lock hooks
3. While holding brick lock up, place one (1) brick on end on top of brick previously placed in back (this should hold brick lock up to correct height)
4. Install brick by starting at front, putting one (1) bottom brick in place then slide one (1) top brick in place. Repeat this procedure, going down both sides, and then do brick at back last.
5. Lower brick lock into place.

FIG. 2 –SECONDARY AIR INSTALLATION INSTRUCTIONS

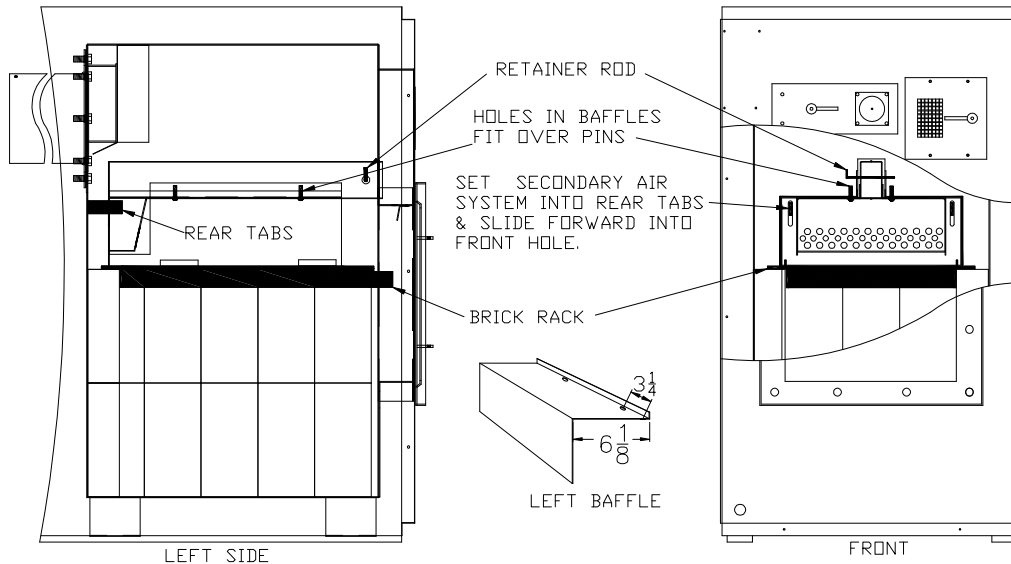

DRAFT

FIG. 3 - FURNACE WIRING
(when equipped with R8222A Relay or equivalent)

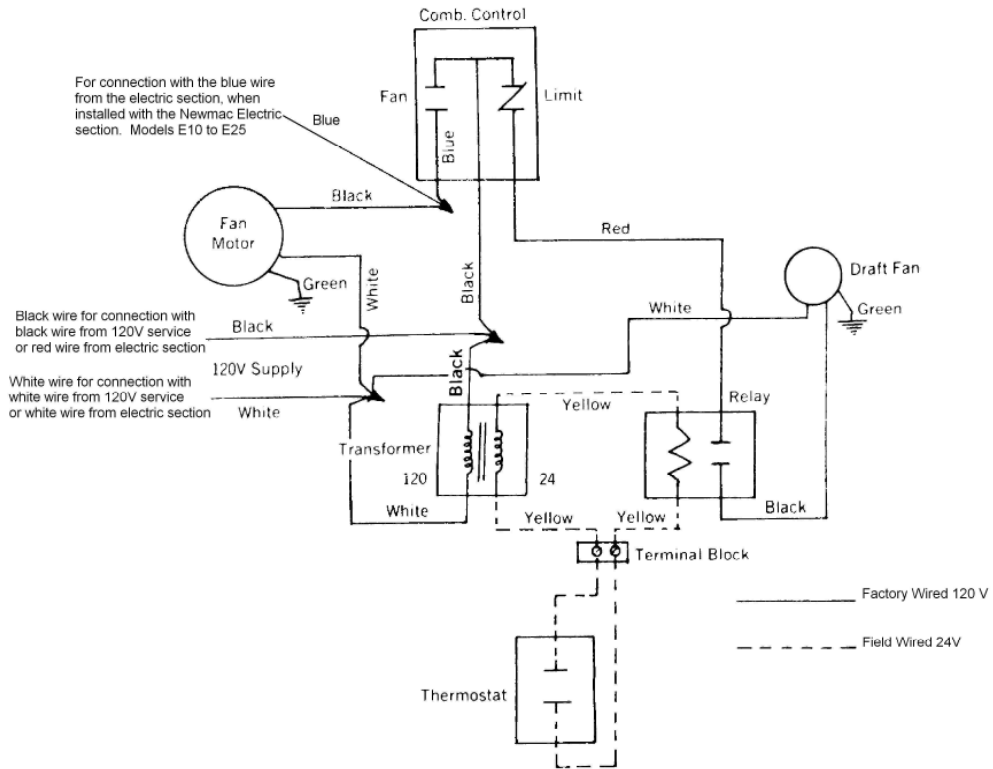

DRAFT

FIG. 4 – CONTROL LOCATION AND COMBUSTION AIR FLOW

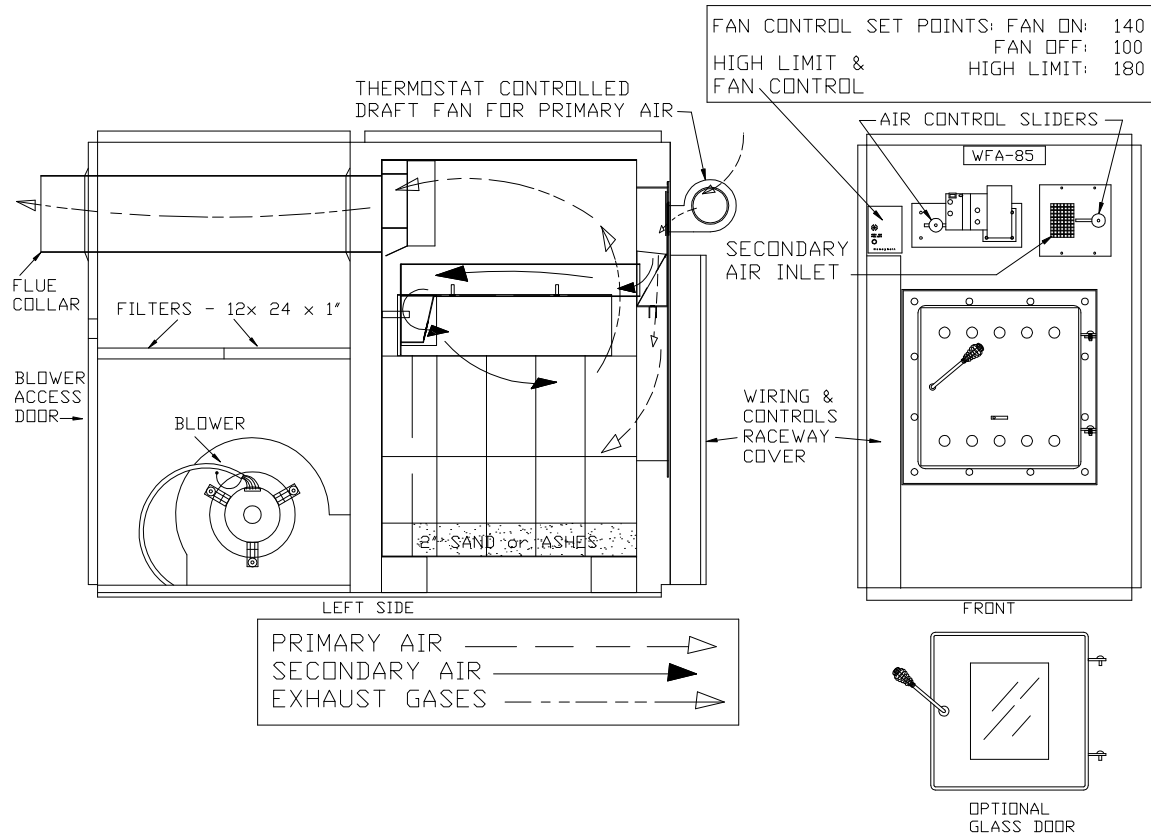

DRAFT

FIG. 5 – FURNACE PARTS LIST

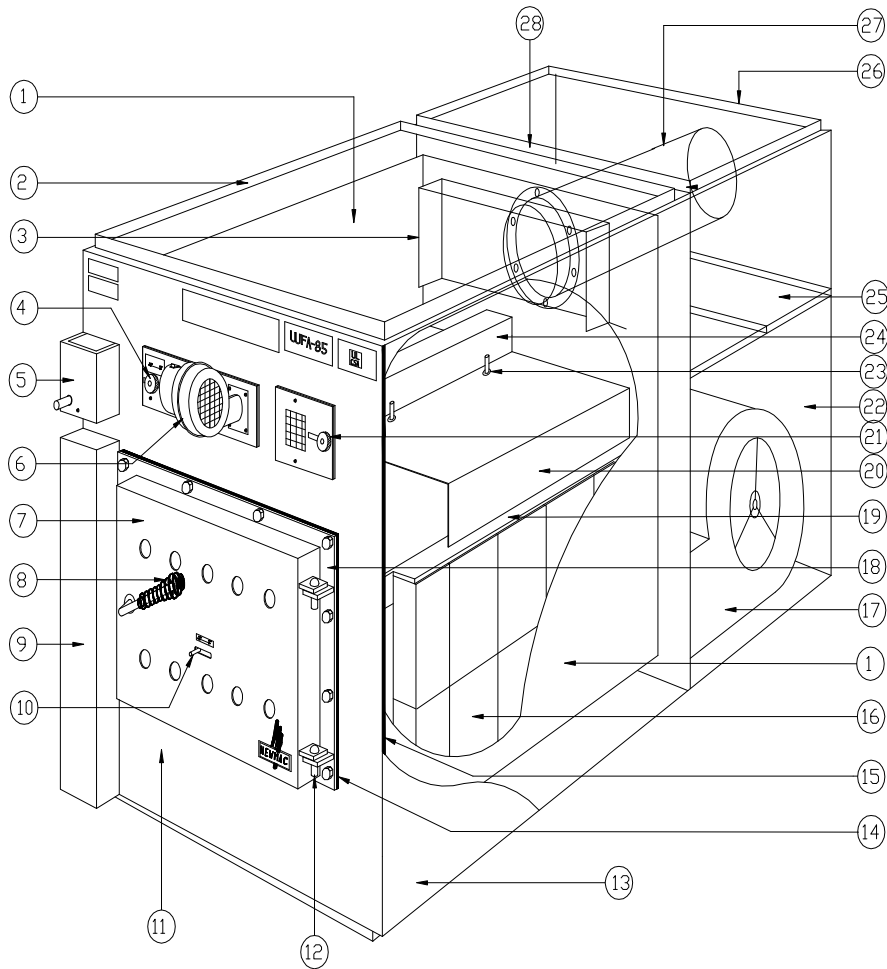

Part #	Description	Part #	Description
1	4060472 Heat Exchanger	15	Front Panel 1/4" White Gasket
2	4120211 Left Side Panel	16	2030010 Full Size Firebrick
3	Flue Baffle	17	2040103 Blower
4	5300012 Draft Slide Plate Assy	18	4110102 Door Frame
5	2010017 High Limit & Fan Control	19	4060468 Brick Rack
6	2040001 Draft Fan	20	3100714 Baffle (2 pieces)
7	4120507 Firedoor Assy Less Frame	21	Secondary Air Inlet Assy
8	5300009 Cool Sping Door Handle	22	41200321 Blower Access Door
9	Electrical Raceway	23	Baffle Pins
10	Door Slider	24	Secondary Air Channel
11	4120506 Front Panel	25	2180001 Return Air Filters (2) 12x 24x1
12	2160001 Door Pins (2)	26	Rear Flue Panel
13	Right Side Panel	27	4060469 Stainless Steel 7" Flue
14	Door Frame Gasket	28	4120421 Top Rail Panel

DRAFT

FIG. 6 – FIREDOOR BREAKDOWN

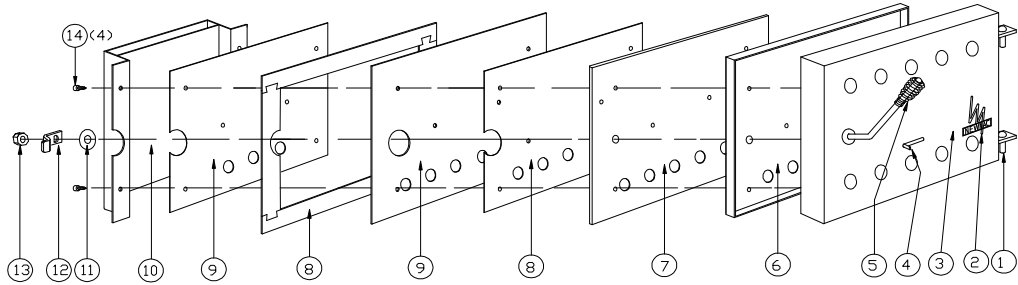

Part #	Discription	Part #	Discription
1	21600001 Door Pins (2)	8	
2	NEWMAC Logo	9	
3	Door with Slider assy	10	
4		11	
5		12	
6		13	
7		14	

DRAFT

FIG. 7 – PHYSICAL WIRE LOCATION

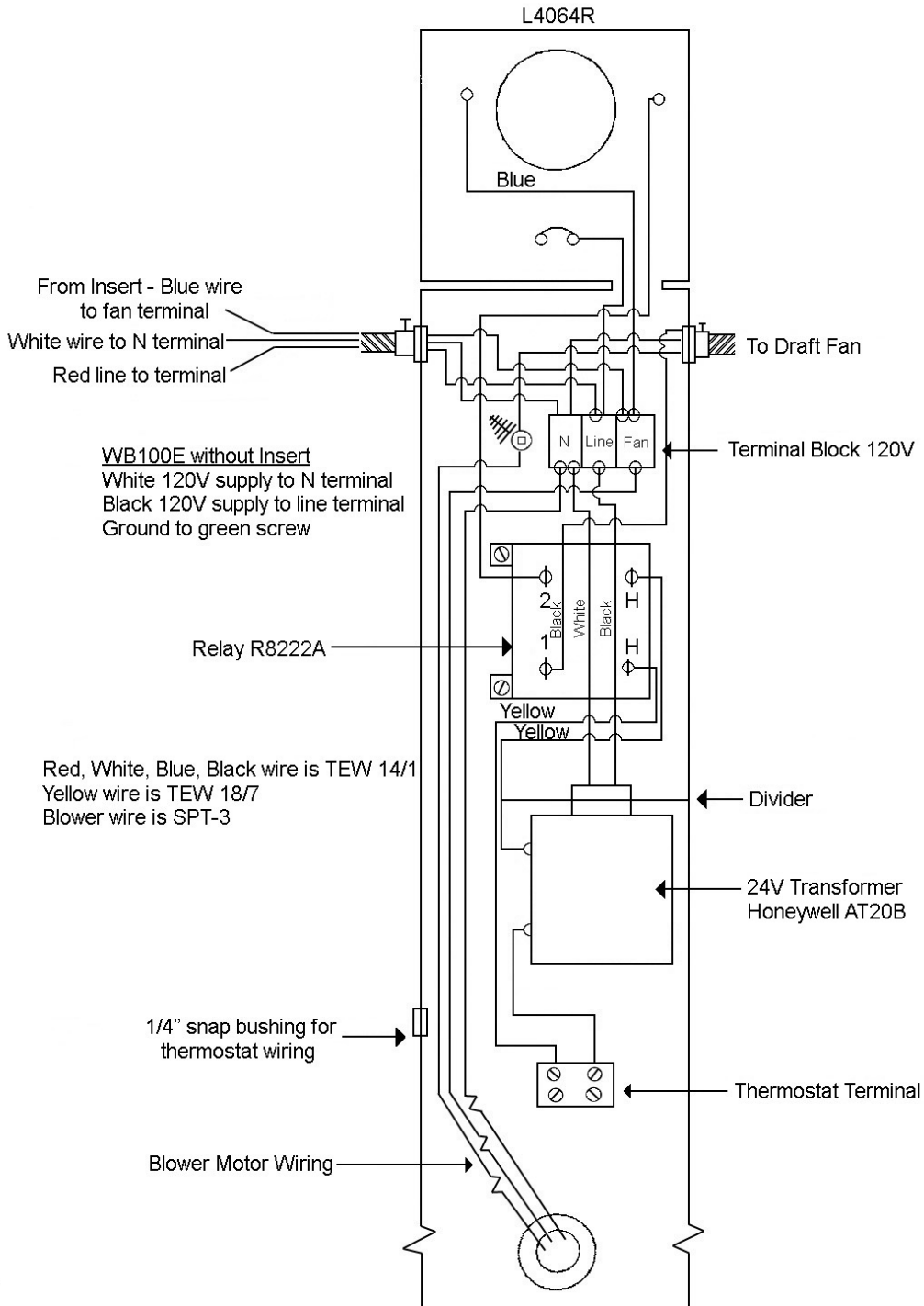

DRAFT

PREPARATION OF WOOD

Once I have my wood at home, how do I prepare it for burning?

The wood must be cut to length to suit the firebox of the stove of the appliance in which it is to be burned. A log may be cut into the desired length. Splitting the wood greatly facilitates drying and reduces the wood to a more manageable size.

How much moisture is contained in wood?

Many softwoods have a moisture content in the vicinity of 55 percent when they are freshly cut. The popular hardwoods have moisture contents of about 45 percent. Air dried wood has a moisture content of about 16 to 22 percent. Kiln dried lumber may have a moisture content of less than 10 percent and should never be used as firewood as this will over fire and damage your appliance and controls.

What causes wood to rot?

When wood is cut, it is very susceptible to the growth of fungi, which converts the wood to water, carbon dioxide, and heat, just as does a fire. This rotting decreases the wood's energy. The fungi are most productive when three conditions are met: the temperature is between 60^o F and 90^o F, the wood's moisture content is above 30 percent, and ample oxygen is available. Thus, wood does not rot appreciably when it is dry, in the winter, or when it is submerged in the water, but it should not be allowed to lie on the ground during the summer.

How can this rotting be prevented?

When the wood has been cut into stovewood lengths, and split, it should be piled outside during the months of June, July, and August. Two poles should be placed on the ground to serve as rails to keep the firewood off the moist ground and the wood should be piled up in such a way that it is well exposed to the sun and the wind. The moisture content of the wood will drop until it reaches equilibrium with the ambient weather conditions. When the relative humidity is 60 percent, the equilibrium moisture content is about 11 percent. When the wood has reached this equilibrium moisture content, it is said to be "air dried." Around mid August, it should be placed under cover so that it will not reabsorb moisture from the rain and snow before it is used.

Why this concern about allowing the wood to dry?

Green or wet wood is undesirable for several reasons. Green or wet wood tends to mildew and rot which causes a significant reduction in the thermal value. When green or wet wood is burned, it may take 20 to 25 percent of the thermal value of the wood heat to evaporate and drive off the moisture, which is contained. Green wood does not burn easily and, in order to keep the fire burning, it is often necessary to add a lot of fuel and provide excessive draft, thereby decreasing the efficiency of the unit. The excess air needed for combustion must be heated and it escapes up the chimney wasting heat that should be used to heat the house.

What is creosote?

Wood smoke almost always contains some unburned gases and a fog of unburned tar-like liquids. Some of these materials will condense on the inside of the chimney, just as steam condenses on any cold surface. This condensation is a black, tacky, fluid when first formed. When it dries, it is flaky and shiny. Creosote has approximately the same thermal value as fuel oil. Not only does it reduce the effective size of the chimney, but an accumulation of this material constitutes a serious fire hazard.

Does green wood cause creosote?

Yes. Indirectly, green wood does cause creosote. The exhaust gases cool as they rise up the chimney. If the temperature falls below the dew point, any moisture contained in these gases will condense on the inside of the chimney, absorb the various products of incomplete combustion and form creosote. When green wood is burned, the exhaust gases carry a high moisture content in addition, because of the heat required for evaporation, these gases are cooler and more likely to condense than would be the case with dry wood.

Charcoal may be formed more readily if the unit is overcharged, particularly in milder weather. With overcharging (too much wood in unit) the draft fan will be off a greater percentage of time, coals will be

DRAFT

formed which will become covered with ash and in turn will smother the coals to form charcoal. Any coals in the furnace should be stirred before more wood is added to it.

The preceding is an excerpt from a document prepared by the Nova Scotia Energy Council and the Nova Scotia Research Foundation Corporation.

CREOSOTE AND CHIMNEY FIRES

Wood combustion is never perfectly complete. Wood smoke almost always contains some unburned gases and a fog of unburned tar-like liquids. Some of these materials will condense out of the flue gases onto any surface which is not too hot. The condensate is usually dark brown or black, and has an unpleasant acrid odor. It is called creosote. If condensed on a relatively cool surface (such as an exterior stovepipe chimney), the creosote will contain a large amount of water along with the organic compounds, and will thus be very fluid. Water is usually absent if the condensation occurs on surfaces hotter than 150°F. The condensate may then be thick and sticky, like tacky paint or tar. Creosote may be found almost anywhere in a wood-heating system, from the top of the chimney to the insides of the cover itself.

Creosote which remains in a chimney after its initial formation may later be significantly modified both in physical form and chemical content. The water and the more volatile organic compounds tend to evaporate, leaving the more tar-like substances behind. If these are subsequently heated by the flue gases from a hotter fire (this usually happens), they themselves are further pyrolyzed to the same final solid product that wood is carbon. The physical form is usually flaky, and often shiny on one side. Partially pyrolyzed deposits can have a bubbly appearance. The flakes do not adhere strongly to a stove pipe and thus are easy to brush off; some of the other forms will not budge even under the action of a stiff wire brush.

The amount of creosote deposited depends mostly on two factors – the density of the smoke and fumes from the fire, and the temperature of the surface on which it is condensing. Highest smoke densities occur when a large amount of wood in relatively small pieces is added to a hot bed of coals and the air inlet damper is closed. Here, there is considerable pyrolysis of wood, but little combustion, and little air to dilute the smoke. In practice, creosote generation is higher during low-power, overnight, smoldering burns. Smoke densities are least when combustion is relatively complete, which tends to be the case when the amount of excess air admitted to the wood-burner is high. Leaky stoves, open stoves and fireplaces typically have the least creosote problems.

One way to lower the average smoke density in an airtight stove is to use less wood each time fuel is added, and/or to use larger pieces of wood. In either case, the air supply need not be turned down so much in order to limit the heat output and combustion is likely to be more complete. Of course, if less wood is added, stoking must be more frequent. A related procedure to limit creosote is to leave the air inlet moderately open after adding wood until the wood is mostly reduced to charcoal, and then close the inlet as much as desired. This will promote complete combustion during pyrolysis, when the creosote compounds are being formed, but there will be a significant heat surge while the gases are burning.

Extra air can also be added to the flue gases in the stove pipe; this is what the Ashley creosote inhibitor does. But the net effect of adding dilution air is not obvious or necessarily beneficial. Dilution air will decrease the smoke density, but it will also decrease its temperature. These effects have opposing influences on creosote formation. The National Fire Prevention Association states that dilution air increases chimney deposits. In any case, the cooling effect of dilution air does decrease the heat transfer through the stovepipe and chimney, thus decreasing the system's energy efficiency.

Creosote formation may also depend on the type of wood burned and on its moisture content. Dry hardwoods have a reputation for generating the least creosote, but the quantity can still be very large. No kind of wood eliminates creosote formation.

For a given smoke density near a surface, the cooler the surface, the more creosote will condense on it. The phenomenon is very similar to water vapor condensing on the outside of a glass of ice water on a humid day, except for an inversion – condensation occurs on the inside of a chimney, especially when cold air outside makes the inner chimney surface relatively cool. A stovepipe chimney outside a house on a cold day will be wet on the inside with creosote (including a lot of water) virtually all the time. A well insulated, pre-fabricated metal chimney has the least serious creosote problems; its insulation helps maintain higher temperatures on its inner surface, and its low heat capacity allows it to warm up very quickly after a fire is started. Masonry chimneys frequently accumulate deposits at the beginnings of fires and their interior surfaces take a longer time to warm because the construction is so massive. Any type of chimney which runs up the outside of a house is more susceptible to creosote problems than the same type of chimney rising in the houses' interior, due to the cooling effect of the colder outdoor air on the exterior chimney.

Average flue gas temperatures can be increased by minimizing the length of stovepipe connecting the stove to the chimney. This, of course, will also decrease the energy efficiency of the system, and it is often

DRAFT

true that measures which decrease creosote formation also decrease heating efficiency. For instance, stoves which have energy efficiencies due to their relatively good heat transfer (e.g. the Sevca, lange 6303 and double barrel stoves) are more likely to have chimney creosote problems precisely because they do such a good job extracting heat from the flue gases.

Generally creosote is inevitable and must be lived with. Any kind of chimney deposit decreases the system's heating efficiency. Soot and dried creosote accumulations have a significant insulating effect; less of the heat in the flue gases transferred into a house through dirty stovepipes and chimneys. The most annoying problem can be creosote dripping from a stovepipe or chimney, and the most dangerous problem is chimney fires, during which the creosote, or its pyrolyzed residue, burns.

Creosote dripping can usually be eliminated. Joints in vertical segments of stovepipe will not leak if, at the joints, the smaller, crimped ends always point down into the appliance. (Smoke will not leak out of the joints due to this direction of overlap.) Since this is not the usual orientation for stovepipe, a double male fitting may be necessary at some point to connect the stovepipe to the stove, a prefabricated chimney, or a rain cap. Special drip proof adapters are available for connecting some sizes of stovepipe to Metalbestos brand prefabricated chimneys. Common types of stovepipe elbows can leak creosote due to their swivel joints; rigid and accordion type leak proof elbows are available. Horizontal or gently sloping joints between horizontal pipes and/or fittings are the most difficult to seal against dripping. A good high temperature sealant can sometimes help, but is no guarantee. The joint must also be snug, and well secured with sheet metal screws. If all joints are made leak proof, then the creosote will generally drip into the stove, where, when the fire is hot, it will be burned.

Chimney fires occur when the combustible deposits on the inside of a chimney burn. The deposits may be 'raw' creosote, pyrolyzed creosote, or soot. Ignition requires adequate oxygen, which is usually available at sufficiently high temperatures, the same condition as for the ignition and combustion of any fuel. Chimney fires are most likely to occur during a very hot fire, as when cardboard or Christmas tree branches are burned, or even when a stove burns normal wood, but at a higher than normal rate. A crackling sound can often be heard at the beginning of a chimney fire. As the intensity of the fire rises, the stovepipe will sometimes shake violently, air will be very forcefully drawn in through the stove, and the stovepipe may glow red hot. A tall plume of flame and sparks can be seen rising from the top of uncapped chimneys.

The most effective way to suppress a chimney fire is to limit its air supply, although both water and salt are sometimes suggested if a relatively airtight stove is the connected appliance. This is easily done by closing the stove's air-inlet dampers, if all the stovepipe and/or chimney joints are tight, and if no other appliance is connected to the same flue.

In a properly designed and maintained chimney, the only potential hazard related to chimney fires is ignition of the building's roof or surroundings due to sparks and burning embers coming out of the top of the chimney. A spark arresting screen can decrease, but not eliminate this possibility, but spark screens themselves are often not suitable for use with wood fuel because they can become clogged. The chimney itself and the stovepipe, when properly installed, are intended to withstand an occasional chimney fire without danger of ignition of their surroundings. During a chimney fire, one ought to check the roof and surroundings, and possibly wet down critical areas. If the chimney may not be up to safety standards, one should also keep a close watch on all surfaces near the chimney.

Some people start chimney fires fairly frequently, as a means of chimney cleaning. This deters very intense chimney fires and the small ones which do happen are always under a watchful eye. Under some circumstances, this practice may be reasonable, but generally it is a risky method to keep a chimney clean. There is always some danger of a house fire, but in addition, any chimney fire is wearing on a chimney; the high temperatures increase the corrosion rate of metals and the thermal expansion of masonry materials encourage crack formation and growth.

Chemical chimney cleaners are available. Opinions on their effectiveness vary, but apparently when used regularly, and as directed, they work, and do not damage chimneys. The usual chimney cleaning method is the oldest human energy and some kind of mechanical tool. A stiff wire brush, a heavy chain (perhaps in a bag) hung with a rope and worked up and down from the top of the chimney, and very small brushes have all been used. Professional chimney sweeps are also reappearing.

Some people clean yearly, others after every few cords of wood burned, but there are so many factors influencing creosote build up that such generalizations are not appropriate in most particular cases. In new installations, or when changes occur (such as a different stove) the chimney should be checked frequently (after 2 weeks, then after a month, then after another 2 months, etc.) until it is clear how frequently cleaning is usually needed.

DRAFT

The preceding is an excerpt from "THE WOODBURNERS ENCYCLOPEDIA" published by Vermont Crossroads Press, Inc. – Dec., 1976.

WOOD IS A SAFE CLEAN AND ECONOMICAL FUEL

Species	Approx. Wt. Per Cord	BTU Per Air Dried Cord	Equivalent Value #2 Heating Oil Litre	Cost at 70.0 cents	Cost at 75.0 cents	Cost at 80.0 cents
Hickory	3595	30,600,000	827.4	\$579.18	\$620.55	\$661.92
Hard Maple	3075	29,000,000	784.6	\$549.22	\$588.45	\$627.68
Beech	3240	27,800,000	752.4	\$526.68	\$564.30	\$601.92
Red Oak	3240	27,300,000	738.7	\$517.09	\$554.03	\$590.96
Yellow Birch	3000	26,200,000	709.2	\$496.44	\$531.90	\$567.36
Elm	2750	24,500,000	662.8	\$463.96	\$497.10	\$530.24
Soft Maple	2500	24,000,000	649.2	\$454.44	\$486.90	\$519.36
Tamarack	2500	24,000,000	649.2	\$454.44	\$486.90	\$519.36
Cherry	2550	23,500,000	635.5	\$444.85	\$476.63	\$508.40
Ash	2950	22,600,000	611.4	\$427.98	\$458.55	\$489.12
Spruce	2100	18,100,000	490.1	\$343.07	\$367.58	\$392.08
Hemlock	2100	17,900,000	484.1	\$338.87	\$363.08	\$387.28
Aspen	1900	17,700,000	483.2	\$338.24	\$362.40	\$386.56
White Pine	1800	17,700,000	462.8	\$323.96	\$347.10	\$370.24
Basswood	1900	17,000,000	459.6	\$321.72	\$344.70	\$367.68

Note: To change litres to US gal. multiply by 0.264

For the least amount of wood handling, the wood with the highest heat content is most desirable.

An open fireplace can actually refrigerate a house because it sucks in so much cold air, which is only partially used for combustion. A carefully designed fireplace makes use of perhaps 10 – 15 % of the heat available; most still going up the flue. The well-constructed potbellies get perhaps 20 – 25 % and the automatic, draft regulated, tightly sealed non EPA wood heaters get perhaps 50 %.

Notice that the percentage efficiency goes up as the combustion process becomes more and more controlled. The roaring fire is a complete waste of fuel. The best situation is one where the combustion chamber is air-tight. This allows a controlled fire that toasts the wood and puts the right quantity of wood gas in the right place and at the right temperature for optimal combustion and heat transfer.

The NEWMAC COMBINATION OIL AND WOOD FURNACE toasts the wood to charcoal and the charcoal burns to dust leaving a minute amount of residue. From the above heat values, it can be seen that a cord or Hickory wood is equivalent to \$ 248.22 (@ 30.0 cents litre) worth of oil, over twice as much as you would pay for a cord of wood.

Without taking into account all the free wood that is available, EFFICIENT WOOD HEATING cuts your heating costs in half.

DRAFT

MAINTENANCE AND OPERATING BULLETIN

Regarding Solid Fuel Burning Heating Units

The following are some suggestions with reference to the above:

1. MAINTENANCE:

In addition to periodic cleaning, it is most important that the unit be cleaned thoroughly at the end of each heating season. Both the primary and the secondary heat exchangers should be given extra attention with a steel scraper or brush. This will help to prevent rust and corrosion during the high humidity summer months. Also, if the fire door is left open, it will allow for air to circulate through the units.

2. OPERATION

- a. When burning with wood, the minimum setting for the manual draft slide should be in the centre. (This is the slide knob beside the combustion fan above the fire door). The open setting is for initially starting a wood fire.
- b. Do not attempt to burn the solid fuel in the spring or fall when temperatures are mild. This will cause the unit to be shut down for extended periods at a time and will form creosote and soot.
- c. In the Solid Fuel units – burn the fuel at maximum draft with good dry wood for an hour or so (once or twice a week). This will help to prevent creosote build up.
- d. During the off season, in order to dry out the humidity in the unit, fire the furnace once a month for at least 30 minutes.
- e. The solid fuel furnace – build a fire with dry wood.

The above details, if adhered to, will extend the longevity of your furnace and provide many years of warm, comfortable heat.

DRAFT

INSTALLATION INSTRUCTIONS

Models E10, E15, E20, E25 Electric Heating Section For Solid Fuel/Electric Furnace Model WFA-85

GENERAL

It is the responsibility of the consignee of the unit to examine the package for damage and, if found, to note the same on the Carriers Bill of Lading.

This unit consists of one (1) package which has packed inside: electric heating unit, adaptor, bag of screws, installation instructions and thermostat.

INSTALLATION

1. This unit shall be installed in accordance with the regulations of the Canadian Electrical Code, CSA Standard, C22.1, and Local Governing Bodies.
2. These instructions do not supercede local codes in any way. Local authorities having jurisdiction should be consulted before installation.
3. Consult the Installation, Operating and Service Manual shipped with the furnace for proper installation of the solid fuel burning unit.
4. Mount the Electrical Component as shown in the accompanying diagram.

DUCT INSTALLATION

1. Before installing the supply air plenum, check that the heating elements are free of foreign material and are not damaged.
2. Install ducting with minimum return air duct size equal to 250 sq. in. and with minimum supply air duct size equal to 180 sq. in. A minimum of 6" clearance above the warm air and return air plenums and takeoffs should be maintained for a distance of 6 feet from the furnace. Beyond 6 feet there must be a minimum of 1/2" clearance.

WIRING INSTALLATION

1. This furnace must be connected to a separate fused disconnect switch supplying power to the appliance. The furnace must be suitably grounded.
2. Install the BX cable containing three wires from the Electric Section to the existing knock-out of the furnace.
3. The white wire in the BX cable from the electric section is connected to the common or white wire existing on the furnace, for standard installation.
4. The red wire in the BX cable from the electric section is connected to the existing black wire coming from line terminal of the L4064 fan limit control, for standard installation.
5. The blue wire in the BX cable from the electric section is connected to the single blue capped wire provided, which operates the circulating blower of the solid fuel furnace.

24 VOLT WIRING ONLY (THERMOSTATS)

1. Install the two thermostats beside each other and in accordance with the instructions packed with them. Set the heat anticipators to 0.4 amps.

(Refer to FIG. 9)

2. Connect one wire from electric thermostat to Terminal C on top of Electric section.
3. Connect second wire from the electric thermostat to the screw on the 24V AT20B1007 transformer (that supplies relay) which is located in the control panel of the solid fuel unit.
4. Connect one wire from solid fuel thermostat to Terminal G on top of the Electric section.
5. Connect second wire from solid fuel thermostat to Terminal Block coming from relay on the solid fuel furnace control panel.
6. Connect wire from Terminal R on top of Electric section to remaining Terminal of the terminal block located in the control panel of the solid fuel unit.

DRAFT
FIG. 8 – 240 VOLT SUPPLY

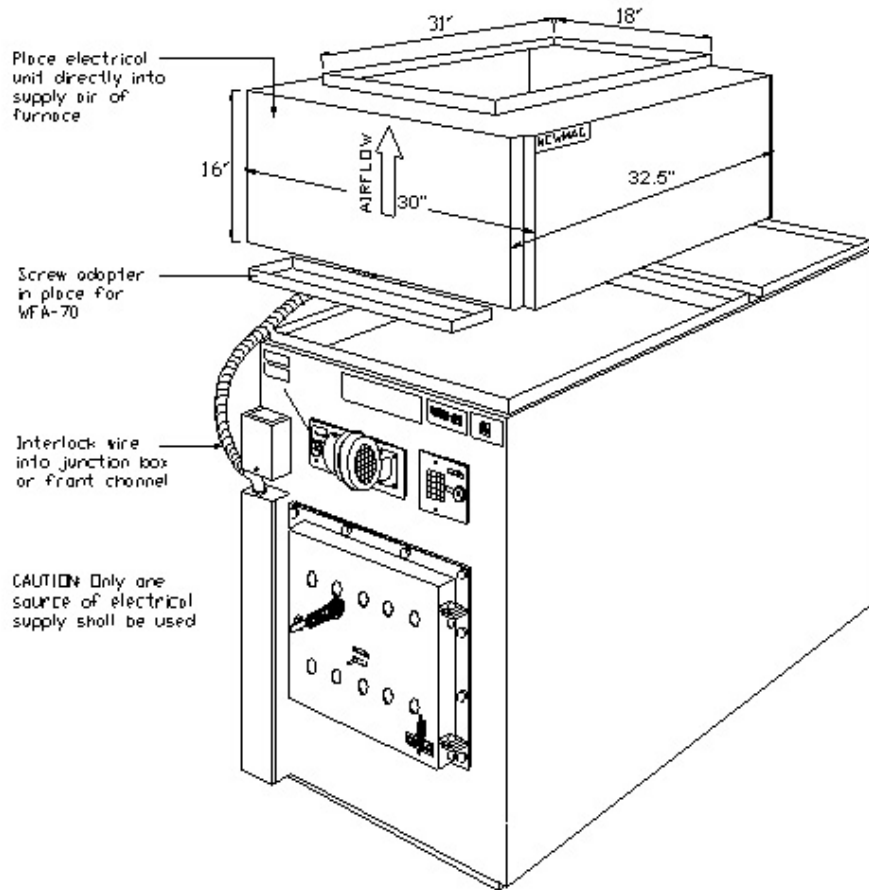

DRAFT

FIG. 9 – WIRING WFA-85 & ELECTRIC INSERT

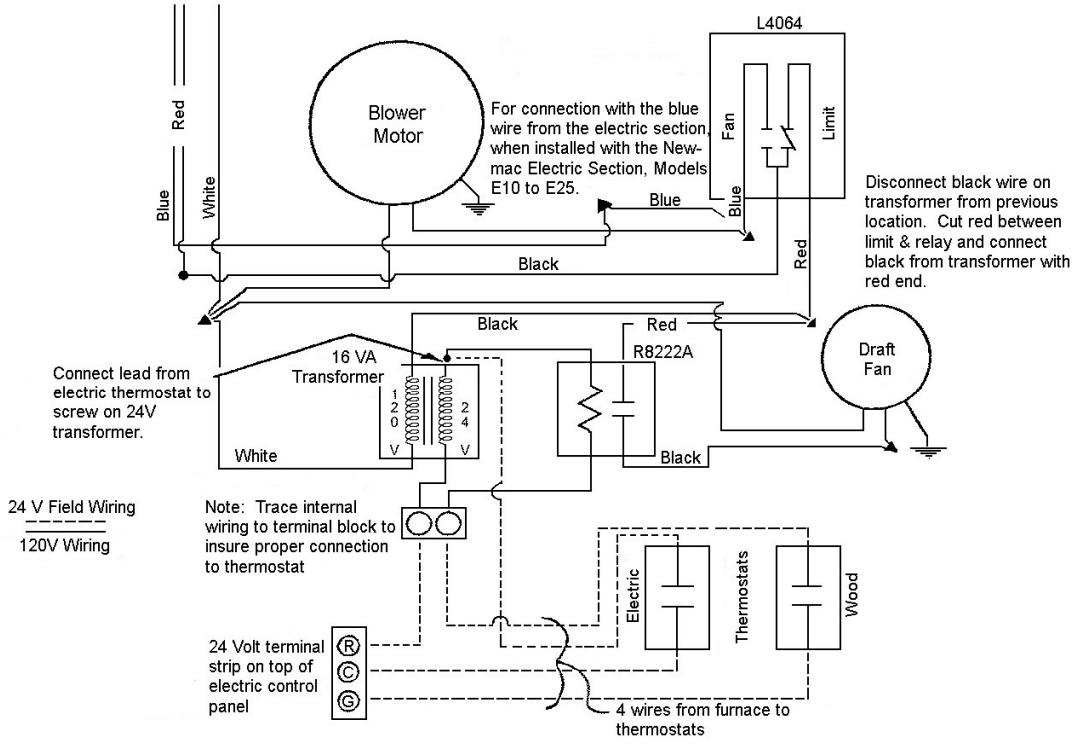

DRAFT

NEWMAC SOLID FUEL HEATING UNIT "LIMITED" WARRANTY

Subject to the following provisions Newmac Mfg. Inc. (Newmac) warrants the heating unit, to the original owner, under normal use and repair, against defects in workmanship and materials, for a period of one calendar year from the date of original installation.

THE NEWMAC EXTENDED CONDITIONAL HEAT EXCHANGER WARRANTY PROGRAM

(Warranty protection calculated from date of original installation)

Table with 3 columns: Period, Owner Warranty Protection, and Owner Replacement Charge. Rows include: First full year, From year one through year two, From year two through year four, From year four through year six, From year six through year eight, From year eight through year ten, From year ten and over.

NOTES:

- 1. Owner Replacement Charges are expressed as a percentage of the replacement retail price prevailing at the time of replacement purchase.
2. Newmac is NOT responsible for:
A. Labour charges generated by removal of malfunctioning component and re-installation of replacement component.
B. Freight charges generated by any form of transportation of replacement component.
C. Any applicable sales tax generated by the purchase of replacement component.
D. Corrosion is not covered under warranty regardless of cause.

General Conditions and Limitations

The heating unit must be installed by a qualified licensed installer with the Newmac installation instructions. The heating unit must also be installed in accordance with all applicable codes and the National Warm Air Heating and Air Conditioning Association Standards or generally accepted equivalent standards.

The heating unit is NOT designed, or intended for use in a corrosive atmosphere (such as a concentration of acids or halogenated hydrocarbons). The installation, and operation of the unit in such an environment, will be considered as gross misuse, and all warranties will be automatically invalidated.

The heating unit must not be modified away from its published design and/or specifications without prior written authorization, for such modification, from Newmac.

The heating unit must be correctly sized to operate at its designed capability.

The heating unit must be correctly fueled to operate within its designed function.

The heating unit must be maintained and cleaned at regular intervals, and in accordance with instructions contained in the Newmac owner's manual.

Failure to comply with all the above stated qualifying conditions, will render the Newmac Warranty null, and void in its entirety.

This warranty is the only warranty made by Newmac, and furthermore, Newmac does not authorize any person or company to change, or alter, the conditions under which this warranty is provided. Newmac does not authorize any person, or company, to provide any other warranty on its behalf.

For routine service requirements, contact the dealer who installed the equipment originally or an alternate qualified and registered heating dealer or electrician.

As previously stated herein, Newmac does not assume responsibility for costs of delivery or labour charges involved in the replacement of defective component parts.

Newmac shall not be responsible for any consequential damage however caused whether by a defect in the heating unit or any part thereof warranted hereunder or by the negligence of any person.

This warranty is not effective unless the warranty registration card is properly filled out with all of the required information and received at Newmac's factory at the address below within (30) days from the installation date.

NOTE: Keep this warranty certificate and the instruction manual for future reference.

LIMITED WARRANTY REGISTRATION

PLEASE PRINT OR TYPE:

Owner's Name.....
Address of Installation.....
Date of Installation.....
Dealer's Name.....
Dealer's Address.....
Furnace Serial No.....Furnace Model No.....

Newmac Mfg. Inc., P.O. Box 9, Lancaster Cr., Debert, NS B0M 1G0