

rotor

Rotor (UK) Limited

TECHNICAL MANUAL

Surface Vibrators
“FO”, “NO” & “NA” Series



The present “ Technical Manual ” is applicable for surface vibrators series "FO", "NO" and "NA" with circular vibration and establishes the substational qualitative and delivery information for ensuring controlling the faultless installation, operation, servisingand controlling the rightness function of machines in order to eliminate not only deteriorate characteristic of the product to prevent any future damages.

This Technical Conditions of course can't include all possibilities regarding installation , function or services. It's assumed therefore, that the qualification, workmanship and experiences of the skill-worker prescribing the regulations, which must be used in the concrete machinery.

1.Nomenclature

1.1.Generally

The surface vibrator with circular-vibration is a special asynchronous three-phase squirrel-cage inductionss electric motor. Both side of motor shaft ends are provided with unbalancing weights for mechanical production of centrifugal force.

1.2.Identification



In the joint provisions the term “surface vibrator” or just “vibrator” will be used.

2.General

2.1.Application

The surface vibrators generate the curvilinear oscillations of frequency, which is

determined by the number of the integrated motor pole pairs and by the grid frequency existing in the place, where such oscillation shape can be applied for example:

- § Concrete mixture compacting (vibration tables, sills, slabs, battens) in constructions
- § Compacting (jolting) of materials in the industrial sectors like foundries
- § Loosening and cleaning of varied kinds of stuff in storage tanks, mould boxes and mine wagons and reducing of angles of repose (e.g. in hoppers)
- § Machines operating at circular or curvilinear oscillating motion (vibrating screens, washing machines etc.).

The pair of automatically synchronized counter - running vibrators with parallel axes operating as exciters of curvilinear oscillation are using for :

- § Horizontal vibrator conveyers
- § Vibrator feeders
- § Vibrating separators/screens
- § Machines using rectilinear, curvilinear or helical oscillations (special sorters, wiping, washing, miming and material draining equipment and another applications).

A vertical vibrating conveyers as well as another technological machinery are using the pair of automatically synchronized surface vibrators with non parallel axes operating as exciter of screw oscillations.

These Technical Conditions do not rule out other desired special applications of the vibrators..

2.2.Description

The surface vibrator is in fact a special asynchronous squirrel-cage three-phase electric motor with unbalancing weights, which are fixed on both side free-shaft-ends and when rotating, generate mechanically the eccentric force. The built-in stator packet is pressed in the robust cast-iron casing body. The copper winding is protected against shocks with impregnation class “F” (CSN 330250). Generally the surface vibrators are delivered with standard voltage 230/400 V, 50 Hz (CSN IEX 38) but, of course, on demand is also possible to deliver vibrators on any other voltage or frequency.

The vibrators are held by robust feet cast together with the casing stator body as one unit (serie “FO”, “NO”) or with separate bearing shields (serie “NA”) and

provided with holes for the fixing bolts. The shaft is mounted in to special rolling bearings rated for a special dynamic stress. The bearings are held in the casing by two bearing shields of the same material as the casing.

The two pairs of unbalancing weights are simply clamped on both side free-shaft-ends (unbalancing weights are external/internal parts).

Springs ensure the constant position of the external unbalancing weights; while the internal ones after the clamping bolts been loosened can be fluently turned and properly adjust the required unbalancing weight moment as well as to change the centrifugal force from “NO” to the maximum by the scale provided on the external unbalancing weights. This adjusting must be done same on both sides of vibrator.

The unbalancing weights on both sides free-shaft-end are covered by alu-alloy cover. The connections between the body and cover as well as terminal board cover are provided with “NO” - packing rings. The same packing protection is between bearing shields and casing body. The inlet terminal board with screw terminals is mounted in the terminal board cover, which is integrated in the cast casing. The bottom portion of the terminal board cover with the bolted-on terminal plate and attached outlets of the integrated electric motor and rated to the required grid voltage is embedded in silicon rubber. The remaining space is filled with the readily removable silicon putty, which is held by the terminal board cover lid. The supply cable was connected before the putty had been pressed in. The cable is protected at the outlet from the terminal board with screw plastic gland.

The “NA” series differ in the design from the “NO” and “FO” by having the feet cast as one unit with the bearing housings.

3. Protection and work safety

Before mounting the vibration motor on the excited device is necessary to compare the voltage and frequency with the rating plates of the integrated electric motors and vibrators.

Before carrying out maintenance, mounting or dismantling of the vibration motors, changing of M_N and any kind of repair, stop and plug out the vibrator.

The protection against the dangerous contact voltage is provided by neutral connection, for vibrators in mines by earthing.

The vibrators are determined for use in industrial power - current installations. At gear - (operation) are some parts under current, some parts are rotating and moving. For this reason uncompetend remove of cases, defective use or

insufficient service could cause serious (injure) of persons or damage on the property (estate). Therefore the person responsible for safety work of electric device should secure:

- § Only the (skill worker) should work on the device.
- § All those workers on this device (machine) should have at their disposal instruction books and other documents supplied to devices. There instructions must be always observed (adhered).
- § Only skilled workers could work on this machines and devices or in nearness.

Skilled workers are the persons with a special education experience and knowledge of relevant norms, technical conditions, regules of the first aid and working conditions.

They should be put in charge to that work by the person responsible to work safety in the factory. The persons must be able to discern possible dangers (perils) and prevent them. Skilled workers should observe the valid National Electr. Rules for the safe service (altern. dance) of vibrator. Also the basic planning work for installation, transport mounting, service and repair of the device should be executed and controlled by responsibly qualified workers. The protection against accident correspond to CSN 33200-4-41.

All devices excited by the surface vibrators must be in compliance with the regulations for health protection, noise nuisance and adverse effect of mechanical oscillation and vibration.

The vibrator should not be connected with device without protection against short-circuit, and overloading. It should not be connected other than is intended for and unless the unbalancing weight covers are in place.

ATTENTION - before any kind of service, maintenance, mounting or dismounting of vibrators, changing of M_N and or any kind of repair; **“STOP AND PLUG OUT THE VIBRATOR FROM DEVICE.”**

4.Operation and Service

Mount the vibrator on an even, degreased and cleaned plate. Clean the vibrator contact surface of dirt and lubricants. Before startling the vibrator check the tightness of the connecting bolts and their securing against loosening.

Before connecting the vibrator to the electric mains check, if the voltage and frequency match the vibrator rating plate. The electric wiring of the vibrators should be duly rated to prevent the overload and damage of the integrated electric

motor. Connect the vibrator over the specified over current relay adjusted not higher than 10 % over the rated current of the vibrator. For connection of one vibrator or a pair of vibrators see Enclosure.

By regulation with frequency changer should not be overrun the revolutions named in this Tech. cond. and on the Name Plate because it can cause the crash.

Before starting the vibrator it is noting to check again:

- § *Tightness of the connecting bolts,*
- § The over all isolation and condition of the wiring,
- § The connection cable must be fare hanged and placed in such distance not to be teared.

If the vibrator has stopped by the operation of the over-run relay, check, if the vibrator does not drain in all phases the rated current higher than that specified on the rating plate. If the drained current is higher than the rated one or the differences between the phases exceed the admissible deviation of 10 %, find the cause of the overload. The overload may have the following causes:

- § wrong grid voltage,
- § the vibrator connecting bolts are loose,
- § excessive oscillations of the excited device owing to the wrongly adjusted unbalancing weight moment, use of wrong vibrator, wrongly adjusted frequency of the excited system, etc.,
- § impacts of the excited device against the surrounding solid objects as a consequence of wrong mounting and insufficient clearance around the oscillating parts, which is needed (the clearance) for start, stabilized oscillation and rundown of the vibrator.,
- § instability of the exciter auto synchronization generated by the vibrator pair due to wrong conception and insufficient rigidity of the device excited and/or loose bolt joints, the consequence of which is the impairment of the integrity of the vibrator of the flexible system of the excited set,
- § wrong construction of the device, which (the construction) does not allow the vibrator to overrun the proper frequency of the set excited,
- § defects in the vibrator connection with the grid or in the winding of the integrated electric motor.

To readjust the vibrator unbalancing weight moment, stop the vibrator, disconnect it from the grid by loosening the adjustable clamping bolts of the internal unbalancing weights. Re-adjusting unbalancing weight moment should be realized when vibrator is stop or disconnected from device. After taking off the covers

above U.W. and loosening the screw on internal U.W. is possible to turn the internal U.W. against external U.W. Then it is notting to tight properly the clamping bolts on prescribed "M" (moment). The adjustable internal U.W. have the collared edge, the fixed external U.W. are provided with a

cale intended for the adjustment of U.W. moment (centrifugal force) in terms of % Mn maximum (maximum centrifugal force). Adjustment of U.W. on both ends of shaft must be same.

The running vibrator shall not be exposed to adverse external effects, like surrounding temperature over 40⁰ C, strong sun radiation or other heat radiation or transfer of heat from the conveyed stuff. The temperature of the integrated electric motor measured on the casing surface shall not exceed 65°C and the resulting temperature 105°C. (the integrated electric motor is rated for class F temperature). The temperature of the bearings measured on the bearing housings shall not exceed 50°C and the resulting temperature 90°C. Higher temperature (over this boundary) impairs the functional life of the lubricants and bearings. The vibrator should not operate in the environment saturated with water, oil and caustic vapours or in environment which is at variance with its protection rating and corrosion protection. Protection class of vibration correspond to IP 65, CSN 6034-5 (350000).

Maximum admissible starts of the vibrator of the basic construction: 30 starts per hour. Higher number of starts (more than 50%) is possible after adaptations arranged with the producer.

The electric wiring for connection of the vibrator to grid has to meet the provision of the following basic standards and requirements:

- § Electric Equipment of Working Machines CSN EN 60 204-1,
- § General Regulations for Protections against Dangerous Contact Voltage CSN 332000-4-1
- § Asynchronous Motors and in mine environment CSN 34 1410.

The binding basic wiring diagram of a one vibrator or pair of vibrators is shown in enclosure. The pair of auto synchronous vibrators shall never be connected go grid separately, since the outage of one vibrator may cause the destruction of the winding the other motor.

The connection cable 4Bx1,5 CGTG for vibrator FO1, FO2, NO1, NO2, NO3 and NA3, the connection cable 4Bx2,5 CGTG for the others vibrators are recommended by producer.

5.Maintenance

Before any work on the vibrator - device must be disconnected! Beside the main current circuit is important and necessity to disconnect subsidiary and additional current circuits too.

The five general regulations must be always remembered:

1. To disconnect
2. To ensure against connecting
3. To ensure no voltage state
4. To earth and make short - circuit
5. To cover and limit all surrounded under voltage parts.

The cancellation of the above five regulations only when maintenance is ended and surface vibrator ready on running again.

The following principles are applicable for the vibrator maintenance:

- § Check once every 1, 8, 100 and further every 300 operation hours if the connecting bolts are retighten and secured.
- § The bearings are greased by the manufacturer in time of the assembly for ever. Service life of the grease is the same as service life of bearings. It is not necessary to grease the bearing in course of working (service).
- § Remove the dirt if it has settled on the vibrator surface in such amount, that it might impair the cooling efficiency of electric motors and bearings.
- § Check the integrity of the supply cables, the overall condition of the wiring, the integrity of the neutral connection or earthing.
- § Check the condition of the insulation, particularly after extended storage of the vibrator.

The manufacturer carries out all other operations and maintenance work (replacements of bearings plus first grease filling, repair of electric motor windings, etc.) for the indigenous users also outside the guarantee period. It is not recommendable for the buyer or user to make the repairs or to interfere with the internals of the vibrators..

6.Technical Requirements

The technical data are shown in tables - see enclosures.

6.1. Material

The material employed for the manufacture must be in compliance with the production documentation. Employment of other material must be approved by the commissions for material changes.

6.2. Execution

All manufactured components must be in compliance with the production drawings. The dimensions for which the tolerances are not specified have to correspond to standard ISO 2768.1 and ISO 2768.2.

The vibrators are rated for the boundary parameters stipulated in the present Technical Conditions and for constant operation in heights over the sea level to

1 000 m. The protection class of the vibrators is IP 65 against dust and water. *They should not be used in environment with danger of explosion.*

The connecting bolts have to be surface treated (zinc-, nickel-, or chromium - plated). The bolts and nuts must be precise, bolt material of 8G or 10K

The integrated electric motor windings and connection of the vibrators to the supply cable shockproof.

6.3. Surface Treatment

The vibrator is provided with prime and to coats as per the production documentation.

6.4. Name Plate Marking

The vibrator must be provided with a data on name plate as follows::

- § Manufactur's address
- § Type identification
- § Production
- § Number
- § Year of manufacture
- § Voltage and frequency network
- § Nominal current and RPM/min

-
- § Maximum centr. force (N)
 - § Weight
 - § Identification of protection IP
 - § Class of insulation
 - § Inspector's identification.

7. Quality Test

The manufacturer's quality inspection division inspects the vibrator components in line with the approved documentation, technical standards in force and the technical conditions.

The quality tests and inspection of every assembly parts are carried out in line with the "Test Regulations for Vibration Motors" and a certificate testifying the test results will issued.

8. Ordering

The order of attaching vibrators must contain:

- § The number of pieces (quantity)
- § The type of vibrators
- § Operating required voltage and frequency. If the voltage and frequency are not given in order, the vibrators are delivered for 400 V and 50 Hz. All differences in construction and special requirements is necessary to settle with manufacturer before ordering.

9. Verification of Compliance with the Contract, Delivery and Guarantee

The verification of the compliance with the contract is carried out in the manufacturing plant in presence of the buyer's agent only on the basis of requirements specified in the contract. The supplier communicates the buyer the date of the verification procedure ten days in advance. If the buyer' agent fails to come, the final inspection department men carry out the tests by themselves and issue the quality and completeness certificate.

The manufacturer is committed to make available to the buyer all data and aids

required for the inspection..

All products as specified in the “Tests”, “Execution” and “Surface Treatment” sections are inspected. If the buyer requests other tests, there must be made an agreement, an autonomous order and the expenses in such case bears the buyer.

If the product fails to meet the conditions of the acceptance test, the shipping will be stopped and the repeated acceptance procedure goes to the expenses of the supplier, who is committed to renovate the buyer.

Both the supplier and the buyer are committed to adhere at the acceptance procedure to the economic codes № 45/83 (hereinafter EC/§ 192-197), compete text. The supplier’s quality inspection division is to stamp on the rating plate the symbol of the inspector who participated at the acceptance procedure and issues the quality and completeness certificate.

Each vibrator is delivered along with:

- v Product quality and completeness certificate
- v Technical Conditions.

The supplied vibrators are connected in 3x400 V (50 Hz) and their unbalancing weights set at $M_n = 0$, I.e. at the zero centrifugal force except the surface vibrators type FO12, NO12, NO14 and NO16 where working moment is adjusted on maximum.

Before connecting the vibrators to the electric mains it is noting do adjust it according paragraph 4.

9.1.Guarantee

The manufacturer quarantines design, function, employed material and construction of the vibrators for 12 months from the date of sale to the direct user, but not longer than twelve months from the date of delivery carried out by the manufacturer. For the bearings guarantee only for their service life, not longer than 12 month.

The manufacturer is committed to make good at his expenses all defects caused by faulty design, faulty construction or faulty material, provided that the buyer applies the quarantine without unnecessary delay after the defect has been located, but not later than by the last day of the guarantee period.

The buyer is not entitled to the guarantee repair in the following cases:

- v If the product is employed for other purpose or in other way than it is intended for as stated in the present Technical Conditions as normal operation or as

specified by a special agreement.

- v If the product is unduly stored, incompetently attended and maintained, if unsuitable lubricants are employed, if the service manual has not been adhered to, or if it has been damaged by a third person.
- v If the buyer has made changes or has had made changes on the product without the previous manufacturer's written approval. If the electric motor has been damaged due to the failure to adhere to the specified connection and protection as per the present Technical Conditions.
- v In case of natural wear.

The guarantee and post-guarantee repairs are carried out by the manufacturer.

10.Packing, Transport and Storing

The vibrators are delivered unpacked. If packing is required, the type of packing and package must be stipulated in the contract.

The vibrators must be stored in the space, where they would be protected against adverse atmospheric effects, excessive moisture, caustic vapours and mildew. For the transport of the vibrators the usual covered transport devices should be used. During transport should be the vibrators properly fastened (fixed).

Enclosures:

- № 1 Elementary Data
- № 2 Electric Data
- № 3 Dimensional Sketches
- № 4 Dimensional Data
- № 5 Basic Wiring Diagrams
- № 6 Types of Vibration
- № 7 Connection of Terminal Board
- № 8 Adjustment counterweights to maximum and minimum
- № 9 Recommended tighten moments

Enclosure № 1

Elementary Data 50 Hz							
Type	Rated speed [1/min]	Max. static moment [kg mm]	Max. centrifugal force [N]	Weight [kg]	Maximum admissib. amplitude		Teoret. live of bearings [hod]
					Deflect.* [mm]	Accel** [mm]	
FO12/6	6 000	7	2 800	7	0,6	110	1 000
FO22/6	6 000	19	7 345	21	0,6	110	3 000
NO02-250	2720	2,5	250	3,8	1,1	110	2 000
NO02-515	2 720	5,2	515	3,8	1,1	110	2 000
NO02-805	2 720	8,2	805	3,8	1,1	110	2 000
NO02-1090	2 720	11	1090	3,8	1,1	110	2 000
NO12	2 840	28	2 800	7,2	1,1	110	2 000
NO22	2 870	74	7 345	22	1,1	110	6 000
NO32	2 900	139	13 725	37	1,1	110	6 000
NA32	2 905	209	20 720	65	1,1	110	6 000
NO14	1 365	50	1 230	8,2	4,1	100	11 000
NO24	1 410	224	5 525	26	4,1	100	11 000
NO34	1 435	492	12 155	39	4,1	100	11 000
NA34	1 450	830	20 490	74	4,1	100	11 000
NA44	1 460	1 276	31 495	100	4,1	100	11 000
NA54	1 450	1 975	48 745	153	4,1	100	11 000
NA64	1 465	3 165	78 090	250	4,1	100	11 000
NO16	890	75	820	9	10	100	21 000
NO26	910	428	4 695	33	10	100	21 000
NO36	930	876	9 615	52	10	100	21 000
NA36	950	1 845	20 200	93	10	100	21 000
NA46	965	2 553	27 995	120	10	100	21 000
NA56	970	3 951	43 328	185	10	100	21 000
NA66	975	7 030	77 130	320	10	100	21 000
NO28	690	547	3 370	37	14	90	100 000
NO38	690	1 133	6 990	58	14	90	100 000

* With harmonic oscilation in arbitrary direction in vertical level on axis of shaft.

** In arbitrary direction in vertical level on axis of shaft and in axial direction max 20 ms⁻².

Enclosure № 2

Electric Data 50 Hz						
Type	Rated Output [kW]	Rated Current [A] for Voltage [V]		cos φ	η	I_v/I_N
		3x400 [V]	3x500 [V]			
FO12/6	0,15	0,37	0,30	0,8	73	5,3
FO22/6	0,37	0,87	0,69	0,87	71	6,7
NO02-250	0,06	0,24	0,23	0,68	44	5,5
NO02-515	0,06	0,24	0,23	0,68	44	5,5
NO02-805	0,06	0,24	0,23	0,68	44	5,5
NO02-1090	0,06	0,24	0,23	0,68	44	5,5
NO12	0,15	0,37	0,30	0,8	73	5,3
NO22	0,37	0,87	0,70	0,86	71	6,7
NO32	0,75	1,75	1,41	0,8	77	7,5
NA32	2	4	3,2	0,86	84	7,5
NO14	0,12	0,4	0,32	0,7	62	3,3
NO24	0,37	1	0,81	0,78	68	4,4
NO34	0,75	1,8	1,44	0,76	79	5,4
NA34	2	4,6	3,7	0,75	84	7,5
NA44	2,7	5,5	4,4	0,83	85	7,5
NA54	3,5	7,0	5,6	0,84	86	7,5
NA64	5	9,6	7,7	0,85	88	7,4
NO16	0,06	0,27	0,21	0,63	50	2,3
NO26	0,27	0,89	0,71	0,71	62	3,1
NO36	0,55	1,6	1,3	0,71	70	3,8
NA36	1,1	2,8	2,2	0,71	80	4,9
NA46	2	5,1	4,1	0,68	83	5,7
NA56	2,7	6,9	5,5	0,68	83	6,3
NA66	4,5	12,4	9,9	0,68	86	5,7
NO28	0,13	0,51	0,32	0,69	67	3,3
NO38	0,27	0,83	0,85	0,61	60	2,7

Enclosure № 3

Type	Dimensional Data [mm]						50 Hz				
	A	B	C	D	E	F	G	H	I	K	
FO12	27	70	260	140	27	167	30	158	63	4 x 14	M12
FO22	36	120	292	190	36	226	45	216	101	4 x 18	M16
NO02-250	70	40	192	100	20	120	12	129	48	4 x 9	M8
NO02-515	70	40	192	100	20	120	12	129	48	4 x 9	M8
NO02-805	70	40	192	100	20	120	12	129	48	4 x 9	M8
NO02-1090	70	40	192	100	20	120	12	129	48	4 x 9	M8
NO12, NO14	27	70	260	140	27	167	30	158	63	4 x 14	M12
NO16	27	70	303	140	27	167	30	158	63	4 x 14	M12
NO22	36	120	284	190	36	226	45	220	101	4 x 18	M16
NO24, NO26	36	120	380	190	36	226	45	220	101	4 x 18	M16
NO28	36	120	402	190	36	226	45	220	101	4 x 18	M16
NO32	44	150	358	210	44	254	55	248	120	4 x 22	M20
NO34, NO36	44	150	472	210	44	254	55	248	120	4 x 22	M20
NO38	44	150	502	210	44	254	55	248	120	4 x 22	M20
NA32, NA34, NA36	45	240	508	280	55	325	60	313	151	4 x 22	M20
NA44, NA46	50	270	570	300	60	350	60	346	151	4 x 27	M24
NA54, NA56	70	325	730	350	70	420	70	394	200	4 x 35	M33
NA64	70	380	722	420	80	490	90	431	200	4 x 39	M36

Enclosure № 4

type NO, NA FO

type NO02

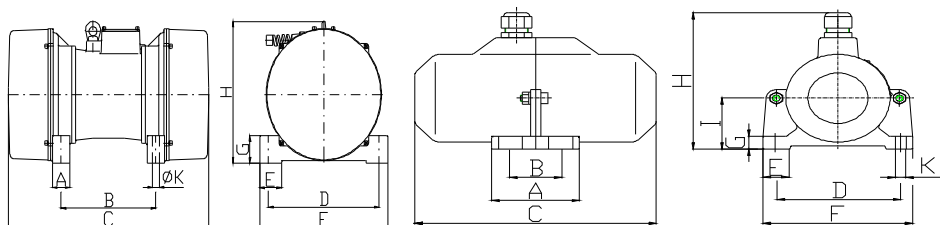

Enclosure № 5

Basic Wiring of one Vibrator

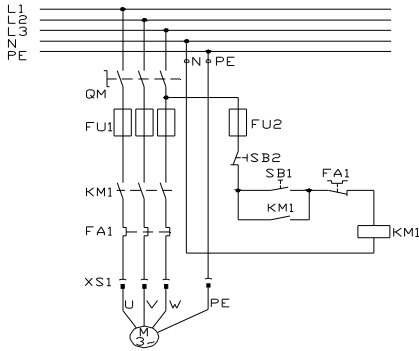

Basic Wiring of two Vibrators

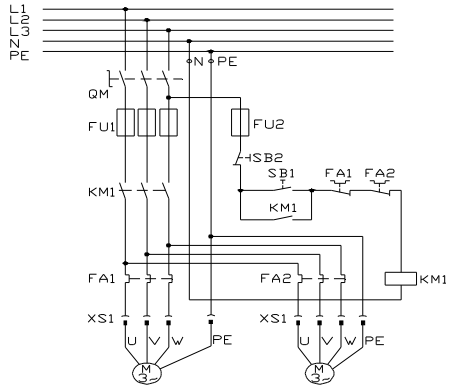

Enclosure № 6

Type vibration:

Undirectional vibration

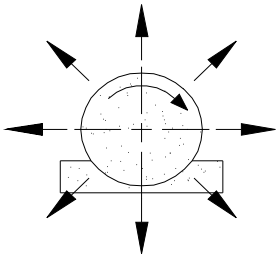

Rotational vibration

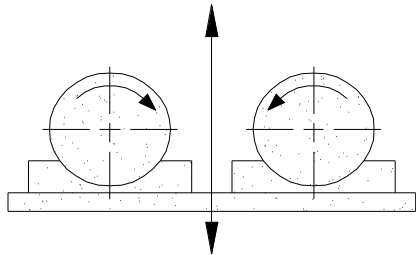

Enclosure № 7

Connection of Terminal Board:

Y-connection to star

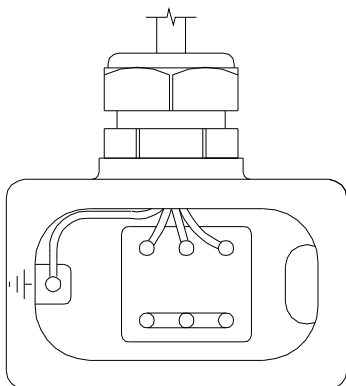

Δ - connection to delta

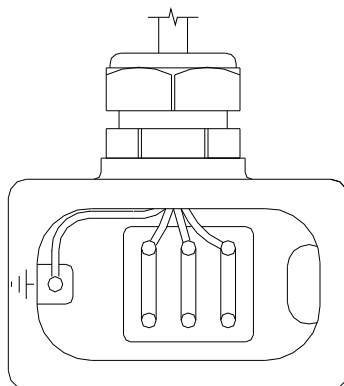

Enclosure № 8

Adjustment counterweights to max.

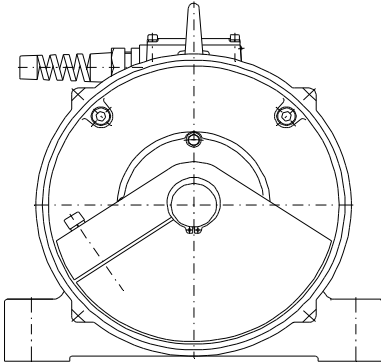

Adjustment counterweights to min.

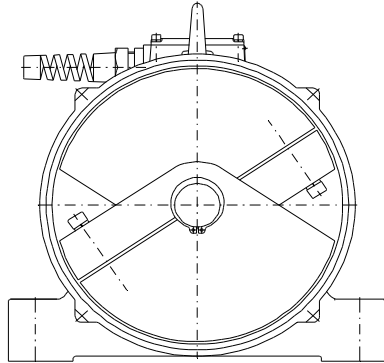

Enclosure № 9

Recommended tighten moments for firmness screw 8G with metric thread

Nominal diameter	Mu [N m]
M6	9,7
M8	24,5
M10	48,4
M12	84
M16	209
M20	406
M24	699
M27	1 038
M30	1 408
M33	1 914
M36	2 456

Rotor (UK) Limited
16 Everitt Close
Denington Industrial Estate
Wellingborough NN82QF

Tel. 01933-230900
Fax 01933-272152
www.rotor.co.uk
info@rotor.co.uk