



INSTRUCTIONS

-J05994

REV. 2015-11-01

LED HEADLAMP KIT

GENERAL

Kit Number

67700241, 67700242, 67700243, 67700244, 67700264, 67700265, 67700266, 67700267

Models

For model fitment information, see the P&A Retail Catalog or the Parts and Accessories section of www.harley-davidson.com (English only).

Installation Requirements

⚠ WARNING

The rider's safety depends upon the correct installation of this kit. Use the appropriate service manual procedures. If the procedure is not within your capabilities or you do not have the correct tools, have a Harley-Davidson dealer perform the installation. Improper installation of this kit could result in death or serious injury. (00333a)

Separate purchase and installation of extra parts or accessories may be required for proper installation of this kit. **2014 and later FLHR, FLHRC and FLHRSE Models** require kit 69200897. **2006-2010 FLHTCUSE Models** require harness jumper 71628-04.

NOTE

This instruction sheet refers to service manual information. A service manual for this year/model motorcycle is required for this installation. One is available from a Harley-Davidson dealer.

Kit Contents

See Figure 5 and Table 1.

REMOVAL

⚠ WARNING

To prevent accidental vehicle start-up, which could cause death or serious injury, disconnect battery cables (negative (-) cable first) before proceeding. (00307a)

⚠ WARNING

Disconnect negative (-) battery cable first. If positive (+) cable should contact ground with negative (-) cable connected, the resulting sparks can cause a battery explosion, which could result in death or serious injury. (00049a)

⚠ WARNING

To prevent accidental vehicle start-up, which could cause death or serious injury, remove main fuse before proceeding. (00251b)

1. See the service manual to remove the main fuse.
2. See the service manual. Follow the instructions to replace the headlamp, removing any trim rings and hardware.
All Models except Touring: Save the hardware, retaining ring and trim ring for installation.
Touring Models: On black version, use the black retainer ring included in the kit.
FL Softail Models: Do not use the black retainer ring included in the kit.
3. **Touring Models:** If motorcycle has a mounting ring: Remove the mounting ring and mounting ring hardware. Discard the mounting ring and headlamp.
4. Disconnect the harness. To remove the headlamp:
 - a. **2006-2010 FLHTCUSE Models:** Unplug cigar lighter and garage door opener to remove existing jumper harness.
 - b. **All other Models:** Remove existing jumper harness.

INSTALLATION

⚠ WARNING

Connect positive (+) battery cable first. If positive (+) cable should contact ground with negative (-) cable connected, the resulting sparks can cause a battery explosion, which could result in death or serious injury. (00068a)

1. If motorcycle has a mounting ring. See the service manual to install the new mounting ring.
2. Connect the harness to headlamp:
Use supplied wire harness to connect to LED headlamp and harness for all **2014 and earlier models**.
 - a. **2014 and later FLHR, FLHRC and FLHRSE Models** require kit 69200897.
 - b. **2006-2010 FLHTCUSE Models:** Use harness jumper 71628-04 to reconnect the cigar lighter, garage door opener and headlamp.
3. See the service manual and follow the instructions to install the headlamp.

WARNING

After installing seat, pull upward on seat to be sure it is locked in position. While riding, a loose seat can shift causing loss of control, which could result in death or serious injury. (00070b)

4. Install seat (if removed) according to the instructions in the service manual.

HEADLAMP ALIGNMENT PROCEDURE

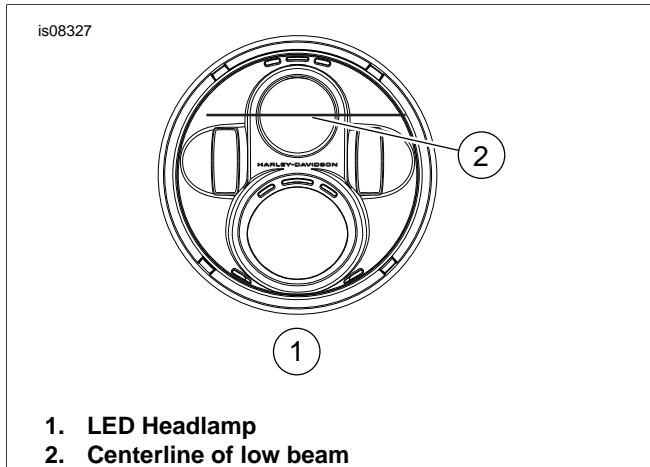

Figure 1. LED Headlamp Configuration

NOTE

The alignment procedure for an LED headlamp is performed on both the **low beam** and the **high beam**. Read these instructions thoroughly to align the LED headlamp.

1. Check tire pressure. See the owner's manual.
2. Fill fuel tank or add an equal amount of ballast.
3. See Figure 2. Position motorcycle so front axle is 25 ft (7.6 meters) (3) from wall.

NOTE

As the weight of the rider compresses the suspension slightly. Have a person weighing roughly the same as the principle rider sit on the motorcycle.

4. See Figure 2. With vehicle laden and upright, point the front wheel straight forward at wall. Measure the distance from the floor to the center of the **low beam** lens (4). Record this measurement.
5. See Figure 1. Draw a horizontal line on the wall at (5) on the wall that is the same measurement as recorded in Step 4.
6. Draw a vertical line (2) off the perpendicular line (1) so it crosses through the horizontal line drawn in the previous step.
7. Verify that all lights are OFF during the alignment procedure.

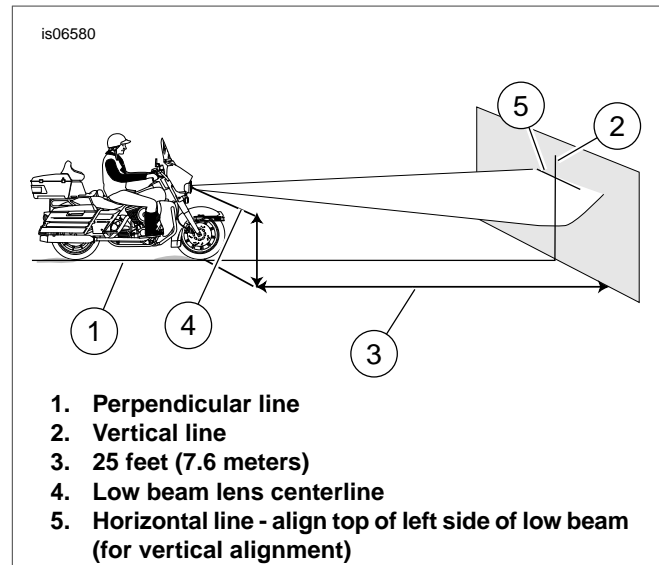

Figure 2. Checking Headlamp Alignment

Alignment of High Beam (Left-to-Right Alignment)

1. Verify that the headlamp lens is perpendicular to the front forks for proper left-to-right alignment.
2. See Figure 3. With vehicle laden and upright, point the front wheel straight forward at wall.
3. Turn on the **high beam** and align the center of the **high beam** hot spot with the intersection of the horizontal and vertical lines (3).

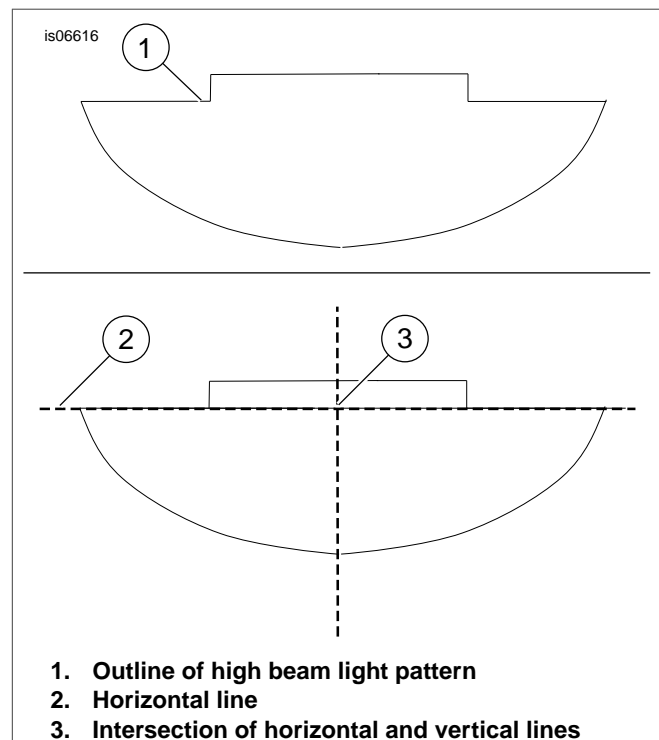

Figure 3. Alignment of Headlamp High Beam

Alignment of Low Beam (Vertical Alignment)

1. See Figure 4. Align the left side of the horizontal line of the **low beam** light pattern (3) with horizontal line (2) drawn on the wall. If necessary, adjust the headlamp position by following the adjustment procedure in the service manual.

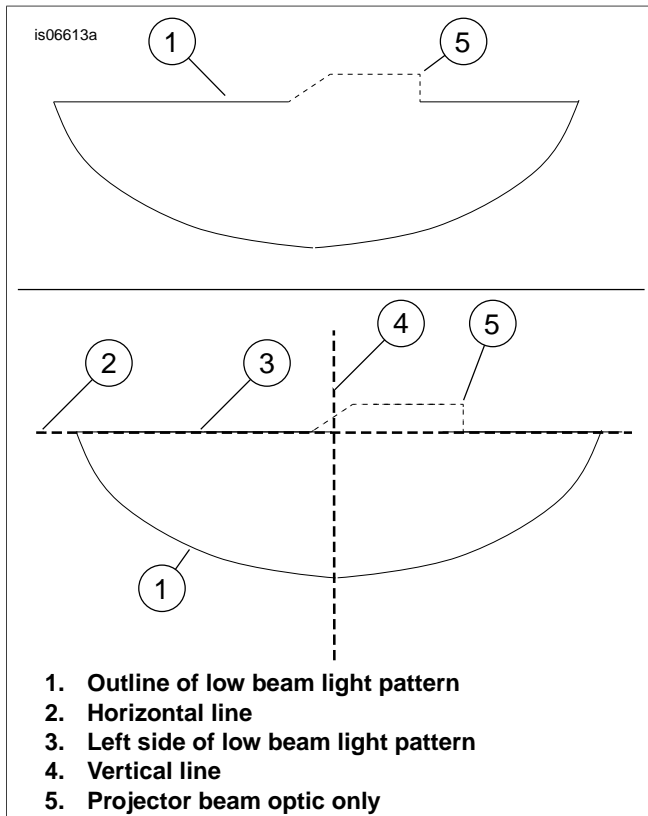

Figure 4. Alignment of Headlamp Low Beam

SERVICE PARTS

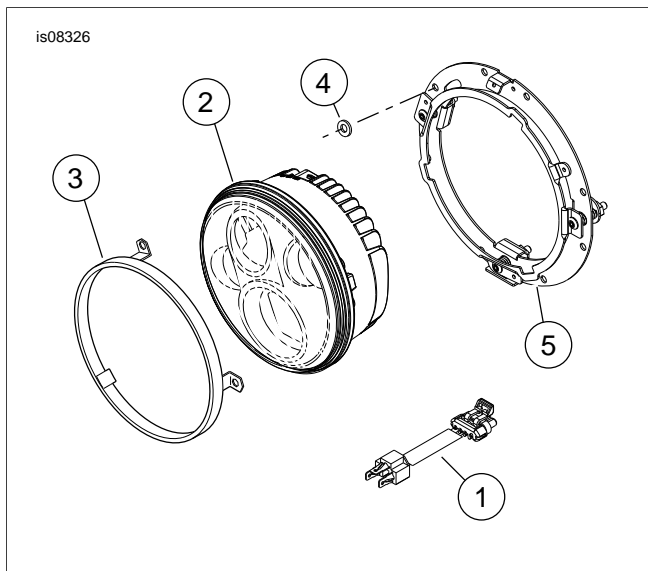

Figure 5. Service Parts: LED Headlamp Kit

Table 1. Service Parts: LED Headlamp Kit

Item	Description (Quantity)	Part Number
Kit Number 67700241		
1	Wire harness, LED headlamp	69201070
2	LED headlamp (chrome)	Not sold separately
Kit Number 67700242		
1	Wire harness, LED headlamp	69201070
2	LED headlamp (black)	Not sold separately
3	Retaining ring (black)	67700068
Kit Number 67700243		
1	Wire harness, LED headlamp	69201070
2	LED headlamp (chrome)	Not sold separately
4	Washer (8)	6717
5	Mounting ring	68124-04B
Kit Number 67700244		
1	Wire harness, LED headlamp	69201070
2	LED headlamp (black)	Not sold separately
3	Retaining ring (black)	67700068
4	Washer (8)	6717
5	Mounting ring	68124-04B
Kit Number 67700264		
1	Wire harness, LED headlamp	69201470
2	LED headlamp (chrome)	Not sold separately
4	Washer (8)	6717
5	Mounting ring	68124-04B
Kit Number 67700265		
1	Wire harness, LED headlamp	69201470
2	LED headlamp (chrome)	Not sold separately
Kit Number 67700266		
1	Wire harness, LED headlamp	69201470
2	LED headlamp (black)	Not sold separately
3	Retaining ring (black)	67700068
4	Washer (8)	6717
5	Mounting ring	68124-04B
Kit Number 67700267		
1	Wire harness, LED headlamp	69201470
2	LED headlamp (black)	Not sold separately
3	Retaining ring (black)	67700068