



INSTRUCTIONS

-J04753

REV. 2009-01-09

CHROME DISPLAY STAND

GENERAL

Kit Number

91573 09

Models

For model fitment information, see the P&A Retail Catalog or the Parts and Accessories section of www.harley-davidson.com (English only).

Additional Parts Required

⚠ WARNING

The rider's safety depends upon the correct installation of this kit. Use the appropriate service manual procedures. If the procedure is not within your capabilities or you do not have the correct tools, have a Harley-Davidson dealer perform the installation. Improper installation of this kit could result in death or serious injury. (00333a)

NOTES

This instruction sheet references service manual information. A service manual for your model motorcycle is required for this installation and is available from a Harley-Davidson Dealer.

Prior to installation of this kit, inspect the frame support bracket flanges for dents or bent areas. If damage is found, contact a Harley-Davidson dealer.

LOCTITE® 271 Threadlocker and Sealant - Red (99671-97) is required to complete this installation and is available from a Harley-Davidson dealer.

Kit Contents

See Figure 2 and Table 1.

INSTALLATION

⚠ WARNING

To prevent accidental vehicle start-up, which could cause death or serious injury, disconnect negative (-) battery cable before proceeding. (00048a)

⚠ WARNING

To prevent accidental vehicle start-up, which could cause death or serious injury, remove main fuse before proceeding. (00251b)

1. Refer to the service manual and disconnect the battery negative (-) cable or remove the main fuse.

NOTE

Make sure that the cutout (B) of the strap (3) is oriented to the rear of the motorcycle after installation.

2. See Figure 2. Install strap (3) and weld nut (4) to the frame in the locations shown.
3. Position the center display stand over the mounting holes under the frame, oriented so that the skid plate faces forward.
4. Apply a small amount of Loctite 271 - Red to the two long screws (1) and secure the rear of the display stand to the frame by installing the two screw to the strap.
5. Apply a small amount of Loctite 271 - Red to the short screw (2) and secure the front of the display stand to the frame by installing the screw to the weld nut.
6. Tighten screws to 60-96 in-lbs (7-11 Nm).
7. Refer to the service manual and connect the battery cables or install the main fuse.

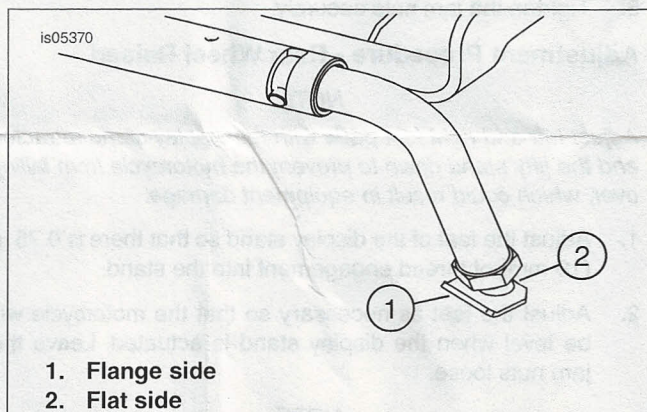

Figure 1. Chrome Display Stand Foot Orientation

ADJUSTING THE DISPLAY STAND

The left and right feet of the display stand are independently adjustable to vertically level the vehicle with the display stand extended. To adjust the display stand:

NOTE

The display stand can be adjusted with rear tire to ground contact or with rear tire off the ground. With the rear tire to ground contact adjustment, the rear wheel is on the ground but enough weight is on the display stand legs to make the motorcycle stable from side-to-side and front-to-back. Using the display stand to center the motorcycle will require effort. With the rear tire off the ground adjustment, the rear tire clears the ground so tire can be rotated for cleaning or maintenance purposes. Using the display stand to lift rear tire off the ground will require more effort.

Do not center the vehicle with someone on the vehicle. To reduce effort, remove stored items from saddlebags, if equipped.

-J04753

1 of 3

Adjustment Procedure - Rear Wheel on Ground

NOTE

Adjust left and right foot pads with the display stand retracted and the jiffy stand down to prevent the motorcycle from falling over, which could result in equipment damage.

1. Adjust the feet of the display stand so that there is 0.75 in (19 mm) of thread engagement into the stand. Verify that the jam nuts remain loose.
2. Engage the stand (See Using the Display Stand), then measure the distance from the bottom of the rear wheel to the ground.
3. Turn the adjuster feet in the distance previously measured.

NOTE

Because the jam nuts are loose, the foot pads should adjust to floor surface.

4. Engage the stand.
5. See Figure 1. Verify that both foot pads and rear wheel are making solid contact with the ground and that the motorcycle is level and stable. Also, verify that the the foot pads are oriented with the flange side (1) facing to the rear and the flat side facing the front (2). If the stand needs additional adjustment, retract the display stand. Adjust foot pads and then engage the stand again. Repeat this step as necessary.
6. Tighten the jam nuts securely.

Adjustment Procedure - Rear Wheel Raised

NOTE

Adjust left and right foot pads with the display stand retracted and the jiffy stand down to prevent the motorcycle from falling over, which could result in equipment damage.

1. Adjust the feet of the display stand so that there is 0.75 in (19 mm) of thread engagement into the stand.
2. Adjust the feet as necessary so that the motorcycle will be level when the display stand is actuated. Leave the jam nuts loose.

NOTE

Because the jam nuts are loose, the foot pads should adjust to floor surface.

3. Engage the stand. (See Using the Display Stand)
4. See Figure 1. Verify that the motorcycle is level and stable. Also, verify that the the foot pads are oriented with the flange side (1) facing to the rear and the flat side facing the front (2). If the stand needs additional adjustment, retract the display stand. Adjust foot pads and then engage the stand again. Repeat this step as necessary.
5. Tighten the jam nuts securely.

USING THE DISPLAY STAND

Engage Display Stand:

WARNING

When using this display stand, do not park on inclined surfaces with the motorcycle front pointing downhill. The vehicle could roll off the stand and fall, resulting in death or serious injury. (00524b)

WARNING

Never start engine when motorcycle is on display stand. Motorcycle could fall resulting in death or serious injury. (00548b)

1. With the vehicle on a level surface, in neutral, jiffy stand down and standing on the left side of the vehicle, lift the left passenger footboard or peg.
2. Hold the left handgrip with your left hand, straighten front wheel and then hold the left rear fender with your right hand.
3. See Figure 2. Place your right foot on the display stand foot lever (A) to lower the display stand foot pads to the floor.
4. Brace your right foot against the foot lever and push lever towards floor surface. Center vehicle on both feet.
5. Once centered on both feet, push down on lever and lift vehicle rearward to ease the vehicle onto the display stand.

Retract Display Stand:

NOTES

The display stand **MUST** not make contact with muffler components or the rear passenger footboard supports. Verify that these components are not making contact with the display stand.

A grease fitting is provided at the rear center of the stand. Lubricate the stand at regular intervals with a good quality grease.

When using a motorcycle lifting device, do not allow motorcycle lifting device to come in contact with the display stand. Damage may occur to display stand.

One can retract the center display stand with the rider on the vehicle or when one is standing next to the left side of the vehicle.

1. With the vehicle in neutral and on a level surface, hold the left handgrip with your left hand and then hold the right hand grip with your right hand covering the front hand brake lever.
2. Push forward (toward the front of motorcycle) on handlebar grips until display stand is retracted. As vehicle comes off display stand, use front brake lever as needed until display stand disengages.
3. Retract the jiffy stand.

SERVICE PARTS

is05960

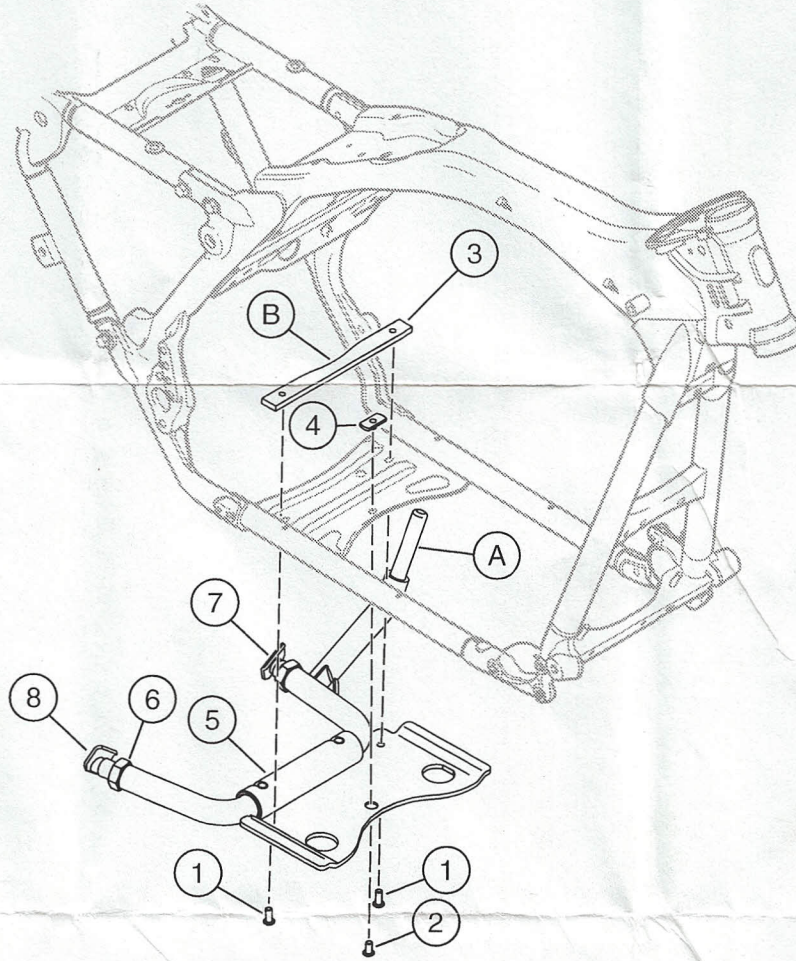

Figure 2. Service Parts for Center Display Stand

Table 1. Service Parts Table

Item	Description (Quantity)	Part Number
1	Screw, long (2)	926
2	Screw, short	3063
3	Strap	91701-09
4	Weld nut	7345
5	Center display stand	Not Sold Separately
6	Jam nut (2)	7855W
7	Assembly, foot, left side	90293-06
8	Assembly, foot, right side	90294-06
Items mentioned in text		
A	Foot lever	
B	Strap cutout	