

**Computer Sports Medicine, Inc., (CSMI)**

**TEF MODULAR COMPONENT**

---

**PARTS & SERVICE MANUAL**

**For HUMAC NORM™ and CYBEX 6000  
Testing & Rehabilitation Systems**

**WARNING**

Service and Repair of the TEF Modular Component should be performed by qualified service personnel only

*Copyright ©2004 Computer Sports Medicine, Inc.  
Stoughton, MA  
All Rights Reserved*

*Disclaimer:*

*CSMI makes no representation or warranties regarding the contents of this manual. We reserve the right to revise this document at any time or to make changes to the product described within it without notice or obligation to notify any person of such revisions or changes.*

**Printed in the United States of America**

Part No.: 20020 Rev: A

## Medical Device Reporting (MDR)

*MDR is intended to provide the Food and Drug Administration (FDA) with the necessary information to assure product safety without imposing an unreasonable burden on device manufacturers and importers.*

*In accordance with FDA regulations, original equipment manufacturers (OEM) and importers of medical devices are required to report to the FDA whenever the OEM or importer receives or becomes aware of information suggesting that one of its marketed devices may have caused or contributed to a death or serious injury. Also, the OEM and importer(s) are required to report to the FDA if one of their devices has malfunctioned, and a recurrence of that malfunction would be likely to cause or contribute to a death or serious injury.*

*An injury is considered "serious" if it is life threatening or results in permanent impairment of a body function or permanent damage to a body structure. A "serious injury" is also defined as an injury requiring medical or surgical intervention to preclude permanent impairment of a body function or permanent damage to a body structure, or to relieve unanticipated temporary impairment of body function or unanticipated temporary damage to a body structure*

*Please contact the CSMI Quality Assurance Department to report any such stated incidence.*

The CSMI NORM™ and TMC Systems are designed to be operated with software that is installed at the time of shipment. Any additional software not authorized by CSMI, that is added to the factory installed program, is done at the user's risk and may cause service problems not covered by the customer's warranty.

The software used to operate either system is protected under copyright laws. Any use of the software other than its intended use with the CSMI 6000 or NORM™ Testing and Rehabilitation System is prohibited. Altering or tampering of the software in any manner constitutes an unwarranted use of the NORM system and immediately voids all warranties expressed or implied by CSMI. CSMI assumes no liability for damaged equipment or harm to any individual as a result of malfunction due to tampered software.

*Trademark Note:*

HUMAC® and NORM™ are registered trademarks of Computer Sports Medicine, Inc.; Microsoft is a trademark and Windows is a trademark of Microsoft Corporation.

## TABLE OF CONTENTS

### SECTION 1: INTRODUCTION

Tef Modular Component.....	1-1
Installation.....	1-1
Part Ordering Information.....	1-1

### SECTION 2: PREVENTIVE MAINTENANCE

Troubleshooting Chart	
Periodic Lubrication.....	2-2
Lubricating Replacement Parts.....	2-2
Linear Actuator Drive Screw and Pivot Rod Lubrication.....	2-2

### SECTION 3: REPAIR PROCEDURES

<b>A</b> Elastic Cord Replacement.....	3-4
<b>B</b> Patient Lift Pivot Replacement.....	3-4
<b>C</b> Footplate Switch Replacement.....	3-6
<b>D</b> Scapula Pad Locking Block Replacement.....	3-7
<b>E</b> Internal Isolation Transformer Fuse Replacement.....	3-8
<b>F</b> External Isolation Transformer Fuse Replacement.....	3-9
<b>G</b> Input Frame Replacement.....	3-10
<b>H</b> Pivot Assembly Replacement.....	3-12
<b>I</b> Rod End Replacement.....	3-12
<b>J</b> Castor Replacement.....	3-13
<b>K</b> Tie Rod Replacement.....	3-14
<b>L</b> Dynamometer Docking Adapter Clamp Wedge Replacement.....	3-16
<b>M</b> Popliteal Pad Locking Lever Spring Replacement.....	3-17
<b>N</b> Countershaft Assembly Replacement.....	3-18
<b>O</b> Pelvic Belt Replacement.....	3-20
<b>P</b> Chest Pad Belt Replacement.....	3-20
<b>Q</b> Gluteal Pad Assembly Pivot Replacement.....	3-20
<b>R</b> Linear Actuator Isolation Pad Replacement.....	3-22
<b>S</b> Linear Actuator Replacement.....	3-22

---

## SECTION 4: PART ORDERING INFORMATION

Part Ordering Information and Procedures .....	4-1
Base Frame Actuator, and Countershaft Assemblies.....	4-2
Top Cover, Input Arm, Pelvic Belt/Buckle, and Input Pivot Assemblies.....	4-4
Scapula Pad and Input Frame Assemblies. ....	4-6
Footplate Carriage, Rear Strut, Docking Adapter Assemblies .....	4-8
Chest Pad, Tie-Rod, Docking Adapter, Popliteal Tube Assemblies.....	4-10
Toggle Clamp, Thigh / Knee and Tibial Pad Assemblies. ....	4-12
Internal Isolation Transformer, Footplate Switch Assemblies .....	4-14
External Isolation Transformer, Footplate Switch Assemblies .....	4-16

## LIST OF FIGURES

### SECTION 3: REPAIR PROCEDURES

Figure 3-1. Elastic Cord and Carriage Cover Replacement.....	3-3
Figure 3-2. Pivot bracket Replacement .....	3-5
Figure 3-3. Internal Isolation Transformer Fuse Replacement.....	3-6
Figure 3-4. External Isolation Transformer Fuse Replacement .....	3-7
Figure 3-5 Input Frame and Pivot Assesmbly Replacement .....	3-8
Figure 3-6.Tie Rod Replacement .....	3-9
Figure 3-7. Docking Adapter Replacement .....	3-11
Figure 3-8. Rod End and Tie Rod Replacement .....	3-14
Figure 3-9. Popliteal Pad Spring Replacement .....	3-16
Figure 3-10 Pelvic Belt and Chest Pad Belt Replacement.....	3-17
Figure 3-11.Linear Actuator Replacement .....	3-18
Figure 3-12.Top Cover Replacement .....	3-21

### SECTION 4: ASSEMBLY ILLUSTRATIONS AND PARTS LIST

Figure 4-1 Base Frame Actuator, and Countershaft Assemblies.....	4-2
Figure 4-2.Top Cover, Input Arm, Pelvic Belt/Buckle, and Input Pivot Assemblies. ....	4-4
Figure 4-3. Scapula Pad and Input Frame Assemblies.....	4-6
Figure 4-4. Footplate Carriage, Rear Strut, Docking Adapter Assemblies .....	4-8
Figure 4-5. Chest Pad, Tie-Rod, Docking Adapter, Popliteal Tube Assemblies.....	4-10
Figure 4-6 Toggle Clamp, Thigh / Knee and Tibial Pad Assemblies.....	4-12
Figure 4-7. Internal Isolation Transformer, Footplate Switch Assemblies.....	4-14
Figure 4-8 External Isolation Transformer, Footplate Switch Assemblies.....	4-16

## IMPORTANT INFORMATION

### Qualified Personnel Notice

**WARNING:** The TMC System contains no user serviceable parts. Installation, Assembly and Repair of the TMC should only be performed by qualified service personnel.

### Classification Information

- The TMC is MET Labs Listed and CE Certified.
- The TMC has been classified for use in accordance with the following sections of the Standards for Medical Electrical Equipment:
  - IEC 60601-1 (1988), 'Medical Electrical Equipment, Part 1: General Requirements for Safety' + A1(91) + A2(95).
  - EN 60601-1 (1990), 'Medical Electrical Equipment, Part 1: General Requirements for Safety' + A1(93) + A2(95) UL 60601-1 (2003), 'Medical Electrical Equipment, Part 1: General Requirements for Safety'.
  - CAN/CSA C22.2 No 601.1-M90 (1990), 'Medical Electrical Equipment, Part 1: General Requirements for Safety'.
  - IEC 60601-1-1 (2000), 2nd Edition, 'Medical Electrical Equipment Part 1: General Requirements for Safety - Collateral Standard: Safety Requirements for Medical Electrical Systems'.
  - CB Scheme.
- The TMC System is rated as Class I, Type B as indicated by the  icon located on the Transformer box rating label.

### Cleaning and Maintenance

**CAUTION:** Do not use Benzene, thinner, or any volatile substance to clean the unit as they may leave a permanent mark. Never leave the unit in contact with rubber or vinyl for an extended period.

- Mechanical parts which contact the patient that appear rusted or can not be cleaned should be replaced.
- Clean/Sterilize removable mechanical parts only.

Upholstery: Use a cloth dampened with a mild household cleaner after each use.

Straps: The belts used on the TMC absorb large and repetitive loads. To ensure patient safety, it is important to check regularly for signs of wear. Any belt with significant wear should be immediately replaced. Keeping extra shin pads and stabilization belts on hand ensures timely replacement and avoids possible injury or down-time.

- The Calibration procedure should be run once per month to assure accurate measurements.
- The user is responsible for disposal of any TMC components per local regulations.

### Assembly and Installation Notes

- The TMC System can be installed in any Ordinary Location.
- The system should be installed in such a way that the User is able to carry out the necessary cleaning, and where applicable the sterilization and disinfection measures as specified in this document.
- Do not attempt to lift the TMC System.

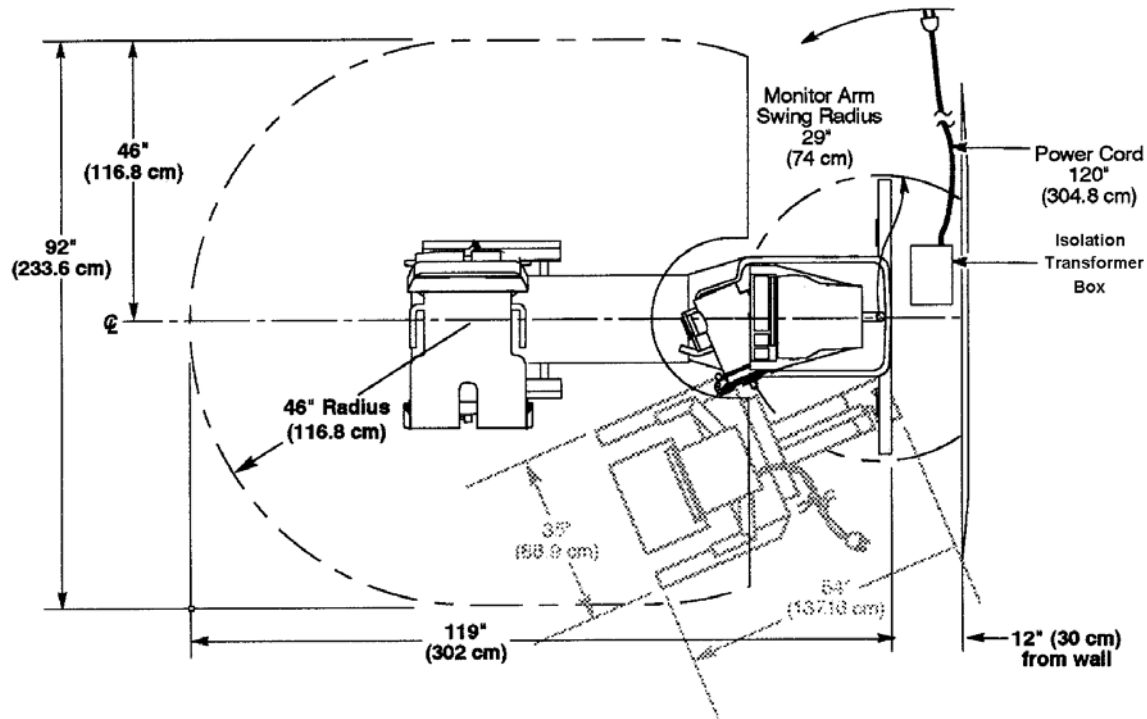

Figure 0-1 TMC Floorplan

### Ratings

- The TMC System is not intended for use in the presence of flammable anesthetics.
- The TMC System is rated for Continuous Operation.
- Operating Temperature 10° Centigrade to 35° Centigrade.
- Storage Temperature -10° Centigrade to 55° Centigrade.
- Operating Relative Humidity 20% noncondensing to 80% noncondensing.
- Storage Relative Humidity 20% noncondensing to 80% noncondensing.
- Special cooling is not required for the operation of the TMC.

**Note:** It is not recommended that the TMC be changed in any way. If any changes are made, adherence to the CE standards becomes the owner's responsibility, if you have any questions, please contact the CSMI Customer Services Department at: (Voice) 781-297-2034 or (FAX) 781-297-2039 or (e-mail) [service@csmisolutions.com](mailto:service@csmisolutions.com).

### Electrical Connections Notes



- The TMC can be wired for 100 VAC, 110 VAC or 220 VAC.
- The following ratings apply for 100 VAC:
  - 100V ~
  - 1Ø
  - 50/60 Hz
  - 3A
- The following ratings apply for 110 VAC:





110V ~  
 1∅  
 50/60 Hz  
 2.5A

- The following ratings apply for 220 VAC:

220V ~  
 1∅  
 50/60 Hz  
 1.5A

- Any changes made to the transformer configuration must be done by a qualified technician.

### Labels

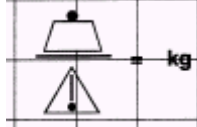
Symbol	IEC Publication	Description
	417-5032	Alternating Current
	417-5019	Protective earth (ground)
	348	Attention, consult accompanying documents
	417-...878-02-02	Type B applied part
	60601-2-38	Weight Limits on support parts

---

## IMPORTANT PRE-USE CONSIDERATIONS

### *Read carefully BEFORE operating the NORM and TMC Systems*

The HUMAC®/NORM™ and TMC Testing and Rehabilitation Systems provide a wide variety of choices for overall treatment of your patients. The NORM is a dynamic system - adhere to the following precautions and instructions to ensure optimum patient safety and proper system usage. DO NOT operate the system until you fully understand its operation and have either:

- attended the in-service provided as a service by CSMI, or
- fully read and understand the documentation provided with the system.

**Note:** Federal law restricts the use of this device to, or on the order of, a licensed physician or licensed practitioner. If you have any questions, please call the CSMI Technical Services Department at: 1-781-297-2034.

### *When using the NORM System, It is the operator's responsibility to:*

- take the time to properly instruct all patients especially those who have difficulty following and carrying out instructions. It is highly recommended that such patients be continually coached and verbally guided throughout the session;
- closely monitor all patients using the system;
- ensure that the computer range of motion stops are always used, and that the mechanical range limiting stops are set to the position indicated by the software. The clinician must ensure that the mechanical range of motion stops are securely set to a maximum safe range for the individual patient, regardless of the operating mode selected.

**WARNING:** *Failure to operate the system without properly positioning the computer and mechanical range limiting stops prior to use may place the patient at risk and/or damage the system.*

- ensure that the Patient Comfort Switch's purpose is clearly explained to the patient and that it is handed to the patient prior to the performance of an activity. The switch is used to stop the input arm from moving when the patient determines that the speed or force has become excessive.
- ensure that the System's input adapter is tightened prior to the patient beginning an activity.  
**CAUTION:** *Failure to tighten the input adapter could result in improper positioning for the pattern.*
- follow the instructions on the screen at all times. During power-up, care must be taken not to place any torque on the input arm as instructed.
- place the system back at the main HUMAC screen at the end of a session and leave it in the setup mode of operation.
- Lock the input arm whenever the system is not in use and when placing patients on or off the system to prevent any inadvertent contact with the input arm.



*(This page intentionally left blank.)*



## INTRODUCTION

---

### TEF MODULAR COMPONENT

The TEF Modular Component is designed to test and rehabilitate the trunk musculature involved in daily lifting, carrying and reaching, as well as posture and movement. Upon docking, the unit becomes an integral part of the CSMI Testing and Rehabilitation System.

CSMI HUMAC application software is used for all back testing and exercise sessions. Detailed information on using this software can be found in the User's Manual of the respective system.

To help the clinician quantify trunk strength deficits, the TEF Modular Component combines safe, totally accommodating resistance with comfortable, secure stabilization. Scapular and chest pads provide upper body stabilization and are the cushions against which the patient flexes and extends.

The lower body is completely stabilized in a slightly bent-knee position by tibial, popliteal and thigh pads, and a pelvic belt. Starting posture for testing and exercising is located at *biomechanically-derived* anatomical zero. This positioning and stabilization ensure safety, and can be accurately reproduced.

Before placing a patient on the TEF Modular Component, the clinician should make sure that it is securely docked to the Testing and Rehabilitation System and that no parts of the unit bind when the input arm assembly is manually moved through the range of motion. The clinician should also be familiar with the clinical aspects of back testing and exercising as well as the CSMI HUMAC Application and Patient Set-up procedure.

### INSTALLATION

Prior to installing the TEF Modular Component, read through the Assembly & Installation Manual to become familiar with the procedures. Read each procedure completely, and follow the steps in order.

The TEF Modular Component is designed to be used with either the CSMI/CYBEX NORM or the CYBEX 6000 Testing and Rehabilitation Systems. For those TEF units currently being used with a CYBEX 6000, an Interface Adapter Kit (P/N 7700K535) is available to convert it for use with a NORM System.

Recommended system floor plan requirements, physical dimensions and special delivery instructions for the TEF Modular Component are outlined in the Assembly & Installation Manual.

If you encounter any difficulty with the installation procedure, have a problem with the unit or would like to order an Interface Adapter Kit call CSMI Customer Service at 781-297-2034. Refer to the CSMI Warranty and Service Policy for explanations of coverage.

### PART ORDERING INFORMATION

Procedures for part ordering and detailed illustrations of each assembly are located in Section 4 of this Manual. The following manuals are available for the NORM System and TEF Modular Component:

NORM User's Guide

- P/N 7700D0000B

NORM Service & Parts Manual

- P/N 7700D6000

NORM Assembly & Installation Manual

- P/N 7700D4000B

TEF Modular Component Service & Parts Manual

- P/N 7310D4004B

TEF Modular Comp. Assembly & Install Manual

- P/N 7310D4000B

TEF Modular Comp. Interface Kit Instructions

- P/N 7310D4005

---

*(This page intentionally left blank.)*

# 2

## PREVENTIVE MAINTENANCE

PROBLEM	POSSIBLE CAUSE	REPAIR PROCEDURE
<b>Patient lift (linear actuator) motor does not function.</b>	Unit is not plugged in.	Verify that the unit is plugged in. Plug in if necessary.
	Fuse is faulty.	For units manufactured prior to 1997, perform procedure (E), <b>Internal Isolation Transformer Fuse Replacement</b> . For units manufactured in 1997 and subsequently, perform procedure (F), <b>External Isolation Transformer Fuse Replacement</b> .
	Patient lift motor is faulty.	Unplug the unit. Remove the back panel. With a 1/4" wrench, remove the two screws securing the linear actuator motor cover. Plug the unit in. With a voltmeter, check that voltage is present at the two motor power wires. If voltage is not present, remove the footplate switch (refer to procedure (C), <b>Footplate Switch Replacement</b> ) and check for voltage. If voltage is present, replace the footplate switch. If no voltage is present, check the power cord and wiring harness to the switch for continuity. Replace as necessary. If power cord, harness and switch are OK, check the continuity of the harness from the switch to the motor and replace as necessary.
<b>Patient lift (linear actuator) is noisy.</b>	Linear actuator isolation pad has failed.	Perform procedure (R), <b>Linear Actuator Isolation Pad Replacement</b> .
	Patient lift assembly is failing.	Perform procedure (S), <b>Linear Actuator Replacement</b> .
<b>Popliteal pad feels heavy.</b>	Elastic cord has failed.	Perform procedure (A), <b>Elastic Cord Replacement</b> .
<b>Popliteal pad locking lever does not lock popliteal pad.</b>	Locking lever spring has failed.	Perform procedure (M) <b>Popliteal Pad Locking Lever Spring Replacement</b> .
<b>Input arm assembly appears to be binding.</b>	Installation adjustment is incorrect.	Refer to TMC Installation manual to realign the TEF Modular Component.
	Pivot assemblies, counter-shaft or rod end are binding.	With a 3/8" Allen wrench, disconnect the rod ends from the pivot assemblies. Isolate the binding assembly and replace it.
<b>Scapula pad locking handle will not lock.</b>	Locking handle block is stripped.	Perform procedure (D), <b>Scapula Pad Locking Block Replacement</b> .
<b>Dynamometer docking adapter will not fit into dynamometer input tube.</b>	Dynamometer docking adapter wedge is bent.	Perform procedure (L), <b>Dynamometer Docking Adapter Wedge Replacement</b> .

## PREVENTIVE MAINTENANCE

---

### PERIODIC LUBRICATION

The TEF MODULAR COMPONENT requires NO periodic lubrication.

If the TEF MODULAR COMPONENT seems to be noisy or otherwise in need of lubrication, refer to **LUBRICATING REPLACEMENT PARTS** listed below for lubrication points and lubricant types.

### LUBRICATING REPLACEMENT PARTS

The following parts must be lubricated when installing replacements, but do not generally require regular lubrication:

- Linear Actuator Drive Screw and Pivot Rod (use multi-purpose Lithium grease)

### *Linear Actuator Drive Screw and Pivot Rod Lubrication*

If it is necessary to lubricate the linear actuator drive screw at times other than replacement, use the following procedure:

1. With a Phillips screwdriver, remove the six screws securing the back panel.
2. Apply a small amount of multi-purpose lithium grease to the exposed threads of the drive screw.
3. Using the footplate switch, run the footplate through its complete range several times to distribute the grease.
4. Inspect the interior of the unit. Remove any excess grease that may have splattered.
5. Reinstall the back panel.

## REPAIR PROCEDURES

---

### TEF MODULAR COMPONENT

The procedures contained in this section apply to units used with both the NORM and CYBEX 6000 Testing & Rehabilitation Systems. Because of configuration differences, some procedures may apply to one system and not the other. Procedures unique to either system are identified by a note of explanation.

Units produced prior to 1997 were equipped with an Internal Isolation Transformer. Starting in 1997, the isolation transformer is externally mounted. All voltage settings are made at the isolation transformer. Refer to the TEF Modular Component Assembly & Installation Manual for voltage adjustment procedures.

When ordering a replacement part refer to exploded view assembly illustrations and corresponding part numbers in Section 4 of this manual.

**REPLACEMENT PROCEDURES**

<b>PROCEDURE</b>	<b>PAGE</b>
<b>A</b> Elastic Cord Replacement .....	3-4
<b>B</b> Patient Lift Pivot Replacement.....	3-4
<b>C</b> Footplate Switch Replacement .....	3-6
<b>D</b> Scapula Pad Locking Block Replacement .....	3-7
<b>E</b> Internal Isolation Transformer Fuse Replacement.....	3-8
<b>F</b> External Isolation Transformer Fuse Replacement .....	3-9
<b>G</b> Input Frame Replacement .....	3-10
<b>H</b> Pivot Assembly Replacement .....	3-12
<b>I</b> Rod End Replacement .....	3-12
<b>J</b> Castor Replacement .....	3-13
<b>K</b> Tie Rod Replacement .....	3-14
<b>L</b> Dynamometer Docking Adapter Clamp Wedge Replacement.....	3-16
<b>M</b> Popliteal Pad Locking Lever Spring Replacement.....	3-17
<b>N</b> Countershaft Assembly Replacement.....	3-18
<b>O</b> Pelvic Belt Replacement .....	3-20
<b>P</b> Chest Pad Belt Replacement.....	3-20
<b>Q</b> Gluteal Pad Assembly Pivot Replacement .....	3-20
<b>R</b> Linear Actuator Isolation Pad Replacement .....	3-22
<b>S</b> Linear Actuator Replacement .....	3-22

***Note: When ordering a replacement part, refer to exploded view illustrations and corresponding part numbers in Section 4.***



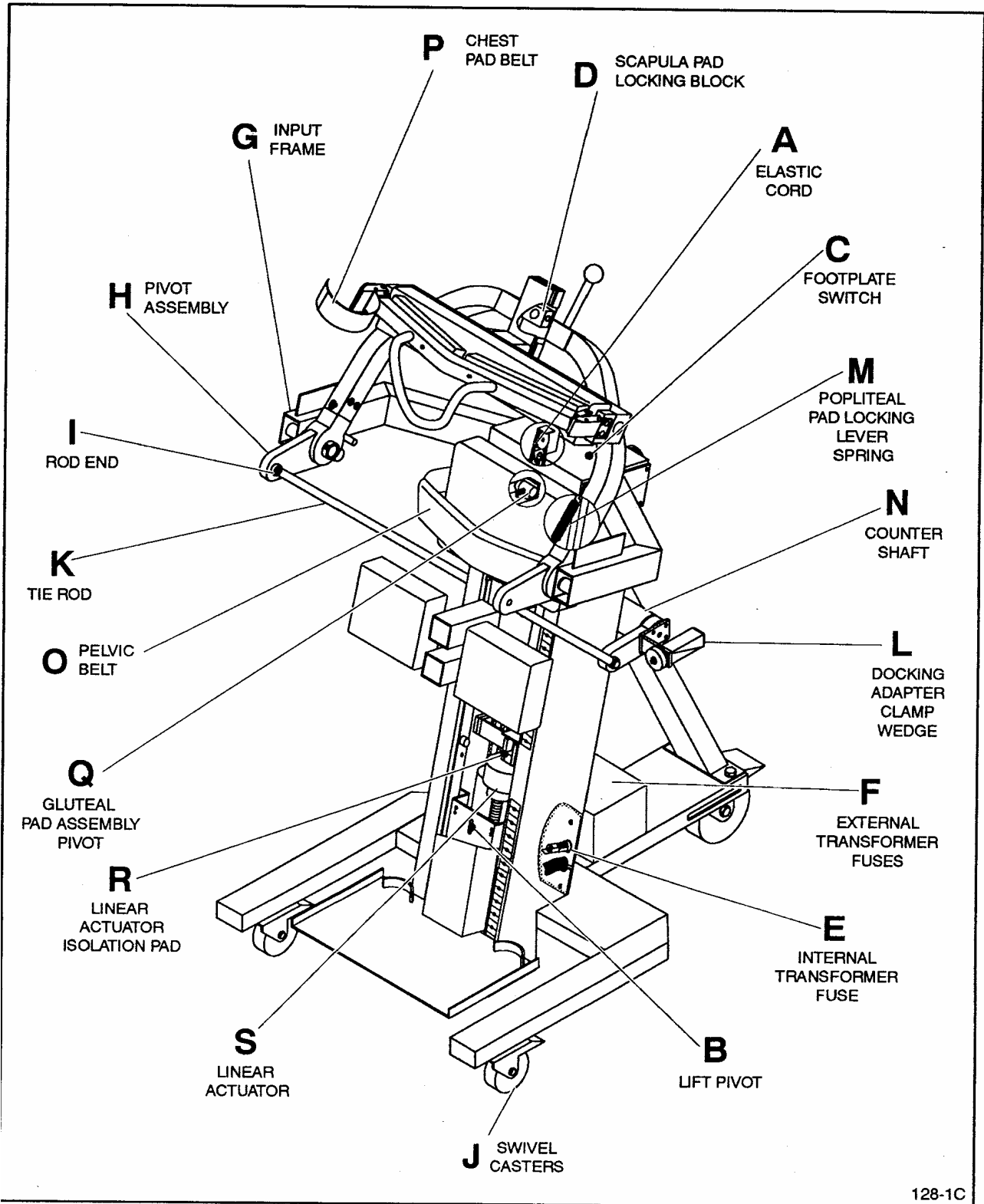

128-1C

Figure 3-1. Trunk Extension / Flexion Modular Component

### A) ELASTIC CORD REPLACEMENT

(P/N PR250001)

#### **Tools Needed**

- Phillips screwdriver
- 5/64" Allen wrench
- 3-foot wire cord or cable (to help guide elastic cord through the frame assembly)

#### **Removal**

1. Unplug the unit from its power source.
2. Remove the gluteal pad by turning the fore/aft alignment wheel clockwise until the pad can be pulled free. Figure 3-2.
3. With a Phillips screwdriver, remove six screws securing the back panel.
4. Perform **Input Frame (G)** Removal Procedure. Figure 3-7.
5. Perform **Tie Rod (K)** Removal Procedure. Figure 3-8.
6. Remove left and right input arms from frame assembly using 9/16" wrench to untighten four hex head cap screws and washers (two per side).
7. Remove top cover from frame assembly and ensure it is supported safely when performing the following steps.
8. Note the routing of the elastic cord. Working through the back of the unit, use a 3-foot wire cord or cable and tie it to elastic cord end attached to popliteal carriage tab. Maintaining wire tension, remove elastic cord end from popliteal carriage. Remove elastic cord from tabs and pulleys. Guide elastic cord through frame assembly and remove it.

#### **Installation**

1. Attach the 3-foot wire cord or cable to the replacement elastic cord.
2. Route one free end of the cord over the lower pulley and attach it to the tab just below the upper pulley.
3. Using the 3-foot wire to guide elastic cord through the frame assembly, route the other free end of the cord over the top pulley and attach it to the tab on the popliteal assembly.
4. Remove 3-foot wire from elastic cord.
5. Reinstall top cover and input arms. Perform **Tie Rod (K)** and **Input Frame (G)** Installation Procedures. Install back panel and gluteal pad.

### B) PATIENT LIFT PIVOT REPLACEMENT (P/N 7310M212)

#### **Tools Needed**

- 9/16" Wrench
- 5/64" Allen Wrench
- Phillips Screwdriver

#### **Removal**

1. Pressing the switch at the top cover, run the footplate to the full down position.
2. Unplug the unit from its power source.
3. With a Phillips screwdriver, remove the six screws securing the back panel. Figure 3-2.
4. With 5/64" Allen wrench, remove four Allen screws securing the footplate carriage cover.
5. With 9/16" wrench, remove the two hex head screws and lockwashers securing the pivot bracket to the footplate. Figure 3-3.

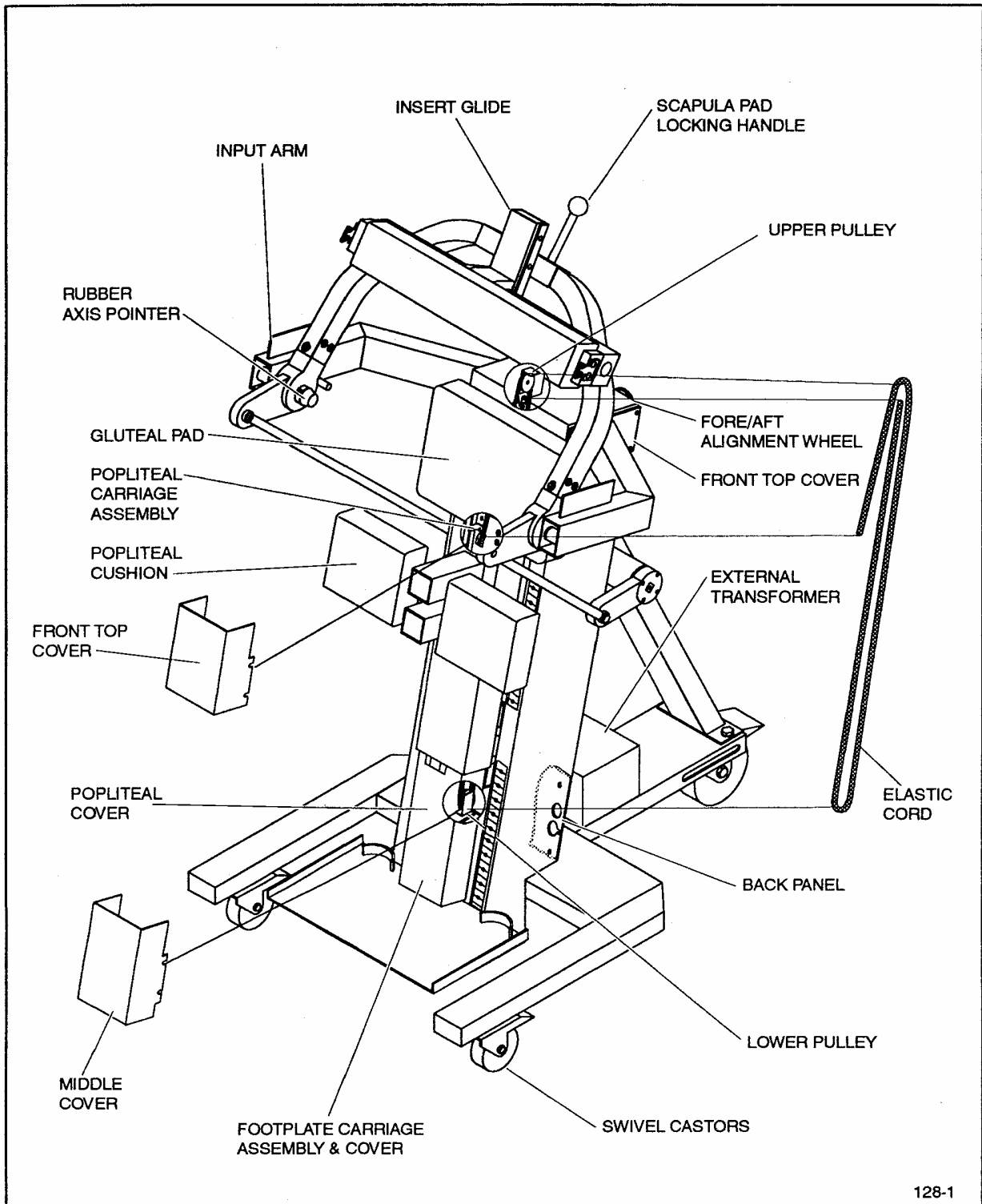

128-1

Figure 3-2. Elastic Cord and Carriage Cover Removal

6. Counting the number of turns, remove the the pivot and bracket from the linear actuator drive screw.
7. Slide the pivot from the bracket

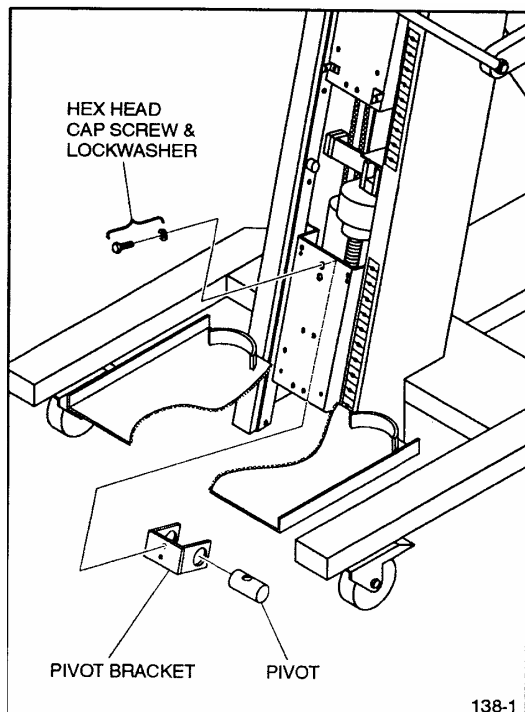

Figure 3—3. Pivot bracket Replacement

### Installation

1. Slide the replacement pivot into the bracket
2. Thread the pivot onto linear actuator drive screw. *Install the pivot onto the screw the same number of turns required to remove the original.*
3. Reinstall the two hex head screws and lockwashers through the footplate and into the bracket and finger tighten

4. Check that the footplate is located at 21 (the dash just below 20 on footplate height scale).
5. If the footplate is properly located, tighten the two screws with a 9/16" wrench.

### NOTE

*If the footplate is not properly located, remove the two screws and turn the pivot on the screw the appropriate direction and number of turns to obtain the proper footplate positioning. Reinstall the two screws and check the position of the footplate. Adjust if necessary. Tighten the \ screws.*

6. Reinstall the footplate carriage cover and back panel.
7. If no other maintenance actions are required, plug unit back into its power source.

## C) FOOTPLATE SWITCH REPLACEMENT (P/N ES110731)

### Tools Needed

- 9/16" Wrench

### Removal

1. Unplug the unit from its power source.
2. Remove the gluteal pad by turning the fore/aft alignment wheel clockwise until the pad can be pulled free. Figure 3-2.
3. Perform **Input Frame (G)** Removal Procedure. Figure 3-7.
4. Remove left and right input arms from frame assembly using 9/16" wrench to untighten four hex head cap screws and washers (two per side).

5. Perform **Tie Rod (K)** Removal Procedure. Figure 3-8.
6. Remove top cover and ensure it is safely supported when performing the following step.
7. Squeeze the footplate switch retainer tabs and slide the switch through top of cover. Figure 3—4.

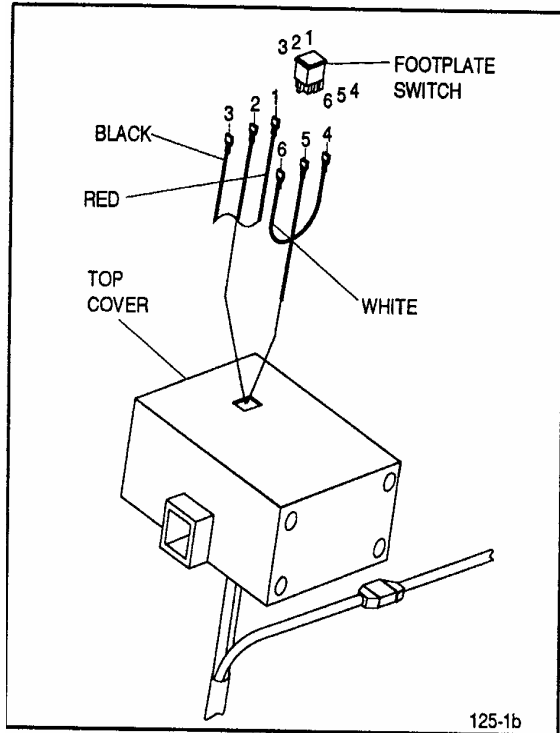

Figure 3—4. Footplate Switch Replacement

**Installation**

1. Remove the wires one at a time and transfer them to the new switch.
2. Slide the switch into top of cover and press into place.
3. Reinstall top cover to frame assembly.
4. Perform **Tie Rod (K)** Installation Procedure. Figure 3-8.
5. Install left and right input arms to frame assembly using 9/16" wrench to secure four hex head cap screws and washers (two per side) to top cover.

6. Perform **Input Frame (G)** Installation Procedure. Figure 3-7. Install gluteal pad.
7. If no other maintenance actions are required, plug unit back into its power source.

**D) SCAPULA PAD LOCKING BLOCK REPLACEMENT** (P/N 7310M682)

**Tools Needed**

- Flat-blade Screwdriver

**Removal and Installation**

1. Unplug the unit from its power source.
2. Move the input arm assembly fully for ward. With a screwdriver, remove the insert glide at the top of the adjusting tube. See Figure 3-7.
3. While holding the scapula pad in position, rotate the scapula pad locking handle counterclockwise, gently pulling it until it is free of the input arm assembly. Slide the scapula pad assembly free.
4. Remove the faulty block and slide the replacement into the tube.
5. Slide the block towards the top of the tube. Insert a pencil or screwdriver through the hole and into the replacement block.
6. Holding the block in place, slide the scapula pad assembly into the input frame assembly so that the pencil is located in line with the locking handle. Insert the locking handle and thread into place turning it clockwise. Hand tighten.
7. Reinstall the insert glide.
8. If no other maintenance actions are required, plug unit back into its power source.

### NOTE

Units manufactured prior to 1997 were equipped with an Internal Isolation Transformer. Starting in 1997, the isolation transformer is externally mounted. To replace fuses in the External Isolation Transformer, refer to procedure (F).

## E) INTERNAL ISOLATION TRANSFORMER FUSE REPLACEMENT (P/N EF290011)

### Items Needed

- Replacement Fuse

### Removal and Installation

1. Unplug the unit from its power source.
2. Locate fuse holder at lower left rear of unit. See Figure 3-5.
3. Push in fuse holder cap and turn counter clockwise. Remove fuse holder cap and fuse.

### CAUTION

Do not substitute different value fuses under any circumstances.

4. Examine the fuse. Look for blackened glass or a broken wire. Replace defective fuses with a type 3AG, 5A, 250V fuses only.
5. Place the fuse into the fuse holder cap. Insert into the fuse holder, press in and turn fuse holder clockwise until it catches, then release.
6. If no other maintenance actions are required, plug unit back into its power source.

7. Press the footplate switch to test the fuse.
9. If the motor does not operate, check the replacement fuse.
  - If the fuse has failed again, unplug unit from its power source and check for an electrical short.
  - If the fuse has not failed, check power source. Check the unit for a faulty footplate switch or linear actuator. Perform replacement procedures for those parts as necessary.

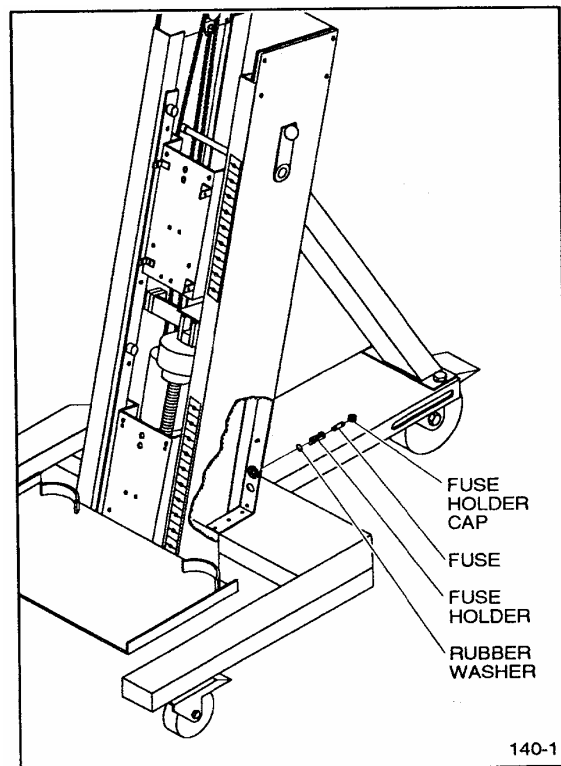

Figure 3-5 Internal Isolation Transformer Fuse Replacement

## F) EXTERNAL ISOLATION TRANSFORMER FUSE REPLACEMENT

(P/N EF000024 for 2.5A Fuse)

(P/N EF290004 for 3.0A Fuse)

(P/N EF000023 for 1.5A Fuse)

### Tools and Items Needed

- 5/16" Phillips Screwdriver
- Flat-blade Screwdriver
- Replacement Fuses

#### NOTE

The External Isolation Transformer is equipped with two fuses. One fuse is panel-mounted and is accessible externally at the back of the unit. The second fuse is base-mounted inside the transformer.

### Panel Fuse Removal and Installation

1. Unplug the unit from its power source.

#### CAUTION

Do not substitute different value fuses under any circumstances.

2. Locate fuseholder above power inlet. See Figure 3-6.
3. Using flat-blade screwdriver, turn fuseholder clockwise and remove it from panel.
4. Remove fuse from fuseholder and inspect it visually. If fuse has blown, replace it with a fuse of equal type and rating.

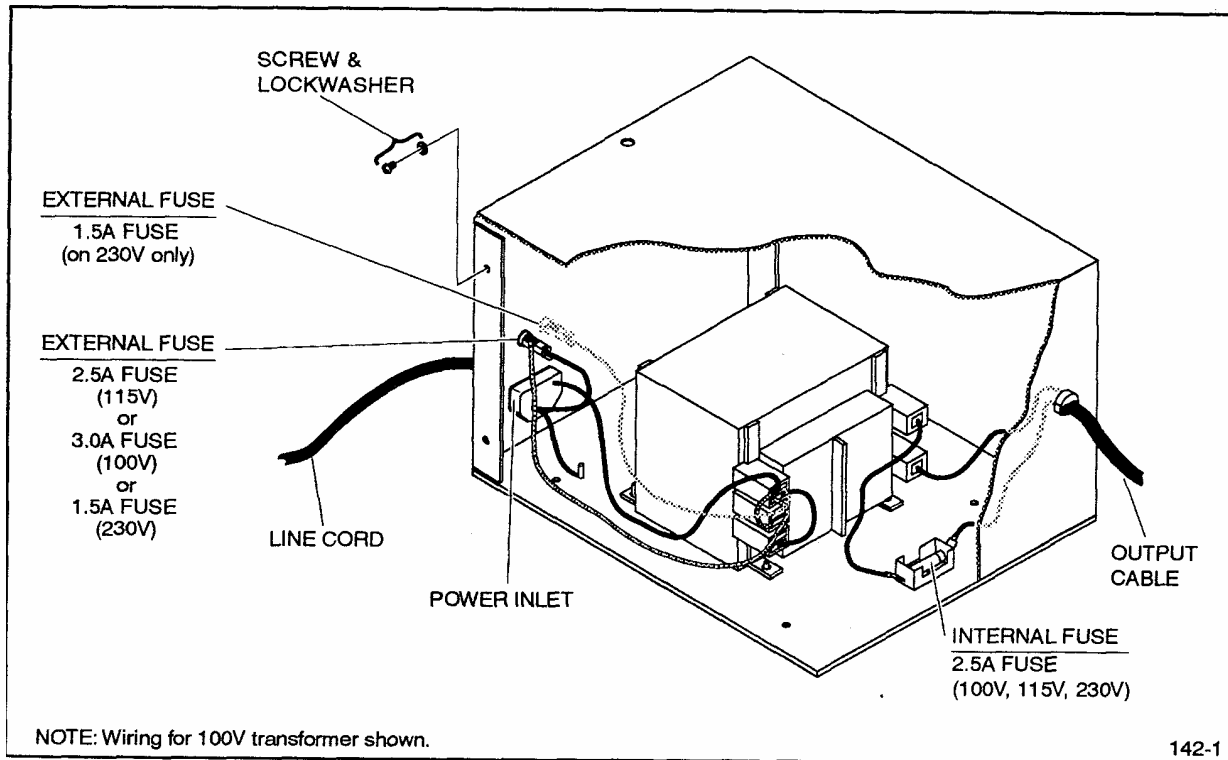

Figure 3-6. External Isolation Transformer Fuse Replacement

5. Insert fuseholder into panel, using flat-blade screwdriver to turn it counter clockwise until it locks into position.
6. If no other maintenance actions are required, plug unit back into its power source.

### **NOTE**

*External Isolation Transformers configured for 230V applications have 2 panel-mounted 1.5A fuses in addition to the 1.5A base-mounted fuse.*

### **Internal Fuse Removal and Installation**

1. Ensure the unit is unplugged from its power source.
2. With 5/16" screwdriver, remove 10 pan head screws and lockwashers securing transformer cover to housing. Remove cover.
3. Locate fuseholder at base of transformer housing, below output cable opening. Figure 3-6.
4. Using fingers, remove fuse from fuseholder and inspect it visually. If fuse has blown, replace it with a fuse of equal type and rating.
5. After replacing the fuse, secure the transformer cover to housing using 5/16" screwdriver to tighten 10 pan head screws and lockwashers.
6. If no other maintenance actions are required, plug unit back into its power source.

## **G) INPUT FRAME REPLACEMENT**

(P/N 7310C640)

### **Tools Needed**

- 1/2" Wrench
- 9/16" Wrench
- Flat-blade Screwdriver

### **Removal**

1. Unplug the unit from its power source.
2. With screwdriver, remove five screw caps at each end of input frame. Figure 3-7.
3. Remove both rubber axis pointers by turning them counterclockwise.
4. With 1/2" wrench, remove six screws and washers from each end of input frame.
5. Remove the input frame from pivot assemblies. Use a rubber mallet if necessary to release the input frame.
6. ***If replacing the input frame only (not the scapula pad)***, remove the scapula pad locking handle by turning it counter clockwise and gently pulling it until it comes free.
7. Slide scapula pad assembly free of input frame.

### **Installation**

1. Slide the input frame onto the pivot assemblies. Align the holes in the input arms with the holes in the pivot assemblies.
2. Reinstall 12 hex head screws (five with screw cap washers and one with bumper cushion on each side) through input frame and into pivot assemblies. Finger tighten.



3. With a 9/16" wrench, gradually tighten each screw one at a time, working from side to side. Repeat until all screws are completely tightened.
4. Move the input frame back and forth through its range of motion. It should be free of any binding. If it is not, loosen the screws and move the arm through its range of motion while adjusting the arm on the pivot assemblies so that there is no further binding. Tighten the screws.
5. Reinstall screw caps at each end of input frame.
6. Reinstall both rubber axis pointers and turn them clockwise until hand tight.
7. **If the scapula pad was removed**, slide the block towards the top of the tube. Insert a pencil or screwdriver through the hole just above the slot and into the replacement block.
8. Holding the block in place, slide the assembly into place. Slide the assembly so that the pencil is located in line with the locking handle. Insert the locking handle and thread into place turning it clockwise. Tighten until hand tight.
9. If no other maintenance actions are required, plug unit back into its power source.

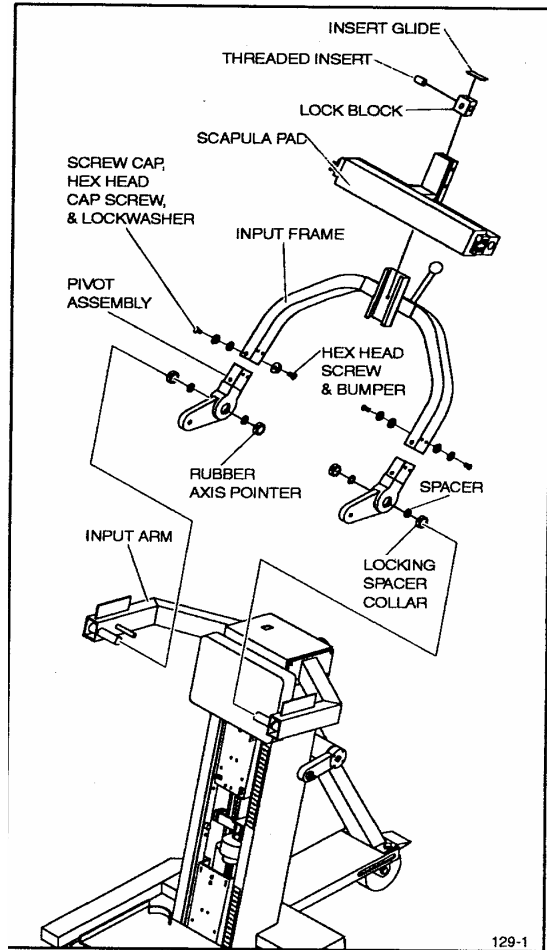

Figure 3-7. Scapula Pad, Input Frame and Pivot Assembly Replacement

## H) PIVOT ASSEMBLY REPLACEMENT

(P/N 7310650)

### Tools Needed

- 3/16" Allen Wrench

### Removal

1. Unplug the unit from its power source.
2. Perform **Input Frame (G)** Removal Procedure. Figure 3-7.
3. Perform **Tie Rod (K)** Removal Procedure. Figure 3-8.
4. Remove both rubber axis pointers by turning them counterclockwise.
5. With a 3/16" Allen wrench, loosen the socket head cap screw in the locking collar securing the pivot assembly. Figure 3-7.
6. Remove the locking collar and the spacer behind it.
7. Remove the pivot assembly.

### Installation

1. Slide the replacement pivot assembly onto the pivot shaft.
2. Slide the spacer and locking collar onto the pivot shaft.
3. With a 3/16" Allen wrench, tighten the socket head screw in the locking collar.
4. Reinstall both rubber axis pointers and turn them clockwise until hand tight.
5. Perform **Tie Rod (K)** Installation Procedure. Figure 3-8.
6. Perform **Input Frame (G)** Installation Procedure. Figure 3-7.
7. If no other maintenance actions are required, plug unit back into its power source.

## I) ROD END REPLACEMENT

(Rear, right hand thread, P/N AP030069, and Front, left hand thread, P/N AP030070)

### Tools Needed

- 3/8" Allen Wrench
- 3/4" Wrench
- Loctite 242

### NOTE

*The following procedure is specific to units manufactured prior to 1997. On later model units, the tie rod is a single, welded part and can be removed using a 3/8" Allen wrench.*

### Removal

1. Unplug the unit from its power source.
2. With a 3/8" Allen wrench, remove the socket head cap screw securing the rod end to the pivot assembly. Figure 3-8.
3. *Note the number of threads on the rod end which are exposed.*
4. With a 3/4" wrench, loosen the rod end locknut.
5. Remove the rod end and locknut.

### Installation

1. Remove the locknut from the rod end and install on the replacement rod end.
2. *Set the locknut to the number of exposed threads noted in step 3 of removal procedure.* Thread the rod end into the tie rod until the locknut rests against the tie rod.
3. Install socket head cap screw through the rod end. Install two washers onto the screw.

4. Thread the screw into the pivot assembly.

**NOTE**

*If the rod cannot be easily threaded into the pivot assembly, loosen the locknut and adjust the length of the assembly by turning the rod end on the tie rod.*

5. With a 3/8" Allen wrench, snug the screw in the rod end.
6. Move the input arm through the full range of motion. Check for binding. If no binding is present, tighten the locknut with a 3/4" wrench. *Be sure to keep both rod ends parallel.*

**NOTE**

*If binding occurs, remove the socket head cap screw securing the rod end. Move the input arm assembly to the range where the binding occurs. Hold the rod end and screw up to the pivot assembly. Adjust the length so that the screw will thread easily. Reinstall the screw and check for binding. Adjust as necessary. Tighten the locknut.*

7. Remove socket head cap screw and apply Loctite 242 to its threads. Thread into pivot assembly and tighten with 3/8" Allen wrench.
8. If no other maintenance actions are required, plug unit back into its power source.

## J) CASTOR REPLACEMENT

(P/N UB021500)

### **Tools Needed**

- Channel-lock Pliers or Adjustable Wrench

### **Removal and Replacement**

1. Unplug the unit from its power source.
2. Lock all three swivel castors. Figure 3–2.
3. Raise and securely prop the leg of unit having the castor to be replaced so that wheel is approximately two inches above the floor.
4. Using channel lock pliers or adjustable wrench, loosen the castor locknut and remove the castor.
5. Place the flat washer from the original wheel onto the replacement. Install the replacement and tighten.
6. Return the unit to the floor.
7. If no other maintenance actions are required, plug unit back into its power source.

## K) TIE ROD REPLACEMENT

(P/N 7310C502)

### Tools Needed

- 3/8" Allen Wrench
- 3/4" Wrench
- Loctite 242

#### NOTE

The following procedure is specific to units manufactured prior to 1997. On later model units, the tie rod is a single, welded part and can be removed and installed using a 3/8" Allen wrench.

### Removal

1. Unplug the unit from its power source.
2. With a 3/8" Allen wrench, remove the socket head cap screw securing the tie rod to the pivot assembly. Figure 3-8.
3. Note the number of threads on the rod ends that are exposed.
4. With a 3/4" wrench, loosen the locknuts for both of the rod ends of the tie rod.
5. Remove the front rod end and locknut.
6. Remove the tie rod from the rear rod end.

#### NOTE

The rear rod end uses a right-hand thread while the front uses a left-hand thread. Loosen accordingly.

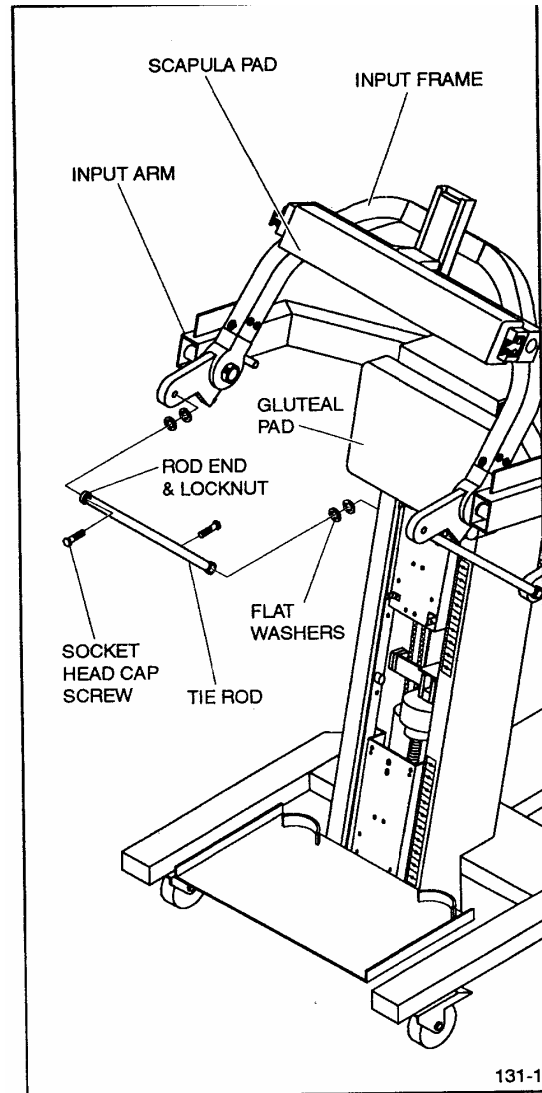

Figure 3-8. Rod End and Tie Rod Replacement

**Installation**

1. Slide the foam off the tie rod and onto the replacement tie rod.
2. Set the locknut for the rear rod end so that the number of exposed threads noted in step 3 is visible. Thread the tie rod onto the rear rod end until the tie rod contacts the locknut. Tighten the rear locknut.
3. Set the locknut for the front rod end so that the number of exposed threads noted in step 3 is visible. Thread the rod end into tie rod until the tie rod contacts the locknut.
4. Install the socket head cap screw through the rod end. Install two washers onto the screw.
5. Thread the screw into the pivot assembly.

**NOTE**

*If the rod cannot be easily threaded into the pivot assembly, loosen the locknut and adjust the length of the assembly by turning the rod end on the tie rod. Thread the screw into the pivot assembly.*

6. With a 3/8" Allen wrench, snug the screw in the rod end.
7. Move the input arm through the full range of motion. Check for binding. If no binding is present, tighten the both locknuts with a 3/4" wrench. *Be sure to keep both rod ends parallel.*

8. Remove the socket head cap screw and apply Loctite 242 to its threads. Thread into the pivot assembly and tighten with a 3/8" Allen wrench.
9. If no other maintenance actions are required, plug unit back into its power source.

**NOTE**

*If binding occurs, remove the socket head cap screw securing the rod end. Move the input arm assembly to the range where the binding occurs. Hold the rod end and screw up to the pivot assembly. Adjust the length so that the screw will thread easily. Reinstall the screw and check for binding. Adjust as necessary. Tighten the locknut.*

**L) DYNAMOMETER DOCKING  
ADAPTER CLAMP WEDGE  
REPLACEMENT** (P/N 7300P785)

**Tools Needed**

- Phillips Screwdriver

**NOTE**

*The following procedure is specific to the dynamometer docking adapters used with CYBEX 6000 systems. On units used with NORM systems, the docking adapter is a single, welded part. There are no subassembly units.*

**Removal and Installation**

1. Unplug the unit from its power source.
2. With a Phillips screwdriver, remove the screw and washer located in the dynamometer docking adapter locking knob. Figure 3-9.
3. Unscrew the locking knob. Remove the thrust washer, clamp wedge and spring from the docking adapter weldment.
4. Remove the spring from the original clamp wedge and install it on the replacement wedge.
5. Install the stud of the replacement clamp wedge through the docking adapter weldment. Install the thrust washer onto the clamp wedge stud. Thread the locking knob onto the stud.
6. Install the screw and washer into the lock stud. Tighten with Phillips screwdriver.
7. If no other maintenance actions are required, plug unit back into its power source.

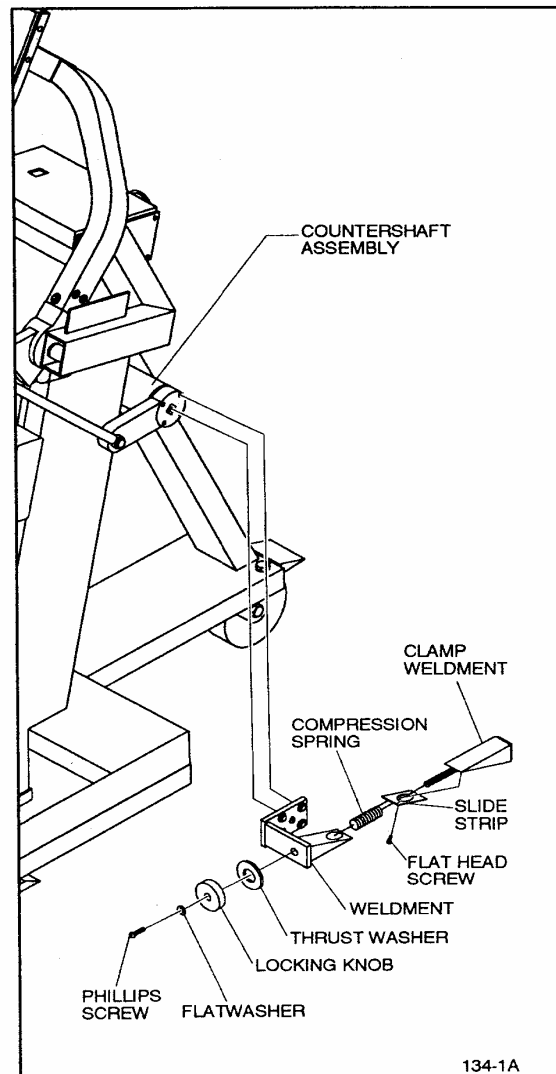

Figure 3-9. Docking Adapter Replacement

**M) POPLITEAL PAD LOCKING LEVER SPRING REPLACEMENT** (P/N BS070731)

**Tools Needed**

- 9/16" Allen Wrench

**Removal**

1. Unplug the unit from its power source.
2. Remove the gluteal pad by turning the fore/aft alignment wheel clockwise until the pad may be pulled free. Figure 3-13.
3. Perform **Input Frame (G)** Removal Procedure. Figure 3-7.
4. Perform **Tie Rod (K)** Removal Procedure. Figure 3-8.
5. Remove left and right input arms from frame assembly using 9/16" wrench to untighten four hex head cap screws and washers (two per side).
6. Remove top cover from frame assembly and ensure it is safely supported in the following step.
7. The spring is located to the right of the opening when looking in through the front of the unit. Remove the spring from the spring roller and then from its mounting tabs. Figure 3-10.

**Installation**

1. Connect the replacement spring to its mounting tabs and loop it over the spring roller.
2. Reinstall top cover.
3. Install left and right input arms to frame assembly using 9/16" wrench to secure four hex head cap screws and washers (two per side) to top cover.

4. Perform **Tie Rod (K)** Installation Procedure. Figure 3-8.
5. Perform **Input Frame (G)** Installation Procedure. Figure 3-7.
6. Reinstall gluteal pad.
7. If no other maintenance actions are required, plug unit back into its power source.

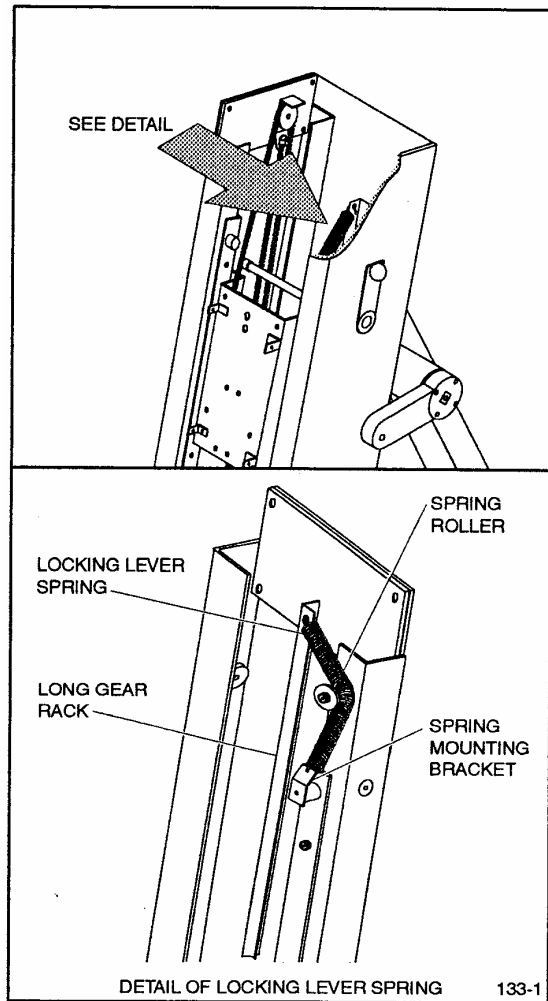

Figure 3-10. Popliteal Pad Spring Replacement

## N) COUNTERSHAFT ASSEMBLY REPLACEMENT

(Countershaft Assembly includes the following parts: Countershaft Housing P/N 7310C733; Countershaft P/N 7310C734; and Countershaft Arms P/N 7310C725)

### CAUTION

*The countershaft assembly is extremely heavy. Two people are needed to perform this procedure. Ensure that the countershaft is properly supported when removing screws.*

### Tools Needed

- 9/16" Wrench
- 3/16" Allen Wrench
- 1/4" Allen Wrench
- 3/8" Allen Wrench
- Loctite 242

### NOTE

*Depending on the maintenance required, it may not be necessary to remove all parts of the countershaft assembly. If the entire countershaft assembly is to be removed, begin the removal procedure at step 5.*

### Removal

1. Unplug the unit from its power source.
2. With a 3/16" Allen wrench, remove flat head cap screws from the left and right countershaft arms (docking adapter and end plate).
3. With a 1/4" Allen wrench, loosen the set screws from left and right countershaft arms.

4. Remove both countershaft arms from the countershaft. Figure 3-11.
5. With a Phillips screwdriver, remove the six screws securing the back panel.
6. Perform **Input Frame (G) Removal Procedure**. Figure 3-7.
7. Perform **Tie Rod (K) Removal Procedure**. Figure 3-8.

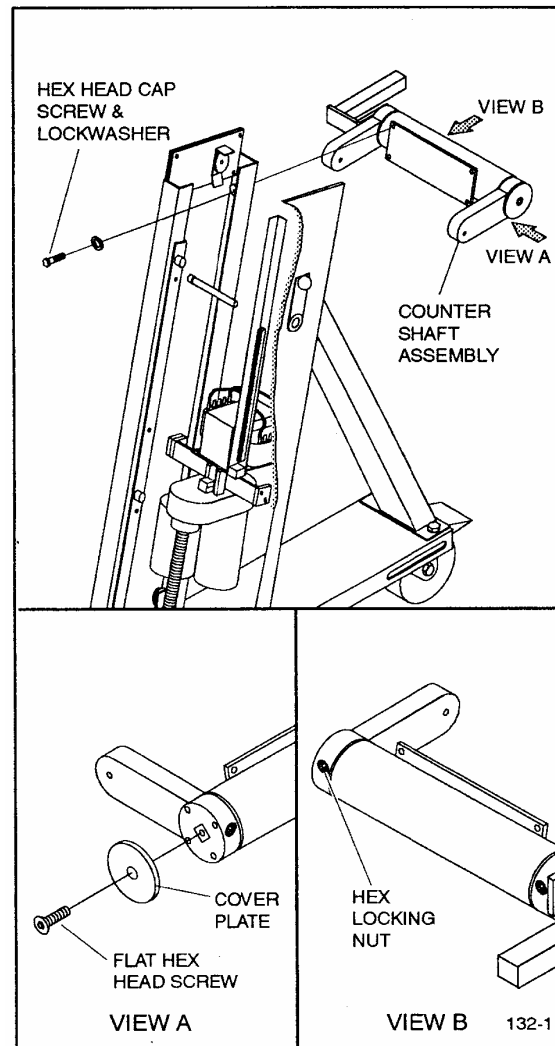

Figure 3-11. Countershaft Assembly Replacement



8. Remove left and right input arms to frame assembly using 9/16" wrench to untighten four hex head cap screws and washers (two per side) to top cover.
9. Remove top cover from frame assembly and ensure it is safely supported.
10. With a 9/16" wrench, remove four screws securing countershaft assembly to rear of unit.

**Installation**

1. Working through top of frame assembly locate screw holes for countershaft assembly.
2. Lift countershaft assembly into position and secure it to TMC frame assembly by tightening four screws and lockwashers using 9/16" wrench.
3. Position both countershaft arms on the countershaft.
4. Reinstall the flat head cap screw from the docking adapter to its original position. Tighten with a 3/16" Allen wrench.
5. Reinstall the flat head cap screw from the end cap through the end cap into the end of countershaft. Tighten with a 3/16" Allen wrench.

6. With a 1/4" Allen wrench, tighten the set screws loosened previously in the countershaft arms.
7. Apply Loctite 242 to the threads of the rod end cap screws. Reinstall screws into countershaft arms. Tighten with a 3/8" Allen wrench.
8. Reinstall top cover.
9. Install left and right input arms to frame assembly using 9/16" wrench to secure four hex head cap screws and washers (two per side) to top cover.
10. Perform **Tie Rod (K)** Installation Procedure. Figure 3-8.
11. Perform **Input Frame (G)** Installation Procedure. Figure 3-7.
12. If no other maintenance actions are required, plug unit back into its power source.

## O) PELVIC BELT REPLACEMENT

(Long Belt w/Buckle, P/N 7310S078; Short Belt w/Release Fitting, P/N 1750S672-10; and Pad, P/N 3400U216-10)

### **Tools Needed**

- 9/16" Wrench (2)

### **Removal and Installation**

1. Unplug the unit from its power source.
2. With a pair of 9/16" wrenches, remove nut securing the right side belt attachment bolt.
3. Remove the bolt from the bracket. The belt will fall free. Figure 3-12.
4. Repeat steps 1 and 2 for the opposite end of the bracket.
5. Remove the pad from the belt and install the buckle on the end of replacement belt.
6. Hold the loop end of the replacement belt open in the mounting bracket and pass the bolt through the bracket and belt.
7. Secure the bolt with the nut removed previously.
8. Repeat steps 5 and 6 for the opposite bracket.
9. If no other maintenance actions are required, plug unit back into its power source.

## P) CHEST PAD BELT REPLACEMENT

(P/N 1750S657-1)

### **Tools Needed**

- External Snap—Ring Pliers

### **Removal and Replacement**

1. Using external snap ring pliers, remove the snap ring and washer from the belt retaining pin. Figure 3-12.
2. Slide the belt retaining pin out so the bottom plastic washer and belt can be removed.
3. Slide replacement belt onto the pin noting the orientation of the buckle. Install the bottom plastic washer.
4. Install the washer and snap ring onto the belt retaining pin.
5. Slide belt retaining pin through the bracket.

## Q) GLUTEAL PAD ASSEMBLY PIVOT REPLACEMENT (P/N 7310M702)

### **Removal and Installation**

1. Unplug the unit from its power source.
2. Remove the gluteal pad by turning the fore/aft alignment wheel clockwise until the pad can be pulled free. Figure 3-13.
3. Slide the pivot from gluteal pad telescoping tube.
4. Install replacement pivot into telescoping tube.
5. Position gluteal pad so that the acme screw can be threaded into the pivot. Turn the alignment wheel clockwise to thread pivot onto screw.
6. If no other maintenance actions are required, plug unit back into its power source.

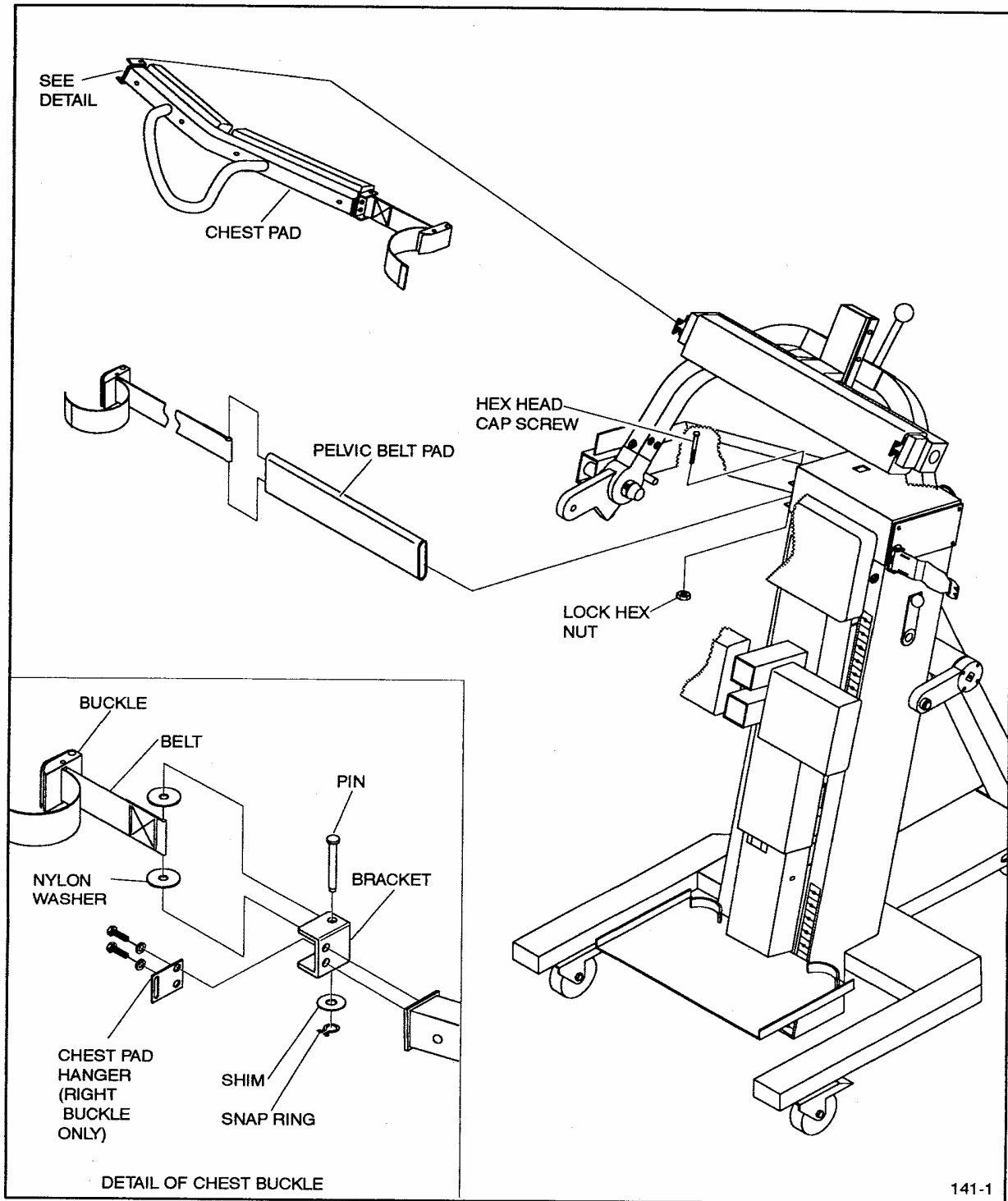

Figure 3-12. Pelvic Belt and Chest Pad Belt Replacement

## R) LINEAR ACTUATOR ISOLATION PAD REPLACEMENT

(P/N 7310M227)

### Tools Needed

- Phillips Screwdriver
- 9/16" Wrench (2)

#### NOTE

*It is very important to secure the linear actuator in place when replacing isolation pads. The position of the actuator's drive screw in relation to the pivot bracket is critical for proper operation of the footplate carriage. Should the actuator slip from its original position, it will be necessary to realign the actuator. Refer to Linear Actuator replacement procedure*

### Removal and Installation

1. Unplug the unit from its power source.
2. With a Phillips screwdriver, remove the six screws securing the back panel.
3. With a pair of 9/16" wrenches, remove the bolt securing the top of the linear actuator. *Note the location of the isolation pads.* Figure 3-13.
4. Reassemble the bolt and replacement isolation pads, securing the actuator to its mount. Tighten the bolt using the 9/16" wrenches.
5. Reinstall the back panel.
6. If no other maintenance actions are required, plug unit back into its power source.

## S) LINEAR ACTUATOR REPLACEMENT

(CE-P/N 7310A900 Rev. A)  
(NON/CE -P/N 7310A900)

### Tools Needed

- 9/16" Wrench (2)
- 5/64" Allen Wrench
- Multi-Purpose Lithium Grease

#### CAUTION

*The following procedure requires significant disassembly and important alignment actions. It should be accomplished in the field only when absolutely necessary. If the assembly has failed completely, begin with step 2 so that the screws to be loosened in step 4 may be accessed.*

### Procedure

1. Run the footplate to the full down position.
2. With a Phillips screwdriver, remove the six screws securing the back panel.
3. With a 5/64" Allen wrench, remove the four Allen screws securing the footplate carriage cover (gray).
4. With a 5/64" Allen wrench, loosen the four screws securing the middle cover. They may be accessed through the space created by the removal of the back panel.
5. Run the footplate to the full up position. *Note the number of threads visible on the drive screw above the pivot.*
6. With a 9/16" wrench, remove the two screws securing the pivot bracket to the footplate. Figure 3-3.

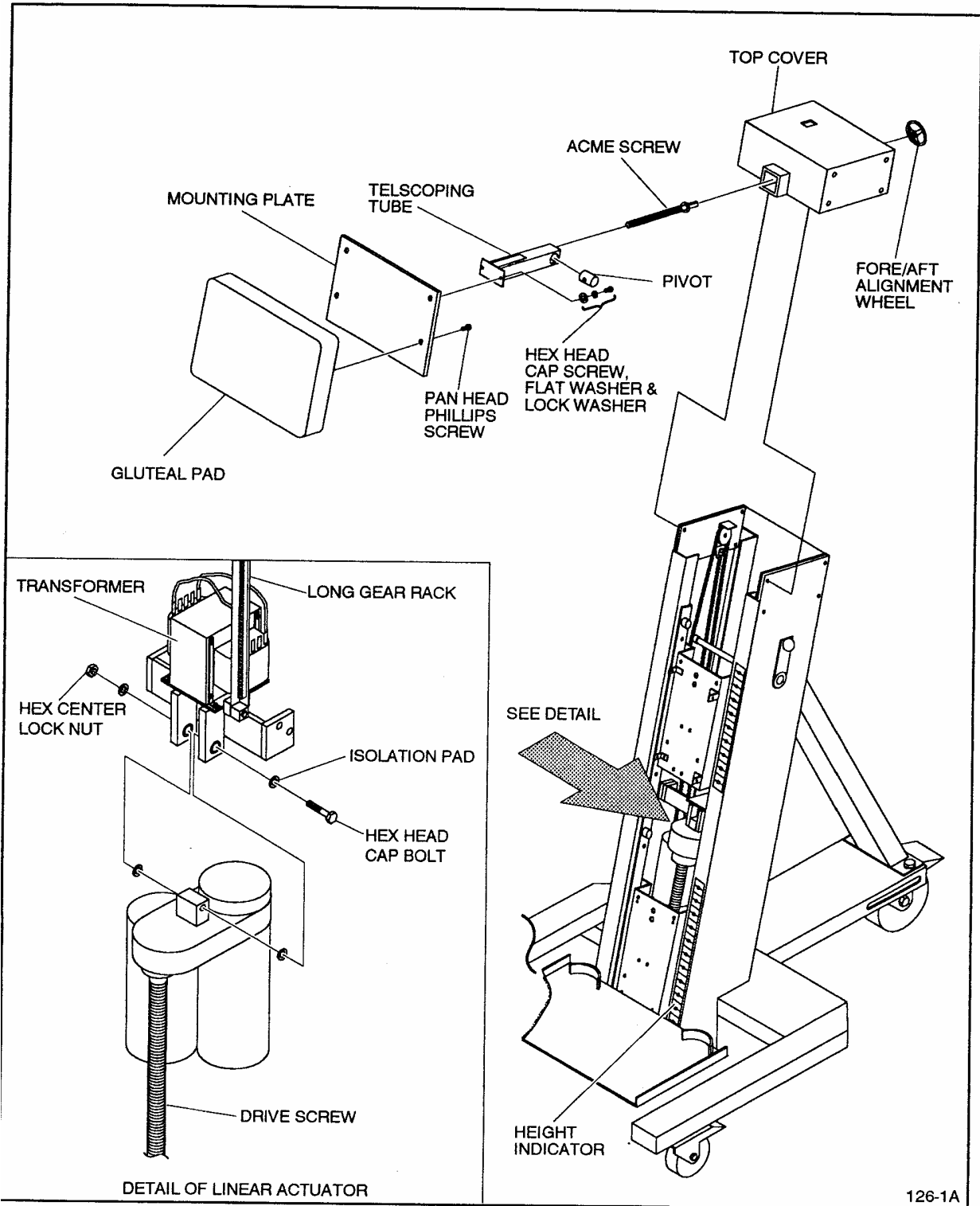

Figure 3-13. Gluteal Pad and Linear Actuator Replacement

## REPAIR PROCEDURES

---

7. Run footplate to the full down position. Remove the pivot and bracket from the drive screw.
8. Unplug the unit from its power source.
9. Squeeze the footplate switch retainer tabs against the body of the switch and slide the switch through the top of the cover. Figure 3-14.
10. Pull the power cord free.
11. With a pair of 9/16" wrenches, remove the bolt securing the top of the linear actuator. *Note the location of isolation pads.* Figure 3-13.
12. Pull the linear actuator and actuator power cord free of the unit.
13. Position the replacement linear actuator in the unit. Reassemble the isolation pads and bolt to secure the linear actuator to its mount. Tighten the bolt.
14. Disconnect green wire from the spade terminal adjacent to switch. Disconnect the red wire from terminal #1. Disconnect the power cord white wire (not the jumper) from terminal #6. Disconnect the black wire from terminal # 3.
15. Remove the ty-wraps holding the actuator power cord to the unit.
16. Route the actuator power cord through the footplate switch opening in the top cover.
17. Connect the top cover wires as follows: green wire to the spade terminal adjacent to the switch; red wire to terminal #1; white wire of the power cord to terminal #6, and black wire to terminal #3. Figure 3-14.
18. Ty-wrap the actuator power cord to the ty-wrap mounts.
19. Reinstall the footplate switch in the top cover.
20. With a 1/4" wrench, remove the cover from the linear actuator motor.
21. With a 1/4" wrench, remove the two screws securing the upper switch cam. Remove cam.
22. Plug the unit into power source.
23. Run the motor to the full up position.
24. Turn the pivot and bracket onto the drive screw as far as possible.
25. *Count the number of threads visible above the pivot. Note the number. From that number subtract the number of threads visible in step 5. The result is the number of turns that the drive screw must be turned clockwise (viewed from above).*

### **NOTE**

*If the original motor failed completely, reinstall the two hex head screws through the footplate and into the pivot bracket and finger tighten. Measure, in inches, the distance between the height indicator and 0. Multiply by 6; this is the number of complete turns that the pivot must be raised on the drive screw. Remove the screws. Turn the drive screw clockwise (viewed from above) the same number of turns noted previously. Turn the pivot onto the drive screw the noted number of turns. Proceed to step 28.*

26. *Turn the pivot and bracket onto the screw the same number of turns. The result should place the pivot and bracket in the same position as step 25.*

27. While holding the pivot and bracket, run the motor to the full up position. The motor should turn off automatically when the same number of threads noted in step 5 are visible.

If the number of visible threads differs, run the motor downward while holding the pivot and bracket until the pivot and bracket are clear of any obstructions. Turn the pivot on the screw to adjust for the difference. Hold the pivot and bracket and again run the motor full up. Re-peat if necessary.

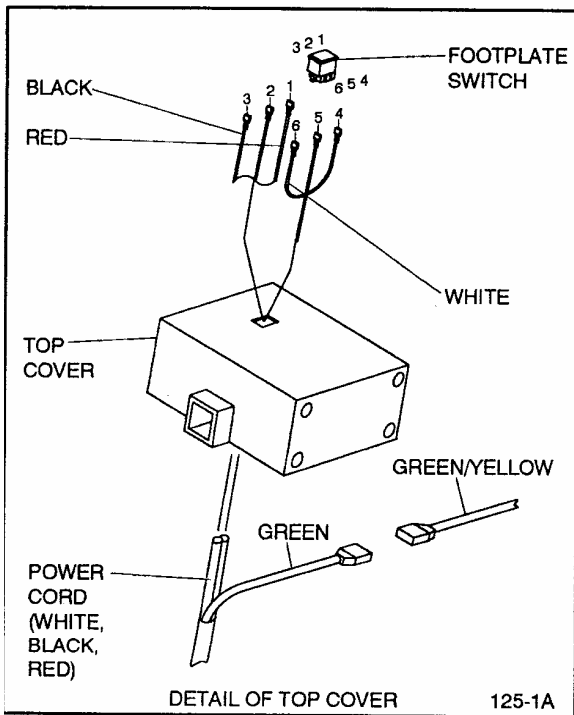

Figure 3-14. Top Cover Wire Replacement

**NOTE**

During the next step, do not allow the pivot to be pulled above the threaded portion of the drive screw.

28. Lift the footplate up to the pivot and bracket. Reinstall the two hex head screws through the footplate and into the

pivot bracket. Finger tighten. The height indicator position should be 0.

If height indicator is not at 0, note the distance between the height indicator and 0. Each half turn of the pivot changes the foot plate height by approximately 1/8". Remove the screws securing the footplate. Run the motor downward while holding the pivot and bracket until the pivot and bracket are clear of any obstructions. Turn the pivot on the screw to adjust. Repeat the step. *Verify that the footplate stops at 0 when the footplate switch is used.*

29. Run the footplate to 21 (the dash below 20) on the height indicator.
30. Reinstall the upper motor switch cam with the lobe rotated slightly clockwise of the switch lever. Rotate the cam counter clockwise until a "click" is heard. Hold the cam in position and tighten the screws.
31. Using the footplate switch verify that the linear actuator stops at the appropriate locations (0 and 21).
32. If both stop locations are correct, reinstall the the motor cover. *If the bottom stop position is not correct, readjust the cam and test. Reinstall the motor cover when stop location is correct.*
- 33 Run the footplate to 21 on the height indicator and apply a small amount of multi-purpose lithium grease to the exposed threads of the drive screw.
34. Using the footplate switch, run the footplate through its complete range several times to distribute the grease. Remove any grease that may have splattered.
- 35 Reinstall the footplate, middle, and back panel covers.



**NOTES**



# 4

## REPLACEMENT PARTS

---

### PART ORDERING INFORMATION

To order parts for the TEF Modular Component, or for technical assistance, contact CSMI Customer Service at 781-297-2034, Customer Service Fax: 781-297-2039, or [www.csmisolutions.com](http://www.csmisolutions.com).

Section 4 includes exploded view drawings of the TEF Modular Component and a complete list of part numbers. When ordering replacement parts refer to the appropriate part number.

#### ***Part ordering procedure***

1. Identify the appropriate part(s) needing replacement in the exploded view drawings.
2. Using the item number on the drawing, locate the corresponding item number on the Parts List to obtain the correct Part Description and Part Number.
3. Please have the following information ready when calling (Your CUSTOMER NUMBER is helpful, but not necessary):
  - a. The unit SERIAL NUMBER.
  - b. The unit NAME.
  - c. The PART DESCRIPTION and the PART NUMBER.
  - d. The FACILITY ADDRESS, PHONE NUMBER and CONTACT NAME

# REPLACEMENT PARTS

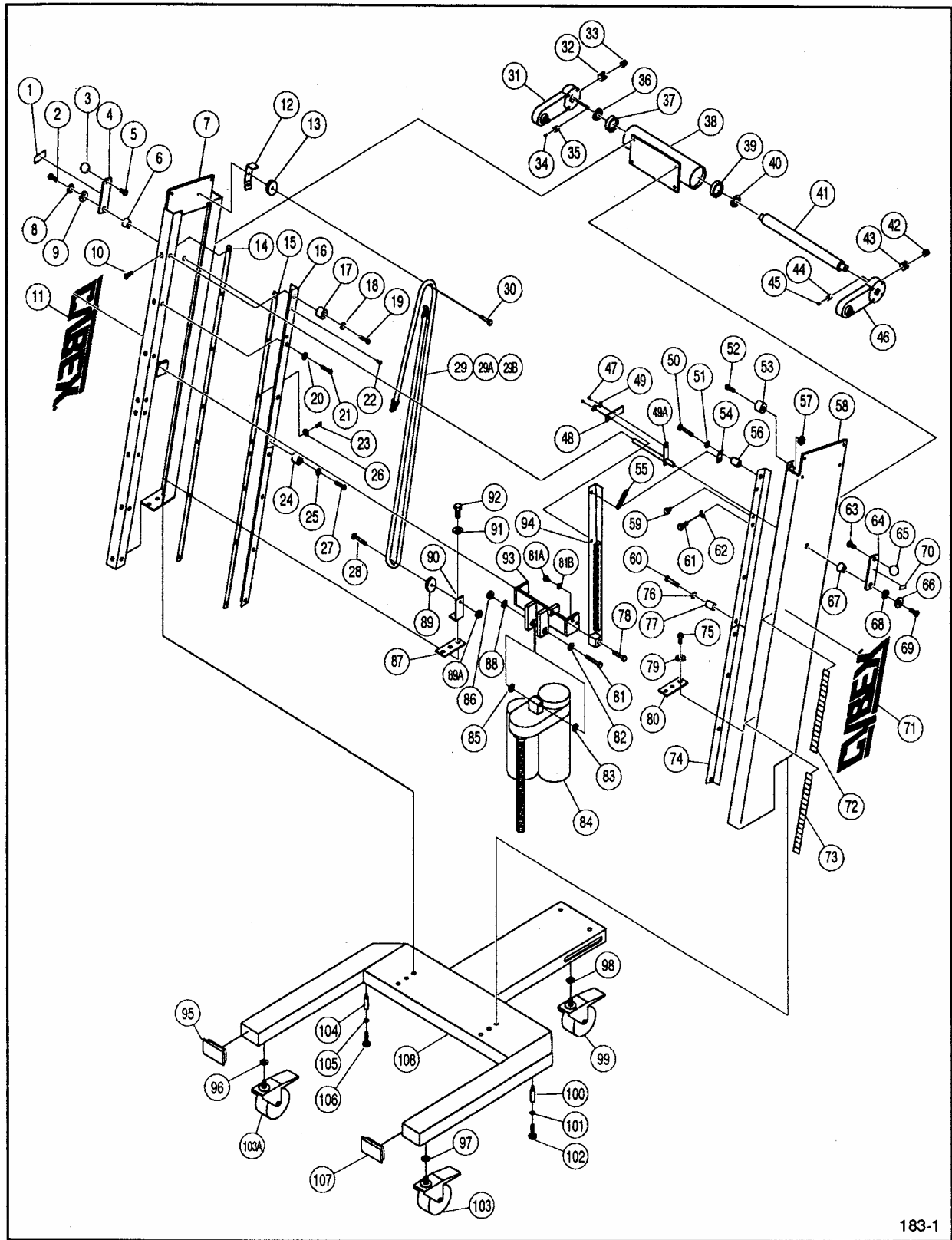

183-1

Figure 4-1 Base Frame Actuator, and outershaft Assemblies.

**REPLACEMENT PARTS**

REF.	DESCRIPTION	PART NO.	REF.	DESCRIPTION	PART NO.
1	Label, Indicator Arrow	730CM018	57	Nut, 10-32UNF Hex Steel	HN584100
2	Screw, 10-32x1/2 Screw Head Cap	HM582812	58	Left Side of Frame Weldment	7310C071
3	Knob	PP460028	59	Screw, Low Soc Head Cap, 8-32x1/4	HC543408
4	Lever (Popliteal)	7310C322	60	Screw, Soc Head Cap, 10-32x1-1/2	HC582822
5	Screw, #8-32x3/8 Hex Soc Flat Head	HM540910	61	Screw, 10-32x1/2 Soc Head Cap	HM582812
6	Bushing	7310M324	62	Lockwasher, #10 Split	HS108302
7	Right Side of Frame Weldment	7310C070	63	Screw, #8-32x3/8 Hex Soc Flat Head	HM540910
8	Lockwasher, #10 Split	HS108302	64	Lever (Popliteal)	7310C322
9	Cap Screw Washer (1/4)	HS010003	65	Knob	PP460028
10	Screw, 10-32x1/2 Soc Flat Head	HM581012	66	Lockwasher, #10 Split	HS108302
11	Label, TMC logo	731CM010	67	Bushing	7310M324
12	Bracket, Wheel	7310M314	68	Cap Screw Washer (1/4)	HS010003
13	Wheel Elastic Cord	7310M305	69	Screw, 10-32x1/2 Soc Head Cap	HM582812
14	Guide, Round Roller	7310M201	70	Label, Arrow Indicator	730CM018
15	Guide, Round Roller	7310M201	71	Label, TMC Logo	7310M010
16	Guide Roller	7310C202	72	Label, Footplate/Popliteal Scale	731CM079
17	Stop, Popliteal	7310M221	73	Label, Footplate/Popliteal Scale	731CM079
18	Lockwasher, #10 Split	HS108302	74	Roller Guide (Roller)	7310C222
19	Screw, Soc Head Cap, 10-32x1-1/2	HC582822	75	1/4-20x3/4 Hx Head Cap Screw	HC621215
20	Lockwasher, #10 Split	HS108302	76	Lockwasher, #10 Split	HS108302
21	Screw, 10-32x1/2 Screw Head Cap	HM582812	77	Stop, Popliteal	7310M221
22	Screw, Low Soc Head Cap, 8-32x1/4	HC543508	78	Bolt, Shoulder, 1/4 x 3/4	HD303315
23	Screw Low Soc Head Cap, 10-32x1/2	HM583412	79	Lockwasher, .4890Dx.255IDx.062T	HS308300
24	Stop, Popliteal	7310M221	80	Spacer Bar	7310M074
25	Lockwasher, #10 Split	HS108302	81	Screw, 3/8-16x3 Hex Head Cap	HC701234
26	Lockwasher, #10 Split	HS108302	81A	Screw, 3/8-16x1 Hex Head Cap	HC701217
27	Screw, Soc Head Cap, 10-32x1-1/2	HC582822	81B	Lockwasher (3/8) .685ODx.391IDx.095T	HS348360
28	Bolt, Shoulder, 1/4x3/4	HD303315	82	Motor Isolation Pad	7310M227
29	Cord, Elastic	PR250001	83	Motor Isolation Pad	7310M227
29A	Terminal Fastener	HF349001	84	Linear Actuator	AG030731
29B	Ring Locking	BR070001	85	Motor Isolation Pad	7310M227
30	Bolt, Shoulder, 1/4x3/4	HD303315	86	Nut, 3/8-16 Hex Center Lock	HN704002
31	Input Arm Weldment	7310C725	87	Spacer Bar	7310M074
32	Helicoil, 1/2-13	BR030073	88	Motor Isolation Pad	7310M227
33	Set Screw, Modified	7300M112	89	Wheel, Elastic Cord	7310M305
34	Screw, Soc Head Cap, 6-32x1/4, Nylok	HC532807	89A	Locknut, 10-24 Hex	HN624400
35	V-Pusher	7300M111	90	Bracket, Wheel	7310M317
36	Spacer, Counter Shaft	7310M747	91	Lockwasher, .4890Dx.255IDx.062T	HS308300
37	Bearing, Radial Ball, 1-1/2 ID	FB030028	92	Screw, 1/4-20x3/4 Hex Head Cap	HC621215
38	Weldment, Counter Shaft Housing	7310C733	93	Weldment, Motor Mtg Bracket	7310C203
39	Bearing, Radial Ball, 1-1/2 ID	FB030028	94	Weldment, Long Gear Rack	7310W310
40	Spacer, Counter Shaft	7310M747	95	Insert Glide, 2x3x11GA. Black	PP120005
41	Counter Shaft	7310M734	96	Flat Washer (1/2) 1-3/80Dx9/16IDx.11T	HS387500
42	Set Screw, Modified	7300M112	97	Flat Washer (1/2) 1-3/80Dx9/16IDx.11T	HS387500
43	Helicoil, 1/2-13	BR030073	98	Flat Washer (1/2) 1-3/80Dx9/16IDx.11T	HS387500
44	V-Pusher	7300M111	99	Wheel	WB21500-'
45	Screw, Soc Head Cap, 6-32x1/4 Nylok	HC532807	100	Standoff, Base Frame	7310C095
46	Input Arm Weldment	7310C725	101	Nut, 1/2-13 Regular Hex Jam	HN784400
47	Screw, 1/4x3/8	HD303310	102	Leveling Glide, 1/2-13	HG780029
48	Link #1, Popliteal	7310M318	103	Wheel	WB21500
49	Spacer	7310M323	103A	Wheel	WB21500
49A	Weldment, Lever Shaft	7310C321	104	Standoff, Base Frame	7310C095
50	Screw, Soc Head Cap, 10-32x1-1/2	HC582822	105	Leveling Glide, 1/2-13	HG780029
51	Lockwasher, #10 Split	HS108302	106	Nut, 1/2-13 Regular Hex Jam	HN784400
52	Screw, Soc Head Cap, 10-32x1-1/2	HC582822	107	Insert Glide, 2x3x11GA. Black	PP120005
53	Roller, Spring	7310M326	108	Weldment, Base Frame	7310C059
54	Bracket, Carriage	7310M315			
55	Spring, Extension	BS070731			
56	Stop, Popliteal	7310M221			

REPLACEMENT PARTS

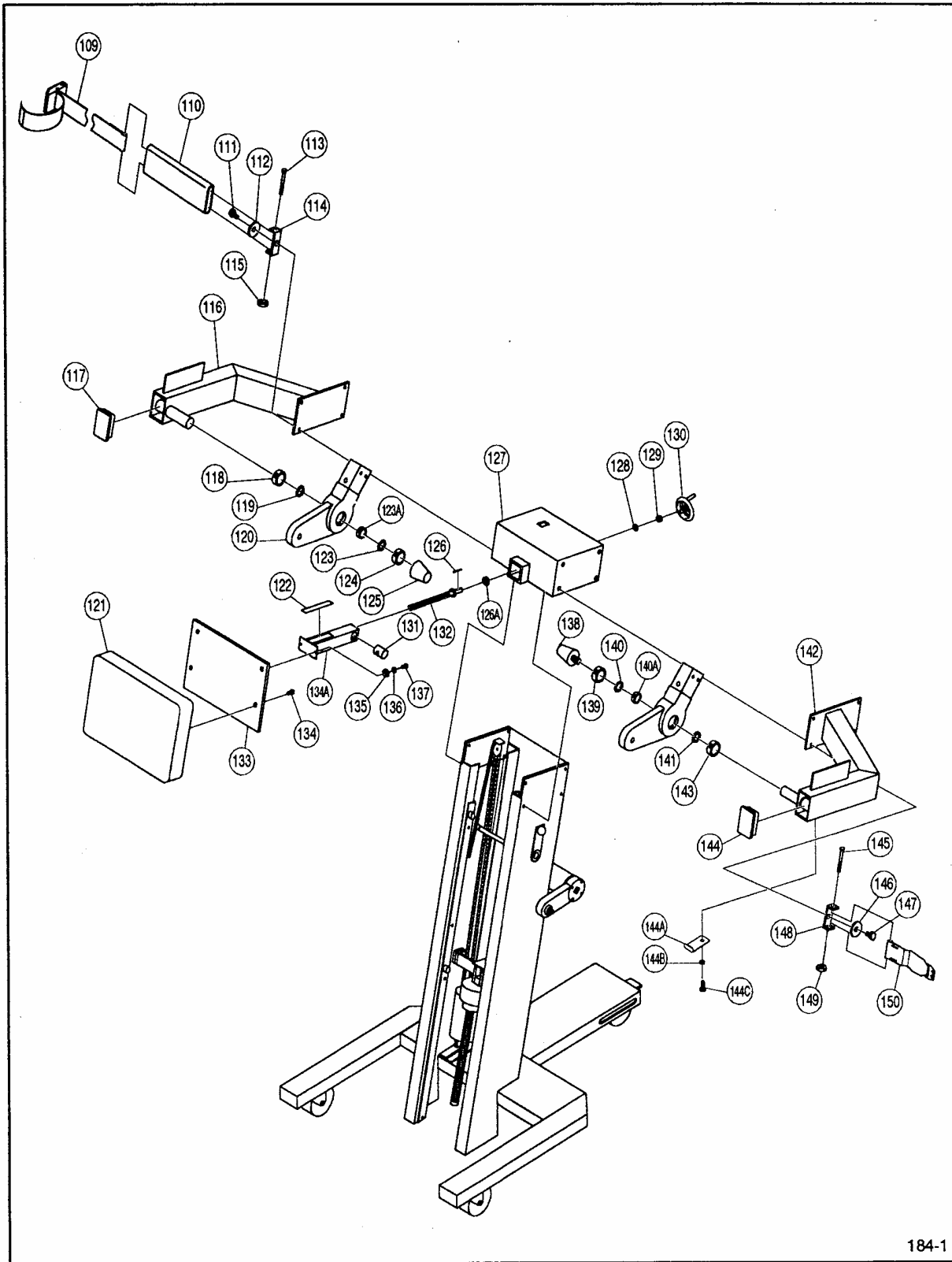
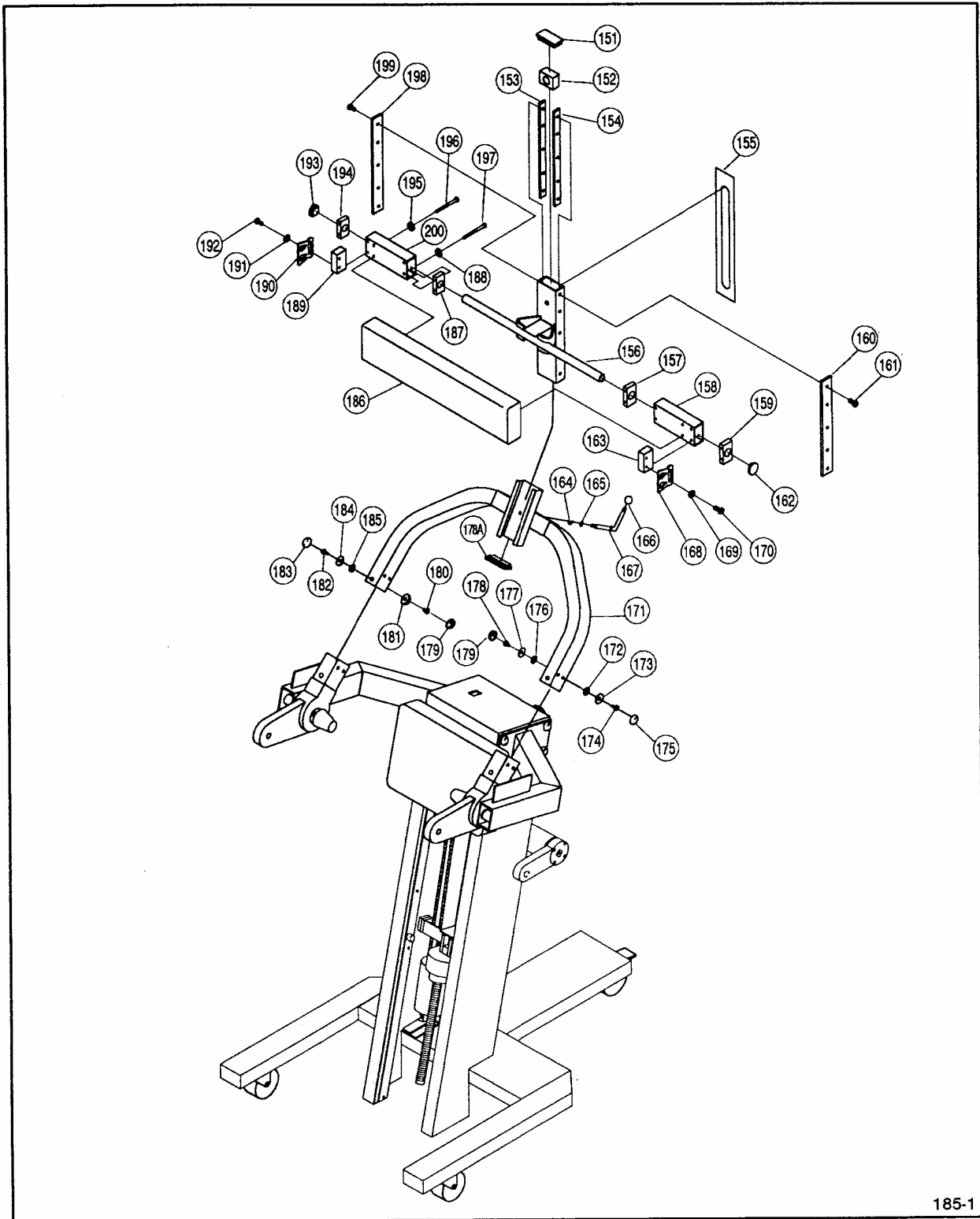

Figure 4-2. Top Cover, Input Arm, Pelvic Belt/Buckle, and Input Pivot Assemblies.

**REPLACEMENT PARTS**

<b>REF.</b>	<b>DESCRIPTION</b>	<b>PART NO.</b>
109	Pelvic Belt/Buckle Assembly	7310S078
110	Belt Pad	3400U216
111	Screw, 3/8-16x1/4 Hex Head Cap	HC701220
112	Cap Screw Washer (3/8)	HS010000
113	Screw, 3/8-16x3 Hex Head Cap	HC701234
114	Belt Bracket, Pelvic	7310C067
115	Nut, 3/8-16 Hex Center Lock	HN704002
116	Weldment, Input Pivot Arm (Right)	7310C089
117	Insert Glide, 2x3x1/2 GA Black	PP120005
118	Modified Split Collar	7310M091
119	Spacer, Bearing	7310M090
120	Pivot Input	7310C650
121	Back Cushion Assembly	1750U110
122	Fore-Aft Drum Scale	CM000127-1
123	Spacer, Bearing	7310M090
123A	Bearing, Spherical 1.750OD	FB030029
124	Split Collar	AB030030
125	Bumper, Vibration Mount (Axis Ind)	PR069473
126	Key, 1/8x1/8x1-1/4 Lg.	BK030020
126A	Thrust Washer	HS387604
127	Weldment, Top Cover	7310C701
128	Flanged Bearing	FB050044
129	Clamp Collar, 1/2	AB030028
130	Revolving Handle Wheel	3400M426
131	Pivot	7310M702
132	Acme Shaft	7310M703
133	Weldment, Cushion Mtg Plate	7310C708
134	Pan-L, Phl, 1/4-20x3/4	HM622515-1
134A	Weldment, Telescoping Tube	7310C711
135	Flat Washer (1/4) 1/20Dx.281IDx.062TK	HS307601
136	Lockwasher, .4890Dx.255IDx.062T	HS308300
137	Screw, 1/4-20x5/8 Hex Head Cap	HC621214
138	Bumper, Vibration Mount (Axis Ind)	PR069473
139	Split Collar	AB030030
140	Spacer Bearing	7310M090
140A	Bearing Spherical 1.750OD	FB030029
141	Spacer Bearing	7310M090
142	Weldment, Input Pivot Arm (Left)	7310C050
143	Modified Split Collar	7310M091
144	Insert Glide, 2x3x1/2 GA Black	PP120005
144A	Bracket, Hanger	7310C093
144B	Lockwasher, #10 Split	HS108302
144C	Screw, Low Soc Head Cap, 10-32x1/2	HM583412
145	Screw, 3/8-16x3 Hex Head Cap	HC701234
146	Cap Screw Washer (3/8)	HS010000
147	Screw, 3/8-16x1-1/4 Hex Head Cap	HC701220
148	Bracket, Pelvic Belt	7310C067
149	Nut, 3/8-16 Hex Center Lock	HN704002
150	Buckle Release Belt Assembly	175S672-1



185-1

Figure 4-3. Scapula Pad and Input Frame Assemblies.

REF.	DESCRIPTION	PART NO.
151	Insert Glide, 1-1/2x2x11GA.	PP320001
152	Block Lock	7310M682
153	Block, Mounting, Delrin Strip	7310M679
154	Block, Mounting, Delrin Strip	7310M679
155	Label, Scapula Pad Position Scale	731CM683
156	Weldment, Scapula Pad Mounting Bracket	7310C690
157	Delrin Block	7310M623
158	Tube, Pad Mounting	7310C696
159	Delrin Block	7310M623
160	Slide Strip	7310M694
161	Screw, 10-32x1/2" Socket Flat Head	HM581012
162	Insert Glide, 1.25 Dia x 11 GA.	PP280010
163	Buckle Bracket	7310C689
164	Label	731CM225
165	Flat Washer, Delrin, .401IDx.7500Dx.125	HS348001
166	Ball Knob	PP460024
167	Weldment, Lock Handle	7310C680
168	Release Fitting, Basic	FC030006
169	Lockwasher, .4890Dx.255IDx.062T	HS308300
170	Screw, .1/4-20x3/4 Button Head Cap	HC620415
171	Input Frame Weldment	7310C640
172	Cap Screw Washer (5/16)	HS010002
173	Lockwasher (5/16) .5860Dx5/16Dx.07T	HS328300
174	Screw, 5/16-18x3/4 Hex Head Cap	HC661215
175	Screw Cap	PP080006
176	Cap Screw Washer (5/16)	HS010002
177	Lockwasher (5/16) .5860Dx.5/16IDx.07T	HS328300
178	Insert Glide, 1-1/2x2x11GA	HC661215
178A	Screw, 5/16-18x3/4 Hex Head Cap	PP080006
179	Screw Cap	PP080006
180	Screw, 5/16-18x3/4 Hex Head Cap	HC661215
181	Recess Bumper	PR060003
182	Screw, 5/16-18x3/4 Hex Head Cap	HC661215
183	Screw Cap	PP080006
184	Lockwasher (5/16) .5860Dx5/16Dx.07T	HS328300
185	Cap Screw Washer (5/16)	HS010002
186	Scapula Pad S/A	7310S699
187	Delrin Block	7310M623
188	Flat Washer (1/4) 1/20Dx.281IDx.062TK.	HS307601
189	Buckle Bracket	7310C689
190	Release Fitting, Basic	FC030006
191	Lockwasher, .4890Dx.255IDx.062T	HS308300
192	Screw, 1/4-20x3/4 Button Head Cap	HC620415
193	Insert Glide, 1.25 Dia x 11 GA.	PP280010
194	Delrin Block	7310M623
195	Flat Washer (1/4) 1/20Dx.281IDx.062TK.	HS307601
196	Screw, 1/4-20x2-3/4 Hex Head Cap	HC62132
197	Screw, 1/4-20x2-3/4 Hex Head Cap	HC62132
198	Slide Strip	7310M694
199	Screw, 10-32x1/2" Socket Flat Head	HM581012
200	Tube, Pad	

# REPLACEMENT PARTS

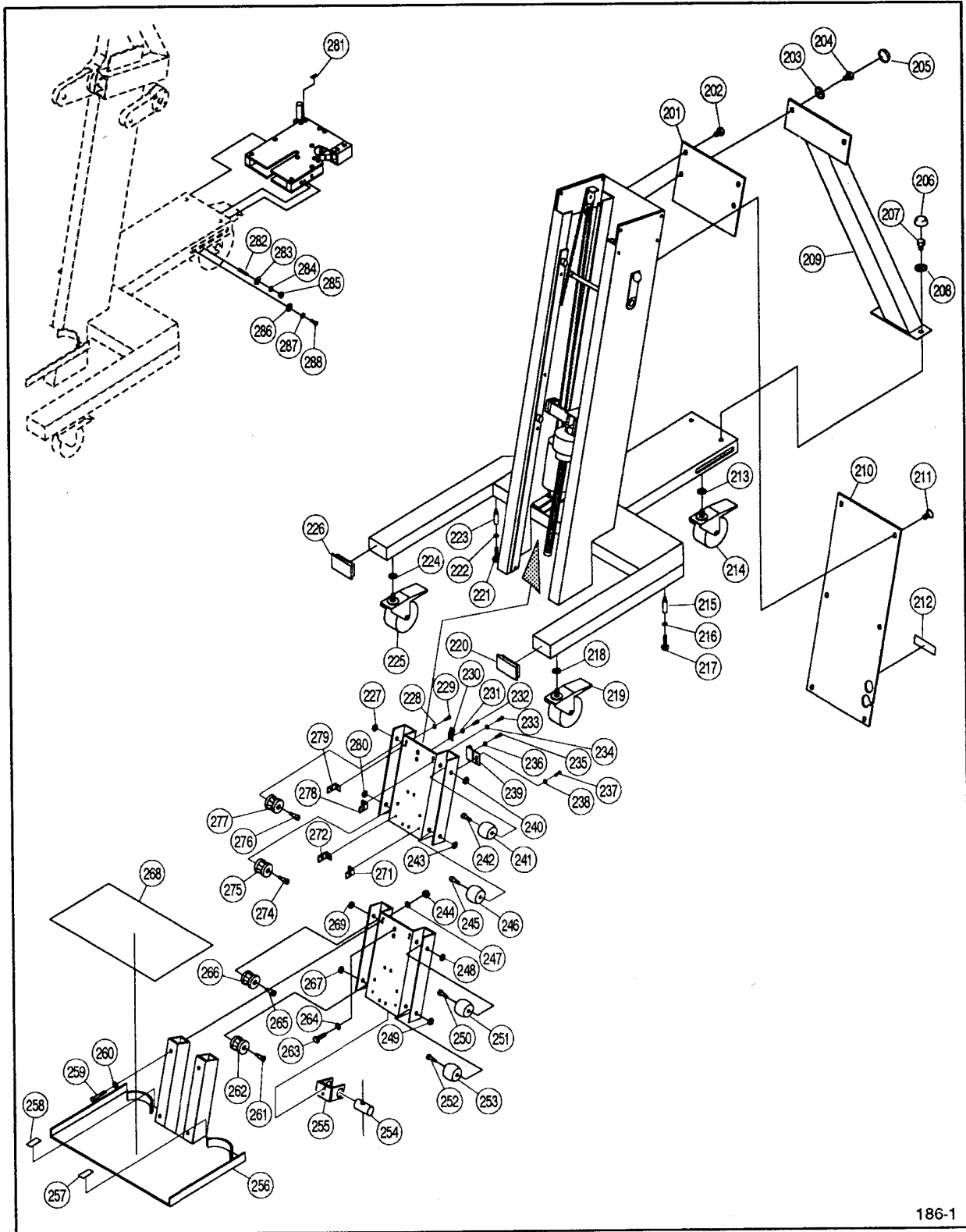

186-1

Figure 4-4. Roller/Footplate Carriage, Rear Strut, Docking Adapter Assemblies



**REPLACEMENT PARTS**

REF.	DESCRIPTION	PART NO.	REF.	DESCRIPTION	PART NO.
201	Panel, Back Top	7310C073	260	Flat Washer (5/16) 7/80Dx3/8IDx.078TK	HS327500
202	Pan-L-Screw, #10-32 UNF x 1/2	HM581812-1	261	Screw, Modified Socket Head Shoulder	7310M092
203	Cap Screw Washer (3/8)	HS010000	262	Roller, Guided	7310M215
204	Screw, 3/8-16x1 Hex Head Cap	HC701217	263	Screw, 3/8-16x1 Hex Head Cap	HC701217
205	Screw Cap	PP080006	264	Lockwasher (3/8) .6850Dx.391IDx.095T	HS348300
206	Screw Cap	PP080006	265	Screw, Modified Socket Head Shoulder	7310M092
207	Screw, 3/8-16x5/8 Hex Head Cap	HC701214	266	Roller, Guided	7310M215
208	Cap Screw Washer (3/8)	HS010000	267	Nut, 1/4-20 Hex Jam	HN624400
209	Weldment, Rear Support	7310C066	268	Safety Walk	PR520004
210	Panel, Back	7310C072	269	Nut, 1/4-20 Hex Jam	HN624400
211	Pan-L-Screw, #10-32 UNF x 1/2	HM581812-1	270	Roller Carriage	7310C213
212	Label, TMC	731CM100	271	Cover Bracket	7310M083
213	Flat Washer (1/2) 1-3/80Dx9/16IDx.11T.	HS387500	272	Cover Bracket	7310M083
214	Wheel	WB021500	273	Roller, Carriage	7310C213
215	Standoff, Base Frame	7310C095	274	Screw, Modified Socket Head Shoulder	7310M092
216	Nut, 1/2-13 Regular Hex Jam	HN784400	275	Roller, Guided	7310M215
217	1/2-13 Leveling Glide	HG780029	276	Screw, Modified Socket Head Shoulder	7310M092
218	Flat Washer (1/2) 1-3/80Dx9/16IDx.11T.	HS387500	277	Roller, Guided	7310M215
219	Wheel	WB021500	278	Bracket, Cover	7310M083
220	Insert Glide, 2x3x11GA. Black	PP120005	279	Bracket, Cover	7310M083
221	Nut, 1/2-13 Regular Hex Jam	HN784400	280	Nut, 1/4-20 Hex Jam	HN624400
222	1/2-13 Leveling Glide	HG780029	281	Flat Washer (3/8) .8120Dx.406IDx.065T	HS347600
223	Standoff, Base Frame	7310C095	282	Screw, Set, 1-4/20x1-1/4	HY622920
224	Flat Washer (1/2) 1-3/80Dx9/16IDx.11T.	HS387500	283	Flat Washer (1/4) 5/80Dx9/32IDx.062TH	HS307600
225	Wheel	WB021500	284	Lockwasher, .4890Dx255IDx.062T	HS308300
226	Insert Glide, 2x3x11GA. Black	PP120005	285	Nut, 1/4-20 Hex	HN624100
227	Nut, 1/4-20 Hex Jam	HN624400	286	Flat Washer (3/8) 1.00Dx7x161IDx.083T	HS347500
228	Lockwasher, #8 Med Split	HS088300	287	Lockwasher (3/8) .6850Dx.391Dx.095T	HS348300
229	Screw, 8-32x1/2 Socket Head	HC542812	288	Screw, 3/8-16x1 Hex Head Cap	HC701217
230	Bracket, Carriage	7310M315			
231	Lockwasher, #10 Split	HS108302			
232	10-32x1/2 Soc Head Cap	HM582812			
233	Screw, 8-32x1/2 Socket Head	HC542812			
234	Lockwasher, #8 Med. Split	HS088300			
235	Screw, 10-32x1/2 Socket Head Cap	HM582812			
236	Lockwasher, #10 Split	HS108302			
237	Screw, 10-32x1/2 Socket Head Cap	HM582812			
238	Lockwasher, #10 Split	HS108302			
239	Weldment, Short Gear Rack	7310W311			
240	Nut, 1/4-20 Hex Jam	HN624400			
241	Roller	7310M214			
242	Screw, Modified Socket Head Shoulder	7310M092			
243	Nut, 1/4-20 Hex Jam	HN624400			
244	Nut, 5/16-18 Hex	HN664000			
245	Screw, Modified Socket Head Shoulder	7310M092			
246	Roller	7310M214			
247	Lockwasher (5/16) .5860Dx5/16IDx.07T	HS328300			
248	Nut, 1/4-20 Hex Jam	HN624400			
249	Nut, 1/4-20 Hex Jam	HN624400			
250	Screw, Modified Socket Head Shoulder	7310M092			
251	Roller	7310M214			
252	Screw, Modified Socket Head Shoulder	7310M092			
253	Roller	7310M214			
254	Pivot	7310M212			
255	Weldment, Pivot Bracket	7310C209			
256	Weldment, Footplate	7310C220			
257	Label, Arrow Indicator	730CM018			
258	Label, Arrow Indicator	730CM018			
259	Screw, 5/16-18x2-1/4 Hex Head Cap	HC661228			

# REPLACEMENT PARTS

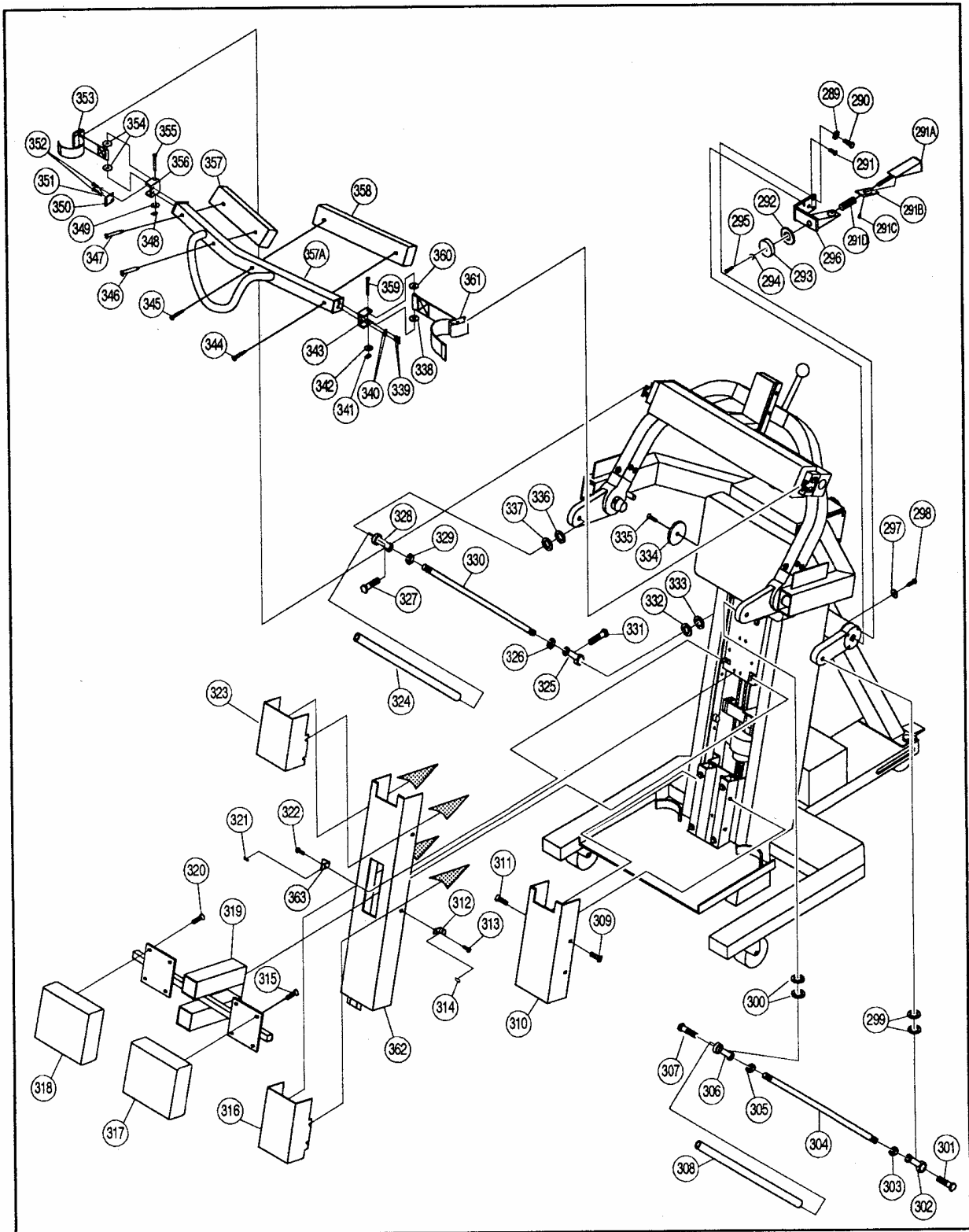

Figure 4-5 Chest Pad, Tie-Rod, Docking Adapter, Popliteal Tube Assemblies.

**REPLACEMENT PARTS**

REF.	DESCRIPTION	PART NO.	REF.	DESCRIPTION	PART NO.
289	Flat Washer (3/8) .8120D x .406IDx.065T	HS347600	343	Belt Support	1750P659
290	Screw, 3/8-16x1-1/2 Hex Head Cap	HC701222	344	Pan-L-Screw, 1/4-20x2-1/4	HM621828
291	Screw, 5/16-18x1/4 Flat Head Socket	HC661015	345	Pan-L-Screw, 1/4-20x2-1/4	HM621828
291A	Clamp Weldment	7310P785	346	Pan-L-Screw, 1/4-20x2-1/4	HM621828
291B	Slide Strip	7310M767	347	Pan-L-Screw, 1/4-20x2-1/4	HM621828
291C	Screw, 4-40x1/4Lg. Slot Head	HM521008	348	Retaining Ring, Ext. 225ID	BR030045
291D	Spring, Compression, 2-1/2	BS070732	349	1/2" Shim	HS307603
292	Thrust Washer, .750 OD x .377ID	FB050055	350	Hanger, Chest Pad	7310P517
293	Vinyl Dipped Knob	731AK790	351	Lockwasher, .4890Dx.255IDx.062T	HS308300
294	Flat Washer (#10) 1/20Dx7/32IDx3/64T	HS107601	352	Screw, 1/4-20x3/4 Hex Head Cap	HC621215
295	10-32x1/2 Round Head Machine Screw	HC582112	353	Chest Pad/Belt Buckle Assembly	1750S657-1
296	Docking Adapter Weldment	7310P780	354	Flatwasher 1.000Dx.260IDx.031TH Nylok	HS008004
297	Lockwasher, .4890Dx.255IDx.062T	HS308300	355	Pin, Clevis Annular, 1/4x2-1/2	HP306530
298	Screw, 1/4-20x5/8 Hex Head Cap	HC621214	356	Belt Support	1750P659
299	1/2" Washer	HS347707	357	Chest Pad S/A	7310S512
300	1/2" Washer	HS347707	357A	Weldment, Chest Cushion Bracket	7310C511
301	Screw, 1/2-13x2	HC782826	358	Chest Pad S/A	7310S512
302	Rod End, 1/2-20, RH Delrin	AP030069	359	Pin, Clevis Annular, 1/4x2-1/2	HP306530
303	Nut, 1/2-20 UNF-2B Hex Jam	HN794400	360	Flatwasher 1.000Dx.260IDx.031TH Nylok	HS008004
304	Tie Rod	7310C502	361	Chest Pad/Belt Buckle Assembly	1750S657-1
305	Nut, Hex Jam, 1/2-20 LH Thread	HN794401	362	Popliteal Carriage Cover	7310C087
306	Rod End, 1/2-20, LH Delrin	AP030070	363	Bracket, Pointer	7310C327
307	Screw, 1/2-20x1-3/4 Socket Head Cap	HC792824			
308	Foam Grip	1670M115			
309	Screw, 8-32x1/4, Low Socket Head Cap	HC543408			
310	Cover, Foot Plate Carriage	7310C086			
311	Screw, 8-32x1/4, Low Socket Head Cap	HC543408			
312	Bracket, Pointer	7310C327			
313	Pan-L-Screw 8-32x1/2	HM541812-1			
314	Label, Arrow Indicator	730CM018			
315	Pan-L, Philips, 1/4-20x3/4	HM622515-1			
316	Cover, Middle	7310C085			
317	Popliteal Cushion	1750U081			
318	Popliteal Cushion	1750U081			
319	Weldment, Popliteal Receiving Tube	7310C301			
320	Pan-L, Philips 1/4-20x3/4	HM622515-1			
321	Label, Arrow Indicator	730CM018			
322	Pan-L-Screw, 8-32x1/2	HM541812-1			
323	Cover, Front Top	7310C084			
324	Foam Grip	1670M115			
325	Rod End, 1/2-20, RH Delrin	AP030069			
326	Nut, 1/2-20 UNF-2B Hex Jam	HN794400			
327	Screw, 1/2-20x1-3/4 Socket Head Cap	HC792824			
328	Rod End, 1/2-20, LH Delrin	AP030070			
329	Nut, Hex Jam, 1/2-20, LH Thread	HN794401			
330	Tie Rod	7310C502			
331	Screw, 1/2-13x2	HC782826			
332	1/2" Washer	HS347707			
333	1/2" Washer	HS347707			
334	End Cap	7310C728			
335	Screw, 5/16-18x3/4 Flat Head Socket	HC661015			
336	1/2" Washer	HS347707			
337	1/2" Washer	HS347707			
338	Flatwasher 1.000Dx.260IDx.031TH Nylok	HS008004			
339	Screw, 1/4-20x3/4 hex Head Cap	HC621215			
340	Lockwasher, .4890Dx.255IDx.062T	HS308300			
341	Retaining Ring, Ext. 225ID	BR030045			
342	1/2" Shim	HS307603			

# REPLACEMENT PARTS

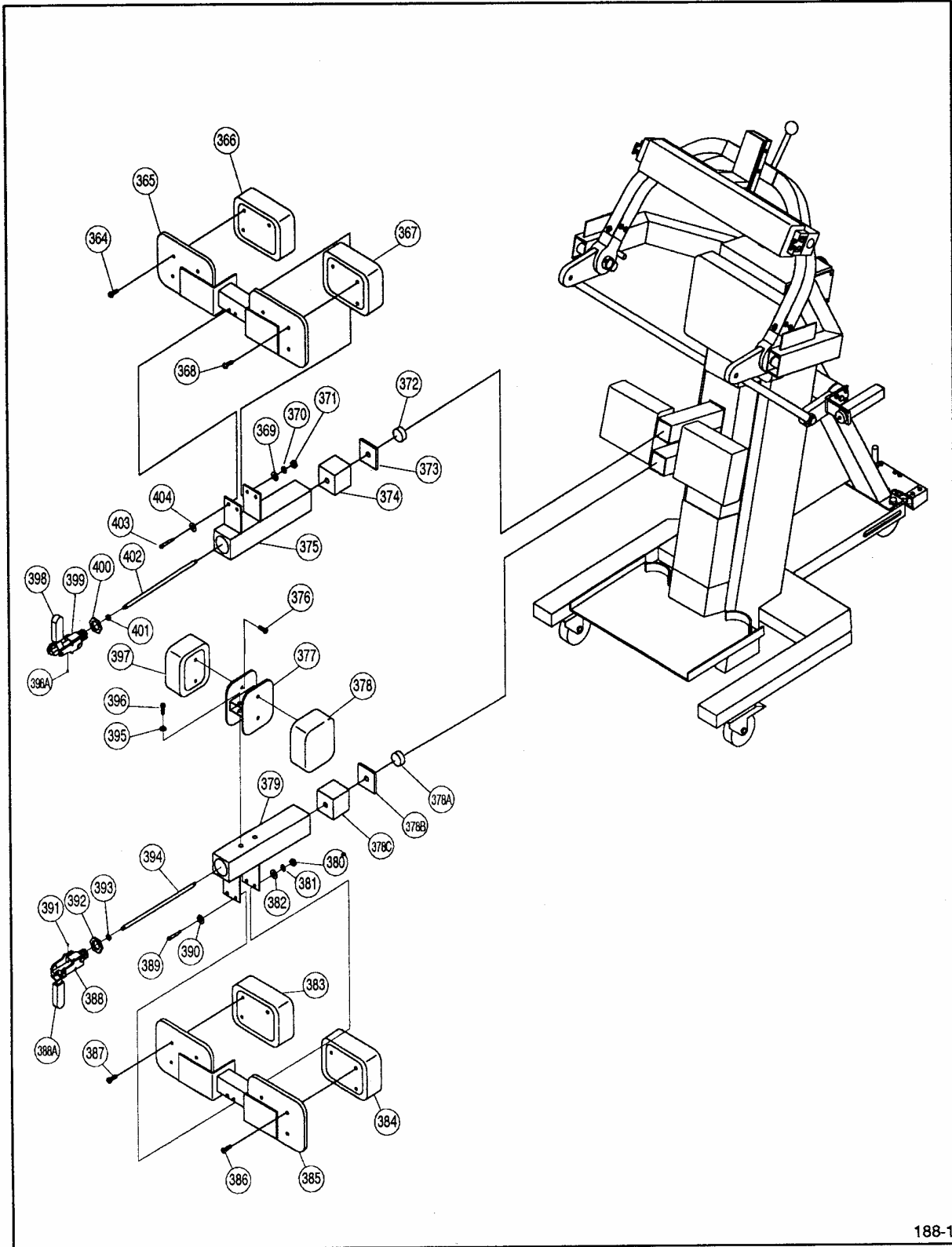
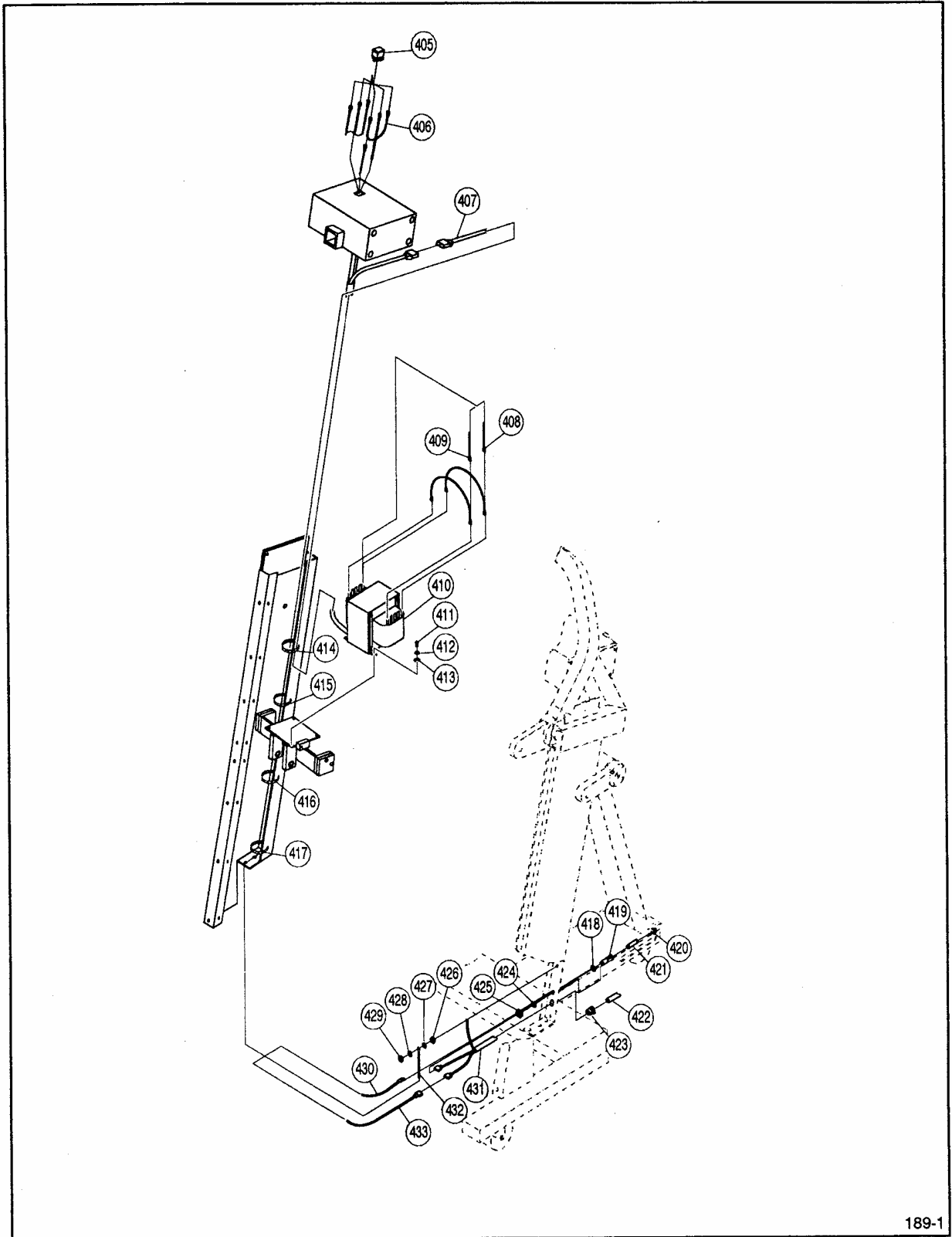

Figure 4-6 Toggle Clamp, Thigh / Knee and Tibial Pad Assemblies.

**REPLACEMENT PARTS**

<b>REF.</b>	<b>DESCRIPTION</b>	<b>PART NO.</b>
364	Pan-L, Philips, 1/4-20x3/4	HM622515-1
365	Cushion Bracket	1750C082
366	Thigh/Tibial Cushion	1750U067
367	Thigh/Tibial Cushion	1750U067
368	Pan-L, Philips, 1/4-20x3/4	HM622515-1
369	Flat Washer (1/4) 5/80Dx9/32IDx.062TH	HS307600
370	Lockwasher (1/2) .4890Dx.255IDx.062T	HS308300
371	Nut, 1/4-20 Hex	HN624100
372	Shaft Collar	AB030027
373	Clamp Washer	1750P068
374	Clamp Bushing	1750M069
375	Mounting Tube	1750P076
376	Screw, 1/4-20x5/8 Socket Flat Head	HM620914
377	Knee Cushion Bracket	1750C056
378	Knee Cushion Assembly	1750C059
378A	Shaft Collar	AB030027
378B	Mounting Tube	1750P068
378C	Nut, 1/4-20 Hex	1750M069
379	Mounting Tube	1750P052
380	Nut, 1/4-20 He	HN624100
381	Flat Washer (1/2) .4890Dx.255IDx.062T	HS308300
382	Flat Washer (1/4) 5/80Dx9/32IDx.062TH	HS307600
383	Thigh/Tibial Cushion	1750U067
384	Thigh/Tibial Cushion	1750U067
385	Cushion Bracket	1750C079
386	Pan-L, Philips, 1/4-20x3/4	HM622515-1
387	Pan-L, Philips, 1/4-20x3/4	HM622515-1
388	Modified Toggle Clamp	1750M070
388A	Clamp Sleeve (Black)	PP129701-1
389	Screw, 1/4-20x2-1/4 Hex Head Cap	HC621228
390	Flat Washer (1/4) 5/80Dx9/32IDx.062TH	HS307600
391	Drive Screw, #2x3/16	HX012007
392	P/O Modified Toggle Clamp	1750M070
393	Nut, 3/8-16 Jam	HN704400
394	Clamp Rod	1750P071
395	Lockwasher (1/2) .4890Dx.255IDx.062T	HS308300
396	Screw, 1/4-20x1/2 Socket Head Cap	HC622812
397	Knee Cushion Assembly	1750U059
398	Clamp Sleeve (Black)	PP129701-1
398A	Screw, #2x3/16 Large Drive	HX012007
399	Modified Toggle Clamp	1750M070
400	P/O Modified Toggle Clamp	1750M070
401	Nut, 3/8-16 Jam	HN704400
402	Clamp Rod	1750P071
403	Screw, 1/4-20x2-1/4 Hex Head Cap	HC621228
404	Flat Washer (1/4) 5/80Dx9/32IDx.062TH	HS307600



189-1

Figure 4-7. Internal Isolation Transformer, Footplate Switch Assemblies (Units made before 1997.)

<b>REF.</b>	<b>DESCRIPTION</b>	<b>PART NO.</b>
405	Rocker Switch	ES110731
406	Jumper S/A	7310S955
407	Ground Wire S/A	7310S960
408	Wire S/A, Fuse To Switch, Black	7310S975
409	Wire S/A, Power Cord to Switch, White	7310S980
410	Transformer	ET300026
411	Screw #10-24x5/8, Socket Head Cap	HC572814-1
412	Lockwasher, #10 Split	HS108302
413	Flat Washer, 1/20ODx 7/32IDx3/64T	HS107601
414	Cable Ties, 5/8-3/4 Dia.	EW000013
415	Cable Ties, 5/8-3/4 Dia.	EW000013
416	Cable Ties, 5/8-3/4 Dia.	EW000013
417	Cable Ties, 5/8-3/4 Dia.	EW000013
418	Rubber Washer (supplied with fuse holder)	EF000731
419	Fuse Holder	EF000731
420	Fuse Holder Cap (supplied with fuse holder)	EF000731
421	5 Amp 250V Slo-Blo Fuse	EF290011
422	Line Cord S/A	7310S950
423	Strain Relief	EL270008
424	Internal Tooth Star Washer (supplied with fuse holder)	EF000731
425	Hex Nut (supplied with fuse holder)	EF000731
426	Lockwasher, #8 Med Split	HS088300
427	Nut, 8-32 Hex	HN544101
428	Lockwasher, #8 Med Split	HS088300
429	Nut, 8-32 Hex	HN544101
430	Wire S/A, Fuse to Switch, Black	7310S975
431	Line Cord S/A	7310S950
432	Ground Wire S/A	7310S960
433	Wire S/A, Power Cord to Switch, White	7310S980

# REPLACEMENT PARTS

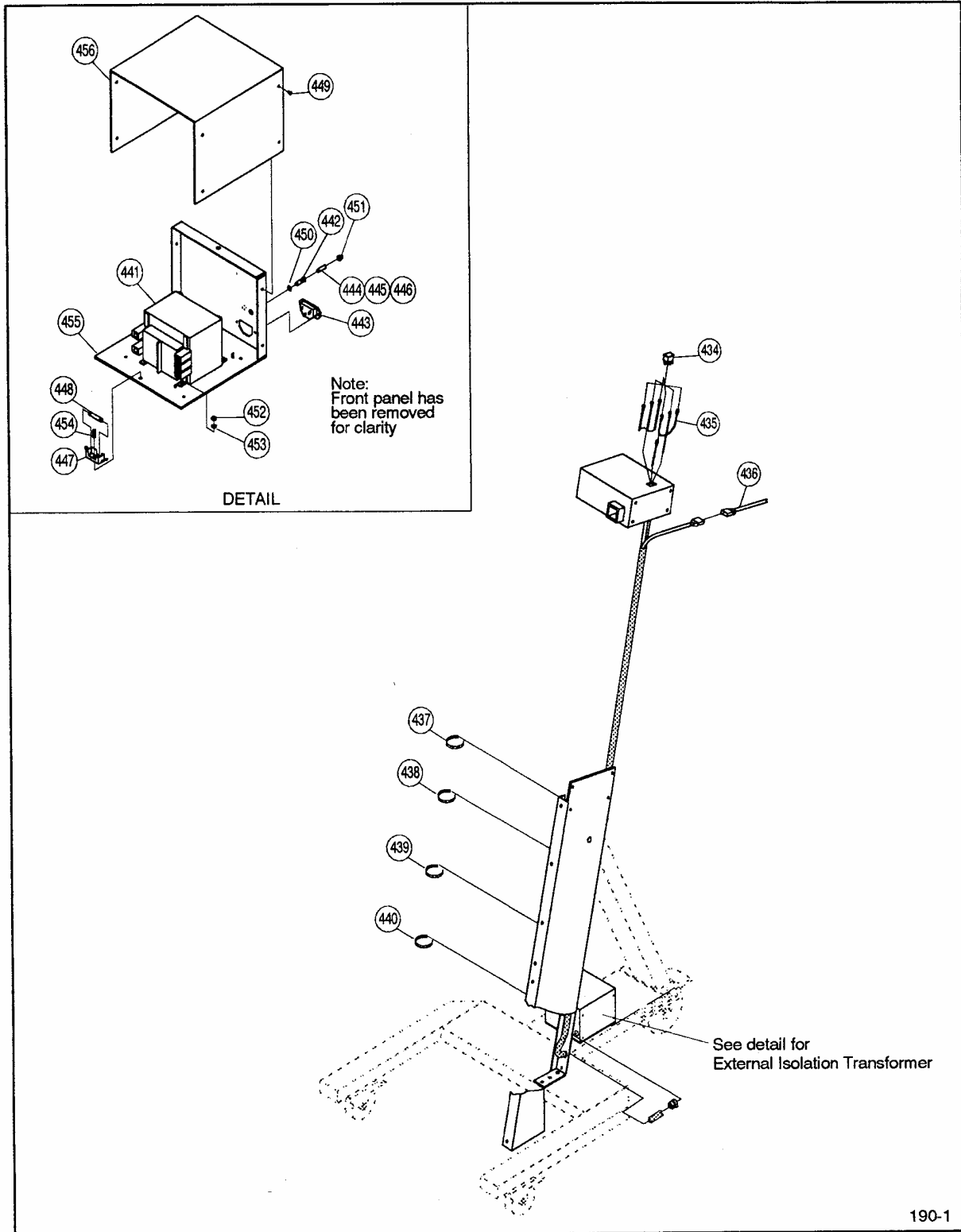

Figure 4-8 External Isolation Transformer, Footplate Switch Assemblies (Units made after Jan. 1997.)



<b>REF.</b>	<b>DESCRIPTION</b>	<b>PART NO.</b>
434	Rocker Switch	ES110731
435	Jumper S/A	7310S955
436	Ground Wire S/A	7310S960
437	Cable Ties, 5/8-3/4 Dia.	EW000013
438	Cable Ties, 5/8-3/4 Dia.	EW000013
439	Cable Ties, 5/8-3/4 Dia.	EW000013
440	Cable Ties, 5/8-3/4 Dia.	EW000013
441	Transformer	ET490036
442	Fuseholder, 3AG., Panel Mount	EF000731
443	Power Inlet, IEC	ES000731
444	Fuse, 2.5A Slo-Blo	EF000024
445	Fuse, 3.0A Slo-Blo	EF290004
446	Fuse, 1.5A Slo-Blo	EF000023
447	Fuseholder, 3AG.	EF000770
448	Fuse, 2.5A Slo-Blo	EF000024
449	Screw, 6-32x1/4 w/Lock Washer	HM532508
450	Rubber Washer (supplied with fuse holder)	EF000731
451	Fuse Holder Cap (supplied with fuse holder)	EF000731
452	Nut, 10-24 Hex	HN574100
453	Washer, #10 External Tooth Star	HS108301
454	Screw, 6-32x3/8	HM532410
455	Housing, Transformer, Domestic	7310C097
456	Cover, Transformer	7310C096



**NOTES**