



SERVICE MANUAL

HPV Axial Piston Pumps

“B” Design Series



CAUTION – Before performing any service operation on any pump, be sure that all pressure has been relieved from the system.

CAUTION – Before performing any service operation on any pump, disconnect or lock off power supply.

CAUTION – Before starting any pump, be sure that any resulting machine function will not endanger persons or equipment.

PRODUCT IDENTIFICATION

Each HPV Piston Pump has a Model Code stamped on its escutcheon plate. See Figure 1 for the location of the Model Code.

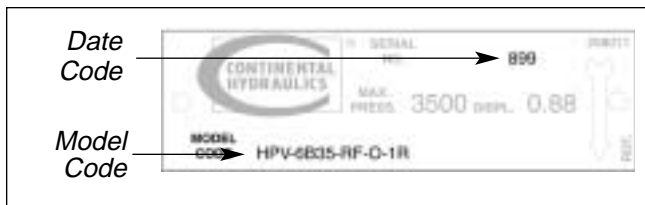

Figure 1

This Service Booklet applies to products with Model Codes like the sample in Figure 2.

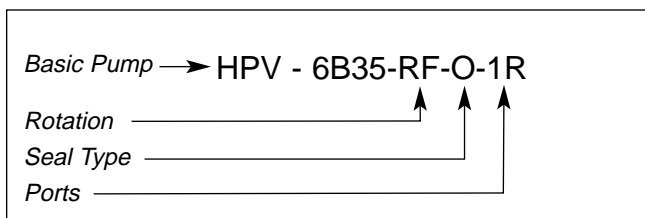

Figure 2

GENERAL SPECIFICATIONS

MOUNTING

Any unrestricted mounting position acceptable. Horizontal mounting preferred. The mounting hub and two-bolt mounting flange conform to SAE mounting standards.

Continental Hydraulics does not recommend direct rigid connection of piston pumps to the Prime Mover. Use of a flexible coupling, a coupling that allows for minor misalignment is recommended.

If the shaft connection to the Prime Mover is rigid, the mounting face diametric concentricity and squareness must be within .001 inch (0.03 mm) T.I.R. for a flange mounted pump.

The HPV Piston Pump is designed for in-line drive. Angle drive creates side loads on the shaft, and is not acceptable.

SHAFT INFORMATION

Splined:

The coupling interface must be lubricated. Continental Hydraulics recommends lithium molydisulfate, or similar grease. The female coupling should be hardened to 27-45 Rc, and must conform to ANSI B92.1 Class 5 Fillet or Flat Root Side Fit.

Keyed:

High strength heat treated keys must be used. Replacement keys must be hardened to 27-34 Rc. Key corners must be chamfered .030 - .040 inch (.75 - 1.0 mm) at 45° to clear radii in the keyway.

PLUMBING

Connect inlet and outlet lines to the pump's cover. HPV fluid connections are SAE straight thread, SAE flange or BSPP.

MODEL	REAR PORT	SIDE PORT
HPV-6	SAE-12 or 3/4" BSPP	SAE-16 or 1" BSPP
HPV-10	SAE-20 or 1-1/4" BSPP	SAE-20 or 1-1/4" BSPP
HPV-15	SAE-20 or 1-1/4" BSPP	SAE-20 or 1-1/4" BSPP
HPV-20	SAE-20 or 1-1/4" BSPP	SAE1-1/4" Flange*
HPV-29	SAE-20 or 1-1/4" BSPP	SAE1-1/2" Flange**

* Per Code 62 ** Per Code 61

Maximum case pressure is 10 psi (0.70 bar). Case pressure must never exceed inlet pressure by more than 15 psi (1.0 bar). To prevent fluid drain-down from the pump when idle, make certain that case drain plumbing passes above the highest point of the pump before entering the reservoir. Or, install a 5 psi (.3 bar) case pressure check valve to assure that the pump is always filled with hydraulic fluid.

The case drain line must be big enough to prevent back pressure in excess of 10 psi (0.70 bar).

PLUMBING (continued...)

Hydraulic fluid from the case drain line should be returned to the reservoir below the fluid level, and as far from the supply intake as possible. All fluid lines (whether pipe, tubing or hose) must be of adequate size and strength to assure free flow through the pump. Do not tee return lines together.

SYSTEM RELIEF VALVES

Although HPV series pumps have a very fast off-stroke compensator response, fast acting relief valves are recommended in all cases for safety. They also help reduce transient pressure spikes.

RECOMMENDED FLUID



Note: The following fluid recommendations and specifications apply to HPV series pumps only. Assure that all other components in the hydraulic system have compatible requirements.

Petroleum-based, and most phosphate esters. Fluids should be designated by the manufacturer for use in hydraulic systems. Fluids should be formulated with oxidation inhibitors, anti-rust, anti-foam and deaerating agents. Other fluids may be acceptable, but special O-rings may be required. Nitrile (Buna) seals are standard.

VISCOSITY

Maximum at full power750 SUS (160 Cst)
Optimum for maximum life140 SUS (30 Cst)
Minimum at full power 60 SUS (10 Cst)

VISCOSITY INDEX

90 V.I. minimum. Higher values extend the operating temperature range, but may reduce fluid service life.

Fluid Operating Temperature – Operating temperature should be determined by the viscosity characteristics of the fluid used. Fluid temperature in the reservoir during operation should be kept between 100° F. and 130° F. (38° C. and 54° C.) Because high temperature degrades seals, reduces service life and creates hazards, fluid temperature should not exceed 180° F. (82° C.) at the case drain.



CAUTION – Fluid temperatures in excess of 120° F. (49° C.) can cause serious burns and scalding. Allow fluid to cool before performing any repairs or maintenance.

Fluid Cleanliness – Control particle contamination by changing or cleaning all filter elements periodically BEFORE they become clogged and start to by-pass. Fluid must be cleaned before and continuously during operation to a cleanliness level of ISO 18/16/13 or better. This level of cleanliness can usually be accomplished by use of 10 micron filters. Better fluid cleanliness will significantly extend component life. Since contaminant generation varies with each application, each must be analyzed to determine proper filtration to maintain required cleanliness.

After Extended Shutdowns – Some types of hydraulic fluids become tacky after long periods of non-use. If possible, hand turn the pump several times after extended shutdowns to assure that all components move freely before powering up.



CAUTION – Before hand turning any pump, be sure that any resulting machine function will not endanger persons or equipment.

PREVENTIVE MAINTENANCE

This pump is self-lubricating. Preventive maintenance is limited to keeping the system fluid clean by changing filters regularly. Since filtering needs can vary depending on applications, filters used with this pump should be equipped with indicators that show when changes are needed. Do not operate the pump in a system with clogged or bypassing filters.

Keep all fittings and screws tight. Do not operate this pump at pressures or speeds in excess of stated limits. If the pump does not operate properly, check the Trouble Shooting Section of this manual before attempting to overhaul the pump.

Overhauls are relatively simple, and are covered in the Repair Procedures Section of this manual.



Note: It is especially important to keep suction or inlet piping and fittings tight and in good repair. Air drawn into the system through loose or damaged intake fittings can cause the pump to fail.

START UP PROCEDURE FOR NEW INSTALLATION

1. Read and understand the Service Manual. Identify components and their functions.

2. Visually inspect system components and lines for possible damage.

3. Check reservoir for cleanliness. Drain and clean as required.

4. Check reservoir fluid level and fill as required with filtered fluid that

meets or exceeds ISO 18/16/13 cleanliness level. Fill pump through either Case Drain Port (Figure 3).

5. Check drive alignment.

6. Check and activate oil cooler (if included in circuit). Check fluid temperature.

7. Reduce relief valve pressure settings. Make sure accurate pressure readings can be made at appropriate places.

8. If the system includes solenoids, check for proper actuation.

9. Jog electric motor to confirm proper rotation. Jogging the electric motor primes the pump and bleeds air from the system.

10. Start pump drive. Look for leaks, and listen for excessive noise at the pump. If leaks, chattering or other noises are observed, immediately turn the pump off. Corrective actions are covered in the Trouble Shooting Section.

11. Cycle unloaded machine at low pressure, and observe actuation (at low speed, if possible).

12. Increase pressure settings gradually. Check for leaks in all lines, especially in the pump inlet line.

13. Adjust system pressure as needed.

14. Gradually increase system speed to normal operating level. Be alert for trouble as indicated by noise, sound changes, system shocks, leaks, or air bubbles in the reservoir.

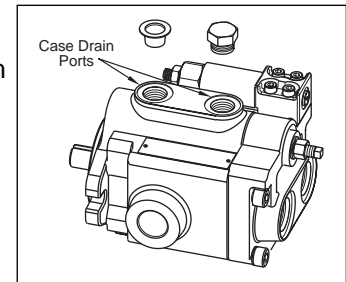

Figure 3

START UP PROCEDURE (continued...)

15. When the system is running normally, check fluid level and temperature at the reservoir. Repeat these checks periodically. Excessive fluid temperatures will damage the pump. If fluid temperature does not stabilize at 140° F (60° C.) or less, stop the system and take appropriate corrective action.

16. System is operational. Follow appropriate maintenance procedures to assure fluid cleanliness and proper operating temperature.

REPLACEMENT PUMP INSTALLATION



To prevent premature pump failure, make sure that the entire hydraulic circuit is flushed completely clean before installing and operating a replacement pump.

Simply draining the reservoir or relying on the system's filters is not enough to adequately clean the fluid. Debris trapped in other components or lines may damage the components themselves, or be drawn into the pump. Failure to properly flush the system before installing a replacement pump voids the pump's warranty.

The following procedures checklist will help you replace a hydraulic pump with confidence that it will provide satisfactory pump life.

1. Determine the cause of the failure (be sure you have found the cause, and not simply a symptom).
2. Eliminate the cause of the failure.
3. Drain the entire circuit, including cylinders, motors, reservoirs, control valves, heat exchangers, and filters.
4. Remove system lines and components. Flush with a compatible solvent, or clean filtered oil to remove contamination that may have entered the system when the pump failed. Be certain that fluid has been flushed from cylinders.

5. Visually inspect components for possible contamination, and for proper operation. Pay special attention to wipers on cylinder rods. Be sure that the rods are free of nicks and scratches.

6. Flush the reservoir using pressurized solvent. Use clean, dry, lint-free cloths to ensure a clean interior. Inspect the filler/breather (if used) and the suction strainer for cleanliness.

7. Install a new filter with a 10 micron or better element, and low Beta ratio. If the machine does not have a filter, install one that meets these specifications.

8. Fill the reservoir with new, FILTERED oil of the recommended type. Be certain to monitor the fluid level, since the entire system (not just the reservoir) must be filled.

9. Re-install all system lines. Visually inspect to make sure they are clean, and free of contamination. Be sure that all inlet fittings are tight and clean.

10. Install the new pump.

11. Follow the start-up procedures given on pages 2 and 3 of this manual.

12. Cycle all cylinders and operate all motors at normal operating speeds for 20 minutes. While operating, observe the reservoir fluid level, since all components will be filling with hydraulic fluid.

13. Replace the filter element, and check the fluid level. Add new, clean, filtered oil if required.

To assure that your replacement pump performs at the same level as the original pump, check daily for proper fluid level, filter condition and leaks. Change fluid at recommended intervals. Good fluid maintenance is especially important when using other than mineral based fluids.

TROUBLESHOOTING GUIDE

Component problems and circuit problems are often interrelated. A poorly designed circuit may operate with apparent success, but cause a component of the system to fail. The component failure is the effect,

not the cause of the problem. The following general guide is offered to help you locate and eliminate the cause of problems by studying their effects.

Problem	Possible Cause	Look For
Noisy Pump	Air in fluid	Leak in suction line Leak in shaft seal Low fluid level Turbulent fluid Return lines above fluid level Gas leak from accumulator Excessive pressure drop in the inlet line from a pressurized reservoir
	Cavitation in pump rotating group	Fluid too cold, too viscous or too heavy Shaft speed too high Suction line too small, or collapsed Suction line strainer dirty or too small

Continued on Page 4

TROUBLESHOOTING GUIDE

Problem	Possible Cause	Look For
Noisy Pump	Misaligned shaft	Faulty installation Distortion in mounting Axial interference Faulty coupling
	Mechanical fault in pump	Piston and shoe loose or failed Bearing failure Incorrect port plate selection or index Eroded or worn parts in displacement control
Erosion on barrel and port plate	Air in fluid	Refer to above
	Cavitation	Refer to above
High wear in pump	Excessive loads	Reduce speed or pressure setting
	Contaminant particles in fluid	Improper filter maintenance Filter too coarse Dirty fluid introduced to the system Reservoir or breather cap open to atmosphere Improper line replacement
	Improper fluid	Fluid too thick or too thin for operating temperature range Fluid breakdown due to age, temperature or shearing effects Incorrect additives in new fluid Reduced additive effectiveness due to chemical aging
	Improper repair	Incorrect parts, procedures, dimensions or finishes
Pressure shocks	Unwanted water in fluid	Condensation Faulty breather/strainer Heat exchanger leaking Faulty clean-up practice Water in makeup fluid
	Cogging or erratic load movement	Mechanical considerations
	Slow acting relief valve	Replace with fast acting relief valve
	Worn relief valve	Repair or replace, as needed
	Worn compensator	Repair or replace, as needed
Fluid overheats	Insufficient line capacitance (line volume, line stretch, accumulator effects)	Increase line size or length
	Excessive pump leakage	Recheck case drain flow, repair as needed Fluid too thin, minimum operating viscosity 60 SUS (10Cst) Improper assembly
	Faulty relief valve	Set too low (compared to load or compensator) Instability caused by back pressure, or worn parts
	Faulty compensator	Set too high (compared to relief) Worn parts
Faulty heat exchanger	Faulty heat exchanger	Water turned off, or insufficient flow Ambient water temperature too high Fan clogged, restricted or inoperative Mud or scale buildup Intermittent hydraulic fluid flow through exchanger

Continued on Page 5

TROUBLESHOOTING GUIDE (continued)

Problem	Possible Cause	Look For
Fluid overheats (continued)	Faulty reservoir	Fluid level too low Entrained air in fluid Improper, or no baffles Poor air flow, or ambient air temperature too high around reservoir Heat pick up from adjacent equipment
Decrease in set pressure	Loose compensator adjusting screw	Tighten adjusting screw (No.11 in Fig. 14, exploded view)
	Defective function or relief valves	Repair or replace relief valve Check relief valve setting
	Reservoir fluid level too low	Replenish fluid Check drain (below 5% of discharge at rated pressure)
	Deteriorating pump performance	Check pump internal components for wear, repair or replace as needed.
Pressure does not rise	Pump turning backward	Change the rotating direction
	Reservoir fluid level too low	Replenish fluid
	Relief valve or compensator set wrong	Readjust and lock
	Relief valve or compensator defective	Repair or replace
	Clogged suction line	Inspect and clean suction strainers Open gate valve
	Deteriorating pump performance	Check pump internal components for wear, repair or replace as needed.
Insufficient flow	Reservoir fluid level too low	Replenish fluid
	Suction line not sealed	Tighten fittings
	Improper pump stroke control adjustment	Readjust as required Repair or replace as required
	Deteriorating pump performance Worn compensator	Change compensator

PISTON PUMP DISASSEMBLY

Precautions



CAUTION – Before performing any service operation on any pump, be sure that all pressure has been relieved from BOTH SIDES of the system.



CAUTION – Before performing any service operation on any pump, disconnect or lock off power supply.



CAUTION – **Do not attempt to remove the Barrel Spring.** The Barrel Spring is assembled under high compression. Any attempt to remove the Barrel Spring will cause sudden decompression, and may inflict serious personal injury. The Barrel Spring is NOT field serviceable. Should the Barrel Spring require service, the pump must be returned to Continental Hydraulics or an Authorized Repair Center.

1. Please refer to the exploded view (Figure 14 through 17) for proper names and locations of all parts.

2. Pump disassembly for inspection and repair should be undertaken only in the following cases:

Malfunction or leakage due to damage or wear.

When troubleshooting procedures contained in this manual do not solve a problem.

3. Disassembly should be done only as far as necessary to replace or repair worn parts.

4. Perform assembly and disassembly in a clean environment.

5. Avoid dropping, damaging or contaminating the machined parts of the pump and compensator.

6. After disassembly, coat the internal parts with a film of clean oil, and protect them from dirt and moisture.

7. Prior to disassembly, measure and record the length of the protruding part of adjusting screws (22) and (28-11) from Figure 14, and if necessary, (18) from Figure 16 or 17. This will simplify resetting the pump after reassembly.

HPV REPAIR PROCEDURES

DISASSEMBLY, INSPECTION and REASSEMBLY GENERAL

Disassembly in the field by other than an Authorized Repair Center technician, whether for repair or modification will void warranty.



NOTE: Certain steps in this procedure require special tools, and the application of great force. Care should also be taken to contain residual oil during disassembly. Before beginning, read this section through to make sure that you are prepared for the job.

General Disassembly Procedure

1. Drain pump body (1) via Case Drain Ports. (Figure 4)
2. Position the pump with Case Drain Ports up.
3. Remove four compensator screws (71) and then remove remove compensator (28) and O-rings (32).

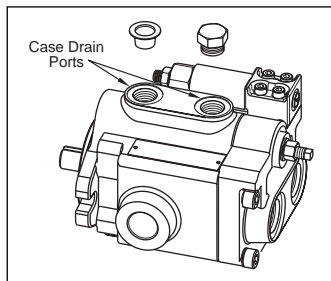

Figure 4

4. Remove four cover retaining screws (46). Loosen two diagonally positioned screws first. Then loosen the remaining two diagonally positioned screws. Remove the screws and carefully separate the cover (2) from the pump body. If the gasket holds the cover in place, tap the cover lightly with a fiber hammer on the side opposite the compensator.

NOTE: The port plate (4) may cling to the cover (2) due to oil film between parts. DO NOT ALLOW THE PLATE TO FALL AND BE DAMAGED.

5. Gently remove the port plate (4) from the barrel (3) face.
6. Place the pump on a work bench with the shaft in a horizontal position. Remove the barrel (3) with piston assembly (5), guide ball (14), guide plate (15), and dowel pins (56) as a unit.
7. Place the barrel (3) on a clean cloth or plastic film. Hold the side of the guide plate (15) and gently remove the piston assembly.
8. Remove the guide ball (14) and dowel pins (56).
9. Place the pump body (1), shaft down, on a fixture designed to keep it from toppling. Protect with a dust-proof plastic film.
10. Place the cover (2) with the assembled guide sleeve (64), plunger (21) and needle bearing (65) on a work bench. The guide sleeve must face up. Protect the parts with a dust-proof plastic film.

NOTE: Following completion of disassembly procedure steps 1 through 10, necessary pump inspection can be performed. Further disassembly may be required if the following inspection steps reveal specific problems.

11-1. When the barrel (3) is laid flat, the dowel pins (56) must protrude slightly. If otherwise, or if the dowel pins are easily pushed in, replace the barrel.

11-2. If the hanger (9) has little or no inclination against the shaft (8), or if it can easily be moved by hand, go to steps 12 through 15.

11-3. If shaft seal leakage or excessive ball-bearing play is apparent, go to steps 16 through 21.

11-4. If compensator function is erratic, go to steps 23 through 33, as required.

Hanger Removal

12. Place the pump body in a large vise, or on a working surface adapted to hold the pump body firmly.
13. Remove the trunnions (10) using the blind threaded holes, and the appropriate trunnion removal tool. See Figure 9 on page 13 for trunnion removal tool specifications.



CAUTION: The hanger may be under tension, and should be secured to prevent injury.

14. Remove the hanger (9), spring seat (20), and spring (19) in this order.

15. Proceed to HANGER INSPECTION and TRUNNION INSPECTION, page 9.

Shaft Removal and Disassembly

16. As required, remove the key (70). Tap gently at the end of the key with a hammer or chisel if it is difficult to remove.
17. Remove the retaining ring (41) with a snap ring pliers.
18. Remove the shaft (8). Pull the shaft toward the cover. Tap lightly with a fiber hammer on the end of the shaft if it is difficult to remove.
19. Replace the ball-bearing if it shows excessive wear, or if noise is heard when rotating the outer race by hand.
20. To replace the ball bearing, remove retaining rings (68), and remove the ball bearing (69) with a hand press or by light hammering.
21. If oil leaks are observed, the shaft seal must be replaced. Remove the shaft seal (38) from the pump body (1). Use a push rod of smaller diameter than the outside diameter of the shaft seal.

NOTE: Do not reuse seals. See Parts List, page 17, Item 38 for replacement part numbers.

22. Proceed to SHAFT INSPECTION, page 9, and BALL BEARING INSPECTION, page 11.

Compensator Disassembly

23. Loosen the hex nut (28-12) and remove the adjusting screw (28-11) from the end cap (28-3).
24. Remove the end cap (28-3).
25. Remove the spring (28-6) and spring seat (28-5).
26. Remove the spool (28-2).

Continue for Codes 7, 19, and 26 compensators. Item numbers refer to figures 16 and 17, page 20.

27. Loosen the hex nut (12) and remove the adjusting screw (18) from the body (1).
28. Remove the spring (7) and cone (16).
29. Proceed to PRESSURE COMPENSATOR INSPECTION, page 11.

HPV REPAIR PROCEDURES (continued)

NOTE: If the cone is badly worn or damaged, perform the following steps.

30. For Code 7 or 19 compensators, remove the plug (20). Using a rod, tap the seat (15) out from the opposite end.

31. For Code 26 compensators, remove the fitting (27) and adjusting screw (18) as an assembly.

32. Remove the dowel pin (24) and ball (17).

33. Remove the fitting (29). Using a rod, tap the seat (15) out from the opposite end.

Rework Limits for Wear Parts

Barrel Bores – Measure each bore in four places, including one place deep within the bore, where the piston doesn't run. Replace the barrel if the difference in measurements exceeds .0004 in. or .010 mm.

Barrel Face – May be lapped no more than .0002 in. or .005 mm measured by before and after depths of oil grooves on barrel face.

Pistons (5) – Measure each piston in four places, including one at the shoe end, where the piston doesn't enter the barrel. Replace Piston if the difference in measurements exceeds .0006 in. or .015 mm.

Shoe, Piston Assembly – Replace assemblies if end play exceeds .003 in. or .076 mm.

Shoe, Face – May be lapped up to .004 in. or .102 mm. The difference in shoe flange thickness between the thinnest and thickest of nine shoes should not exceed .0012 in. or .03 mm.

Port Plate (4) – May be lapped .006 in. or .152 mm. Maintain flatness of .0002 in. or .005 mm.

Wear Plate (16) – Do not lap. Replace if there are any indications of wear or bending.

Guide Plate (15) – Do not lap. Measure thickness at several places. Replace if thickness varies more than .004 in. or .102 mm.

INSPECTION PROCEDURES

Part (Item No.)	Inspection Procedure	Corrective Action
Pump Body (1)	Check for cracks around tapped holes. Check for cracks around retainer ring groove. Perform dye penetrant or magnetic particle inspection over entire housing when oil leakage is observed.	Replace if cracked.
Cover (2)	Visually inspect for obvious defects Check for excessive wear in guide sleeve (64). Axial scratches should not be detectable with a fingernail. Diameter difference must not exceed .001 in. or .025 mm when measured at several random points. Check for excessive play between drive shaft (8) and needle bearing (65). (Maximum radial play is .003 in. or .076 mm.)	Replace if defective
Barrel (3)	Visually inspect the barrel face for uniform minute concentric nicks.	Repair by lapping until scratches are removed. Do not exceed rework limits listed above.
	Visually inspect for deep, localized nicks.	Replace barrel. Flush reservoir and circuit.
	Visually inspect for signs of seizure, scoring or discoloration.	Replace barrel. Check for correct hydraulic fluid type, temperature rise, excessive pressure. Correct as needed.

Continued on Page 8

INSPECTION PROCEDURES Continued

Part (Item No.)	Inspection Procedure	Corrective Action
<p>Barrel (3) (Continued)</p>	<p>Visually inspect the bores' internal condition for the following</p> <ul style="list-style-type: none"> A. Localized polishing at edge. B. Minute, longitudinal nicks. C. Localized longitudinal nicks. <p>D. Localized seizure, scoring, discoloration</p>	<ul style="list-style-type: none"> A. Re-use as is. B. Re-use as is. C. Replace part. Flush reservoir and circuit. D. Replace barrel and all piston and shoe assemblies (5). Check for correct hydraulic fluid type, temperature rise, excessive pressure. Correct as needed.
	<p>Inspect for bore wear as follows. Wash the barrel bore. Insert a piston completely into a bore. Cover the kidney-shaped hole in the barrel, and the center hole on the shoe. Withdraw the piston.</p>	<p>If no resistance, replace the barrel and piston assemblies. If there is resistance the bore is reusable.</p>
	<p>Measure each bore in four places, including one place deep within the bore, where the piston doesn't run.</p>	<p>Replace the barrel if the difference in measurements exceeds .0004 in. or .010 mm.</p>
<p>Port Plate (4)</p>	<p>Visually inspect the surface for uniform minute concentric scratches, or deep scratches on the plate.</p>	<p>Repair by lapping until scratch is removed. Do not remove more than .006 in. or .152 mm. Maintain flatness of .0002 in. or .005 mm.</p>
	<p>Visually inspect for heat discoloration</p>	<p>Use as is. Lap if excessively discolored. Do not remove more than .006 in. or .152 mm</p>
	<p>Inspect for cavitation erosion between ports</p>	<p>Repair by lapping until erosion is removed. Do not remove more than .006 in. or .152 mm.</p>
<p>Piston Assembly (5)</p>	<p>Inspect for shoe end play by pushing and pulling the shoe while holding the piston. If the shoe clicks, or if movement can be seen, the piston assembly is excessively worn.</p>	<p>Replace piston assemblies as a set. Check circuit suction pressure. If less than -5 in. Hg., raise fluid level in reservoir, clean intake strainer and/or correct faulty circuit design.</p>
	<p>Visually inspect shoe face for localized polishing, or random radial marks.</p>	<p>Repair by lapping assemblies as a set. Shoes may be lapped up to .004 in. or .102 mm. Difference in shoe flange thickness between the thinnest and thickest of nine shoes should not exceed .0012 in. or .03 mm. Check circuit suction pressure. If less than -5 in. Hg., raise fluid level in reservoir, clean intake strainer and/or correct faulty circuit design.</p>

INSPECTION PROCEDURES (Continued)

Part (Item No.)	Inspection Procedure	Corrective Action
Piston Assembly (5) (Continued)	Visually inspect the shoe flange for burrs or rolled edges	If slight, repair by lapping. If severe, replace part.
	Inspect the piston outer diameter. Measure each piston in four places, including one at the shoe end, where the piston doesn't enter the barrel.	Replace Piston if the difference in measurements exceeds .0006 in. or .015 mm.
	Visually inspect for slight discoloration or cross hatch trace.	Reuse as is.
	Visually inspect for localized scratch marks running in a longitudinal direction.	Replace pistons as a set. Flush reservoir and circuit.
	Visually inspect for signs of seizure, scoring or discoloration	Replace piston and shoe assemblies (5). Replace barrel (3). Check for correct hydraulic fluid type, temperature rise, excessive pressure. Correct as needed.
Shaft (8)	Visually inspect the shaft end outer surface. A. If burnt brown spots are apparent over entire surface B. If uneven wear on key side surface	A. Remove with emery paper. B. Check fit to coupling hub. If loose, replace.
	Inspect for pitting or corrosion over all or part of shaft surface.	Replace shaft. Check fit to coupling hub Check alignment between prime mover and pump. Correct as needed.
	Visually inspect shaft seal surface for: A. Seal contact marks. B. Bright polish C. Contact marks over 0.04 in. or 1 mm wide, can be felt with fingernail.	A. Use as is. B. Use as is. C. Replace shaft. Inspect and replace shaft seal as needed.
	Visually inspect key groove bottom end for cracks. If in doubt, check with dye penetrant or magnetic particle inspection.	If cracked, replace shaft. Check alignment with prime mover. Correct as needed.
	Inspect needle bearing rolling contact surfaces for wear.	Replace shaft if difference between bearing contact and non-contact surfaces is more than .0008 in. or .020 mm
Hanger (9)	Visually inspect the trunnion bore. Contact surface not excessively worn Contact surface shows obvious wear, uneven contact or localized nicks.	Reuse hanger as is. Replace the hanger when inside diameter difference is directionally more than .0008 in. or .020 mm.
	Visually inspect contact surface with the plunger (21). Wear marks up to 0.2 in. or 5 mm wide. Wear marks over 0.2 in. or 5 mm wide.	Reuse hanger as is. Replace hanger. Adjust volume as needed.
Trunnion (10)	Visually inspect contact surface to hanger (9). Very slight wear. Localized seizure, scoring, discoloration.	Reuse trunnion as is. Replace the trunnion. Also replace hanger (9). Check hydraulic fluid type, temperature rise, excessive pressure.

INSPECTION PROCEDURES (Continued)

Part (Item No.)	Inspection Procedure	Corrective Action
Key (70)	Inspect for wear on side surface. A. Discoloration. B. Stepped wear.	A. Remove discoloration with emery cloth. Reuse key. B. Replace key if worn over .0002 in. or .005 mm. When coupling hub-to-shaft fit is loose, replace the coupling. Recheck alignment with prime mover. Check for excessive pressure or side load. Correct as needed.
Guide Plate (15)	Visually inspect contact surface between guide plate and piston shoe. If brightly polished,	Re-use as is.
Wear Plate (16)	Inspect contact surface for indentations. If stepped or indented, Check face condition for: A. Polish over all or part of the surface B. Scratches, wear or metal transfer	Replace guide plate. A. Re-use as is. B. Replace wear plate. Flush reservoir and circuit. Check hydraulic fluid type, temperature rise, and excessive pressure. Correct as needed.
Spring (18)	Measure free heights. Correct heights are: A. HPV-6: 1.36" or 34.5 mm B HPV-10: 1.57" or 40 mm C. HPV-15: 1.79" or 45.5 mm D. HPV-20: 1.97" or 50 mm E. HPV-29: 2.05" or 52 mm	Replace when height is decreased more than 5% from the given heights.
Spring (19)	Measure free height. Correct heights are: A. HPV-6: 2.44" or 62 mm B HPV-10: 2.60" or 66 mm C. HPV-15: 3.00" or 76 mm D. HPV-20: 3.00" or 76 mm E. HPV-29: 3.19" or 81 mm	Replace when height is decreased more than 3% from the given heights.
Plunger (21)	Inspect contact pattern on spherical surface. A. Wear pattern less than 0.2 in. or 5 mm wide B. Wear pattern over 0.2 in. or 5 mm wide	A. Re-use as is. B. Replace plunger. In case of rapid wear, check hydraulic fluid type, temperature rise, and excessive pressure. Correct as needed.
Guide Sleeve (64)	Inspect outer surface contact condition. A. Slight uneven wear on one side, partial polishing. B. Distinct localized contact, with strong, bright polishing.	A. Re-use as is. B. Replace guide sleeve and cover (2).
	Measure guide sleeve outside diameter at several points.	If the difference is more than .0008 in. or .020 mm replace guide sleeve and cover (2). Check fluid type, temperature rise, and pressure. Correct as needed.
	Visually inspect for signs of seizure, scoring, or discoloration.	Replace guide sleeve and cover (2). Check hydraulic fluid type, temperature rise, and excessive pressure. Correct as needed.

INSPECTION PROCEDURES (Continued)

Part (Item No.)	Inspection Procedure	Corrective Action
Ball Bearing (69)	Inspect for radial play or sticking. Rotate outer race by hand.	Replace ball bearing if excessive play or sticking is felt, or if unusual noise is heard. Replace if obvious discoloration or pitting are observed.
Needle Bearing (65)	Visually inspect rolling surfaces.	Replace if obvious discoloration or pitting are observed.
Gasket (24)		Replace whenever pump is disassembled.
Shaft Seal (38)		Replace whenever shaft is removed from pump.
Thread Seal (54)	Visually inspect for damage.	Replace thread seal as needed.

ASSEMBLY TOOLS

Shaft Seal Installation Tool

Series		A*	B	C†	D	E	F
HPV-6	In. (mm)	1.75 (44.5)	2.17 (55.1)	.185 (4.7)	5.0 (127)	1.25 (31.75)	.79 (20.1)
HPV-10	In. (mm)	1.75 (44.5)	2.17 (55.1)	.185 (4.7)	5.0 (127)	1.25 (31.75)	.79 (20.1)
HPV-15	In. (mm)	1.95 (49.5)	2.36 (59.9)	.197 (5.0)	5.0 (127)	1.25 (31.75)	.79 (20.1)
HPV-20	In. (mm)	2.15 (54.6)	2.56 (65.0)	.204 (5.2)	5.0 (127)	1.25 (31.75)	.79 (20.1)
HPV-29	In. (mm)	2.15 (54.6)	2.56 (65.0)	.204 (5.2)	5.0 (127)	1.25 (31.75)	.79 (20.1)

Material: Steel

* $\pm .008$ in. ($\pm .203$ mm)

† $\frac{+.0 \text{ in. } (+.0 \text{ mm})}{-.008 \text{ in. } (-.203 \text{ mm})}$

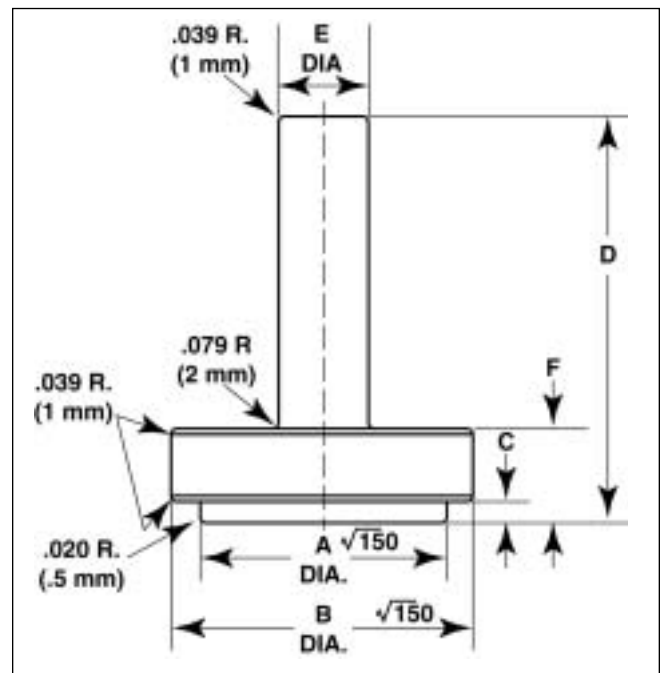

Figure 5 (not to scale)

ASSEMBLY TOOLS (continued)

Ball Bearing Installation Tool

Series		A	B*	C	D
HPV-6	In. (mm)	2.36 (59.9)	2.08 (52.8)	1.02 (25.9)	4.33 (110)
HPV-10	In. (mm)	2.76 (70.1)	2.44 (62.0)	1.02 (25.9)	4.52 (114.8)
HPV-15	In. (mm)	3.15 (80.0)	2.83 (71.9)	1.22 (31.0)	5.19 (131.8)
HPV-20	In. (mm)	3.54 (89.9)	3.15 (80.0)	1.42 (36.0)	6.30 (160.0)
HPV-29	In. (mm)	3.54 (89.9)	3.15 (80.0)	1.42 (36.0)	6.30 (160.0)

Material: Steel

* $\frac{+.012 \text{ in. } (+.305 \text{ mm})}{-.004 \text{ in. } (-.102 \text{ mm})}$

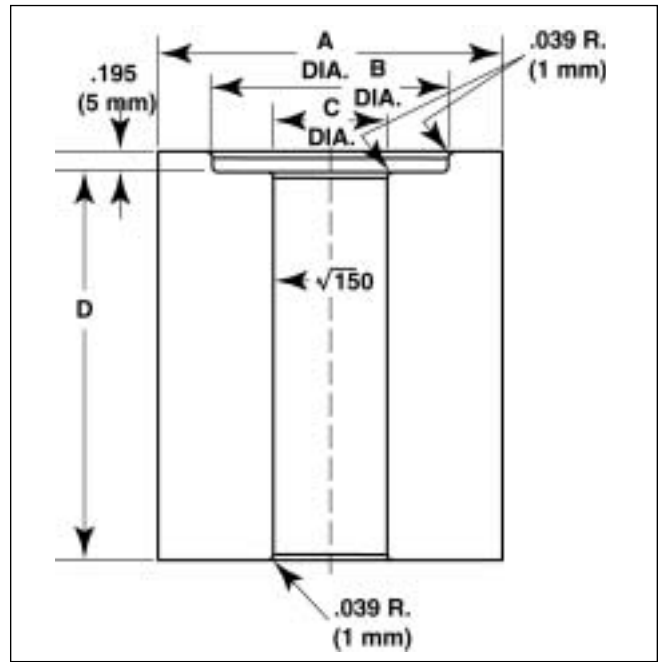

Figure 6 (not to scale)

Protective Cone

Series		A*	B†	C	D	E
HPV-6	In. (mm)	1.00 (25.4)	0.75 (19.1)	2.24 (56.9)	1.65 (41.9)	1.57 (39.9)
HPV-10	In. (mm)	1.00 (25.4)	0.875 (22.2)	2.68 (68.1)	2.08 (52.8)	2.00 (50.8)
HPV-15	In. (mm)	1.20 (30.5)	0.875 (22.2)	2.68 (68.1)	2.08 (52.8)	2.00 (50.8)
HPV-20	In. (mm)	1.40 (35.6)	1.25 (31.8)	2.68 (68.1)	2.08 (52.8)	2.00 (50.8)
HPV-29	In. (mm)	1.40 (35.6)	1.25 (31.8)	2.68 (68.1)	2.08 (52.8)	2.00 (50.8)

Material: Teflon preferred, or steel heat treated to Rc40 or Rc45, and chromium plated.

*± .004 in. (± .102 mm)

† $\frac{+.008 \text{ in. } (+.203 \text{ mm})}{-.004 \text{ in. } (-.102 \text{ mm})}$

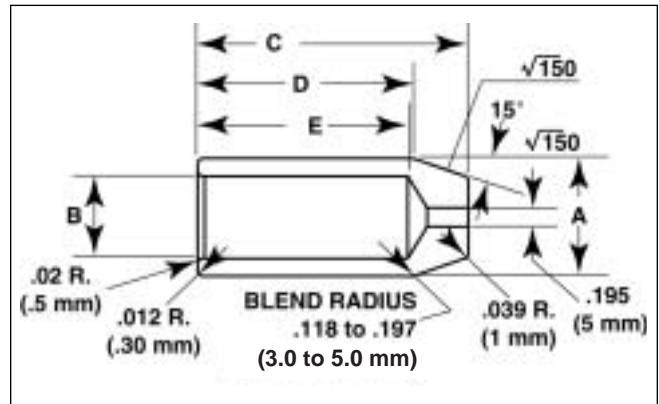

Figure 7 (not to scale)

Trunnion Assembly Tool

Series		A	B	C
HPV-6	In. (mm)	1.75 (44.45)	.997/.996 (25.32/25.30)	1/2-13 UNC X 3/4 DP
HPV-10	In. (mm)	1.75 (44.45)	.997/.996 (25.32/25.30)	1/2-13 UNC X 3/4 DP
HPV-15	In. (mm)	2.00 (50.80)	1.247/1.246 (31.67/31.65)	3/4-10 UNC X 1 DP
HPV-20	In. (mm)	2.25 (57.15)	1.497/1.496 (38.02/38.00)	3/4-10 UNC X 1 DP
HPV-29	In. (mm)	2.25 (57.15)	1.497/1.496 (38.02/38.00)	3/4-10 UNC X 1 DP

Material: Steel, or rework trunnion to B diameter.

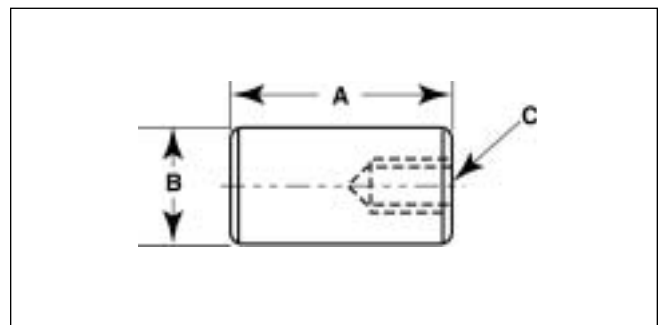

Figure 8 (not to scale)

ASSEMBLY TOOLS (continued)

Trunnion Removal Tool

Series		A	B DIA.	C DIA.	D	E THD.	F DIA.
HPV-6 HPV-10	In. (mm)	1.75 (44.5)	1.50 (38.1)	.56 (14.2)	4.25 (108)	1/2-13	2.50 (63.5)
HPV-15	In. (mm)	2.00 (50.8)	1.75 (44.5)	.81 (20.6)	4.50 (114)	3/4-10	2.75 (69.8)
HPV-20 HPV-29	In. (mm)	2.25 (57.15)	2.00 (50.8)	.81 (20.6)	4.75 (121)	3/4-10	3.00 (76.2)

Material:

- Item Material
- (1) Sleeve Steel
- (2) Spacer Steel
- (3) Nut Hardened Steel GR.5
- (4) All-Thread Rod Hardened Steel GR.5

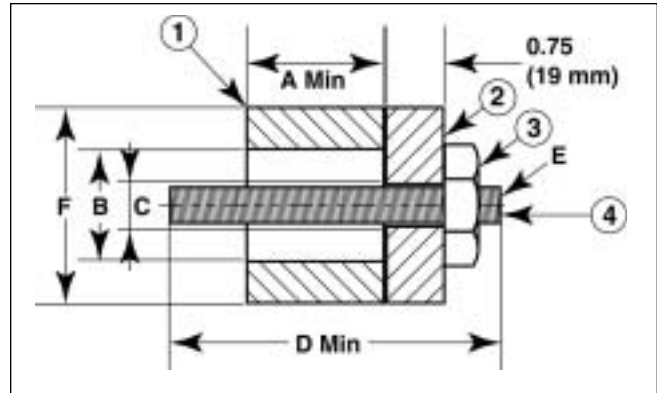

Figure 9 (not to scale)

ASSEMBLY PROCEDURES

Pump Assembly

Piston Pump assembly must be done more carefully than disassembly. The working environment must be clean. All parts must be clean and inspected for wear or damage in accordance with the Inspection Procedures listed on pages 7 through 11.

1. Compare the disassembled parts with the exploded view shown in Fig. 14 or 15 on page 20 for missing parts or irregularities.
2. Inspect retaining rings. Replace if deformed.
3. Place the pump body (1) in a press, with the mounting flange facing up.
4. Apply grease between the lips of the shaft seal. Grease should not protrude above the tip of the lip, and should fill approximately 80% of the space.
5. Use a press, and the tool shown in Fig. 5 on page 11, slowly force the shaft seal into the pump body (1) until seated.
6. Assemble a retaining ring (68) on the shaft end. The sharp edge of the retaining ring must always be facing away from the part being retained.
7. Using the ball bearing installation tool shown in Fig. 6 on page 12, press the ball bearing (69) onto the shaft. Do not exceed the maximum pressing force guidelines listed as follows.
8. Install the remaining retaining ring (68).

Series	Bearing Part No	Pressing Force	
		Lbs.	N
HPV-6	258191	1330	5900
HPV10	258192	1500	6700
HPV10	258193	1690	7500
HPV10	258194	2200	9800
HPV10	258194	2200	9800

9. Rotate the bearing manually to check for unusual noise or binding.
10. Fit the protective cone shown in Fig. 7 on page 12 over the end of the shaft. Apply a light coating of lithium grease to the outer surface of the cone. Slide the protective cone and shaft through the shaft seal, positioning the ball bearing in place.
11. Assemble the retaining ring (41) into the pump body.
12. Place the housing on a fixture with the shaft end facing down. Insert the spring (19) and spring seat (20) into the pump body.
13. Lightly coat the wear plate (16) with grease, and mate to the hanger (9). Then fit into the pump body.
14. Press the hanger (9) until approximately horizontal, using a press if necessary. Then install the trunnions.



NOTE: A used trunnion shaft, turned down to a slip fit simplifies hanger installation. Slip the modified trunnion into one side to hold it in place while the working trunnion is press-fit into the opposite side. See Fig. 8, page 12 for trunnion assembly tool specifications.

15. Lightly coat the trunnions with teflon-based sealing paste. Avoid putting sealing paste on the section of the trunnion that will be held in the hanger. Press them through the pump body, and into the hanger.



NOTE: Be certain the hanger bores are correctly aligned with the pump body. After the trunnions have been installed, confirm that the hanger moves freely on them.

PUMP ASSEMBLY (continued)

16. Place the barrel (3) on a clean working surface. Insert the washers (27) and spring (18) into the center hole. The washers (27) should be located on both ends of the spring.

17. Compress the spring (18) using a mechanical press. Secure the spring with the retaining ring (40).

18. Place the barrel (3) on a clean sheet of paper or cloth. Insert the three dowels (56) into the holes located outside of the spline hole. Place the guide ball (14) on top.

19. Compress manually, and confirm spring(18) force.

20. Hold the guide plate (15) horizontal with one hand, and insert the nine piston assemblies (5) into the guide plate bores. The piston shoes should move freely on the pistons.

21. Support the guide plate horizontally, and insert the piston assemblies (5) into the barrel bores (3).

22. Place the pump body (1) so that the shaft (8) is horizontal. Assemble the barrel (3), piston assemblies (5), guide ball (14) and guide plate (15) together onto the shaft.



CAUTION: Do not force the shaft spline into the barrel groove. Carefully rotate the parts, and apply slight pressure to work them together. Assembly is correct

when the edge of the barrel is approximately .25 in. below the edge of the pump body.

23. Place the pump body (with shaft end pointing down) on a fixture, and coat the face of the barrel with clean hydraulic fluid. Place the gasket (24) on the pump body.

24. Assemble the plunger (21) and port plate (4) onto the cover (2).

25. Lightly coat the port plate (4) with grease. Place the port plate on the cover (2), locating the "U" shaped slot over the pin (66). See Fig. 10

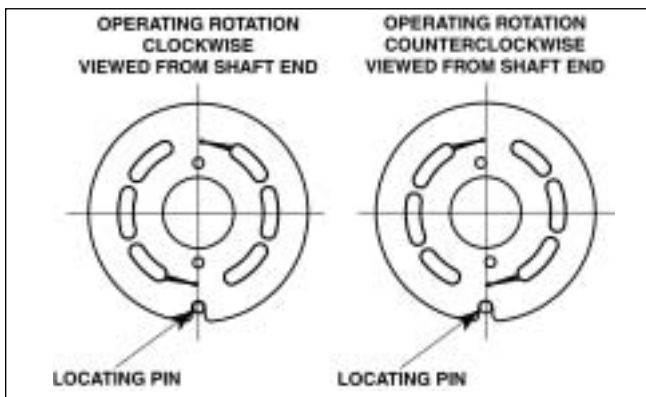

Figure 10

26. Hold the cover so the plunger (21) does not fall off. Then carefully place the cover on the pump body.

27. Secure the cover (2) with socket head screws (46), tightened diagonally. The final tightening torque should be as follows:

Series	N - m		Lbs. - Ft.	
	Min.	Max	Min.	Max
HPV-6	5.4	6.9	4.0	5.1
HPV-10	7.8	9.8	5.8	7.3
HPV-15	21.6	25.5	16.0	18.9
HPV-20	39.2	43.1	29.0	31.9
HPV-29	39.2	43.1	29.0	31.9

28. Attach rebuilt pressure compensator to pump cover (2). Pressure compensator assembly procedures are listed below, and on the next page.

29. Install the thread seal (54) and hex nut (45) on the adjusting screw (22), then screw into the hole in the pump cover (2). Finger tighten until the adjusting screw bottoms against the plunger. Adjust to desired volume.

Series	No. of Turns Full to Zero Vol.
HPV-6	8.5
HPV-10	8.5
HPV-15	8.5
HPV-20	9.7
HPV-29	10.5

30. Using a lever or hub, rotate the shaft several times in the direction indicated by the arrow on the escutcheon plate (61). Confirm that the pump rotates freely and smoothly.

31. With the palm of your hand, cover the port on the side on which the compensator is mounted. Rotate the input shaft. If air is forced out of the piping port, the pump is working properly.

32. Screw the case drain plug (58) into the pump body. Seal other openings with plastic cap seals.

33. Clean the outside of the pump, and re-install onto the original equipment. If the pump will be stored before re-installation, coat all unpainted surfaces with a light coating of oil, and store in a sealed plastic bag.

STANDARD PRESSURE COMPENSATOR CONTROL (28) ASSEMBLY

1. Carefully clean the compensator body (28-1) and spool (28-2). Soak in clean hydraulic fluid.

2. Check O-rings (28-8) and (28-9) for deformation or wear. Replace as needed. Assemble O-ring (28-8) to cap (28-3). Assemble O-ring (28-9) to spring seat (28-4).

3. Carefully insert the spool (28-2) into the compensator body (28-1).

4. Fit the spring seats (28-4) and (28-5) onto both ends of the spring (28-6). Assemble into the compensator body.

5. With the adjusting screw (28-11) and nut (28-12) set on the cap, place the cap on the spring seat (28-4), and screw into the threaded hole in the compensator body. Tighten until the edge surface is flush. **Screw (28-11) adjustment rate approximately 650 psi (45 bar) per turn.**

PUMP ASSEMBLY (continued)

6. Check O-rings (32) for deformation and wear. Replace as needed. Install the O-rings.

REMOTE PRESSURE (Code 7), AND LOAD SENSING CONTROL (Code 19) ASSEMBLY
See Figure 16

1. For initial assembly, follow steps 1 through 5 of the Standard Pressure Compensator Assembly listed above. For Load Sensing Control (Code 19) only, install the pin (28-24) into the spool.
2. To install the seat (28-15), insert the open end into the bore, and press into place. Install plug (28-20) and tighten.
3. Fit the washer (28-23) and spring (28-7) onto the adjusting screw (28-18). Fit the cone (28-16) into the spring, and assemble into the body.
4. Set the adjusting screw to the measurement taken at disassembly, and lock into place with nut (28-12). Cover with acorn nut (28-22).
5. Install the O-rings (32). Assemble the compensator to the pump cover.

HORSEPOWER LIMITING CONTROL (Code 26) ASSEMBLY
See Figure 17

1. For initial assembly, follow steps 1 through 5 of the Standard Pressure Compensator Assembly listed above.
2. To install the seat (26-15), insert the open end into the bore, and press into place. Install plug (26-20) and tighten.
3. Fit the washer (26-23) and spring (26-7) onto the adjusting screw (26-18). Fit the cone (26-16) into the spring, and assemble into the body.
4. Set the adjusting screw to the measurement taken at disassembly, and lock into place with nut (26-12). Cover with acorn nut (26-22).
5. Place the ball (26-17) into the body, atop the orifice.
6. Insert the pin (26-24) into the fitting assembly (26-27), and tighten in the valve body.
7. Install O-ring (26-21) onto the fitting (26-29) and screw into the compensator.
8. Install the O-rings (32). Assemble the compensator to the pump cover.

TEST PROCEDURES AND SPECIFICATIONS

Pump Performance Test

1. With the operating speed at 1750 ± 35 rpm, record delivery flow rate, drain flow rate, and fluid temperature at minimum outlet pressure and maximum rated continuous pressure.

Series	Max. Rated Continuous Pressure
HPV-6	3500 PSI (241 bar)
HPV-10	3500 PSI (241 bar)
HPV-15	3500 PSI (241 bar)
HPV-20	3500 PSI (241 bar)
HPV-29	3000 PSI (207 bar)

2. Rate of flow at minimum outlet pressure, and maximum rated continuous pressure should fall within the following range:

Series	Flow Rate At: GPM (lpm)	
	At Minimum Outlet Pressure	At Rated Continuous Pressure
HPV-6	6.0-7.1 (22.7-26.9)	5.9 Min. (22.3)
HPV-10	9.5-10.3 (36.0-39.0)	8.7 Min. (32.9)
HPV-15	15.0-16.6 (56.8-62.8)	14.4 Min. (54.5)
HPV-20	20.0-21.4 (75.7-81.0)	18.6 Min. (70.4)
HPV-29	28.0-30.4 (106.0-115.1)	26.6 Min. (100.7)

3. Case Drain flow at maximum rated continuous pressure and zero flow is as follows:

Series	Case Drain Flow at Zero Flow
HPV-6	.93 GPM (3.5 lpm) Max.
HPV-10	.98 GPM (3.7 lpm) Max.
HPV-15	1.06 GPM (4.0 lpm) Max.
HPV-20	1.60 GPM (6.1 lpm) Max.
HPV-29	1.90 GPM (7.2 lpm) Max.

Pressure Compensator Test

Control Option Adjustment Procedures - Standard Compensator

1. With a pump running at deadhead (no-flow), adjust the compensator pressure to **3500 ± 35 PSI (241 ± 2.5 bar)**.

2. The following flow rates should be achieved:

Series	Flow Rate, GPM (lpm)	
	Pressure, PSI (bar)	Flow, GPM (LPM)
HPV-6	3325 (229.3)	5.9 (22.3) Min.
HPV-10	3325 (229.3)	8.7 (32.9) Min.
HPV-15	3325 (229.3)	14.4 (54.5) Min.
HPV-20	3325 (229.3)	18.6 (70.4) Min.
HPV-29	2850 (196.5)	26.6 (100.7) Min.

3. The pump shall return to a stable condition, with no loss of control, within one (1) second after being cycled from full flow to zero flow.

4. Cycle the pump from zero flow to full flow to zero flow. The zero pressures shall not vary more than ±30 psi (2 bar).

PUMP ASSEMBLY (continued)

5. The pressure ripples at zero flow and partial flow shall not exceed ± 50 psi (3.5 bar).
6. Case drain flow shall be stable.

Control Option Adjustment Procedures - Remote Compensator

1. Be sure the pin (24) is not in the compensator spool. See Figure 16.
2. Attach a vent line, with needle valve, into the vent line, between the compensator and tank.

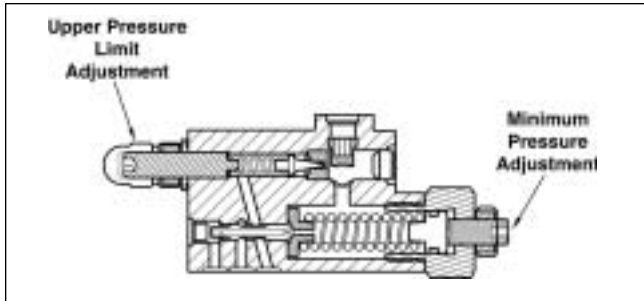

Figure 11

3. Close the valve in the vent line.
4. Start the pump and adjust the load to deadhead (no flow). If there is a check valve installed before the pressure gauge, allow some flow in the circuit (up to 10% of full flow).
5. Open the vent valve, and set the "minimum pressure adjustment screw" (see Fig. 11) to 250 ± 25 psi (17 ± 1.7 bar).
6. Close the vent valve. Set the "upper pressure limit adjustment" to the maximum desired compensator setting. See Figure 11 for adjuster location.
7. Open and close the vent port several times. When the valve is open, discharge pressure should drop to the differential setting of 250 ± 25 psi (17 ± 1.7 bar). When it is closed, discharge pressure should go to the maximum compensator setting. Cycle the pump from deadhead to full flow with the compensator vented or unvented.
8. If flow is within accepted limits, and no leaks are detected, remove the needle valve from the vent port.
9. The pump is now ready for remote control.

Control Option Adjustment Procedures - Load Sensing Compensator

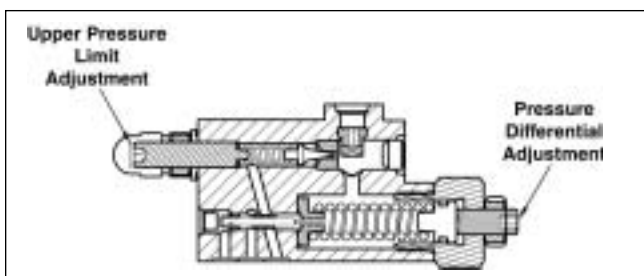

Figure 12

1. Make sure the pin (24, Fig. 16) is in the compensator spool.
2. Install a sense line between the load valve and the speed valve.
3. Open the load valve.
4. Back the upper pressure limit adjustment screw out two (2) turns. (Fig. 12, page 16)
5. Using a speed valve, adjust the pump to zero flow (deadhead). Note: if there is a check valve installed before the pressure gauge, allow some flow in the circuit (up to 10% of full flow).
6. Adjust the pressure differential adjustment screw to $\Delta 250 \pm 25$ psi (17 ± 1.7 bar). (Fig. 12)
7. Using the speed valve, adjust the pump to partial flow (25-50% of full flow).
8. Close the load valve.
9. Set the upper pressure limit adjustment to the desired compensator setting.
10. Open and close the load valve several times. When the load valve is open, discharge pressure should drop down to the pressure differential setting of $\Delta 250 \pm 25$ psi (17 ± 1.7 bar). When the load valve is closed, discharged pressure should go to the maximum compensator setting.
11. Using the load valve, adjust the discharge pressure from 500 psi (34.5 bar) to 2500 psi (172.4 bar). The differential pressure should be at $\Delta 250 \pm 25$ psi (17 ± 1.7 bar) throughout the range.
12. Using the speed valve, cycle the pump from zero flow (deadhead) to full flow.
13. If flow is within accepted limits, and no leaks are detected, the compensator is ready for operation.

Control Option Adjustment Procedures - Horse Power Limiting Compensator

1. Be sure the proper orifice is installed in the pump discharge port.
2. Install the sense line into the circuit.

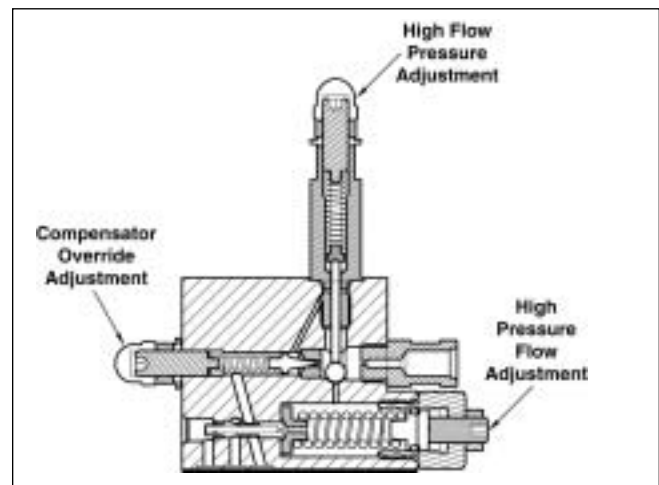

Figure 13

3. Using the High Pressure Flow Adjustment (Fig. 13), preload the spring.
4. Back out the High Flow Pressure Adjustment (Fig. 13) until there is no resistance.
5. Start the pump.
6. Using the Compensator Override Adjustment (Fig. 13), set the compensator 500 psi (34.5 bar) above the desired pressure (P1). Note: if the pump is not at zero flow, adjust the relief valve until zero flow is achieved.
7. Adjust the relief valve to the desired pressure (P1).
8. Adjust the High Pressure Flow Adjustment (Fig. 13) to achieve full flow at 95% of the desired pressure (P1). Note: if the discharge pressure drops below the desired value, readjust it using the relief valve.
9. Adjust the relief valve to the desired pressure (P1) plus 1/2 turn.
10. Using the Compensator Override Adjustment, set the pump at the desired pressure (P1). Note: the pump should be at zero flow.
11. Adjust the pump to the desired flow (F2). At the same time, use the High Flow Pressure Adjustment to set the discharge pressure to the corresponding full flow pressure (P2).
12. Check the flow at 95% of P1. If it is not as desired, adjust it by using the High Flow Pressure Adjustment.

STANDARD SETTINGS

Series	HP	P1	P2	F1	F2
HPV-6	8	3500 PSI	1700 PSI	2.4 GPM	5.9 GPM
HPV-10	12	3500 PSI	1700 PSI	4.0 GPM	8.7 GPM
HPV-15	19	3500 PSI	1700 PSI	6.0 GPM	14.4 GPM
HPV-20	24	3500 PSI	1700 PSI	8.0 GPM	18.6 GPM
HPV-29	29	3000 PSI	1700 PSI	13.0 GPM	26.6 GPM

13. Adjust system pressure from high pressure to low pressure while observing HP draw. If draw is not as desired, repeat steps 10 and 11.
14. If HP draw is within accepted limits, and no leaks are detected, the compensator is ready for operation.

PART AND ASSEMBLY IDENTIFICATION

The following chart, and Figures 14 - 17 may be used to identify individual parts and assemblies in Piston Pumps.

PARTS LIST

	DESCRIPTION	QTY	HPV-6	HPV-10	HPV-15	HPV-20	HPV-29	
1	Pump Body	1	550745 SAE 550748 BSPP	550750 SAE 550749 BSPP	550754 SAE 550756 BSPP	550759 SAE 550757 BSPP	550764 SAE 550758 BSPP	
2	Cover, Rear Port - RH Kit	1	260293 SAE BSPP-Con. CHD	260294 SAE BSPP-Con. CHD	260295 SAE BSPP-Con. CHD	260296 SAE BSPP-Con. CHD	260297 SAE BSPP-Con. CHD	
	Cover, Rear Port - LH Kit		261191 SAE BSPP-Con. CHD	261192 SAE BSPP-Con. CHD	261193 SAE BSPP-Con. CHD	261194 SAE BSPP-Con. CHD	261195 SAE BSPP-Con. CHD	
	Cover, Side Port - RH Kit		261774 SAE BSPP-Con. CHD	261776 SAE BSPP-Con. CHD	261778 SAE BSPP-Con. CHD	261780	261782	
	Cover, Side Port - LH Kit		261775 SAE BSPP-Con. CHD	261777 SAE BSPP-Con. CHD	261779 SAE BSPP-Con. CHD	261781	261783	
	Cover, Tandem - RH Kit		N/A	SAE-Con. CHD BSPP-Con. CHD	SAE-Con. CHD BSPP-Con. CHD	Contact CHD	264609	
	Cover, Tandem - LH Kit		N/A	SAE-Con. CHD BSPP-Con. CHD	SAE-Con. CHD BSPP-Con. CHD	Contact CHD	264325	
3	Barrel	1	552078	550876	552035	552021	550868	
4	Port Plate - RH	1	550910	550877	550898	550897	550867	
	Port Plate - LH		552041	550939	550962	550947	550927	
5	Piston and Shoe Ass'y.	9	258093	258094	258095	258096	258097	
8	Keyed Shaft	1	550766	550879	550893	550894	550866	
	Splined Shaft		550901	550883	550891	550895	550904	
	Tandem Shaft		N/A	550903 Splined 552005 Keyed	550846 Splined 552006 Keyed	552007 Splined 550847 Keyed	552008 Splined 550905 Keyed	
9	Hanger	1	550885	550880	550884	550890	550864	
10	Trunnion	2	258943		258985	258909		
14	Guide ball	1	258098	258099	258100	258101	258102	
15	Guide Plate	1	450700	450696	450698	450699	450721	
16	Wear Plate	1	259025	258944	258986	258989	258912	
18	Spring (Barrel)	1	258166	258167	258168	2588169	258170	
19	Spring (Hanger)	1	258302	258303	258304	258305	258306	
20	Spring Seat (Hanger)	1	259019	259499	258983	258991	258917	
21	Plunger	1	259027	258938	258982	258988	258918	
22	Adjustment Screws	1	258959 Rear	258959 Rear	259411Rear	259411Rear	258919 Rear	
			258959 Side	258959 Side	259411 Side	259411 Side	258919 Side	
			N/A	258959 Tandem	258584 Tandem	258581 Tandem	259141 Tandem	
24	Gasket *	1	258426	258425	258424	258423	258422	
27	A-Washer (Barrel)	2	258108	258109	258110	258111	258112	
28	Pressure Compensator Kit (Standard)	1	261097 Buna-N 261098 Viton					
	Remote Pressure Compensator Kit (Code 7)		SAE 260199 Buna-N SAE 261100 Viton BSPP 261101 Buna-N BSPP 261102 Viton					
	Remote Load Sensing Compensator Kit (Code 19)		SAE 261103 Buna-N SAE 261104 Viton BSPP 261105 Buna-N BSPP 261106 Viton					
	Power Limiter Control Kit (UNF) (Code 26)		Rear Port	SAE 261107 Buna BSPP 261109 Buna	SAE 261111 Buna BSPP 261113 Buna	SAE 261115 Buna BSPP 261117 Buna	SAE 261119 Buna BSPP 261121 Buna	SAE 261127 Buna BSPP 261129 Buna
			Side/Tandem Port(s)	SAE 261108 Viton BSPP 261110 Viton	SAE 261112 Viton BSPP 261114 Viton	SAE 261116 Viton BSPP 261118 Viton	SAE 261120 Viton BSPP 261122 Viton	SAE 261128 Viton BSPP 261130 Viton
				SAE 262120 Buna BSPP 262122 Buna	SAE 261111 Buna BSPP 261113 Buna	SAE 261115 Buna BSPP 261117 Buna	SAE 261123 Buna BSPP 261125 Buna	SAE 261131 Buna BSPP 261133 Buna
SAE 262121 Viton BSPP 262123 Viton		SAE 261112 Viton BSPP 261114 Viton		SAE 261116 Viton BSPP 261118 Viton	SAE 261124 Viton BSPP 261126 Viton	SAE 261132 Viton BSPP 261134 Viton		
32	Compensator O-Ring	3	001512 Buna-N 101194 Viton					
38	Shaft Seal - Buna-N	1	258081		258082	258083		
	Shaft Seal - Viton		258299		258300	258301		
40	Retaining Ring (Barrel)	1	258157	258158	258159	258160	258178	
41	Retaining Ring (Bearing/Housing)	1	258330	258331	258332	258333		
43	Retaining Ring (Shaft Seal)	1	258327		258328	258329		
45	Nut, Hex.	1	199127		199134	199136		
46	Screw, Soc. Cap (Metric) (Rear Ports) *	4	199989	199911	199918	199717	199231	
	Screw, Soc. Cap (Metric) Side Ports & Tandem) *		198644	199985	199717		199234	
49	O-Ring	Codes 22 & 23	1		120689 Buna-N			
		Codes 21 & 31	2		141714 Viton			

PARTS LIST (continued)

	DESCRIPTION	QTY	HPV-6	HPV-10	HPV-15	HPV-20	HPV-29
50	O-Ring Code 22 Code 23	1	N/A	144929 Buna-N		144966 Viton	
				N/A		103999 Buna-N	259659 Viton
51	Coupling Code 21 Code 22 Code 23 Code 31	1	N/A	351354	351240	351394	351186
			N/A	351355	351101	351393	351185
				N/A		351392	351102
			N/A	351355	351101	351393	351185
52	Adaptor Code 21 Code 22 Code 23 Code 31	1	N/A	450634			
			N/A	450635			
				N/A		450672	
			N/A	450634			
53	Screw, Soc. Cap Code 22 Code 31	2	N/A	199682			
		6					
54	Threadseal	1	258412 Buna-N 258434 Viton		258416 Buna-N 258419 Viton		258415 Buna-N 258437 Viton
56	Dowel Pin (Barrel)	3	258103	258104	258105	258106	258107
58	Plug, Case Drain SAE Plug, Case Drain BSPP	1	251248 Buna-N 259831 Viton	259414 Buna-N 259415 Viton		259138 Buna-N 258264 Viton	
				258525 Buna-N 260662 Viton		258526 Buna-N 260309 Viton	
61	Escutcheon Blank	1	261163S				
62	Screw	2	250597				
64	Guide Sleeve *	1	259026	258940	258984	258990	258920
65	Needle Bearing *	1	258127	258128	258129	258130	258131
66	Pin (Cover) *	1	258336	258337	258338		258339
67	Expander Plug *	1	259176				
68	Retaining Ring (Shaft/Bearing)	2	258290		258291	258292	
69	Ball Bearing	1	258191	258192	258193	258194	
70	Key	1	126225	101580	001396	259001	
71	Screw, Soc. Cap	4	199233 Standard 199086 Codes 7, 19, 26				
83	Threaded Rod	2	N/A	259691			
84	Nut, Hex. Jam	2	N/A	199127			

* Included in Cover Kit.

KIT LIST

DESCRIPTION	HPV-6	HPV-10	HPV-15	HPV-20	HPV-29
Seal Kit - Buna-N	258076	258077	258078	258079	258080
Seal Kit - Viton	258294	258295	258296	258297	258298
Rotating Group Kit (CW Rotation)	258132	258133	258134	258135	258136
Rotating Group Kit (CCW Rotation)	258181	258182	258183	258184	258185
Keyed Shaft Kit	258122	258123	258124	258125	258126
Splined Shaft Kit	258259	258261	258262	258278	258279
Tandem Shaft Kit (Keyed)	N/A	259938	259939	259940	259941
Tandem Shaft Kit (Splined)	N/A	259934	259935	259936	259937

PARTS LIST (continued)

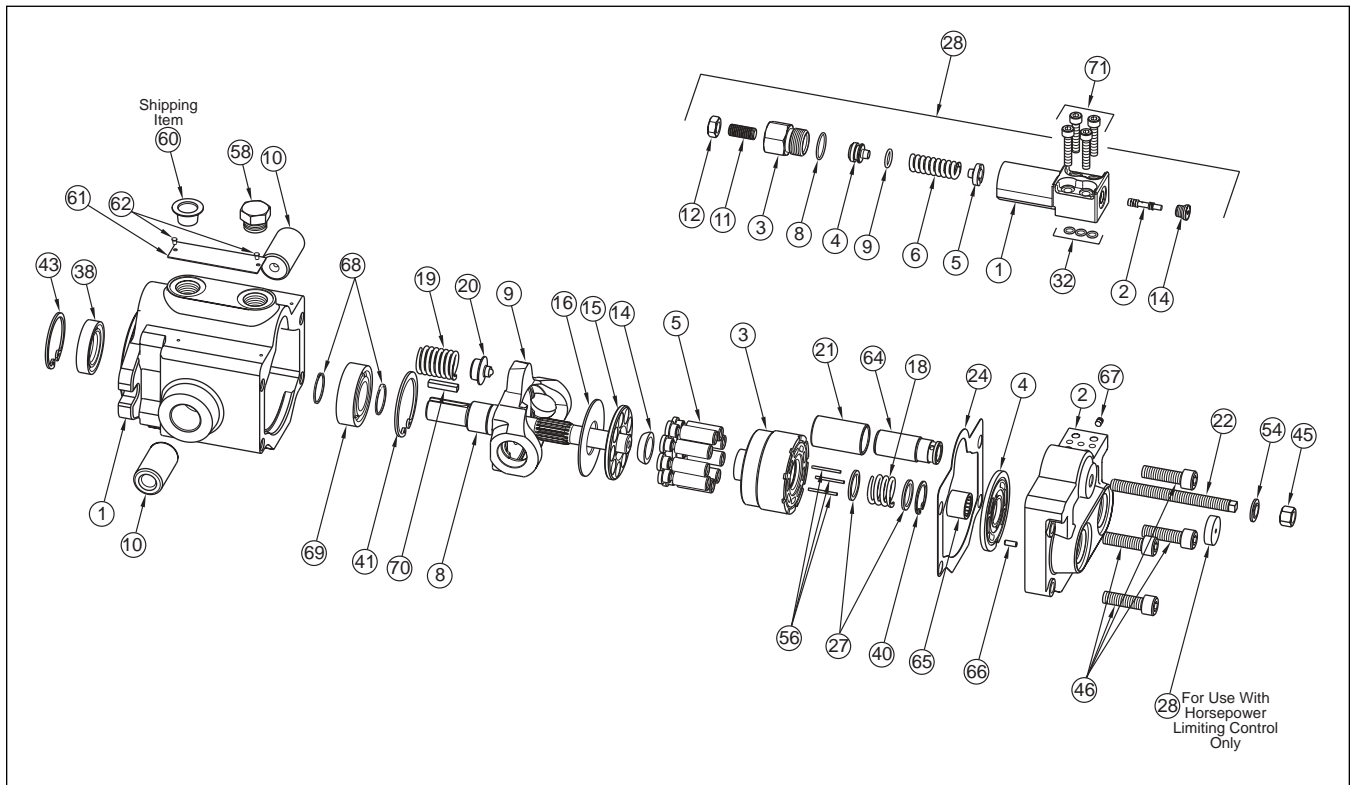

Figure 14, HPV Pump and Standard Pressure Compensator, Parts Identification

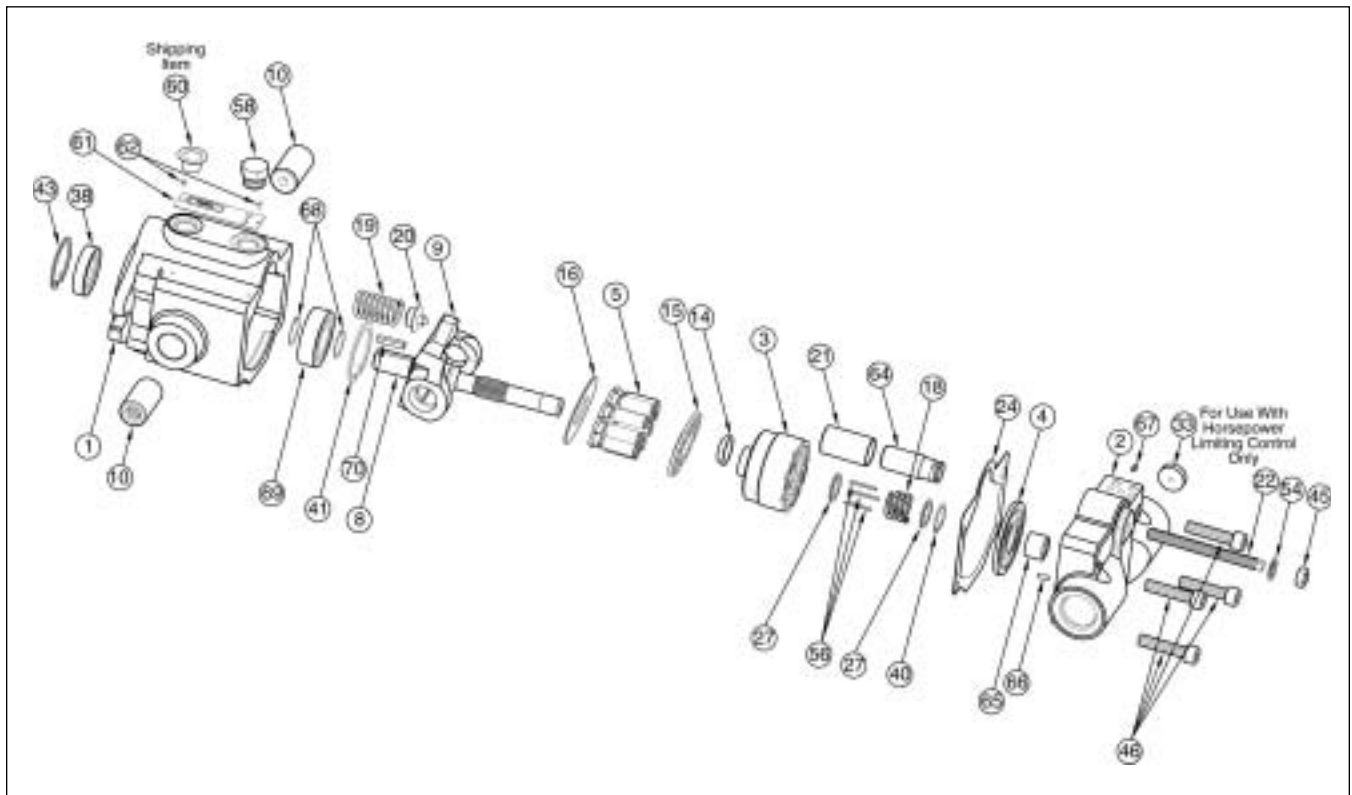

Figure 15, HPV Side Port, Parts Identification

PARTS LIST (continued)

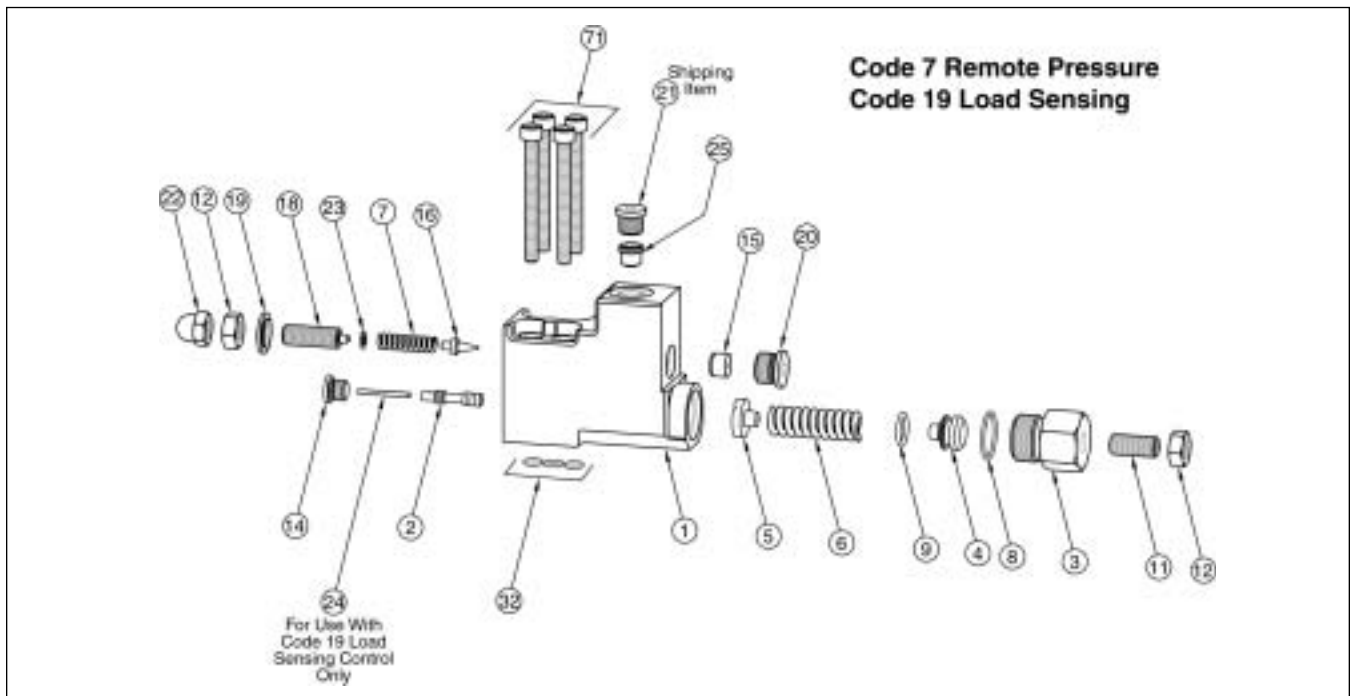

Figure 16, Code 7 and Code 19 Pressure Compensator, Parts Identification

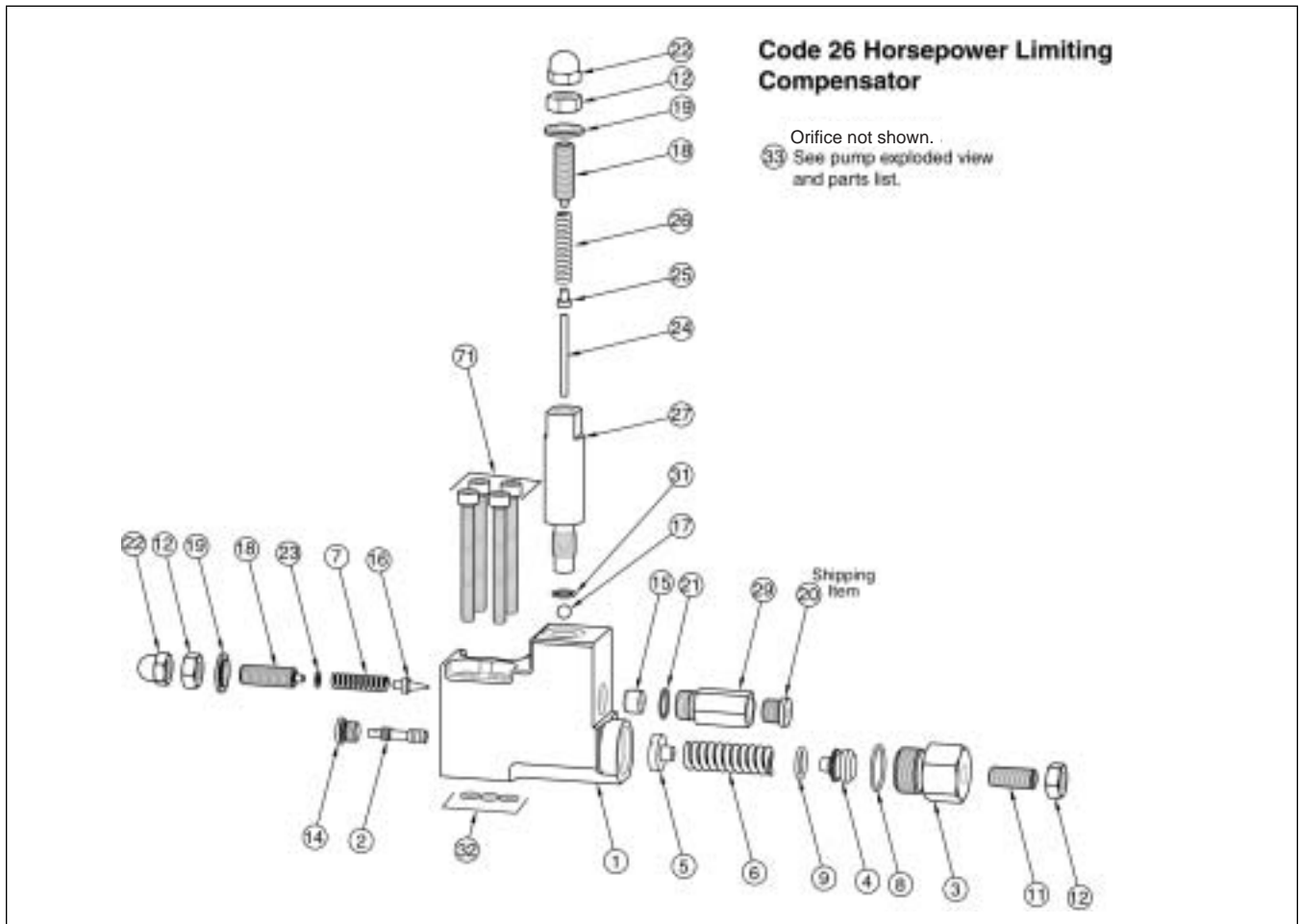

Figure 17, Code 26 Horse Power Limiting Pressure Compensator, Parts Identification



Continental Hydraulics
12520 Quentin Avenue South
Savage, MN 55378 U.S.A.
Phone: (952) 895-6400 Fax: (952) 895-6444
www.continentalhydraulics.com

Because Continental Hydraulics is continually improving its products, specifications and appearance are subject to change without notice.

