

EH series

HITACHI

Reliable solutions

EH1100



DUMP TRUCK

Model Code : EH1100-s

Nominal Payload with Standard Equipment : 63.5 tonnes (70.0 tons)

Target Gross Machine Operating Weight : 108 950 kg

Engine Rated Power : 567 kW (760 HP)

Hitachi Cutting Edge Technology Brings Best Performance and Comfort.

Hitachi Technology

Hitachi Trucks, like Hitachi Excavators are designed and manufactured using cutting edge technology. Hitachi truck monitoring and control is performed by Hitachi electronic components and software, resulting in excellent machine reliability and operator comfort.

High-Powered Engine Selection

Strong, reliable power is provided in by a choice of diesel powered engines. The EPA Tier 2 emission certified engines maintain a low fuel consumption level.

Long Frame Life

Frame rails are tapered from front to rear to distribute the load evenly over the entire length of the chassis. In place of castings, hot rolled steel is used as it is known to be more homogeneous and easier to repair. Weld joints are oriented longitudinally to the principal flow of stress for strength and long life. Proven design and manufacturing methods with state-of-the-art ultrasonic testing ensure a quality product.

Unique Body Design

The single sloped floor evenly distributes material shedding during dumping. Horizontal floor and side rail stiffeners distribute load shocks evenly over the entire body length, minimizing stress concentrations in any one area. Closely spaced floor stiffeners reduce wear due to impact loading.



Well Matched: EH1100-s & Excavators

Excavator	ZX870LCH-s (BH)		EX1200-s (BH)		EX1200-s (LD)
Boom	7.1 m - BE Boom	8.4 m - H Boom	9.0 m - Boom	7.55 m - BE Boom	—
Arm	2.95 m - BE Arm	3.7 m - H Arm	3.6 m - Arm	3.4 m - BE Arm	—
Bucket Capacity	*4.3 m ³	*3.5 m ³	*5.2 m ³	*6.7 m ³	6.5 m ³
Passes	8 or 9	10 or 11	7	5 or 6	5 or 6

BH : Backhoe LD : Loading shovel *SAE, PCSA heaped capacity

Rugged Construction

Technologically Advanced

The EH1100-s is designed to develop low cycle times and extra efficiency in the heavy duty applications of quarrying and mining. This truck provides low operating costs, unparalleled productivity and overall quality through its superior structure and systems design.

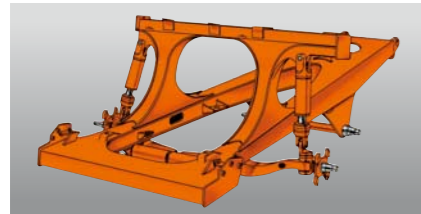

Robust Frame

Full fabricated box section main rails with section height tapered from front to rear. Narrow at the rear to support the load and wider at the front allowing truck stability and excellent engine access for servicing. One piece top and bottom flanges that eliminate cross member tie in joints and provide a large exposed center area for access to major components. Large radii at frame junctions are blended and ground to minimize stress concentrations. Weld joints are oriented longitudinally to the principal flow of stress for greater durability and more strength. Frame utilizes 345 MPa yield high strength low alloy steel that is robotically welded to ensure consistently high quality welds.

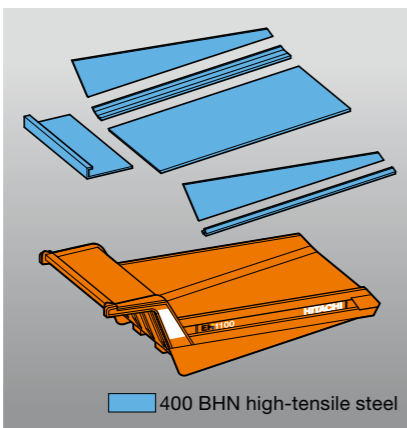

Reinforced Body

Built for quarry and mining applications, the EH1100-s body uses an 18 mm floor plate and 8 mm side plates made of 400 BHN high-tensile steel. This provides high resistance to wear and impact. A low loading height and large target area allow easy, quick loading by a variety of loading tools.

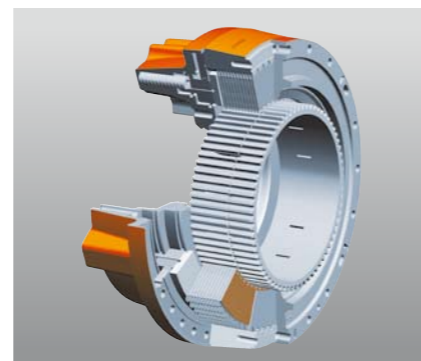

Hydraulic Brake

The rear wet disc brake assemblies have been upgraded to include spring applied pistons that function to provide a strong, reliable and low maintenance integral parking brake. The Hitachi hydraulic braking system is durable and provides maximum available braking under tough ground conditions for best control.



Ease of Operation



Hi-Tech ROPS / FOPS Cab

The new Hi-TECH (Hitachi Technology) ROPS/FOPS cab features a 265 mm (10.4") LCD screen positioned to the right of the steering wheel to provide better visibility of the road ahead. The cab uses double-wall construction and a 3-point rubber isolation-mount to absorb shocks and noise. The high powered heater and air conditioning unit provides operator comfort in all environments and working conditions. The central controller, built by Hitachi and also used in excavators, will perform its function of processing input and output information with reliability during the most rigorous haul cycle.



Auto-Lubrication System

A ground level accessible grease pump assembly automatically feeds lubricant to grease points throughout the truck via plumbing. The lubricant is delivered in time controlled and metered quantities to all connected lube points in the system. Hitachi equips the EH1100-s with a Lincoln Auto-Lubrication system. Control, timing and monitoring of the Lincoln system is a function of the Hitachi central controller.



Auto Lubricator

Superior Suspension

The Hitachi ACCU-TRAC suspension system delivers excellent maneuverability, even at higher speeds. The trailing arm layout offers greater ease of servicing while improving truck performance compared to suspended king-pin designs. The pivot mounting of the trailing arm design allows only axial input to the strut and allows wheel movement in the vertical plane only.

Features:

- Lateral forces that act on the front wheels are minimized, resulting in reduced tire scuffing.
- Dynamic friction (side-wall force) within the strut is low due to the features of the ACCU-TRAC design, allowing the use of a lighter strut engineered to a smaller diameter and longer stroke.
- The necessary frame bulk (horse-collar structure) needed to mount a suspended king-pin is non-existent.
- The elimination of the "horse-collar" member provides greater engine access.
- The NEOCON strut used with the ACCU-TRAC suspension, improves operator and component isolation, provides better hauler stability and predictable operational control.
- Locating the king-pin close to the wheel assembly and at a slight angle results in low "Dry Park Steering" effort.
- Development of the compressible media, NEOCON-E™ fluid (silicon based, non-petroleum) for use in the suspension strut with Helium gas, results in an improved energy absorption (isolation) system and an improved energy release (stability) system that responds favorably whether traveling empty or with payload in a wide range of ambient temperatures.

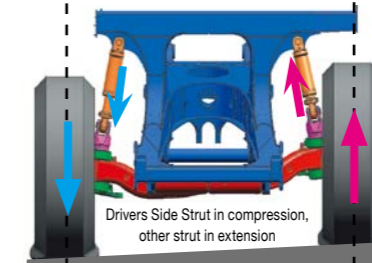
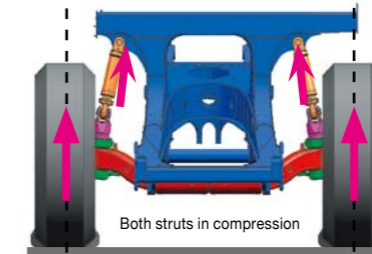
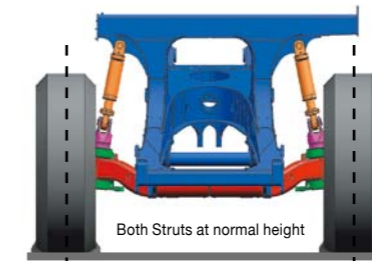

With no horizontal deflection



The ACCU-TRAC suspension design allows the front struts to be removed and installed without removing the trailing arms, brakes or tires. This relates to fewer tools and less labour required to perform the repair, which aims to reduce the amount of hauler downtime, increasing productivity.

Spindle

Each spindle is controlled by a hydraulic steering cylinder, rotates around the king-pin and the outer end of the trailing arm to position the wheels for steering. The spindles are attached by one tie-rod.

King-Pin

Retains the spindle to the trailing arm. Spindle rotates around the king-pin, which is locked in position. The Neocon-E strut attaches to the top.

Trailing Arm

Main suspension member to which other suspension components are attached. The trailing arms hinge on a torque tube that is clamped to the front of the frame.

Neocon Strut

The energy absorption and release component of the ACCU-TRAC suspension system. Pinned to ball bushings at the frame and at the top of the king-pin to prevent bending moments from transferring to the strut. Receives only axial input.

Trailing Arm Suspension (Front)

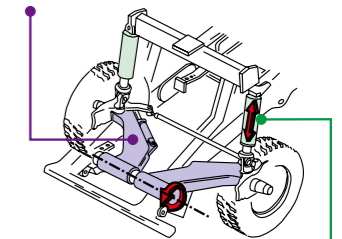

NEOCON Strut (Front/Rear)

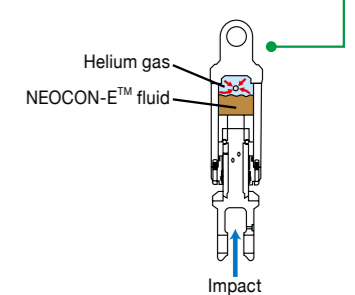

SPECIFICATIONS

ENGINE

Model.....	Cummins QSK23
Type.....	4 Cycle Inline 6, diesel injection
Emission Certification ..	U.S. E.P.A Tier 2
Aspiration.....	Turbocharged / Aftercooled
Rated Power	
SAE J1995, gross ..	567 kW (760 HP) at 2 100 min ⁻¹ (rpm)
SAE J1349, net.....	520 kW (698 HP) at 2 100 min ⁻¹ (rpm)
ISO 9249, net.....	520 kW (698 HP) at 2 100 min ⁻¹ (rpm)
EEC 80/1269, net ..	520 kW (698 HP) at 2 100 min ⁻¹ (rpm)
Maximum Torque.....	3 091 N·m (315 kgf·m) at 1 300 min ⁻¹ (rpm)
Piston Displacement...	23.0 L
Bore and Stroke.....	170 x 170 mm
Torque Rise.....	20 %
Starting	Electric

Model.....	MTU Detroit Diesel 12V Series 2000
Type.....	4 Cycle, V12, diesel injection
Emission Certification ..	U.S. E.P.A Tier 2, E.U. Stage II*
Aspiration.....	Turbocharged / Aftercooled
Rated Power	
SAE J1995, gross ..	567 kW (760 HP) at 2 100 min ⁻¹ (rpm)
SAE J1349, net.....	520 kW (698 HP) at 2 100 min ⁻¹ (rpm)
ISO 9249, net.....	520 kW (698 HP) at 2 100 min ⁻¹ (rpm)
EEC 80/1269, net ..	520 kW (698 HP) at 2 100 min ⁻¹ (rpm)
Maximum Torque.....	3 091 N·m (315 kgf·m) at 1 350 min ⁻¹ (rpm)
Piston Displacement...	23.9 L
Bore and Stroke.....	130 x 150 mm
Torque Rise.....	20 %
Starting	Electric

*Fuel optimized version is available.

TRANSMISSION

The transmission employs Shift Energy Management (SEM) which reduces engine torque during transmission shifts resulting in longer drivetrain life and increased operator comfort.

Additionally an Optimum Start Range feature has been engineered for the EH1100-s. This feature provides reduced fuel use, less noise and more operator comfort during unloaded truck operation. When the automatic onboard payload weighing system identifies an unloaded body, the transmission is activated to start the upshifting sequence from 3rd gear.

Model.....	Allison H6620A
Design.....	Fully automatic, planetary type with integral lock-up converter
Mounting/Position	Remote from engine and rear axle for serviceability
Ranges	6 forward, 2 reverse
Control.....	Allison CEC3 electronics shift system with SEM (Shift Energy Management) and OSR (Optimum Start Range)

Gear	Ratio	km/h	Gear	Ratio	km/h
1	4.00	9.7	5	1.00	39.0
2	2.68	14.5	6	0.67	58.2
3	2.01	19.4	R1	5.12	7.6
4	1.35	28.9	R2	3.46	11.3

DRIVE AXLE

Model Differential.....	2354
Axle Design	Full floating axle shafts using a model 2354 differential and single reduction planetaries at each wheel
Traction Control	An optional electronic feature that includes the Electronic Downhill Speed Control feature
Differential and Final Drive Ratios	
Ratios	
Differential	3.64 : 1
Planetary	5.80 : 1
Total Reduction	21.11 : 1
Maximum Speeds	
with 24.00R35 tires	58.2 km/h

TIRES

Front	24.00 R35(**) E4 (Radial) [Standard]
Rear.....	24.00 R35(**) E4 (Radial) [Standard]
Rim Width	432 mm (17 in)
Alternative tires and tread patterns may be available.	

Note:

Certain job conditions may require higher rated TKPH (TMPH) tires in order to maintain maximum production. Hitachi recommends evaluating the job conditions and consulting the tire manufacturer to make proper tire selection.

ELECTRICAL SYSTEM

24 volt starting, lighting and accessories system. 75 ampere alternator with integral transistorized voltage regulator. Two 12 V heavy duty batteries capable of 1425 cold cranking amps, each, at -18 degree C (0 degree F). A Hitachi solid state reprogrammable controller controls and monitors hauler systems, provides output information to control gauges and lights and incorporates connections for diagnostic tools.

BODY CAPACITY

	m³
Struck (SAE)	32.7
Heap 3 : 1	38.2
Heap 2 : 1 (SAE)	41.5

Body capacity and payload subject to change based on customer specific material density, options and application.

WEIGHTS (Approximate)

Net machine weight stated below includes standard equipment.

Net machine weight changes will directly affect the Nominal Payload.

Chassis with Hoist	34 260 kg
Body	11 190 kg
Net Machine Weight	45 450 kg
The Net Machine Weight specification includes operator and 100 % fuel.	
Nominal Payload	63.5 tonnes
Target GMOW	108 950 kg

The Nominal Payload specification is calculated using the Hitachi Loading Policy. Specific job site requirements may result in an adjustment to the Nominal Payload weight.

Consult your Hitachi dealer for a truck configuration which will match your haulage application.

Major Options

The following list of options are examples which will change the Nominal Payload.

- Automatic Fire Suppression
- Body Liner, heavy duty and partial
- Deck Mounted Muffler

Weight Distribution	Front	Rear
Empty	50 %	50 %
Loaded	34 %	66 %

STEERING SYSTEM

Closed-center, full-time hydrostatic steering system using two double-acting cylinders, pressure limit with unload piston pump and brake actuation/steering system reservoir. An accumulator provides supplementary steering in accordance with ISO 5010 (SAE J1511). The Operators steering wheel offers 35 degrees of tilt and 47.7 mm of telescopic travel.

Steering Angle	39 degrees
Turning Diameter: (SAE)	19.85 m
Steering Pump Output (at 2 100 min ⁻¹ (rpm))	94.7 L/min
System Pressure	19.0 MPa

HYDRAULIC SYSTEM

Two 2-stage, double-acting cylinders, with cushioning in retraction, inverted and outboard mounted. Separate Hoist/Brake Cooling reservoir and independent tandem gear pump. Control valve mounted on reservoir.

Body Raise Travel	59 degrees
Body Raise Time (at 2100 min ⁻¹ (rpm))	11.4 seconds
Body Down Time (at idle)	14.2 seconds
Brake Cooling Pump Output (at 2100 min ⁻¹ (rpm))	176 L/min
Hoist Pump Output (at 2100 min ⁻¹ (rpm))	468 L/min
System Relief Pressure (Hoist)	17.2 MPa

BRAKE SYSTEM

Brake system complies with ISO 3450 (SAE J1473).

All-hydraulic actuated braking system providing precise braking control and quick system response. The Hitachi brake controller has a unique variable front to rear brake proportioning that maximizes the stopping performance under all road conditions.

Service

All-hydraulic actuated front dry disc brakes and rear oil-cooled wet disc brakes are equipped.

Wet Disc Brake

The Hitachi wet disc brake is engineered for long service life even in the most extreme environments. The wet disc brakes are located on the rear axle and provide service braking, secondary braking, retarding and parking. The brakes are a multi-plate design, and continuously oil-cooled. The sealed design protects against environmental contamination for prolonged service life. The wet disc brake is designed with automatic retraction to prevent drag and with spring activation for parking. Separate pedals activate the service braking and retarding functions.

Front Axle - Dry Disc

Disc diameter each (2 discs/axle)	686 mm
Brake surface area per axle	7 316 cm ²
Lining area per axle	2 787 cm ²
Brake pressure (Max.)	15.9 MPa

Rear Axle - Oil-Cooled Wet Disc

Brake surface area per axle	64 605 cm ²
Brake pressure (Max.)	4.8 MPa

Secondary

Two independent circuits within the service brake system provide back-up stopping capability. Manual application of this system will stop the machine within prescribed braking distance. Automatic application will result if supply pressure is low and the operator has failed to react to indicators and alarms.

Wet Disc Parking Brake

The parking brake is internal to the rear wet disc brakes.

Retarder

Foot-operated valve controls all-hydraulic actuation of oil-cooled wet disc brakes on rear axle. System provides modulated pressure to rear brakes for constant speed control.

Continuous	656 kW	(880 HP)
Intermittent	1 270 kW	(1 700 HP)

Load/Dump Brake Apply

Through activation of a switch by the operator, a solenoid is energized, sending full brake pressure to apply the rear Wet Disc brakes. For use during the load and dump cycles.

SPECIFICATIONS

HI-TECH ROPS / FOPS CAB

Hi-Tech ROPS / FOPS Cab

The EH1100-s ROPS system complies to ISO 3471: 2008 for the rigid dump truck and tractor configurations. The cab also complies with FOPS ISO 3449: 2005. Multilayered floor mats and wall panels act to absorb sound and control interior temperature.

A properly maintained cab from Hitachi, tested with doors and windows closed per work cycle procedures in ISO 6394: 2008 (dBA), results in an operator sound exposure Leq (Equivalent Sound Level) of 75 dB(A).

A three-point rubber iso-mount arrangement to the deck surface minimizes vibration to the operator compartment.

Excellent Serviceability

A removable front panel allows easy access to service brake valves, retarder valve and heater assembly. A removable cover located behind the operators' seat provides easy access to electrical and electronic system components.

Comfort and Ease of Operation

A 265 mm (10.4") LCD screen is positioned slightly to the right of steering wheel to provide better visibility through the front cab window and to prevent the steering wheel spokes from causing visual obstruction. The LCD is pleasant to view in all lighting conditions and incorporates large interactive buttons to toggle to various monitor selections within close reach of the operator. Conventional gauges and lights are replaced by computer generated graphics that perform the same purpose of providing truck system performance information with trouble conditions supported by messages in text as secondary. The pass-through cab offers a spacious environment. The interior design allows the operator to exit through the left or right side doorway, making either one of the access stairways easily available to the operator. Multiple position adjustable seat, tilt/telescopic steering wheel, filtered cab ventilation and high ground visibility all contribute to convenience, control and comfort.

SUSPENSION

Front and Rear Suspension

For years, Hitachi haulers have enjoyed an industry-wide reputation for superior suspension systems. That experience and knowledge has now been pushed to the next level, to develop the truly advanced ACCU-TRAC suspension for the EH1100-s. To make sure it was fine tuned to the limit, Lotus Engineering, a world leader in suspension design, was contracted to review the entire system to assure optimized ride and handling performance.

The ACCU-TRAC suspension system features independent trailing arms for each front wheel with NEOCON struts, containing energy absorbing gas and compressible NEOCON-E™ fluid, mounted between the king pins and the frame. This arrangement allows a wider front track that provides a better ride, improved stability and a reduced turning circle. The rear axle housing has an A-frame mounting. The rear NEOCON struts are mounted in a more vertical position which allows a more pure axial loading and reduces the tractive and braking forces transmitted to the nose cone.

NEOCON struts outperform competitive strut designs by improving isolation, stability, and control. Improved isolation means reduced impact loading on the structural members of the machine and greater operator comfort, resulting in longer equipment life and increased productivity. Improved stability means more consistent dynamic response of the machine to fluctuating load energy, resulting in predictable machine performance. Improved control means better machine maneuverability.

The Hitachi frame and ACCU-TRAC suspension system are designed to work in unison to provide maximum structural integrity and operator comfort. The fabricated rectangular frame rail construction provides superior

resistance to bending and torsional loads while eliminating unnecessary weight. The unique ACCU-TRAC independent trailing arm suspension absorbs haul road input, minimizing suspension-induced frame twisting while providing independent tire action.

NEOCON ride struts are mounted with spherical bushings, eliminating extreme sidewall forces by ensuring a purely axial input to the ride strut. The wide track stance of the ACCU-TRAC suspension system and the long wheel base assure a more stable, comfortable ride.

BODY

The body has been made to the single slope, flat floor design.

The rear hinge has been designed to allow the hinge pin to float when the body is in the fully lowered position.

The weight of the body and payload is distributed across rubber body pads that are evenly spread across the length of the body rail-box that rests on the truck frame.

Plate Thickness (Standard Body):

	mm	(in)
Floor	18	(0.69)
Front	10	(0.38)
Sides	8	(0.31)
Canopy	6	(0.25)
Valley	8	(0.31)

Options for Standard Body:

Body Liners (Medium Duty)		
Floor & Valley	10	(0.38)
Sides & Front	6	(0.25)
End Protection	10	(0.38)
Body Liners (Heavy Duty)		
Floor & Valley	13	(0.50)
Sides & Front	8	(0.31)
End Protection	10	(0.38)
Partial Liner (Heavy Duty)		
Floor & Valley	13	(0.50)
End Protection	10	(0.38)
Rock Cap		
Top of the Body Side Plate	10	(0.38)

Plate Thickness (Optional Quarry Body):

Floor	25	(1.00)
Front	16	(0.63)
Sides	14	(0.55)
Canopy	8	(0.31)
Valley	16	(0.63)

The horizontal stiffener design of the Hitachi body minimizes stress concentrations in any one area. Load shocks are dissipated over the entire body length.

The closely spaced floor stiffeners provide additional protection by minimizing distance between unsupported areas.



HITACHI LOADING POLICY

Operational Benefits

Haulroad Safety

Truck loading within the limitations of the Hitachi Loading Policy will result in designed and certified operational performance of the steering, brake and ROPS systems of the truck.*

Efficient Productivity

Truck loading within the limitations of the Hitachi Loading Policy will result in optimizing the fuel economy and travel speed performance to which the truck was designed to.*

Availability and Maintenance

Lower maintenance costs and higher availability can be achieved if truck loading is within the limitations of the Hitachi Loading Policy.*

*Hitachi recommended maintenance is required.

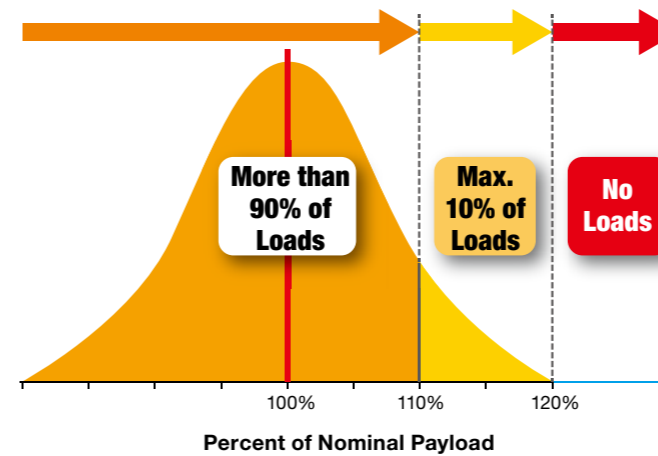

- 1: More than 90% of all loads must fall below 110% area (Orange area).
- 2: If necessary due to excessive variation in material density, loader bucket fill-factors or bucket sizes, loading the truck to between 110% and 120% of Nominal Payload is allowed if it accounts for less than 10% of all loads (Yellow area).
- 3: Loading above 120% of Nominal Payload is not allowed. (Red Area)

SERVICE CAPACITIES

	L
Crankcase (includes filters) for MTU	83.3
Crankcase (includes filters) for Cummins	70.0
Cooling System for MTU	335
Cooling System for Cummins	147
Transmission, Cooler and Lines	93.3
Fuel Tank	700
Hydraulics	
Hoist Tank and System	265
Steering Tank and System	112
Drive Axle (2 wheels and differential)	103
Windshield Washer Fluid	5.7

STANDARD EQUIPMENT

GENERAL

Access system, step ladder drivers side and service side	Ground level auxiliary start (boost) receptacle
ACCU-TRAC suspension system	Ground level engine shutdown
All-hydraulic braking	Guard rails
Allison H6620A transmission	Hoist interlock
Battery disconnect switch, ground level	Hoist tank sight gauge
Body down cushioning	ISO decals
Body down indicator	Load/dump brake
Body up, reverse inhibit	Lube system, Lincoln automatic
Body up speed restriction	Mirrors, left and right, hand adjustable
Canopy spill guard	Mud flaps
Continuous heated body	NEOCON-E suspension struts
Cooling system sight gauge	Park brake interlock
Cooling system surge tank	Payload weighing system, automatic
DC -DC , 24 to 12V converter	Radiator grille guard
Driveline guard, front	Rear view camera system
Electric horns	Reverse alarm and light
Electric start	Rock ejector bars
Electronic hoist	Steering accumulator
Engine belt protection	Steering tank sight gauge
Engine idle timer	Tires 24.00 R35
Fan guard	Tow points, front
Fenders	Transmission oil level sensor
5 piece rims	Transmission oil level sight gauge
Fluid drain valves	Two speed reverse
Fluid sampling ports	Water separator included in fuel filter
Fixed steering stops	
Front brake cut-off switch	
Front corner mirrors	
Fuel tank level gauge	

CAB

Access, left and right side doors	ISO driver envelope
Air conditioning	LCD operator information screen, 265 mm (10.4")
Air filtration/replaceable element	Mechanical RHS and LHS windows
Air suspension seat *	Parking brake test feature, automatic
Cab interior light	Quick connect hydraulic test ports
Camera monitor, within operators LCD	Rubber floor mat
Comfort shift, Optimum Start	Safety glass
Range, when empty	Seat belts, retractable (operator and trainer)
Cup holders x 4	Speakers, antenna and wiring only
Data logging unit (DLU)	Sunvisor, pull-down
Door locks	Tilt/telescoping steering wheel
Foot rest, left	Tinted glass, all windows
Fuses	Trainers seat
GPS communication	12V power port
Heater and defroster	12 volt accessory connection
Hill Hold	Windshield washer
Integral ROPS/FOPS cab	Windshield wiper, intermittent
Integrated engine diagnostics connector	
Integrated transmission diagnostics connector	
* Features	
Parking brake alarm: Audible when parking brake not applied and operator is not seated	
Seat belt alarm: Audible and visible when truck is running and seat belt is not buckled	
3 point seat belt : Standard	

ELECTRONIC DISPLAY (Hitachi Monitoring Information)

Lights with ISO symbols	LCD Screen Information
Active Traction Control with Speed Limiter	Brake oil pressure
Battery charge	Brake oil temperature
Body up	Date and time
Brake system oil pressure	Engine coolant temperature
Central warning (stop)	Engine oil pressure
Central warning (yellow caution)	Filter restrictions
Electronic downhill speed control (optional)	Fuel gauge
Engine coolant level	Haultronics III payload information
Engine oil pressure	Hourmeter
Filter restrictions	Load Count
High beam	Odometer
Parking brake	Parking brake applied
Payload meter and number	Selectable units of measure
Retarder temperature	Speedometer
Seat belt disconnected	Steering oil pressure
Steering oil pressure	Steering oil temperature
Transmission oil temperature	System diagnostics
Turn signal/ hazard	Tachometer
	Transmission oil temperature
	Transmission range attained
	Transmission range selection
	Trip Odometer
	Voltmeter

MACHINE LIGHTS

LED amber turn signals and four-way flashers	LED head lights (4)
LED back-up light	LED brake/retarder lights (2)

OPTIONAL EQUIPMENT

CAB

Air suspension seat, semi-active, w/ heat, w/ lumbar*	Circuit Breakers in place of fuses
AM-FM radio w/ CD & Aux. input	Electric RHS and LHS power windows
	Orbcomm communication
* Features	
Parking brake alarm: Audible when parking brake not applied and operator is not seated	
Seat belt alarm: Audible and visible when truck is running and seat belt is not buckled	
3 point seat belt : Standard	

CHASSIS

Body liners (400BHN) plates, medium, heavy duty or partial	Rear driveline guard
Canopy spill guard extension	Rock cap
Cold weather package	Service center with fast fuel
Mild cold weather package (0 deg C to -20 deg C) (32 deg F to -4 deg F)	Service center without fast fuel
Extreme cold weather package (-20 deg C to -35 deg C) (-4 deg F to -31 deg F)	Service lighting, engine, transmission, service deck (4)
Custom bodies available	Side extensions
Electrically heated mirrors	Side Mudguards, mounted to cab deck
Engine access step	Side view camera (RHS)
Engine side panels, for dust / dirt protection	Spare rim
GPS communication, e-Service	Steering accumulator, region Canada
LHS arm guard	Tires (type & rating)
Lube system, Groeneveld	TranSynd™ transmission fluid
Muffler, frame mounted, exhaust flow to rear of chassis	Variable pitch fan (Cummins)
	Wheel chocks
	Work lights, forward facing -LED
	Work lights, rear facing -LED

MISCELLANEOUS

Extra operators manual	Service Manual - CD
Extra parts manual - CD	Service Manual - hardcopy
Extra parts manual - hardcopy	

OPTIONAL EQUIPMENT WEIGHT

	kg
LHS arm guard	56
Body liners (400BHN) plates, medium	2 850
Body liners (400BHN) plates, heavy duty	3 680
Body liners (400BHN) plates, partial	2 430
Lube system, Groeneveld	100
Rock Cap	269
Side Extensions	485
Canopy spill guard extension	99

Standard and optional equipment may vary from country to country. Special options provided on request. All specifications are subject to change without notice.

DIMENSIONS

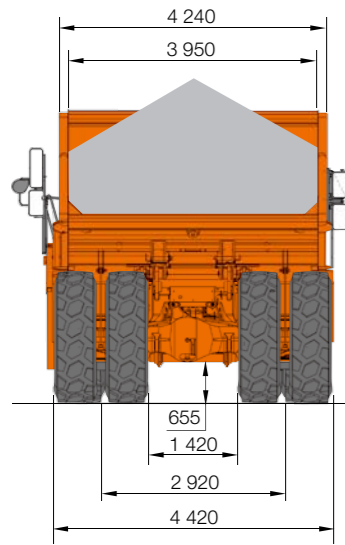

unit : mm

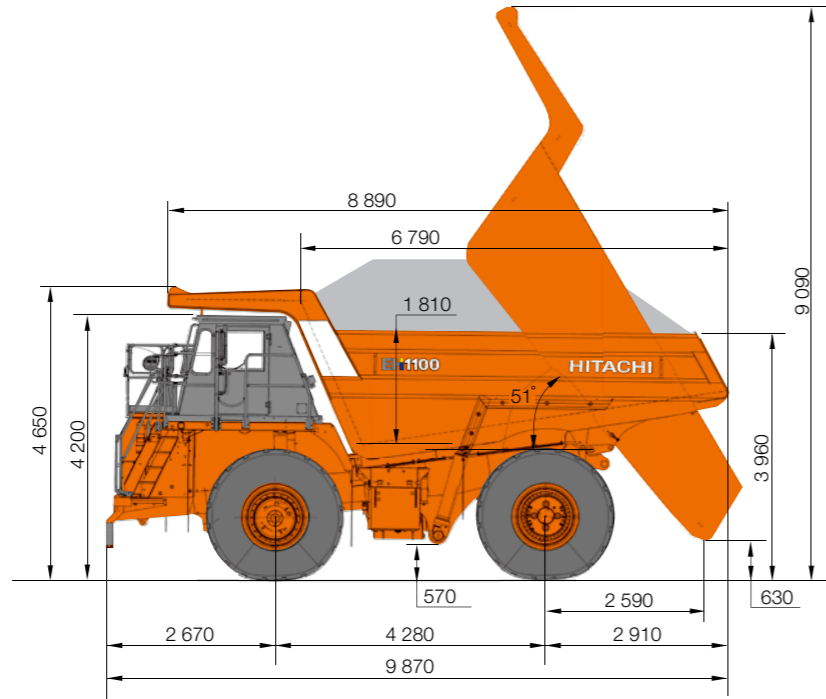
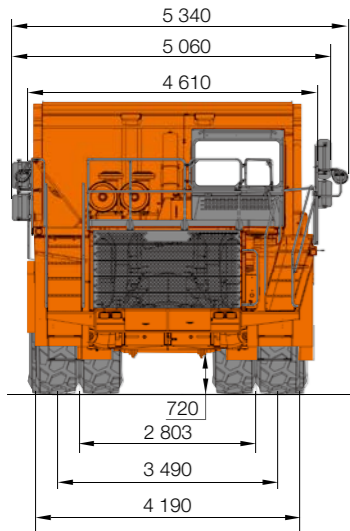

Note: Dimensions shown are for empty machine with standard body and 24.00R35(**)E4 tires.
Exact dimensions may vary due to tire make, type, and inflation pressure.

PERFORMANCE DATA

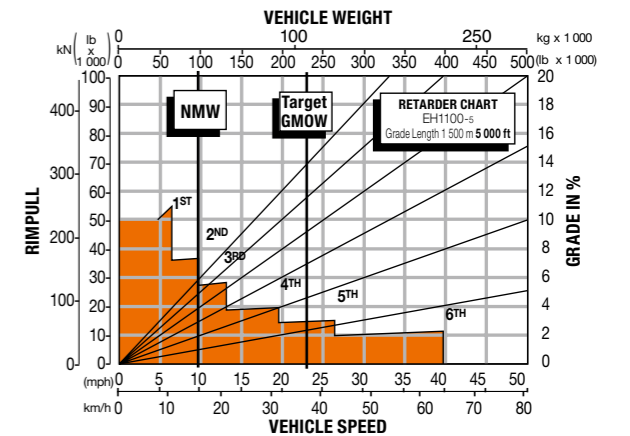
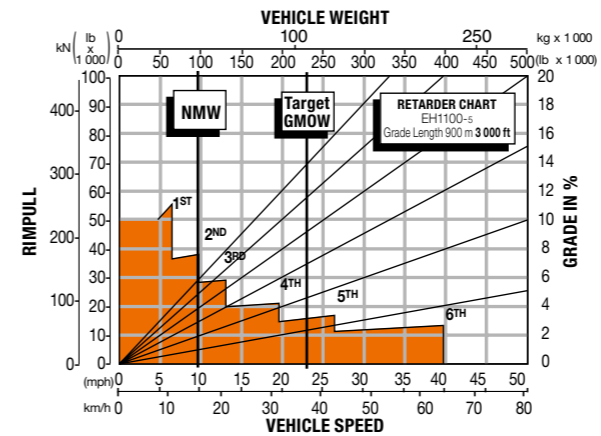
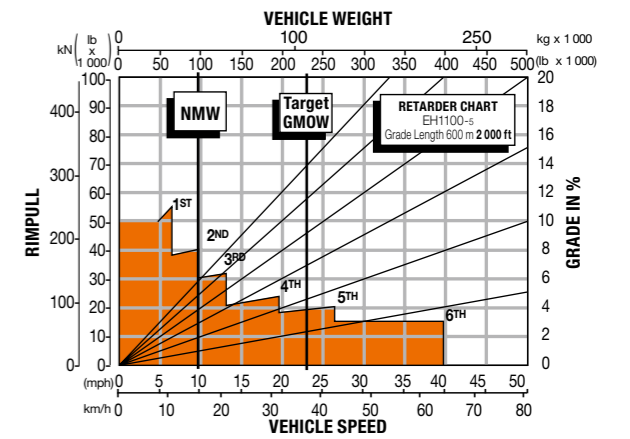
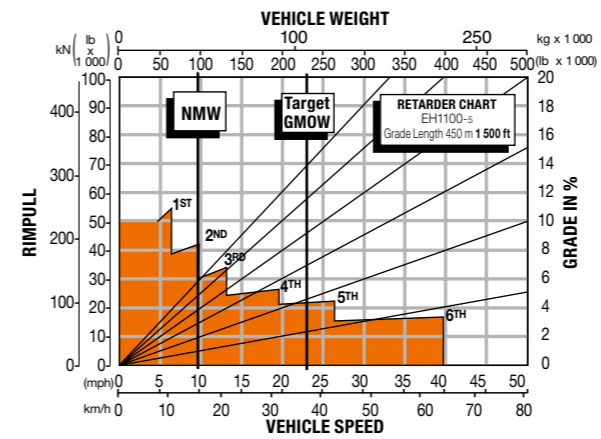
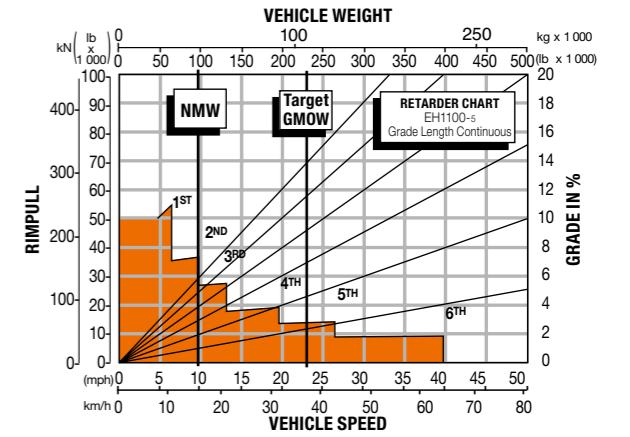
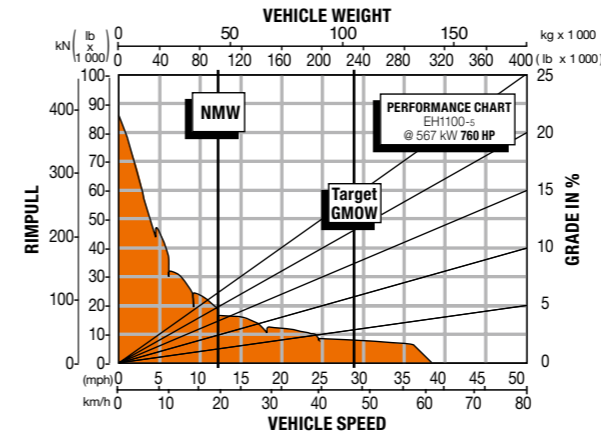

NOTES:

Diagonal lines represent total resistance (Grade % plus rolling resistance %).

Charts based on 0 % rolling resistance, standard power of engine, standard tires and gearing unless otherwise stated.

1. Find the total resistance on diagonal lines on right-hand border of rimpull or retarder chart.
2. Follow the diagonal line downward and intersect the NMW or GMOW weight line.
3. From intersection, read horizontally right or left to intersect the rimpull or retarder curve.
4. Read down for machine speed.



Before using a machine with a satellite communication system, please make sure that the satellite communication system complies with local regulations, safety standards and legal requirements. If not so, please make modifications accordingly.

These specifications are subject to change without notice.
Illustrations and photos show the standard models, and may or may not include optional equipment, accessories, and all standard equipment with some differences in color and features.
Before use, read and understand the Operator's Manual for proper operation.