



Yes, you can.®



## *Invacare® Storm<sup>3</sup> Competition / FFH*

---

*Power wheelchair  
User manual*



## How can you get in touch with Invacare®?

If you have any questions or need support, please contact your authorised Invacare® Dealer, who has the necessary know-how and equipment plus the special knowledge concerning your Invacare® product, and can offer you all-round satisfactory service. Should you wish to contact Invacare® directly, you can reach us in Europe at the following addresses and phone numbers.

<b>A</b>	<b>Invacare Austria GmbH</b> Herzog Odilostrasse 101 A-5310 Mondsee Austria	☎: Fax: @: WWW:	+43 6232 5 53 50 +43 6232 5 53 54 info@invacare-austria.com www.invacare.at
----------	--	--------------------------	--

<b>B</b>	<b>Invacare n.v.</b> Autobaan 22 B-8210 Loppem (Brugge)	☎: Fax: @: WWW:	+32 (0)50 83 10 10 +32 (0)50 83 10 11 belgium@invacare.com www.invacare.be
----------	---	--------------------------	---

<b>CH</b>	<b>Invacare AG</b> Benkenstraße 260 CH-4108 Witterswil Switzerland	☎: Fax: @: WWW:	+41 (0)61487 70 80 +41 (0)61487 70 81 switzerland@invacare.com www.invacare.ch
-----------	---	--------------------------	---

<b>D</b>	<b>Invacare Aquatec GmbH</b> Alemannenstraße 10 88316 Isny Deutschland	☎: Fax: @: WWW:	+49 (0)7562 70 00 +49 (0)7562 7 00 66 info@invacare-aquatec.com www.invacare-aquatec.de
----------	---	--------------------------	--

<b>DK</b>	<b>Invacare A/S</b> Sdr. Ringvej 37 DK-2605 Brøndby Danmark	☎ (Kundeservice): Fax (Kundeservice): @: WWW:	+45 (0)36 90 00 00 +45 (0)36 90 00 01 denmark@invacare.com www.invacare.dk
-----------	--	--	---

<b>E</b>	<b>Invacare® SA</b> c/ Areny s/n Polígon Industrial de Celrà E-17460 Celrà (Girona) ESPAÑA	☎: Fax: @: WWW:	+34 (0)972 49 32 00 +34 (0)972 49 32 20 contactsp@invacare.com www.invacare.es
----------	--	--------------------------	---

<b>F</b>	<b>Invacare® Poirier SAS</b> Route de St Roch F-37230 Fondettes <b>France</b>	☎: Fax: @: WWW:	+33 (0)247 62 64 66 +33 (0)247 42 12 24 contactfr@invacare.com www.invacare.fr
<b>GB</b>	<b>Invacare® Ltd</b> Pencoed Technology Park Pencoed Bridgend CF35 5HZ United Kingdom	☎ (Customer services): Fax (Customer services): @: WWW:	+44 (0)1656 77 62 22 +44 (0)1656 77 62 20 uk@invacare.com www.invacare.co.uk
<b>I</b>	<b>Invacare Mecc San s.r.l.</b> Via dei Pini, 62 I - 36016 Thiene (VI) <b>ITALIA</b>	☎: Fax: @: WWW:	+39 0445 38 00 59 +39 0445 38 00 34 italia@invacare.com www.invacare.it
<b>IE</b>	<b>Invacare Ireland Ltd.</b> Unit 5 Seatown Business Campus Seatown Rd, Swords County Dublin <b>Ireland</b>	☎: Fax: @: WWW:	+353 18 10 70 84 +353 18 10 70 85 ireland@invacare.com www.invacare.ie
<b>N</b>	<b>Invacare® AS</b> Grensesvingen 9 Postboks 6230 Etterstad N-0603 Oslo <b>Norge</b>	☎ (Kundeservice): Fax (Kundeservice): @: @: WWW:	+47 (0)22 57 95 00 +47 (0)22 57 95 01 norway@invacare.com island@invacare.com www.invacare.no
<b>NL</b>	<b>Invacare® B.V.</b> Celsiusstraat 46 NL-6716 BZ Ede <b>Nederland</b>	☎: Fax: @: @: WWW:	+31 (0)318 69 57 57 +31 (0)318 69 57 58 nederland@invacare.com csede@invacare.com www.invacare.nl
<b>P</b>	<b>Invacare Lda</b> Rua Estrada Velha, 949 P-4465-784 Leça do Balio Portugal	☎: ☎: Fax: @: WWW:	+351 225 10 59 46 +351 225 10 59 47 +351 225 10 57 39 portugal@invacare.com www.invacare.pt



**Aterförsäljare:**  
**Invacare® AB**  
Fagerstagatan 9  
S-163 91 Spånga  
**Sverige**

☎ (Kundtjänst): +46 (0)8 761 70 90  
Fax (Kundtjänst): +46 (0)8 761 81 08  
@: sweden@invacare.com  
@: finland@invacare.com  
WWW: www.invacare.se



**Tillverkare:**  
**Invacare® Deutschland GmbH**  
Kleiststraße 49  
D-32457 Porta Westfalica  
**Deutschland**

MÖLNDAL  
☎: +46 (0)31 86 36 00  
Fax: +46 (0)31 86 36 06  
@: ginvacare@invacare.com

LANDSKRONA  
☎: +46 (0)418 2 85 40  
Fax: +46 (0)418 1 80 89  
@: linvacare@invacare.com

OSKARSHAMN  
☎: +46 (0)491 1 01 40  
Fax: +46 (0)491 1 01 80  
@: oinvacare@invacare.com

---

**Eastern  
european  
countries**

**European Distributor  
Organisation (EDO)**  
Kleiststraße 49  
D-32457 Porta Westfalica  
**Deutschland**

☎: +49 (0)5731 75 45 40  
Fax: +49 (0)5731 75 45 41  
@: edo@invacare.com  
WWW: www.invacare.de

---

# Table of Contents

Chapter		Page
<b>1</b>	<b>Introduction</b>	<b>9</b>
1.1	Important symbols in this manual .....	11
1.2	Important symbols found on the vehicle .....	13
1.3	Type classification and permissible use.....	14
1.4	Guarantee .....	14
1.5	Indications.....	15
1.6	Life expectancy.....	15
<b>2</b>	<b>Safety notes</b>	<b>16</b>
2.1	General safety notes .....	16
2.2	Safety information for using the wheelchair as a piece of sports equipment .....	19
2.3	Safety information on electromagnetic interference .....	20
2.4	Safety information on driving and freewheel mode.....	21
2.5	Safety information regarding changes and modifications to the mobility device.....	23
<b>3</b>	<b>Key features</b>	<b>25</b>
<b>4</b>	<b>Getting in and out of the wheelchair</b>	<b>26</b>
4.1	Remove the standard armrest in order to side transfer .....	26
<b>5</b>	<b>Driving</b>	<b>28</b>
5.1	Before driving for the first time.....	28
5.2	Parking and stationary.....	29
5.3	Taking Obstacles .....	29
5.3.1	Maximum obstacle height .....	29

5.3.2	Safety information when ascending obstacles .....	29
5.3.3	The correct way to overcome obstacles .....	30
<b>5.4</b>	<b>Driving up and down gradients.....</b>	<b>31</b>
<b>5.5</b>	<b>Use on public roads .....</b>	<b>32</b>
<b>6</b>	<b>Pushing the wheelchair in freewheel mode .....</b>	<b>32</b>
6.1	Disengaging Motors .....	32
<b>7</b>	<b>Remotes .....</b>	<b>33</b>
<b>8</b>	<b>Adjusting the wheelchair to the user's seating posture .....</b>	<b>34</b>
8.1	<b>Adjusting the armrests and the control panel.....</b>	<b>34</b>
8.1.1	Adapting the control panel to the length of the user's arm.....	34
8.1.2	Setting the height of the remote .....	35
8.1.3	Setting the height of the armrests.....	36
8.1.4	Adjusting the width of the armrests .....	37
8.2	<b>Adjusting the seat angle / seat height.....</b>	<b>39</b>
8.2.1	Manual adjustment using perforated plates.....	39
8.3	<b>Adjusting the backrest.....</b>	<b>43</b>
8.3.1	Adjusting the backrest manually .....	43
8.4	<b>Adjusting the headrest.....</b>	<b>44</b>
8.5	<b>Postural belts .....</b>	<b>45</b>
8.5.1	Types of postural belts.....	45
8.5.2	Adjusting the postural belt correctly.....	47
8.6	<b>Legrests.....</b>	<b>47</b>
8.6.1	Standard footrest with pre-set angle.....	47
8.6.1.1	Swivelling the footrest outward and/or removing.....	47
8.6.1.2	Setting the angle.....	48
8.6.1.3	Setting the end stop of the footrest .....	50
8.6.1.4	Adjusting the length of the footrest.....	53
8.6.2	Manually height adjustable legrest 90° - 0° .....	54

8.6.2.1	Swivelling the legrest outward and/or removing.....	54
8.6.2.2	Setting the angle.....	55
8.6.2.3	Setting the end stop of the legrest.....	59
8.6.2.4	Adjusting the length of the legrest.....	64
8.6.2.5	Adjusting the depth of the calf plate.....	65
8.6.2.6	Adjusting the height of the calf plate.....	66
8.6.2.7	Unlocking and swivelling the calf plate backward when alighting.....	67
8.6.2.8	Adjusting the angle adjustable foot plate.....	68
8.6.2.9	Adjusting the angle and depth adjustable foot plate.....	69
<b>9</b>	<b>Electrical system</b>	<b>70</b>
9.1	<b>Electronics protection system</b> .....	<b>70</b>
9.1.1	The main fuse.....	71
9.2	<b>Batteries</b> .....	<b>72</b>
9.2.1	What you need to know about batteries.....	72
9.2.2	Charging the batteries.....	74
9.2.3	Removing and fitting batteries.....	76
9.2.3.1	Removing the batteries.....	77
9.2.3.2	How to handle damaged batteries correctly.....	79
<b>10</b>	<b>Care and maintenance</b>	<b>80</b>
10.1	<b>Safety checks that should be performed by the user</b> .....	<b>81</b>
<b>11</b>	<b>Repair Instructions</b>	<b>83</b>
11.1	<b>Repairing a flat tyre</b> .....	<b>83</b>
11.1.1	Repairing a flat tyre at the back (tyre type 3.00-8").....	84
<b>12</b>	<b>Transport</b>	<b>87</b>
12.1	<b>Transferring the wheelchair to a vehicle</b> .....	<b>87</b>
12.2	<b>Securing the wheelchair for transport without passengers</b> .....	<b>88</b>
<b>13</b>	<b>Refurbishment</b>	<b>89</b>

<b>14</b>	<b>Disposal</b>	<b>90</b>
<b>15</b>	<b>Technical specifications</b>	<b>91</b>
<b>16</b>	<b>Inspections Performed</b>	<b>94</b>



# 1 Introduction

**Dear user,**

First we would like to thank you for purchasing our product! We hope that you will have a great deal of pleasure with your new power wheelchair.

**This operating manual contains important information and notes about:**

- **Safety**
- **Operation**
- **Care and maintenance**

**Please take care to read the operating manual thoroughly before starting out on your first journey.**

This wheelchair has been constructed for a large circle of users with different requirements.

The decision whether the model is suitable for the user may only be taken by medical specialists with appropriate expertise.

Invacare® or their statutory representatives can accept no liability in cases in which the wheelchair has not been adapted to suit the users' handicaps.

Some maintenance and settings can be performed by the user or his/hers attendants. Certain adjustments do however require technical training and may only be carried out by your Invacare® specialist dealer. Damages and errors caused by nonobservance of the operating manual or as a result of incorrect maintenance are excluded from all guarantees.

This manual contains copyrighted information. This manual may not be reproduced or reprinted either partly or completely without previous written consent from Invacare® or its statutory representatives. We reserve the right to make any necessary alterations on the grounds of technical improvements.

## 1.1 Important symbols in this manual

---



### **General risks**

**This symbol warns you of general hazards!**

- *Always follow the instructions to avoid injury to the user or damage to the product.*
- 



### **EXPLOSION HAZARD!**

**This symbol warns you of an explosion hazard, which can be caused by excessive tyre pressure in a pneumatic tyre.**

- *Always follow the instructions to avoid injury to the user or damage to the product.*
- 



### **BURN HAZARD!**

**This symbol warns you of the danger of chemical burns, for example due to the discharge of battery acids!**

- *Always follow the instructions to avoid injury to the user or damage to the product.*
- 



### **BURN Risk!**

**This symbol warns of the risk of burns, for example, as a result of hot motor surfaces.**

- *Follow the instructions in order to avoid injury or damage to the product.*
- 



### **RISK OF CRUSHING!**

**This symbol warns of a risk of crushing caused by being careless with heavy components.**

- *Always follow the instructions to avoid injury to the user or damage to the product.*
-



---

**Wear eye protection**

This symbol refers to the requirement for wearing eye protection, for example when working with batteries.

- *You must wear safety goggles when this symbol is displayed.*
- 



---

**Wear protective gloves**

This symbol indicates the requirement to wear protective gloves, for example when working with batteries.

*You must wear protective gloves when this symbol is displayed.*

---



---

**NOTE:**

This symbol identifies general information which is intended to simplify working with your product and which refers to special functions.

---



---

**Requirements:**

- This symbol identifies a list of various tools, components and items which you will need in order to carry out certain work. Please do not attempt to carry out the work if you do not have the listed tools available.
- 



---

**READ WELL BEFORE OPERATION!**

This symbol advises you to read information carefully.

---

## 1.2 Important symbols found on the vehicle



---

**This product has been supplied from an environmentally aware manufacturer. This product may contain substances that could be harmful to the environment if disposed of in places (landfills) that are not appropriate according to legislation.**

- *The 'crossed out wheelee bin' symbol is placed on this product to encourage you to recycle wherever possible.*
  - *Please be environmentally responsible and recycle this product through your recycling facility at its end of life.*
-

## 1.3 Type classification and permissible use

This vehicle was designed for persons whose ability to walk is impaired, but who are still in terms of their eyesight and physically and mentally able to operate an electric vehicle. It has been classified according to EN 12184 as a **class B mobility product** (for indoor and outdoor areas). It is therefore compact and agile enough for indoor areas, but also able to overcome many obstacles in outdoor areas.

You can find exact information on speed, turning radius, range, safe climbing ability, maximum obstacle height and permissible operating conditions in chapter "Technical specifications" starting from page 91.

Please also pay attention to all safety information in chapter "Safety notes" starting from page 16.

The vehicle was successfully tested according to German and international standards as to its safety. It satisfies the requirements according to DIN EN 12184 including EN 1021-1/-2. It was also tested successfully according to EN60529 IPX4 as to its resistance to spray water, and is therefore well suited for typical middle European weather conditions. When equipped with an appropriate lighting system, the vehicle is suitable for use on public roads.

Under certain circumstances, this vehicle can be used as a piece of sports equipment. Make sure to comply with all safety information in section "**Safety information for using the wheelchair as a piece of sports equipment**" starting on page 19.

## 1.4 Guarantee

The terms and conditions of the guarantee are part of the general terms and conditions particular to the individual countries in which this product is sold.

## 1.5 Indications

The use of this mobility product is recommended for the following indications:

- The inability or a greatly restricted ability to walk within the scope of the basic requirement to be able to move within one's own four walls.
- The need to leave the dwelling place in order to get some fresh air during a short walk or to reach those places generally to be found at close distance to the dwelling and where everyday business is carried out.
- The use of the electric wheelchair for taking part in athletic activities (after corresponding modifications).

Provision of electric wheelchairs for interior and exterior areas is advisable if the use of hand-operated wheelchairs is no longer possible on account of the disability, yet proper operation of an electromotive drive unit is still practicable.

## 1.6 Life expectancy

We estimate a life expectancy of five years for this product, provided it is used in strict accordance with the intended use as set out in this document and all maintenance and service requirements are met. The estimated life expectancy can be exceeded if the product is carefully used and properly maintained, and provided technical and scientific advances do not result in technical limitations. The life expectancy can also be considerably reduced by extreme or incorrect usage. The fact that we estimate a life expectancy for this product does not constitute an additional warranty.

## 2 Safety notes



---

**READ WELL BEFORE OPERATION!**

---

### 2.1 General safety notes

---



**Danger of injury if mobility device is used in any other way than the purpose described in this manual!**

- *Only ever use the mobility device in accordance with the instructions in this User's Manual (see chapter "Type classification and permissible use" on page 14).*
- *Pay strict attention to the safety information.*

**Danger of injury if the mobility device is driven when ability to operate a vehicle is impaired by medication or alcohol!**

- *Never drive the mobility device under the influence of medication or alcohol. If necessary, the mobility device must be operated by an attendant who is physically and mentally able.*

**Danger of damage or injury if mobility device is accidentally set into motion!**

- *Switch the mobility device off before you get in, get out or handle unwieldy objects.*
  - *When the drive is disengaged, the brake inside the drive is deactivated. For this reason, pushing the mobility device by an attendant is only recommended on flat surfaces, never on gradients. Never leave your mobility device on a gradient with its motors disengaged. Always re-engage the motors immediately after pushing the mobility device (see chapter "Pushing the wheelchair in freewheel mode" on page 32).*
-





---

**Danger of injury if the mobility device is switched off while driving, for example by pressing the On/Off Button or disconnecting a cable, due to it coming to an abrupt, sharp stop!**

- *If you have to brake in an emergency, simply release the joystick which will bring you to a halt. (refer to the joystick operating manual for more information).*

**Danger of injury when transferring mobility device to a vehicle for transport with the occupant seated in it!**

- *It is always better to transfer the mobility device to a vehicle without the occupant seated in it.*
- *If the mobility device needs to be loaded up a ramp together with its driver, ensure that the ramp does not exceed the maximum safe slope (see chapter "Technical specifications" from page 91).*
- *If the mobility device does need to be loaded using a ramp which exceeds the maximum safe slope (see chapter "Technical specifications" from page 91), then you must use a winch. An attendant can safely monitor and assist the loading process.*
- *As an alternative you can use a platform lift. Ensure that the total weight of the mobility device including the user does not exceed the maximum permissible weight for the platform lift or winch if you are using.*

**Danger of injury if maximum permissible load is exceeded!**

- *Do not exceed the maximum permissible load (see chapter "Technical specifications" from page 91).*
  - *The mobility device is only designed for use by a single occupant whose maximum weight does not exceed the maximum permissible load of the device. Never use the mobility device to transport more than one person.*
-



---

**Danger of injury due to wrong lifting or dropping of heavy components!**

- *When maintaining, servicing or lifting any part of your mobility device, take into account the weight of the individual components especially the batteries. Be sure at all times to adopt the correct lifting posture and ask for assistance if necessary.*

**Danger of falling out of the mobility device.**

- *Do not slide forward on the seat, do not lean forward between your knees, do not lean backwards out over the top of the backrest, for example to reach an object.*
- *If a posture belt is installed, it should be correctly adjusted and used each time you use the mobility device.*
- *When transferring to a different seat, position the mobility device as close as possible to the new seat.*

**Danger of injury by moving parts!**

- *Make sure that no injury is incurred by moving parts of the mobility device, like wheels or one of the Lifter Modules (if fitted), especially when children are around.*

**Risk of injury from hot surfaces!**

- *Do not leave the wheelchair in direct sunlight for prolonged periods. Metal parts and surfaces such as the seat and armrests can become very hot.*

**Danger of fire or breaking down due to electric devices being connected!**

- *Do not connect any electric devices to your mobility device that are not expressly certified by Invacare® for this purpose. Have all electrical installations done by your authorised Invacare® Dealer.*
-

## 2.2 Safety information for using the wheelchair as a piece of sports equipment



---

### **SAFETY INFORMATION ON THE USE OF THE WHEELCHAIR AS A PIECE OF SPORTS EQUIPMENT – PLEASE MAKE SURE TO READ FIRST!!**

The following chapter contains safety information, which is meant to ensure the safe use of the wheelchair in everyday situations. The safety of the user, but also of other persons who might be in the vicinity of wheelchair, is the main focus of this information. Therefore, it is of the utmost importance to follow these instructions.

When using the wheelchair as a piece of sports equipment, the situation can be slightly different. In this situation also, the safety of bystanders and spectators should be of primary importance to the organizers of the sporting event and the participating athletes. At the same time, the athletes knowingly expose themselves to an increased risk of injury, and the wheelchair is also subjected to greater stress and wear.

An athlete must know and understand these risks. A wheelchair user who would like to participate in a sporting event with his wheelchair, should do so only after consulting a physician! It is at the sole discretion of the physician to decide whether participation in a particular sport would be advisable or not. Afterwards, it is the responsibility of the wheelchair user himself to judge risks correctly and to act accordingly.

**Invacare® can not be held responsible in case of injury to the user or other persons, and will provide no warranty in case of damage to the wheelchair, which result from increased wear on account of it being used as a piece sports equipment!**

---

## 2.3 Safety information on electromagnetic interference

This electric vehicle was successfully tested in accordance with International standards as to its compliance with Electromagnetic Interference (EMI) Regulations. However, electromagnetic fields, such as those generated by radio and television transmitters, and cellular phones, can influence the functions of electric vehicles. Also, the electronics used in our vehicles can generate a low level of electromagnetic interference, which however will remain within the tolerance permitted by law. For these reasons we ask you to please observe the following precautions:



---

**WARNING: Danger of malfunction due to electromagnetic interference!**

- *Do not switch on or operate portable transceivers or communication devices (such as radio transceivers or cellular phones) when the vehicle is switched on.*
  - *Avoid getting near strong radio and television transmitters.*
  - *In case the vehicle should be set in motion unintentionally or the brakes are released, switch it off immediately.*
  - *Adding electrical accessories and other components or modifying the vehicle in any way can make it susceptible to electromagnetic interference. Keep in mind that there is no sure way to determine the effect such modifications will have on the overall immunity of the electronic system.*
  - *Report all occurrences of unintentional movement of the vehicle, or release of the electric brakes to the manufacturer.*
-

## 2.4 Safety information on driving and freewheel mode

---



### **Danger of injury if the wheelchair tips over!**

- *Inclines and declines can only be travelled up to the maximum safe slope (see chapter "Technical specifications" from page 91).*
  - *Always return the backrest of your seat or the seat tilt to an upright position before ascending slopes. We recommend that you position the seat backrest and the seat tilt (if fitted) slightly to the rear before descending slopes.*
  - *Only ever drive downhill at a maximum of 2/3 of the top speed. Avoid abrupt braking or accelerating on gradients.*
  - *If at all possible, avoid driving on slippery surfaces (such as snow, gravel, ice etc.) where there is a danger of you losing control over the vehicle, especially on a gradient. If driving on such a surface is inevitable, then always drive slowly and with the utmost caution.*
  - *Never attempt to overcome an obstacle when on an uphill or downhill gradient.*
  - *Never attempt to drive up or down a flight of steps with your wheelchair.*
  - *When overcoming obstacles, always observe the maximum obstacle height (see chapter "Technical specifications" from page 91 and information about overcoming obstacles in chapter "Taking Obstacles" from page 29).*
  - *Avoid shifting your centre of gravity as well as abrupt joystick movements and changes of direction when the wheelchair is in motion.*
  - *Never use the wheelchair to transport more than one person.*
  - *Do not exceed the overall maximum permissible load or the maximum load per axle (see chapter "Technical specifications" on page 91).*
  - *Note that the wheelchair will brake or accelerate if you change the Driving Mode whilst the wheelchair is in motion.*
-



---

**Danger of breaking down in adverse weather conditions, i.e. extreme cold, in an isolated area!**

- *If you are a user with severely limited mobility, we advise that in the case of adverse weather conditions DO NOT attempt a journey without an accompanying attendant!*

**Danger of injury if your foot slides off the footrest and gets caught underneath the wheelchair when it is in motion!**

- *Make sure each time before you drive the wheelchair that your feet are squarely and securely in place on the footplates, and that both legrests are properly locked into place.*

**Danger of injury if you collide with an obstacle when driving through narrow passages such as doorways and entrances!**

- *Drive through narrow passages in the lowest driving mode and with due caution.*

**If your power wheelchair has been fitted with angle-adjustable legrests, there is a danger of personal injury and damage to the wheelchair if you drive the wheelchair with the legrests raised!**

- *To avoid unwanted displacement of the wheelchair centre of gravity to the front (especially when travelling downhill) and in order to avoid damage to the wheelchair, angle-adjustable legrests must always be lowered during normal travelling.*
- 



---

**CAUTION: Danger of tipping! Anti tip wheels (stabilisers) are only effective on firm ground! They sink in on soft ground such as grass, snow or mud if the electrical vehicle rests itself on them. They lose their effect and the electrical vehicle can tip over.**

- *Only drive with extreme care on soft ground, especially during uphill and downhill journeys. In the process pay increased attention to the tip stability of the electric vehicle.*
-

## 2.5 Safety information regarding changes and modifications to the mobility device

---



### **CE marking of the wheelchair**

The conformity assessment/ CE marking was carried out in accordance with Directive 93/42 EEC / MPG (Medical Devices Act) and only applies to the complete product.

The CE marking is invalidated if components or accessories are replaced or added that have not been approved for this product by Invacare.

In this case, the company that adds or replaces the components or accessories is responsible for the conformity assessment/ CE marking or for registering the wheelchair as a special design and for the relevant documentation.

---



---

**CAUTION: Danger of injuries and damage to mobility aid due to unapproved components and accessory parts!**

**Seating systems, additions and accessory parts which have not been approved by Invacare® for use with this mobility aid can affect the tipping stability and increase tipping hazards!**

- *Only ever use seating systems, additions and accessory parts which have been approved by Invacare® for this mobility aid!*

**Seating systems which are not approved by Invacare® for use with this power wheelchair do not, under certain circumstances, comply with the valid standards and could increase the flammability and the risk of skin irritation.**

- *Only use seating systems that have been approved by Invacare® for this power wheelchair.*

**Electrical and electronic components which have not been approved by Invacare® for use with this mobility aid can cause fire hazards and lead to electromagnetic damage!**

- *Only ever use electrical and electronic components which have been approved by Invacare® for this mobility aid!*

**Batteries which have not been approved by Invacare® for use with this mobility aid can cause chemical burns!**

- *Only ever use batteries which have been approved by Invacare® for this mobility aid!*
-



### 3 Key features

- 1) Sliding handle
- 2) Set screw for adjusting the height of the remote
- 3) Set screw for adjusting the angle of the backrest
- 4) Disengaging lever
- 5) Remote
- 6) Release button of the legrest



## 4 Getting in and out of the wheelchair



---

**Important information for getting into and out of the wheelchair from the side!**  
The armrest must be removed in order to get into or out of the wheelchair from the side.

---

### 4.1 Remove the standard armrest in order to side transfer

#### Removing the armrest:

- Disengage the release handle (1).
- Pull the side part out of its holder.



### **Getting into the wheelchair:**

- Position your wheelchair as close as possible to your seat. This might have to be done by an attendant.
- Switch your wheelchair off.
- Apply the manual wheel lock of your wheelchair (if existing).
- Detach the skirt guard of your wheelchair or swivel it up.
- Now slide into the wheelchair.



### **Getting out of the wheelchair:**

- Drive your wheelchair as close as possible to your seat.
- Switch your wheelchair off.
- Apply the manual wheel lock of your wheelchair (if existing).
- Detach the skirt guard of your wheelchair or swivel it up.
- Now slide onto your new seat.



---

#### **NOTE:**

If you do not have sufficient muscle strength, you should ask other persons for help. Use a sliding board, if possible.

---

## 5 Driving

---



### NOTE

The maximum load capacity that is stated in the technical data only states that the system is designed for this mass in total. However, this does not mean that one can sit a person with this body weight in the wheelchair without restrictions. Attention must be paid to the body proportions, such as height, weight distribution, abdominal girth, leg and calf girth and seat depth. These factors have a strong influence on driving features such as tilt stability and traction. The permissible axle loads in particular must be adhered to (see chapter "**Technical specifications**" as from page 91)! It may possibly be necessary to carry out adaptations to the seat system.

---

### 5.1 Before driving for the first time...

Before you take your first trip, you should familiarise yourself well with the operation of the vehicle and with all operating elements. Take your time to test all functions and driving modes.

---



### NOTE:

If installed, make sure to properly adjust and use the postural belt each time you use the wheelchair.

---

#### **Sitting Comfortably = Driving Safely**

**Before each trip, make sure that:**

- **You are within easy reach of all operating controls.**
- **The battery charge is sufficient for the distance intended to be covered.**
- **The postural belt (if installed) is in perfect order.**

- The rear mirror (if installed) is adjusted so you can look behind at all times without having to bend forward or shift your seating position.

## 5.2 Parking and stationary

**When parking your vehicle or if your vehicle is stationary for a prolonged period:**

- Switch the vehicle's power system off (ON-/OFF key).
- Activate your anti-theft lock, if existing.

## 5.3 Taking Obstacles

### 5.3.1 Maximum obstacle height

You can find information about maximum obstacle heights in the chapter entitled "**Technical specifications**" from page 91.

### 5.3.2 Safety information when ascending obstacles



**CAUTION: Danger of Tipping Over!**

- *Never approach obstacles at an angle but at 90 degrees as shown below.*
  - *Put your backrest into an upright position before climbing an obstacle.*
- 



**WARNING: Danger of destruction of the front castor forks!**

- *Your wheelchair was designed for use as a piece of sports equipment, and is therefore equipped with smaller front castors and lighter forks for better maneuverability, which can be easily damaged if misused. Never attempt to overcome obstacles, such as kerbs, with momentum, but rather slowly and with the utmost caution!*
-

### 5.3.3 The correct way to overcome obstacles

#### Ascending and descending

The same approach applies to both ascending and descending obstacles:

- Approach the obstacle or the kerb slowly and at a right angle.
- Stop shortly before the front wheels come into contact with the obstacle.
- Check the position of the front wheels. They must be in driving direction and at right angles to the obstacle.
- Approach slowly and keep at a consistent speed until the rear wheels have also passed over the obstacle.

**Right**



**Wrong**



## 5.4 Driving up and down gradients

For information concerning the maximum safe slope, please see chapter "**Technical specifications**" starting on page 91.



---

### **WARNING: Danger of tipping over!**

- *Only ever drive downhill at a maximum of 2/3 of the top speed. Avoid sudden changes of direction or abrupt braking when driving on slopes.*
  - *Always return the backrest of your seat or the seat tilt (if adjustable seat tilt is available) to an upright position before ascending slopes. We recommend that you position the seat backrest or the seat tilt slightly to the rear before descending slopes.*
  - *Always lower the lifter (if fitted) to its lowest position before ascending or descending a slope.*
  - *Never attempt to ascend or descend a slope on slippery surfaces or where there is a danger of skidding (such as wet pavement, ice etc).*
  - *Avoid trying to get out of the vehicle on an incline or a gradient.*
  - *Always drive straight in the direction the road or path you are on goes, rather than attempting to zigzag.*
  - *Never attempt to turn around on an incline or a slope.*
- 



---

### **Braking distance is much longer on a downhill slope than on even terrain!**

- *Never drive down a slope that exceeds the maximum safe slope (see chapter "**Technical specifications**" on page 91).*
-

## 5.5 Use on public roads

If you wish to use your wheelchair on public roads and lighting is required by national legislation, then your wheelchair needs to be equipped with an appropriate lighting system.

Please contact your Invacare ® dealer if you have any questions.

## 6 Pushing the wheelchair in freewheel mode

The motors of the wheelchair are equipped with automatic brakes, preventing that the wheelchair starts rolling out of control when the joystick box is switched off. When pushing the wheelchair manually whilst freewheeling, the magnetic brakes must be disengaged.

### 6.1 Disengaging Motors



---

#### **Danger of the vehicle running away!**

- *When the motors are disengaged (for push operation whilst freewheeling), the electromagnetic motor brakes are deactivated! When the vehicle is parked, the levers for engaging and disengaging the motors must without fail be locked firmly into the "DRIVE" position (electromagnetic motor brakes activated)!*
- 



---

#### **NOTE:**

The motors may only be disengaged by an attendant, not by the user!

This ensures that the motors are only disengaged if an attendant is available to secure the wheelchair and prevent unintended rolling.

---

The lever for disengaging the motors is on the rear right side on the wheelchair chassis.



**Declutching the motors:**

- Switch off the remote.
- Pull the locking pin (1, on the underside of the declutching mechanism, not visible in the picture). Pull the coupling lever to the rear (2). The motors are declutched.

**Reclutching the motors:**

- Push the coupling lever (2) to the front. The motors are redeclutched.



## 7 Remotes

Your wheelchair may be equipped with one of several different remotes. For information on the different functions and how to operate a particular remote, please see it's corresponding User Manual.

## 8 Adjusting the wheelchair to the user's seating posture

### 8.1 Adjusting the armrests and the control panel

#### 8.1.1 Adapting the control panel to the length of the user's arm

- Loosen the wing screw (1).
- Set the remote to the desired length by pushing forward or backward.
- Re-tighten the screw.



## 8.1.2 Setting the height of the remote

- Loosen the wing screw (1).
- Set the remote to the desired height.
- Re-tighten the screw.



### 8.1.3 Setting the height of the armrests



---

**Requirements:**

- Allen key 3 mm
- 
- Use the Allen key 3 mm to loosen the screw (1).
  - Set the armrest at the desired height.
  - Re-tighten the screw.



## 8.1.4 Adjusting the width of the armrests

The distance between the side sections can be adjusted by 5.5 cm on both sides (11 cm in total).

---



### Requirements:

- Allen key 8 mm
- 

### Where to find the adjustment screws

The picture below shows the position of the screws (1) that enable adjustment to the width of the armrests.

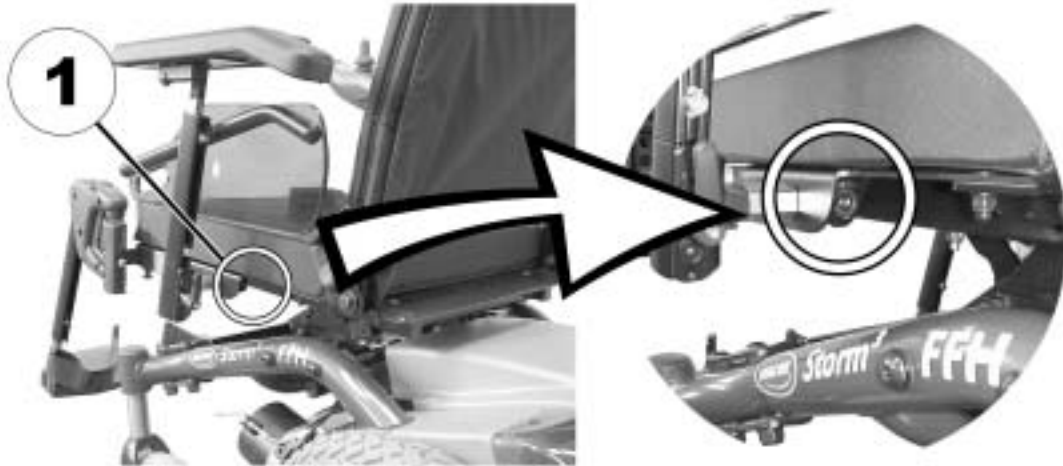

### Doing the adjustment

- Loosen the screw (1).
- Set the armrest in the desired position.
- Re-tighten the screw.
- Check that the armrest is fastened firmly.
- Repeat the procedure for the other armrest.



## 8.2 Adjusting the seat angle / seat height

### 8.2.1 Manual adjustment using perforated plates

There are three perforated plates underneath the seat for adjusting the seat angle and the seat height. These perforated plates in connection with the adjustable rear holding plates result in a multitude of different setting possibilities.

The adjustment range of the seat height is 42.5 cm to 50 cm. The adjustment range of the seat angle is 22°. Please note: The higher the seat setting, the smaller the adjustment range of the seat angle!



---

**Pre-requisites:**

- 5 mm Allen key
  - 6 mm Allen key
  - 13 mm open-ended spanner
  - Torque wrench
-

- The picture at right shows the position of the perforated metal plates (1) and the fixation bolts (2) of the retaining plates for adjusting the seat height and seat angle.

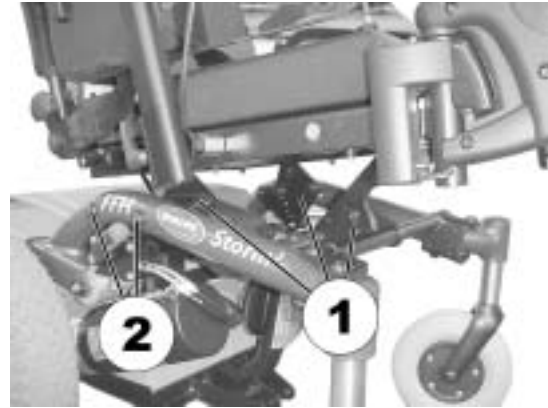

The picture at right shows the front perforated metal plates. The procedure is similar for the rear perforated metal plates. To adjust the front perforated metal plates, an open-end spanner 13 mm is needed in addition to the Allen key 5 mm.

- To adjust the seat height/seat angle, loosen and remove the bolt (1), using the spanner.
- Adjust the perforated metal plates to the desired height/angle.
- Re-position the bolts again and tighten with the spanner to 40 Nm.





Additionally, the seat height and angle can be adjusted using the rear retaining plates.

- Loosen the rear fixation bolt on one side (in threaded bushing 1), so that the retaining plate can be swiveled upward or downward.
- Loosen and remove the front fixation bolt (depending on the position, the bolt is either located in threaded bushing 2 or 3).
- Repeat the procedure on the other side.
- Low adjustment = hole combination 1 and 2.
- High adjustment = hole combination 1 and 3.
- Re-position and tighten the screws.

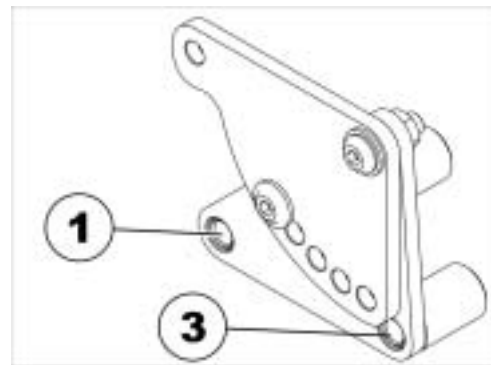
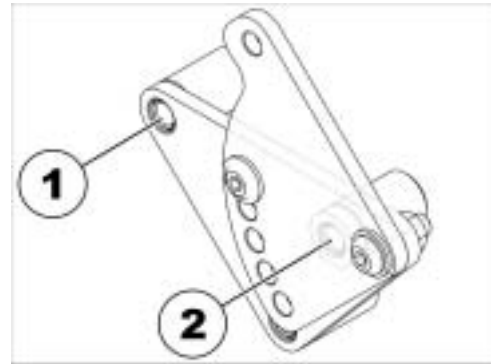

The adjustable rear perforated metal plates have five positions. These are indicated by the letters A to E in the illustration at right.

When the retaining plates are in the lower position (see above), then all five adjustments can be used. In the high position, only adjustments B, C, D and E are possible! When using A, the retaining plate collides with the seat frame.

This results in the following possible seat heights:

**Retaining plate in the lower position:**

Position of the perforated metal plate / seat height:

- A / 45.,5 cm
- B / 47 cm
- C / 47 cm
- D / 48 cm
- E / 48.5 cm

**Retaining plate in the high position:**

Position of the perforated metal plate / seat height:

- B / 42 cm (at 6° seat angle)
- C / 50 cm
- D / 51 cm
- E / 53 cm

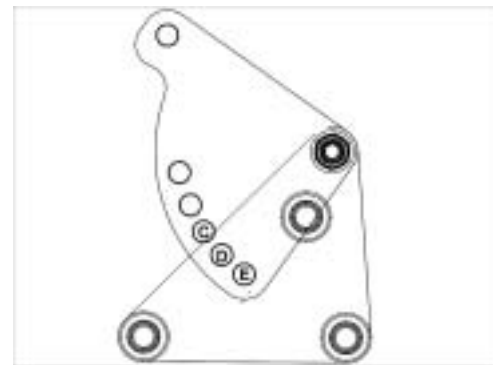
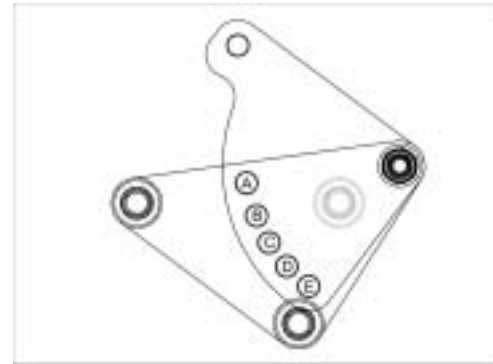

## 8.3 Adjusting the backrest

### 8.3.1 Adjusting the backrest manually

The angle of the backrest has six positions, from  $-10^{\circ}$  to  $+30^{\circ}$ .

- Loosen and remove the knurled screws (1) on both sides.
- The backrest is adjusted by selecting a combination of one of the two drill holes in the backrest frame and one of the sechs drill holes in the fixation plate.
- Re-position and tighten the screws.



## 8.4 Adjusting the headrest

- Loosen the clamping lever (1, 2 or 3).
- Adjust the headrest to the required position.
- Retighten clamping lever.



## 8.5 Postural belts

A postural belt is an option which can either be fixed to the wheelchair ex-works or can be retrofitted by your specialist dealer. If your wheelchair is fitted with a postural belt, your specialist dealer will have informed you about fitting and usage.

The postural belt is used to help the wheelchair user keep an optimum sitting position. Correct use of the belt assists the user in sitting securely, comfortably and well-positioned in the wheelchair, especially for such users who do not have such a good sense of balance while sitting.



---

**NOTE:**

We recommend using the postural belt whenever the wheelchair is used. The belt should be tight enough to ensure that you are sitting comfortably and that your body is in the correct sitting position.

---

### 8.5.1 Types of postural belts

Your wheelchair can be fitted with the following postural belt types ex-works. If your wheelchair has been fitted with a different belt to those listed below, please ensure that you have received the manufacturer's documentation with regard to correct fitting and use.

**Belt with metal buckle, adjustable one side**

Belt can only be adjusted on one side which can result in the buckle not sitting centrally.



**Belt with metal buckle, adjustable both sides**

Belt can be adjusted on both sides. This means that the buckle can be centrally positioned.



**Harness with metal buckle, adjustable on both sides**

Harness can be adjusted on both sides. This ensures that the buckle is always centrally positioned.

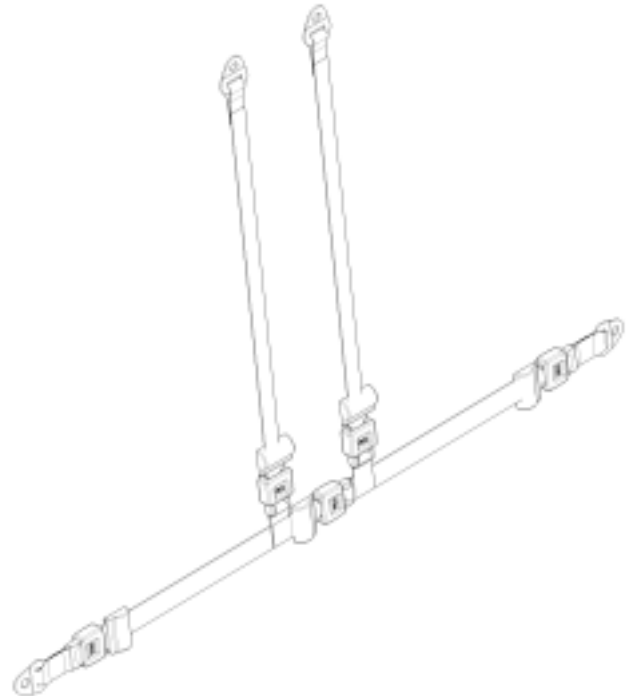

## **8.5.2 Adjusting the postural belt correctly**

- Ensure that you are sitting correctly, which means that you are sitting right at the back of the seat, your pelvis is positioned erect and as symmetrically as possible, not to the front, to the side or at one edge of the seat.
- Position the postural belt so that your hipbones can be easily felt above the belt.
- Adjust the belt length using one of the adjustment aids described above. The belt should be adjusted so that you can fit a flat hand between the belt and your body.
- The buckle should be positioned as centrally as possible. In doing so, please carry out adjustments on both sides as much as possible.
- Please check your belt every week to ensure that it is still in good working condition; to ensure it has no damage or wear, and that it is fixed properly to the wheelchair. If the belt is only fastened with a bolted connection, ensure that the connection has not loosened or undone. You can find more information about maintenance work on belts in the service manual, which is available from Invacare®.

## **8.6 Legrests**

### **8.6.1 Standard footrest with pre-set angle**

#### **8.6.1.1 Swivelling the footrest outward and/or removing**

The small unlocking button is located on the upper section of the footrest. When the footrest is unlocked, it can be swivelled inward or outward when getting into the wheelchair as well as being removed completely.

- Press the unlocking button (1) and swivel the footrest outward.
- Remove the footrest in an upward direction.



### 8.6.1.2 Setting the angle



---

**PLEASE NOTE: Danger of injury due to incorrect adjustment of the footrests and legrests.**

- *Before and during every journey it is imperative to ensure that the legrests contact neither the castor wheels nor the ground!*
- 



---

**Pre-requisites:**

- 1x 6 mm Allen key
-



- Loosen the screw (1) using the Allen key.
- If the footrest cannot be moved after loosening the screw, position a metal pin in the designated borehole (2) and use a hammer to knock on this lightly. The clamping mechanism in the interior of the footrest will be released by this. Repeat the procedure from the other side of the footrest if necessary.



- Loosen the screw (1) using the Allen key.
- Set the desired angle.
- Re-tighten the screw.



### 8.6.1.3 Setting the end stop of the footrest



---

**Pre-requisites:**

- 1x 6 mm Allen key
  - 1x 10 mm open-ended spanner
- 

The end position of the footrest is determined by means of a rubber stop (1).



The rubber stop can be screwed in or out (A) or pushed up or down (B).



- Use the Allen key to loosen the screw (1) and swivel the footrest upward in order to access the rubber stop.



- Use the open-ended spanner to loosen the counternut (1).



- Move the rubber stop to the desired position
- Re-tighten the counternut



- Move the footrest to the desired position.
- Re-tighten the screw.



#### 8.6.1.4 Adjusting the length of the footrest



---

**PLEASE NOTE: Danger of injury due to incorrect adjustment of the footrests and legrests.**

- *Before and during every journey it is imperative to ensure that the legrests contact neither the castor wheels nor the ground!*
- 



**Pre-requisites:**

- 1x 5 mm Allen key
- 

- Use the spanner to loosen the screw (1).
- Adjust to the desired length.
- Re-tighten the screw.



## 8.6.2 Manually height adjustable legrest 90° - 0°

### 8.6.2.1 Swivelling the legrest outward and/or removing

The small unlocking button is located on the upper section of the legrest. When the legrest is unlocked, it can be swivelled inward or outward when getting into wheelchair as well as being removed completely.

- Press the unlocking button (1) and swivel the legrest outward.
- Remove the legrest in an upward direction.



### 8.6.2.2 Setting the angle



---

**PLEASE NOTE: Danger of injury due to incorrect adjustment of the footrests and legrests.**

- *Before and during every journey it is imperative to ensure that the legrests contact neither the castor wheels nor the ground!*
- 

- Loosen the locking knob (1) counter-clockwise at least one turn.

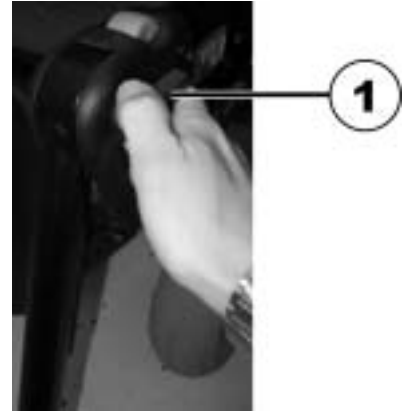

- Hit the knob to release the locking mechanism.

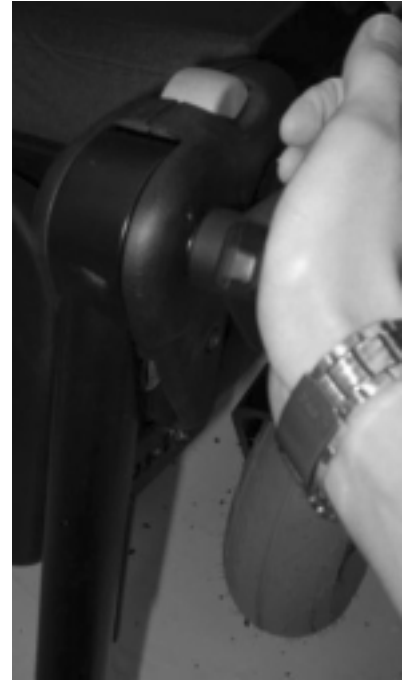



- Adjust the legrest to the desired angle.



- Tighten the knob clockwise.



### 8.6.2.3 Setting the end stop of the legrest



---

**Pre-requisites:**

- 1x 10 mm open-ended spanner
- 

The end position of the legrest is determined by means of a rubber stop (A).



The rubber stop can be screwed in or out (A) or pushed up or down (B).



- Loosen the locking knob (1) counter-clockwise at least one turn.

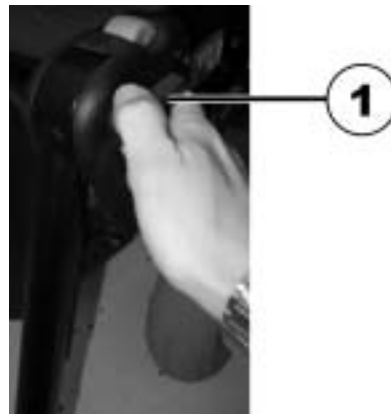

- Hit the knob to release the locking mechanism.



- Swivel the legrest upward in order to access the rubber stop.



- Use the open-ended spanner to loosen the counternut (1).



- Move the rubber stop to the desired position
- Re-tighten the counternut



- Move the legrest to the desired position.
- Re-tighten the locking knob.



#### 8.6.2.4 Adjusting the length of the legrest



---

**PLEASE NOTE: Danger of injury due to incorrect adjustment of the footrests and legrests.**

- *Before and during every journey it is imperative to ensure that the legrests contact neither the castor wheels nor the ground!*
- 



**Pre-requisites:**

- 1x 6 mm Allen key
- 

- Use the spanner to loosen the screw (1).
- Adjust to the desired length.
- Re-tighten the screw.





### 8.6.2.5 Adjusting the depth of the calf plate

The depth of the calf plate can be adjusted via the holding plate. The holding plate hole combinations allow 5 different depth settings.



---

**Pre-requisites:**

- 1x 10 mm open-ended spanner
- 

- Use the open-ended wrench to loosen the nut (1) and remove.
- Adjust to the desired depth. Please observe that the round holes are intended for the calf plate retaining screw and the oblong holes for the aglet without thread.
- Screw the nut back on and tighten.



### 8.6.2.6 Adjusting the height of the calf plate



---

**Pre-requisites:**

- 1x 4 mm Allen key
- 
- Use the Allen key to loosen the screws (1).
  - Adjust to the desired position.
  - Re-tighten the screws.



### 8.6.2.7 Unlocking and swivelling the calf plate backward when alighting

- Press the calf plate straight down.



- Unlock the legrest and swivel outward. The calf plate swivels backward on its own.



- Lift leg over the heel strap and place on the ground.



### 8.6.2.8 Adjusting the angle adjustable foot plate



---

**Pre-requisites:**

- 1x 5 mm Allen key
- 
- Use the Allen key to loosen both set screws on the foot plate.
  - Adjust to the desired angle.
  - Re-tighten the screws.



### 8.6.2.9 Adjusting the angle and depth adjustable foot plate



---

**Pre-requisites:**

- 1x 5 mm Allen key
- 
- Use the Allen key to loosen the set screw on the foot plate (1).
  - Adjust the foot plate to the desired angle or depth.
  - Re-tighten the screw.



## **9 Electrical system**

### **9.1 Electronics protection system**

The vehicle's electronics are equipped with an overload-protection system.

If the motors are put under considerable strain for a longer period of time (for example, when driving up a steep hill) and especially when the ambient temperature is high, then the electronic system could overheat. In this case the vehicle's power is reduced gradually until it finally comes to a halt. The Status Display shows a corresponding error code (see chapter "Fehler! Verweisquelle konnte nicht gefunden werden." on page Fehler! Textmarke nicht definiert.). By switching the power supply off and back on again, the error code is cancelled and the electronics are switched back on. It will take approximately five minutes until the electronics have cooled down enough for the motors to restore full power again.

When the motors are stalled by an insurmountable obstacle, such as a high kerb, and the vehicle driver allows the motors to strain against this hindrance for more than 20 seconds without moving, then the electronics will automatically switch off to prevent the motors from being damaged. The Status Display shows a corresponding error code (see chapter "Fehler! Verweisquelle konnte nicht gefunden werden." on page Fehler! Textmarke nicht definiert.). By switching off and back on again, the error code is cancelled and the electronics are switched back on.

## 9.1.1 The main fuse



---

### NOTE

A defective main fuse may be replaced only after checking the entire electric system. An Invacare® specialised dealer must perform the replacement. You can find information on the fuse type in chapter "**Technical specifications**" starting on page **91**.

---

The entire electric system of the wheelchair is protected by the main fuse against overloading.

The main fuse is to be found underneath the battery cover (1).



## **9.2 Batteries**

### **9.2.1 What you need to know about batteries**

Power is supplied by two 12 V batteries. The batteries are maintenance-free and only need regular charging.

New batteries should always be fully charged once before their first use. New batteries will be at their full capacity after having run through approx. 10 - 20 charging cycles. How fast the batteries discharge depends on many circumstances, such as ambient temperature, condition of the surface of the road, tyre pressure, weight of the driver, way of driving and utilisation of lighting.





---

## NOTE

The batteries supplied with your electric vehicle are not hazardous goods. This classification is based on the German *GGVS Hazardous Goods Road Transport Ordinances*, and the *IATA/DGR Hazardous Goods Rail Transport / Air Transport Ordinances*. Batteries may be transported without restrictions, whether by road, rail or by air. Individual transport companies have, however, guidelines which can possibly restrict or forbid certain transport procedures. Please ask the transport company regarding each individual case.

Pay attention to the Battery Charge Indicator! Make sure to charge the batteries when the Battery Charge Indicator shows that battery charge is low. We recommend charging the batteries after each trip, as well as each night over night. Depending on the level of discharge, it can take up to 12 hours until the batteries are fully charged again.

Protect your charger from sources of heat such as heaters and direct sunlight. If the battery charger overheats, charging current will be reduced and the charging process delayed.

To avoid damaging the batteries, never allow them to be fully discharged. Do not drive on heavily discharged batteries if it is not absolutely necessary, as this will strain the batteries unduly and shorten their life expectancy.

In case your vehicle is not used for a longer period of time, then the batteries must be charged at least once a month to maintain a full charge. Alternatively, the vehicle can stay connected to the charger. The batteries cannot be overcharged with the specified charger.

Please use only charging devices in Class 2. This class of chargers may be left unattended during charging. All charging devices which are supplied by Invacare® comply with these requirements.

---

## 9.2.2 Charging the batteries

- Make sure you read and understand the battery charger's User's Manual, if supplied, as well as the safety notes on the front and rear panels of the charger!
- 



**WARNING: Danger of explosion and destruction of batteries if the wrong battery charger is used!**



- *Only ever use the battery charger supplied with your vehicle, or a charger that has been approved by Invacare®.*

**Danger of electric shock and damage to the battery charger if it is allowed to get wet!**

- *Protect the battery charger from water.*
- *Always charge in a dry environment.*

**Danger of short circuit and electric shock if the battery charger has been damaged!**

- *Do not use the battery charger if it has been dropped or damaged.*

**Danger of fire and electric shock if a damaged extension cable is used!**

- *Only ever use an extension cable if it is absolutely necessary. In case you must use one, make sure it is in good condition.*
-

## Charging the batteries

- Switch off the wheelchair at the Joystick Box.
- Connect the battery charger to the Joystick Box - the charging socket is located on the bottom of the Joystick Box (1).
- Connect battery charger to the mains outlet and switch on if necessary.
- After charging is complete, first disconnect the battery charger from the mains supply, then disconnect from the Joystick Box.



### 9.2.3 Removing and fitting batteries

---



**WARNING:**

**Danger of injury if the batteries are not handled correctly during assembly and maintenance work!**

- *New batteries should be installed by authorised technicians!*
- *Observe the warnings on the batteries!*
- *Take into account the heavy weight of the batteries!*
- *Only ever use the battery type defined in the technical specifications (see "**Technical specifications**" on page 91)!*

**Danger of fire and burns if battery terminals are short-circuited!**

- *DO NOT short-circuit battery terminals with a tool!*
- 



**WARNING:**

**Corrosion and burns from acid leakage if batteries are damaged!**

- *Remove clothes that have been soiled by acid immediately.*

**After contact with skin:**

- *Immediately wash affected area with lots of water.*

**After contact with eyes:**

- *Immediately rinse eyes under running water for several minutes; consult a physician.*
-

### 9.2.3.1 Removing the batteries



---

**CAUTION: Risk of fire and burns if battery poles are bridged!**

- *When replacing the batteries the battery poles MUST NOT come into contact with metal parts of the wheelchair causing bridging.*
  - *Be sure to replace the battery pole caps after the batteries have been replaced.*
- 

**Pre-requisites:**

- 11 mm open-ended spanner
- 

- Remove the battery cover.



- Remove the plastic clips (1) pull the electronic device support backwards and upwards.



- Pull the battery pole caps (1) upward and push back in order to reach the battery poles.
- Use the open-ended spanner to loosen the battery pole clamp (2).
- Flip the electronic device support upwards (if necessary, release the connecting plugs).
- Pull out the batteries.



### 9.2.3.2 How to handle damaged batteries correctly

---



#### **WARNING:**

#### **Corrosion and burns from acid leakage if batteries are damaged!**

- *Remove clothes that have been soiled by acid immediately.*

#### **After contact with skin:**

- *Immediately wash affected area with lots of water.*

#### **After contact with eyes:**

- *Immediately rinse eyes under running water for several minutes; consult a physician.*
- 

- Always wear safety goggles and appropriate safety clothing when handling damaged batteries.
- Place damaged batteries in an acid-resistant receptacle immediately after removing them.
- Only ever transport damaged batteries in an appropriate acid-resistant receptacle.
- Wash all objects that have come into contact with acid with lots of water.

#### **Disposing of dead or damaged batteries correctly**

Dead or damaged batteries can be given back to your dealer or directly to Invacare®.

## 10 Care and maintenance

---



### **NOTE:**

Have your vehicle checked at least twice a year by an authorised Invacare® dealer in order to maintain its driving safety and roadworthiness.

---

### **Cleaning the vehicle**

When cleaning the vehicle, pay attention to the following points:

- Only use a damp cloth and gentle detergent.
- Do not use any abrasive or scouring liquids.
- Do not subject the electronic components to any direct contact with water.
- Do not use high-pressure cleaning devices.

### **Disinfection**

Spray or wipe disinfection using a tested and recognised product is permitted. A list of the current permitted disinfectants is available from the Robert Koch Institute at <http://www.rki.de>.



## 10.1 Safety checks that should be performed by the user

<b>Explanation of the symbols:</b>	
✓	During normal use, as well as during use as a piece of sports equipment
!	Especially during use as a piece of sports equipment

<b>Maintenance Jobs</b>	When Delivered	Before each use as sports equipment	Weekly	Monthly
<b>Seat and backrest padding:</b>				
- Check for perfect condition.				✓
<b>Side part and armrest:</b>				
- Are all fastening elements correctly tightened?	✓	!	✓	
- Can armrests / side parts be removed and installed without too much physical effort?			✓	
- Are armrests secured in their positions?		!	✓	
<b>Legrests:</b>				
- Do legrests lock into place without any problem (only applies to detachable legrests)?		!	!	✓
- Do the different adjustment functions work without any problem?			!	✓
<b>Tyres:</b>				
- Have tyres checked for specified air pressure (2,5 bar).	✓	!	!	✓

Maintenance Jobs	When Delivered	Before each use as sports equipment	Weekly	Monthly
<b>Front wheel forks / Front wheels</b>				
- Front wheels must be running smoothly.		!	✓	
- Check fork bearing for firm seat (torque 15 Nm +/- 1,5 Nm).			!	✓
<b>Rear wheels:</b>				
- Test wheel for firm seat on the axle drive shaft.			!	✓
- Rear wheels must turn without wobbling		!	!	✓
<b>Electronics / Electrical System:</b>				
- Check all plug connections for condition and firm seat.			!	✓
- Fully charge the batteries before daily use.	Before every trip			
- Are all holders, screws firmly fixed, tight and safe?			!	✓
- Are all electric bulbs of the lighting system (if applicable) in working order?	Before every trip			
<b>Cleaning:</b>				
- Clean all parts carefully.	When necessary			

**Once a year you should have your wheelchair inspected and serviced by your authorised dealer, if it is used as a piece of sport equipment then it should be inspected twice a year. If the wheelchair is serviced at regular intervals, damaged or worn parts can be located and replaced in time, thus preserving it in good working order. A complete checklist of necessary maintenance work can be found in the Service Manual, which can be obtained from Invacare®.**

# 11 Repair Instructions

The following are instructions on repairs that can be performed by the user. For the specifications of spare parts please see "**Technical specifications**" on page 91, or consult the Service Manual, available from Invacare® (in this connection please see the addresses and phone numbers in section "**How can you get in touch with Invacare®?**" on page 2). In case you require assistance, please contact your Invacare® Dealer.

## 11.1 Repairing a flat tyre



---

**WARNING: Danger of damage or injury if the vehicle is accidentally set into motion during repairs!**

- *Switch the power off (ON/OFF Button)!*
  - *Engage the motors!*
  - *Secure the vehicle against rolling away by placing wedges under the wheels!*
-

### 11.1.1 Repairing a flat tyre at the back (tyre type 3.00-8")

---



**Injury hazard! If the wheel has been insufficiently secured during assembly, it can become loosened during driving!**

- *When refitting the drive wheels, tighten the Torx screw that secures the wheel to the hub to a torque of 30 Nm!*
  - *Secure all screws using a suitable threadlock (e.g. Loctite 243)!*
- 



#### **Requirements:**

- Torque wrench with ...
  - Allen bit 5 mm
  - Torx bit T40
  - Repair kit for tyre repair **or** a new inner tube.
  - Talcum powder
  - Threadlock Loctite (e.g. Loctite 243)
-

## Removing the wheel

- Jack the vehicle up and place a block of wood underneath it to prop it up.
- Remove the countersunk screw (1) using the Torx bit.
- Remove the wheel from the axle.



**EXPLOSION HAZARD! The wheel will explode if the air pressure is not released from the tyre before disassembling the wheel rim!**

- *Always make sure to completely release the air pressure by pressing the pin in the centre of the valve!*

## Repairing the flat tyre

- Remove the valve cap.
- Let the air out of the tyre completely by pressing the pin in the centre of the valve in.
- Remove the 5 cylinder head screws (back of the wheel, 2).
- Remove the rim halves from the tyre.
- Remove the inner tube from the tyre.
- Repair the inner tube and re-fit, or replace it with a new one.

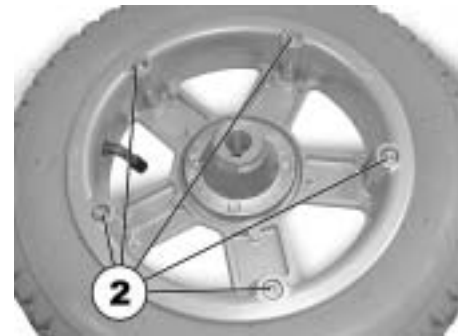



---

**NOTE**

In case the old inner tube is to be repaired and used again, and it happens to get wet during repair, then it is easier to re-fit it if you powder it lightly with talcum powder.

---



---

**NOTE**

Re-assembly is done in reverse order. Make sure that the wheel is put back on the same side it was on, and that it runs in the same direction it did before it was removed.

---

- Re-fit the rim halves back into the tyre.
- Pump up the tyre a little.
- Insert the cylinder head screws in the rim and tighten to 10 Nm. Make sure the inner tube does not get pinched between the rims halves!
- Check to make sure that the tyre is squarely in place on the rim.
- Pump up the tyre to the recommended tyre pressure.
- Check to make sure that the tyre is still squarely and snugly in place on the rim.
- Screw the valve cap back on.
- Refit the wheel.
- Refit the Torx screw using threadlock and tighten to 30 Nm.

# 12 Transport

## 12.1 Transferring the wheelchair to a vehicle

---



**WARNING:** Danger of tipping over, if the wheelchair is transferred to a vehicle using a ramp that exceeds the maximum safe slope, or if the backrest is not in an upright position during transfer!

- *If the wheelchair has to be transferred to a vehicle using a ramp that exceeds the maximum safe slope (see chapter "Technical specifications" starting on page 91), then a winch must be used. An attendant can then safely oversee and assist the transfer process.*
  - *If no winch is installed, then the wheelchair must not be transferred to a vehicle using a ramp that exceeds the maximum safe slope.*
  - *Alternatively, a tail lift installed in the vehicle may be used.*
  - *Only ever transfer the wheelchair to a vehicle with the backrest in an upright position. Ensure that the total weight of the mobility aid including the user does not exceed the highest permissible weight for the platform lift.*
  - *Only ever run the wheelchair with the seat back in the upright position, seat lifter lowered and the seat tilting in the upright position into the transport vehicle (please refer to chapter "Driving up and down gradients" on page 31).*
- 

- Drive or push your wheelchair into the transport vehicle using a suitable ramp.

## 12.2 Securing the wheelchair for transport without passengers



---

### CAUTION: Injury hazard!

- *If you are unable to fasten your electric wheelchair securely in a transport vehicle, we recommend that you do not transport it!*
- 

- Before transporting your wheelchair, make sure the motors are engaged and that the Joystick Box is switched off.
- We urgently recommend securing the wheelchair to the floor of the transporting vehicle.

The wheelchair can be secured with straps at the following points:

Front



Rear bumper



Rear wheel



Only the left-hand side in each case is visible in the picture.



## 13 Refurbishment

The product is suitable for refurbishment. Actions to be carried out:

- Cleaning and disinfection. Please see chapter "Care and maintenance" on page **80**.
- Inspection according to service plan. Please consult service instructions, available from Invacare®.
- Adaptation to the user. Please see chapter "Adjusting the wheelchair to the user's seating posture" on page **34**.

## 14 Disposal

- The equipment wrapping is potentially recyclable.
- The metal parts are used for scrap metal recycling.
- The plastic parts are used for plastic recycling.
- Electric components and printed circuit boards are disposed of as electronic scrap.
- Exhausted or damaged batteries can be returned to your medical equipment supplier or Invacare®.
- Disposal must be carried out in accordance with the respective national legal provisions.
- Ask your city or district council for details of the local waste management companies.

# 15 Technical specifications

<b>Permissible operating and storage conditions</b>	
Temperature range for operation according to ISO 7176-9:	<ul style="list-style-type: none"> <li>• -25° ... +50 °C</li> </ul>
Temperature range for storage according to ISO 7176-9:	<ul style="list-style-type: none"> <li>• -40° ... +65 °C</li> </ul>

<b>Electric System</b>	
Motors	<ul style="list-style-type: none"> <li>• 2 x 350 W</li> </ul>
Batteries	<ul style="list-style-type: none"> <li>• 2 x 12 V/70 Ah (C20) leakproof/gel</li> </ul>
Main fuse	<ul style="list-style-type: none"> <li>• 50 A</li> </ul>

<b>Battery Charger</b>	
Output current	8 A ± 8 %
Output voltage	24 V nominal (12 cells)
Input voltage	200 – 250 V nominal
Operating temperature (surroundings)	-5° ... +40 °C
Storage temperature	-20° ... +50 °C

<b>Drive wheel tyres</b>	
Tyre type	<ul style="list-style-type: none"> <li>• Trelleborg 8x3.00 pneumatic</li> </ul>
Tyre pressure	<ul style="list-style-type: none"> <li>• 2.8 bar</li> </ul>

<b>Castor wheel tyres</b>	
Tyre type	<ul style="list-style-type: none"> <li>• 200x50 puncture-proof</li> </ul>

<b>Driving features</b>	
Speed	• 10 km/h
Min. braking distance	• 2100 mm
Max. safe slope *****	• 10° (18 %) according to manufacturer's specifications with 120 kg payload, 4° seat angle, 20° backrest angle
Max. climbable obstacle height	• 60 mm
Turning diameter	• 830 mm
Range according to ISO 7176-4:2008 ***	• approximately 45 km

<b>Dimensions</b>	
Total height	• 950 mm
Total width	• 630 mm
Overall length (incl. std. footrests)	• 1100 mm
Total length (excl. legrests)	• 880 mm
Seat height ****	• 455 - 530 mm
Seat width (adjustable range of the armrests in brackets)	• 430 mm (440 - 490 mm**)
Seat depth	• 410/460/510 mm
Height of backrest	• 480/540 mm
Seat cushion thickness	• 50 mm
Backrest angle	• -10°, 0°, +7.5°, +15°, +22.5°, +30°
Height of armrest	• 290 - 360 mm
Footrest length	• 330 / 340 / 350 / 360 / 380 / 390 / 420 mm
Seat tilt, manual adjustment	• up to 22°

<b>Weight *****</b>	
Kerb weight	• 115 kg

## Loading

Max. load

- 120 kg

\* Approximately.

\*\* Width adjustable for side panel adjustment

\*\*\* Note: The drive range of an electric wheelchair is strongly influenced by external factors, such as the charging state of the batteries, surrounding temperature, local topography, road surface characteristics, tyre pressure, weight of user, drive style and use of batteries for lighting, servos etc.

\*\*\*\* Measured without seat cushion

\*\*\*\*\* The actual kerb weight depends on the fittings your mobility aid has been supplied with. Every Invacare® mobility aid is weighed when leaving the works. Please refer to the nameplate for the kerb weight (including batteries) measured.

\*\*\*\*\* Static stability according to ISO 7176-1 = 9° (15,8 %)  
Dynamic stability according to ISO 7176-2 = 6° (10,5 %)

# 16 Inspections Performed

It is confirmed by stamp and signature that all jobs listed in the inspection schedule of the Service and Repair Instructions have been properly performed. The list of the inspection jobs to be performed can be found in the Service Manual which is available through Invacare®.

<u>Delivery Inspection</u>	<u>1<sup>st</sup> Annual Inspection</u>
Stamp of authorised Dealer / Date / Signature	Stamp of authorised Dealer / Date / Signature
<u>2<sup>nd</sup> Annual Inspection</u>	<u>3<sup>rd</sup> Annual Inspection</u>
Stamp of authorised Dealer / Date / Signature	Stamp of authorised Dealer / Date / Signature
<u>4<sup>th</sup> Annual Inspection</u>	<u>5<sup>th</sup> Annual Inspection</u>
Stamp of authorised Dealer / Date / Signature	Stamp of authorised Dealer / Date / Signature



Order No. of this Manual: 1496160.DOC  
Release Date: 2011-01-20

**English**