

# MICKEY BEVERAGE PARTS and OPTIONS



**MICKEY TRUCK BODIES INC**

1305 Trinity Ave, P.O. Box 2044, High Point, NC 27261

Tel: 800-334-9061

[www.mickeybody.com](http://www.mickeybody.com)

DESIGNED TO WORK.  
BUILT TO LAST.

DESIGNED TO WORK.  
BUILT TO LAST.

DESIGNED TO WORK.  
BUILT TO LAST.

DESIGNED TO WORK.  
BUILT TO LAST.

DESIGNED TO WORK.  
BUILT TO LAST.

DESIGNED TO WORK.  
BUILT TO LAST.

DESIGNED TO WORK.  
BUILT TO LAST.

DESIGNED TO WORK.  
BUILT TO LAST.

DESIGNED TO WORK.  
BUILT TO LAST.

DESIGNED TO WORK.  
BUILT TO LAST.

DESIGNED TO WORK.  
BUILT TO LAST.

DESIGNED TO WORK.  
BUILT TO LAST.

DESIGNED TO WORK.  
BUILT TO LAST.

DESIGNED TO WORK.  
BUILT TO LAST.

DESIGNED TO WORK.  
BUILT TO LAST.

DESIGNED TO WORK.  
BUILT TO LAST.

DESIGNED TO WORK.  
BUILT TO LAST.

DESIGNED TO WORK.  
BUILT TO LAST.

DESIGNED TO WORK.  
BUILT TO LAST.

DESIGNED TO WORK.  
BUILT TO LAST.

DESIGNED TO WORK.  
BUILT TO LAST.

DESIGNED TO WORK.  
BUILT TO LAST.

DESIGNED TO WORK.  
BUILT TO LAST.

DESIGNED TO WORK.  
BUILT TO LAST.

DESIGNED TO WORK.  
BUILT TO LAST.

DESIGNED TO WORK.  
BUILT TO LAST.

DESIGNED TO WORK.  
BUILT TO LAST.

DESIGNED TO WORK.  
BUILT TO LAST.

## Table of Contents

	<b>Page (s)</b>
<b>Section 1</b>	
Mickey Corporate Overview .....	3
Regional Reconditioning and Service Centers .....	4
<b>Section 2</b>	
Beverage Body and Trailer Illustrations .....	5
<b>Section 3</b>	
Parts Descriptions and Illustrations .....	6 - 11
<b>Section 4</b>	
Caution Signs & Information Tags .....	12 - 13



## Section 1 - Mickey Corporate Overview

*Thank you* for your confidence in our company, our products and our people.

Mickey Truck Bodies Inc is a family-owned and operated company, and has been since it was founded by W.F. Mickey in 1904. The company is still owned and managed by the Mickey family.

Mickey designs and builds a wide line of bodies and trailers for several industries, including beverage, furniture, emergency services, home improvement, snack foods and battery distribution. All told, the company builds thousands of units a year for the likes of Interstate Batteries, Coca-Cola, Pepsi-Cola, Nabisco, Frito Lay, Nestle', Anheuser-Busch, Miller Beer and The Compass Group USA/Canteen, and its products are now available in over 30 countries around the world.

One of the main factors behind Mickey's tremendous growth over the past several years has been its unwavering commitment to after-sales customer service and support. The company offers a large inventory of stock parts that are shipped the same day on all orders received by 2 P.M., and all fabricated parts are shipped within one to three working days.

Any part that is received damaged, or is not the exact part ordered, will be replaced and shipped the day of notification at no charge, with no questions asked.

A "Parts and Service Manual" detailing Mickey's complete line of parts is available upon request. If you need something that we do not carry as stock, we will make every attempt to get it for you.

Over the past several years, Mickey has also implemented an aggressive expansion plan for its regional reconditioning division. Currently, the company owns and operates four facilities throughout the country, capable of repairing, reconditioning or servicing any body or trailer.

When you bought your body or trailer from Mickey, it was just the beginning of what we trust will be a very long and mutually prosperous relationship. To help establish and develop that relationship, we intend to stand behind the product we sold you. That is part of Mickey's commitment to excellence.

*This Parts Manual was developed as a user-friendly guideline for identifying and ordering the parts or options for your Mickey Van Bodies. We take great pride in offering our customers custom-designed equipment, features and options. If you need any help beyond the information provided in this manual, please call us at our toll-free number 800-334-9061 and we'll be happy to help you in any way that we can.*

Again, thank you for your business and your confidence. Please drive safely.

Dean Sink  
Mickey President

### Convenient Reconditioning and Service Centers

Mickey Truck Bodies Inc **owns and operates** a national network of Reconditioning and Service Centers designed to handle all major and minor reconditioning and repair work, including paint and graphics applications.



### No Surprises

We handle every reconditioning and repair job separately and uniquely according to the specific needs of the customer. All labor and parts costs are outlined in Work Estimates that must be approved in advance by the customer. If other needs or recommendations occur during the reconditioning or repair process, the customer will be notified in advance, in writing, and must approve all extended work and additional costs.

### Used Equipment

Mickey stocks a wide assortment of road-ready bodies and trailers that have been completely reconditioned. We also pay competitive rates for quality used vehicles.

Visit our web site at [www.mickeyusedtrucks.com](http://www.mickeyusedtrucks.com) While we don't keep all of our used equipment inventory on this site we do maintain representative samples. In many cases this site may list just one of many similar units we have in stock. We suggest you browse our on-line inventory and then give one of our sales representatives a call at 1-800-334-9061. Ask for Used Truck Sales or dial extension 3257. Our inventory listings are split by class to allow you to focus on your needs and shorten your equipment search.

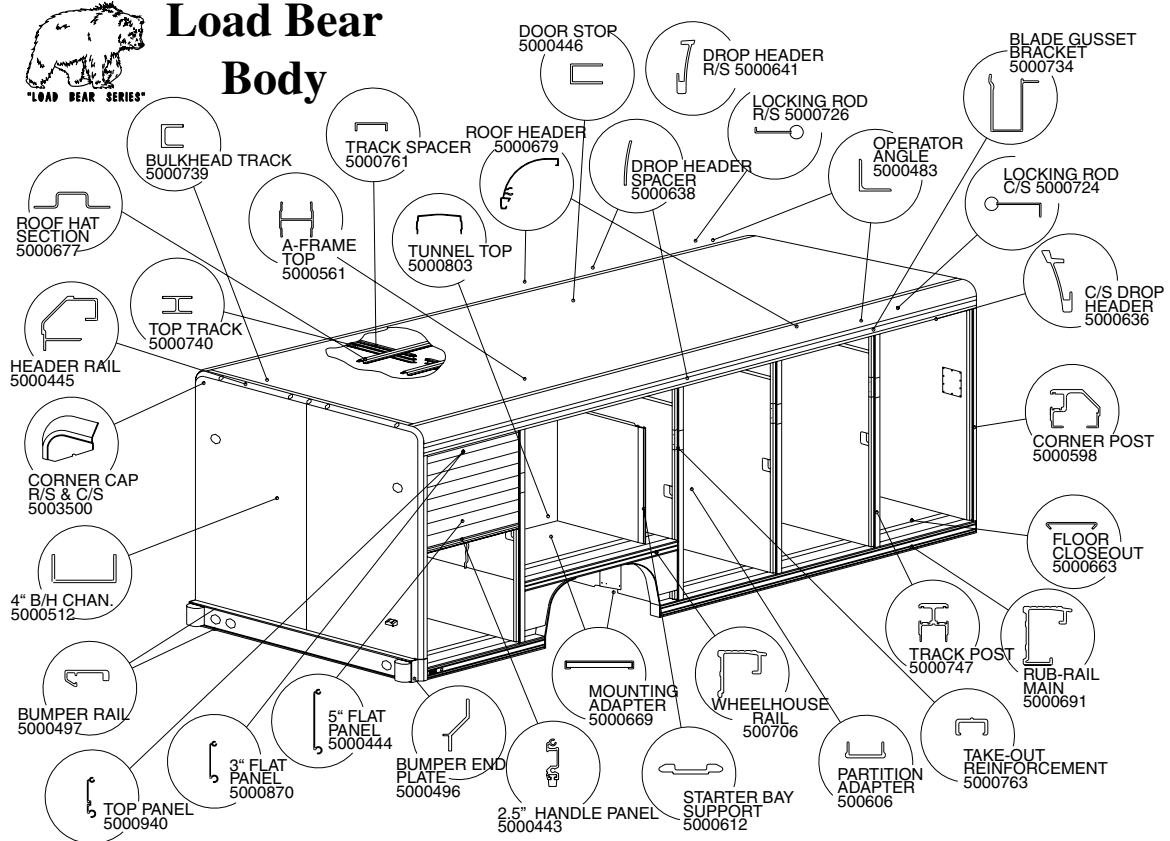

## Load Bear Trailer

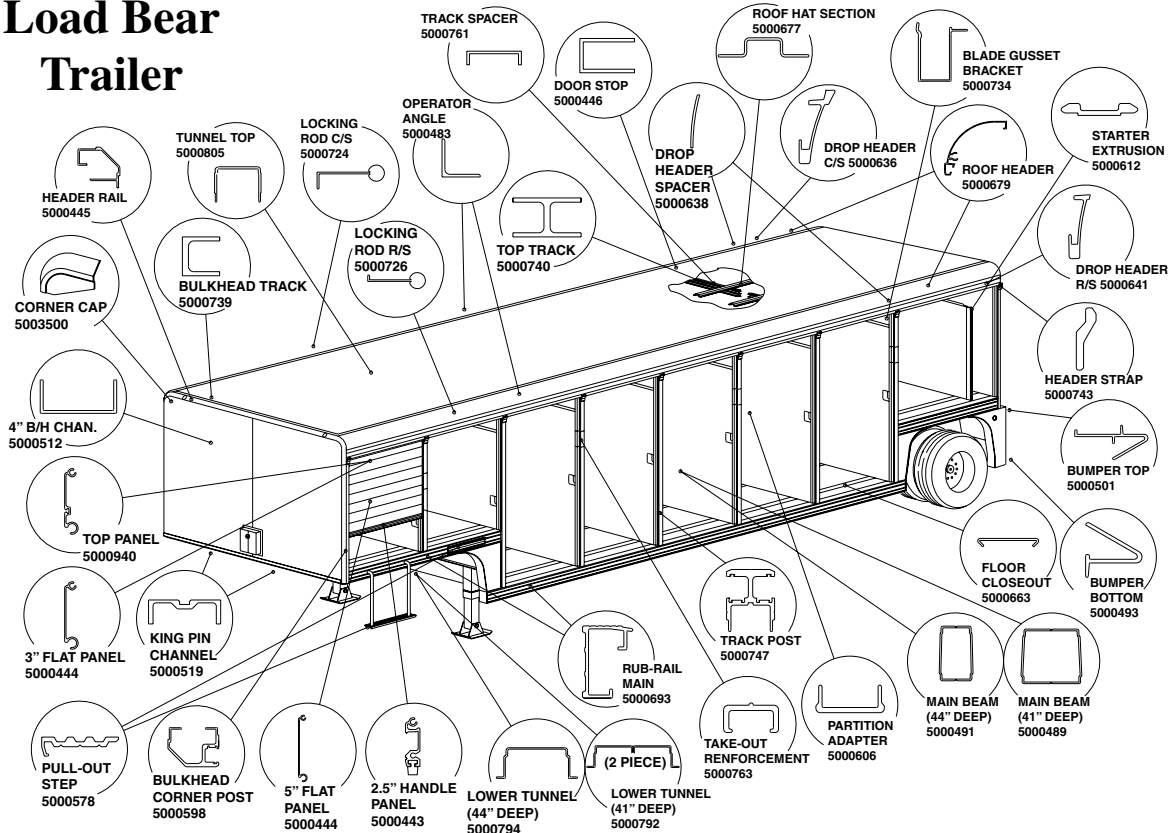

Part Description	Item Number	Part Description	Item Number
Door Operators (counter balance)	5002450	Door Straps 33"	6006044

Operator 37"  
Operator 30"

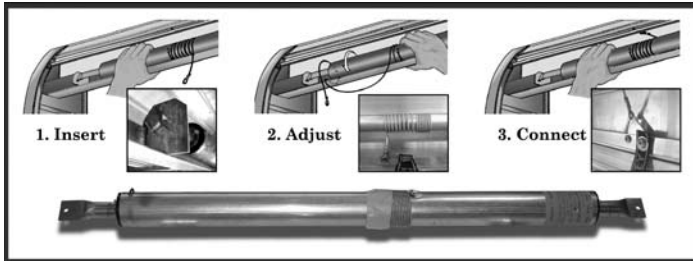

#3 Door Roller  
Hackney Door Roller  
Centennial Door Roller

6900020



Door Cable

6800230



Pad Locking Door Handle

5003920

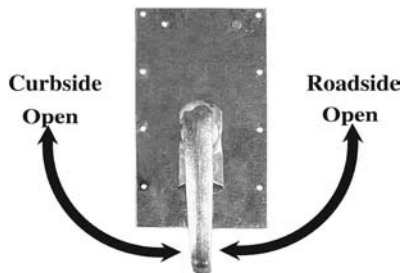

Pull-Out Step

5006273



Key Locking Door Handle

5003910

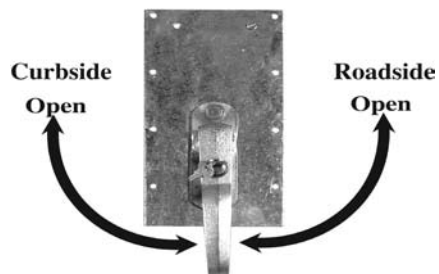

Wheel-House Step Bar

5002680





### Section 3 - Parts Descriptions and Illustrations

Part Description	Item Number	Part Description	Item Number
Mud Flap (24" x 12")	6711280	Hand Truck Rack Lock	6101793
		Hand Truck Rack Lock Block	6004745

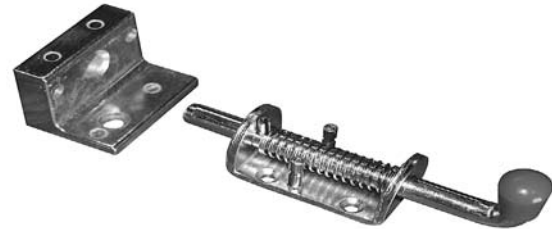

Mud Flap (24" x 12")

Hand Truck Swing Arm and Lock  
(Note: Lock Block and Latch not included)



Hand Truck Rack (Standard)

4916087

Safe 26"

4950137





Front Hand Truck Rack (Standard)

4916083

Safe 36"

4953202

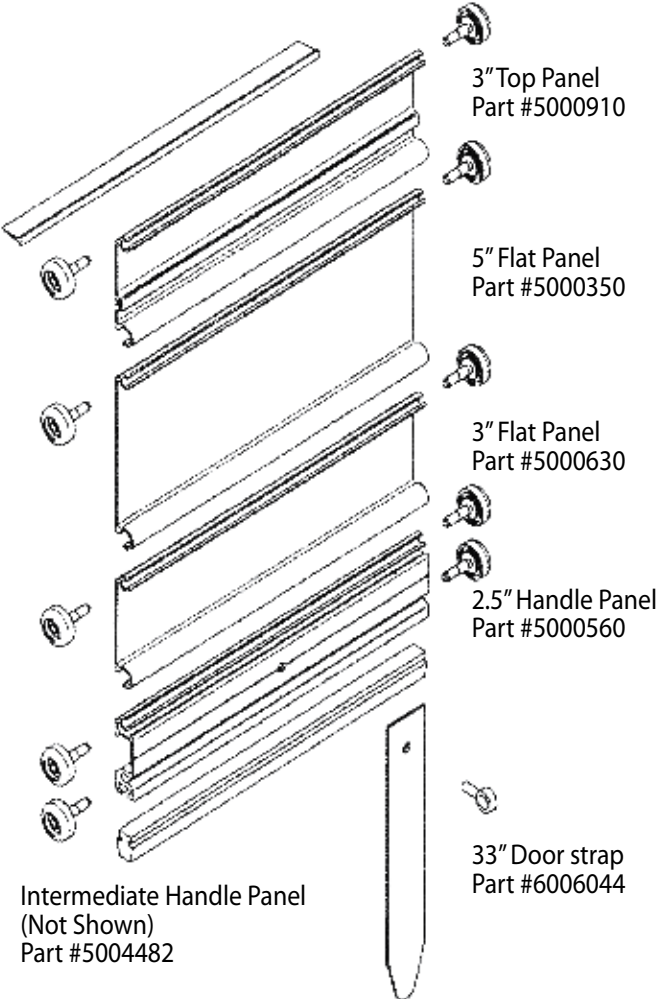

Part Description	Item Number	Part Description	Item Number
Cable Retainer	4951206	3" Top Door Panel x 53"	5000910
	6100617	3" Flat Door Panel x 53"	5000630
		Track Liner (Current)	Intermediate Door Handle Panel 53"
	6000098	5" Flat Door Panel x 53"	5000350
		Safety Hand Grips	2 1/2" Handle Panel x 53"
	6000098		
		3" Top Panel Part #5000910	
		5" Flat Panel Part #5000350	
		3" Flat Panel Part #5000630	
		2.5" Handle Panel Part #5000560	
		33" Door strap Part #6006044	
Intermediate Handle Panel (Not Shown) Part #5004482			





## Section 3 - Parts Descriptions and Illustrations

Part Description	Item Number	Part Description	Item Number
16" Rear Bumper (Aluminum)	4951222	12" Rear Bumper (Aluminum)	4951222

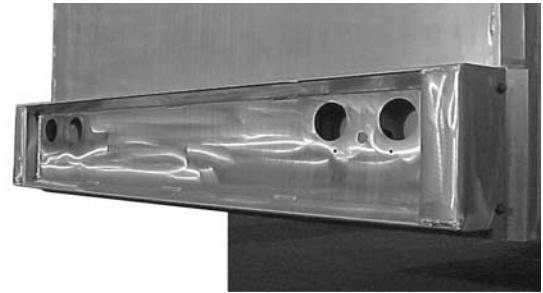
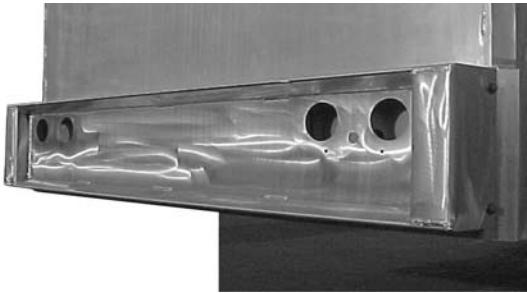

9" Rear Bumper (Aluminum)	4950080
---------------------------	---------

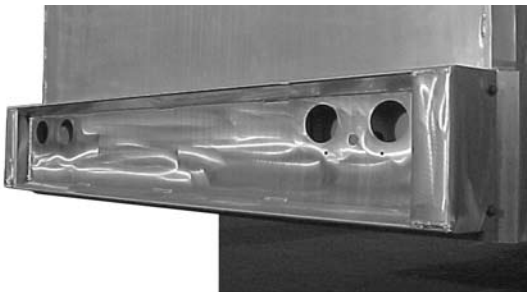

5" Rub Rail Aluminum
----------------------



Touch-Up Spray Paint	4951362
----------------------	---------



6" Rub Rail Aluminum
----------------------



Crank Handle	6800470
--------------	---------



**Part Description**  
Shelf, Removable 52" Bay

**Item Number**  
4954155



**Part Description**  
Bolt On Wheelhouse Step Pin

**Item Number**  
5002710



Bumper, Heavy Duty 4900/4700



Eyebolt & Nut Assembly

500440



25" Vertical Dock Bumper

6911260



Lynch Ring

5002720



12" Vertical Dock Bumper



Lock Cylinder #1250

6000797



### Lock Cylinder Replacement

#### TO REMOVE CYLINDER

1. Push in lock cylinder until  $3/16$ " of cylinder is showing outside locking handle.
2. While holding the cylinder at this  $3/16$ " position, turn the key hard to the left (counter-clockwise). Cylinder should snap allowing spring to push cylinder out into hand.

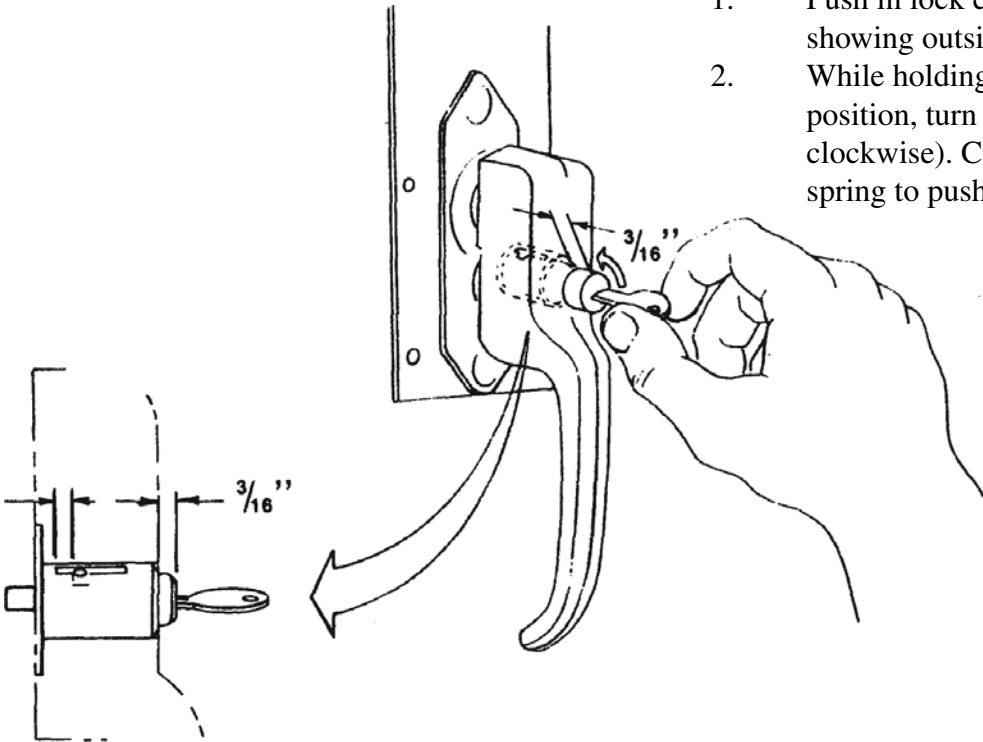

#### TO INSTALL CYLINDER

1. Insure that spring is in position inside cylinder barrel.
2. With cylinder turned to the right extreme (clockwise), align lobe on cylinder with smaller slot in cylinder barrel.
3. Push cylinder into barrel until  $3/16$ " cylinder shows outside barrel.
4. While holding this  $3/16$ " position, turn key hard to the right (clockwise). Cylinder should snap to the right, locking into position.

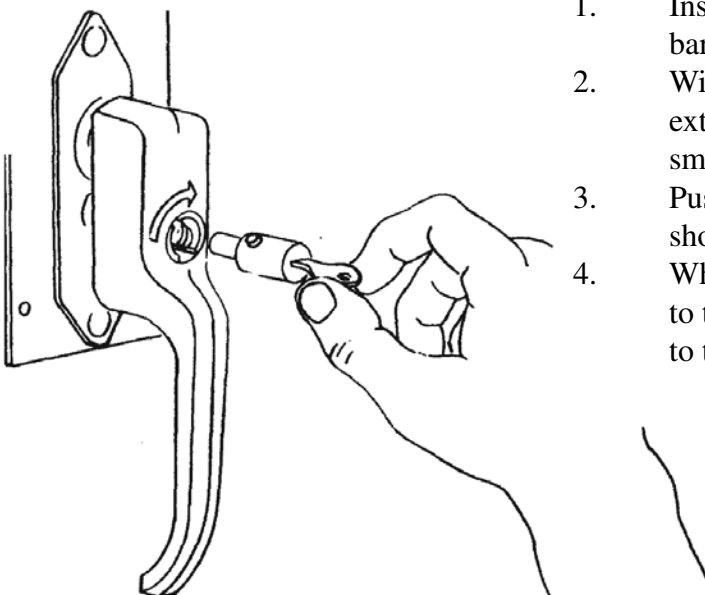



## Section 4 - Caution Signs & Information Tags

Your Mickey Body is equipped with Caution Signs and Unit Designations in all appropriate places. Please become familiar with these tags. (If these tags are removed or become damaged, Mickey Truck Bodies will replace at no charge.)

	MFG. BY <b>MICKEY TRUCK BODIES INC</b> HIGH POINT, NC (336) 882-6806
DATE OF MFG.	_____
MODEL	SERIAL
THIS PRODUCT MAY BE COVERED BY ONE OR MORE OF THE FOLLOWING PATENTS #6,022,067	

Location: Front bulkhead under the locking handle on the driver's side.

MANUFACTURED BY: <b>MICKEY TRUCK BODIES INC.</b> HIGH POINT, NORTH CAROLINA 27261 DATE OF MFR: MO. _____ YR. _____ INCOMPLETE VEHICLE MANUFACTURED BY : _____ DATE OF INC. VEH. MFR: MO. _____ YR. _____ GVWR: _____ KG ( _____ LB) GAWR-FRONT: _____ KG ( _____ LB) GAWR-REAR: _____ KG ( _____ LB) CONFORMITY OF THE CHASSIS-CAB TO U.S.A. FEDERAL MOTOR VEHICLE SAFETY STANDARDS, WHICH HAVE BEEN PREVIOUSLY FULLY CERTIFIED BY THE INCOMPLETE VEHICLE MANUFACTURER OR BY THE INTERMEDIATE VEHICLE MANUFACTURER, HAS NOT BEEN AFFECTED BY THE ANAL-STAGE MANUFACTURE. THE VEHICLE HAS BEEN COMPLETED IN ACCORDANCE WITH PRIOR MANUFACTURER'S INSTRUCTIONS, WHERE APPLICABLE. THIS VEHICLE CONFORMS TO ALL OTHER APPLICABLE U.S.A. FEDERAL MOTOR VEHICLE STANDARDS IN EFFECT IN: MO. _____ YR. _____ VEHICLE IDENTIFICATION NUMBER: _____ _VEHICLE TYPE: _____	

<b>SUITABLE TIRE-RIM CHOICE</b>	
FRONT:	_____ TIRES, _____ RIMS, @ _____ KPA, ( _____ PSI) COLD _____
INTERMEDIATE (1):	_____ TIRES, _____ RIMS, @ _____ KPA, ( _____ PSI) COLD _____
INTERMEDIATE (2):	_____ TIRES, _____ RIMS, @ _____ KPA, ( _____ PSI) COLD _____
REAR:	_____ TIRES, _____ RIMS, @ _____ KPA, ( _____ PSI) COLD _____

Location: Inside cab door jamb drivers side

	MFG. BY: <b>MICKEY TRUCK BODIES INC</b> HIGH POINT, NC (336) 882-6806
DATE OF MANUFACTURE	MODEL
SERIAL	GVWR: _____ KG ( _____ LBS) BASED ON UNIFORM WEIGHT DISTRIBUTION
GAWR: _____ AXLE(S) AT 8636 KG (19040 LBS) WITH 10.00 - 20 (F) TIRES, AND 20 X 7.5 RIMS AT 520 KPA (75 PSI) COLD DUAL PER AXLE	
THIS VEHICLE CONFORMS TO ALL APPLICABLE FEDERAL MOTOR VEHICLE SAFETY STANDARDS IN EFFECT ON THE DATE OF MANUFACTURE SHOWN ABOVE	
VIN	TYPE: ROUTE TRAILER
THIS PRODUCT MAY BE COVERED BY ONE OR MORE OF THE FOLLOWING PATENTS #6,022,067	

Location: Front bulkhead under the locking handle on the driver's side.

<b>CAUTION</b>
<b>CLOSE DOORS BEFORE LOCKING.</b>
<b>DOORS MUST BE LOCKED WHEN</b>
<b>VEHICLE IS IN MOTION.</b>

Location: Front bulkhead (and rear bulkhead on some units) under the locking handle on both sides.

**WARNING**  
 THIS VEHICLE IS EQUIPPED WITH A BACK-UP ALARM. ALARM MUST SOUND WHEN BACKING. OPERATOR MUST MAKE CERTAIN ALARM IS WORKING BEFORE OPERATING THIS VEHICLE.

Location: Inside cab, on dash

**ATTENTION**  
 DOOR ROLLERS AND DOOR STRAPS MUST BE CHECKED ON A REGULAR BASIS. DAMAGED OR FRAYED STRAPS MUST BE REPLACED.

Location: Above locking handle

**CAUTION**  
 DO NOT EXCEED MAXIMUM CHASSIS G.V.W.R.  
 WEIGHT MUST BE PROPERLY DISTRIBUTED  
 REF. **MICKEY** WT. ANALYSIS S-13413 OR S-12763

Location: Front bulkhead below locking handle

**WARNING**  
 ALL RESTRAINING DEVICES MUST BE CONNECTED AND HAND TRUCKS MUST BE PROPERLY SECURED PRIOR TO OPERATING VEHICLE. SPRING LATCH ON SWING ARM MUST BE ENGAGED IN THE LOCKED POSITION AND PADLOCK MUST BE SECURED AND LOCKED TO PREVENT ACCIDENTAL DISCHARGE OF HAND TRUCK DURING TRANSPORT.

Location: Next to hand truck rack

**RAISE** **SLOW** **LOWER**  
 (MORE POWER)  
**FAST** (LESS POWER)

(OPTIONAL INFORMATION) Location: Below landing gear crank

**OPEN**  
**CAUTION**  
 CLOSE DOORS BEFORE LOCKING. DOORS MUST BE LOCKED WHEN VEHICLE IS IN MOTION.  
**LOCK**

**OPEN**  
**CAUTION**  
 CLOSE DOORS BEFORE LOCKING. DOORS MUST BE LOCKED WHEN VEHICLE IS IN MOTION.  
**LOCK**

(OPTIONAL INFORMATION) Location: Adjacent to door locking handles

**WARNING**  
 ADJUSTABLE SHELVES MUST BE INSTALLED AT THE SAME ANGLE AS THE FLOOR PITCH. DO NOT OPERATE WITH THE SHELVES IN A LEVEL POSITION.  
**ADVERTENCIA**  
 LOS ANAQUELES AJUSTABLES DEBEN SER INSTALADOS EN EL MISMO ÁNGULO QUE EL TONO DE SUELO. NO FUNCIONE CON LOS ANAQUELES EN UNA POSICIÓN DE NIVEL.

**INCORRECT**  
**INCORRECTO**

**CORRECT**  
**CORRECTO**

(OPTIONAL INFORMATION) Location: Bay Side wall, Adjacent Shelf Bracket



**MICKEY TRUCK BODIES INC**  
**1305 Trinity Ave., P.O. Box 2044, High Point, NC 27261**  
**Tel: 800-334-9061**  
**[www.mickeybody.com](http://www.mickeybody.com)**