

Turbo air Speeds UP the Pace of Innovation

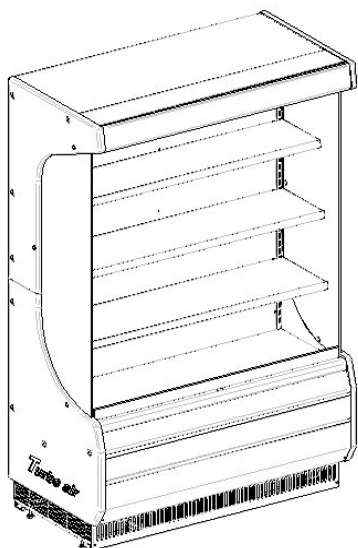

OPEN DISPLAY MERCHANDISER

Installation and Operation Manual

Please read this manual completely before attempting
to install or operate this equipment!



TOM-40(B)

TOM-50(B)

CONTENTS

INTRODUCTION	1
SPECIFICATIONS	3
INSTALLATION INSTRUCTIONS	3~4
Inspection for damage	
Location of Display	
Leveling of Display	
OPERATING INSTRUCTIONS	5
Controls	
Light Switch	
Temperature Control	
Thermometer	
How to place product	
MAINTENANCE & CLEANING	6~7
Condenser coil	
TROUBLE SHOOTING	7~8
Display not working	
Display case warm	
Lights not working	
WIRING DIAGRAM	8
WARRANTY STATEMENT	9~13

INTRODUCTION

This owner's manual has important information. Please read the entire manual before installing your new Turbo Air Open Display Merchandiser. After reading manual if you have any questions, please call:

CUSTOMER SERVICE DEPARTMENT

**TURBO AIR
1250 VICTORIA ST.
CARSON, CA 90746
1-800-381-7770**

Please write down model and serial number for making any reference to this unit.

MODEL NUMBER _____

SERIAL NUMBER _____

WARNING!

Failure to read this manual completely can result in personal injury or damage to the unit.

Keep manual in a safe place to refer to in the future.

WARNING!

Display should be on dedicated outlet for proper operation.

Thank you for purchasing Turbo Air!

SPECIFICATION

Model	TOM – 40(B)	TOM – 50(B)
Dimension (W×D×H)	26.83×38.99×77.98 in	26.83×50.39×77.98 in
Electricity	120V/1Ph/60Hz	
Power Input	1,920 W	1,953 W
Compressor	CAJ9513Z	
Refrigerant	R-404a	
Lighting	25W×5	32W×5
Type of Defrosting	Timed off defrost	
Weight of Case	507 lbs	573 lbs

INSTALLATION INSTRUCTIONS

INSPECTION FOR DAMAGE

Customer is responsible for checking for damage. First inspect crate as soon as it arrives. Prior to signing if crate is damaged make sure you note that on bill of lading.

If after uncrating there is concealed damage and crate was in good condition you must call Customer Service at Turbo Air. Concealed damage must be reported within 24 hours of receiving unit. Bill of lading will be requested faxed to claim department. Pictures may be requested of unit and crating.

LOCATION OF OPEN DISPLAY MERCHANDISER

Display is designed to be in an ambient 75 degrees Fahrenheit (dry bulb) or colder and 55 percent relative humidity. If unit is installed in a warm ambient Display will not cool effectively. Move the display to the final location before removing shipping skid. Allow 3 inches from back of Display to wall. Condenser is in front of Display. Do not block inlet.

There are four bolts at bottom of display that secure it to shipping skid, remove all four.

LEVELING OF OPEN DISPLAY MERCHANDISER

Four leveling legs are provided for leveling Display. If you do not wish to use levelers they can be turned inwards.

Bottom frame of unit will be on floor. Use a leveler to make sure unit is leveled on all four corners.

If unit is not leveled drainage of water will not drain properly. Leveling legs can be adjusted accordingly.

OPERATING INSTRUCTIONS

After installing unit and all electrical to the Display, Display is ready to start up.

CONTROLS

LIGHT SWITCH: It is located on top right hand side by display.

TEMPERATURE CONTROL :

1) Temperature controller is located on the right side of intake grill and it's set at 38~40°F under the ambient temperature of 75°F & humidity of 55RH.

2) Initial setting of TOM-50 is at level 2 and TOM-40 at level 1. If icing is seen, adjust the level knob slightly to 3 to 4 (counterclockwise).

3) To raise the temperature of the cabinet, turn the knob counterclockwise.

THERMOMETER:

Thermometer showing temperature is located on the right side of the back panel under the forth shelf.

*** NOTE:**

Before placing products to the Display unit, wait until the unit to reach desired temperature.

Do not place hot product in unit.

HOW TO PLACE PRODUCT:

Do not overload product on shelves.

Do not place product against back wall, due to air flow will be blocked and cause the unit not to cool properly.

MAINTENANCE & CLEANING

!!! Always before cleaning Display, the unit should be turned off at power switch and lights should be turned off.

Remove product and allow the display unit to reach room temperature

!!! Do not wet electrical components.

DISPLAY CASE SHOULD BE CLEANED THOROUGHLY BEFORE FIRST USE.

a. Do not clean with harsh detergents. Use a mild soap

b. Remove all products.

c. Remove shelves and bottom trays.

d. Clean interior with warm water and mild detergent.

e. Wipe with damp cloth. Do not leave residue of soap.

CONDENSER COIL

Condenser coil is located at bottom behind panel.

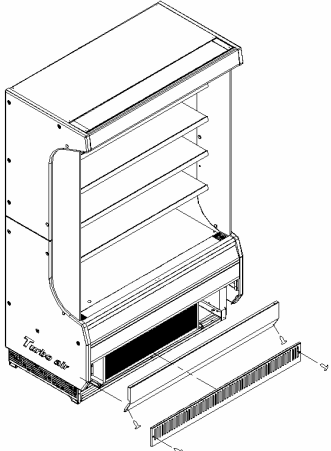

1. Disconnect the electrical power to the unit
2. Remove the front cover and base cover with screwdriver
3. Brush the dirt, lint, etc from the finned condenser coil.
4. When finished, be sure to replace the front cover and base cover
5. Reconnect the electrical power to the unit.
6. Condenser should be cleaned every 3 months or as needed.

TROUBLE SHOOTING

For any problems with Display please refer to following check list. If still having a problem or need to ask a question please call Customer service at 1-800-381-7770.

DISPLAY NOT WORKING

- a. Check to see if breaker is not tripped.
- b. Check power going to unit.

- c. Check power switch is on.

DISPLAY CASE WARM

- a. Check condenser to see if clean
- b. Check that air flow inside of unit is not blocked with product.

LIGHTS NOT WORKING

- a. Check that light switch is on.
- b. Check that light is in lamp holder correctly.

WIRING DIAGRAM

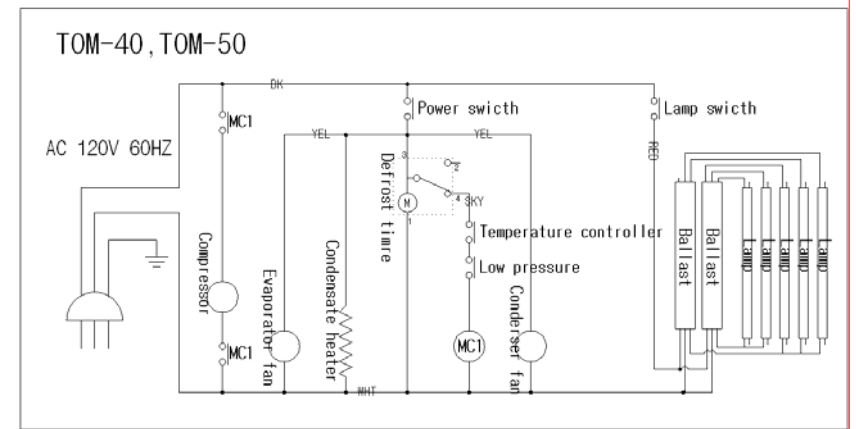

WARRANTY STATEMENT

Warranty claims

All claims for labor or parts must be made directly through Turbo Air. If unit was manufactured more than one year, proof of purchase must be faxed in or sent with claim.

All claims should include: model number of the unit, the serial number of the cabinet, and all pertinent information supporting the existence of the alleged defect. If compressor is replaced under warranty,

Turbo Air either requests the compressor or compressor tag be returned. Compressor or tag must be returned with all information related to the unit.

Any action or breach of these warranty provisions must be commenced within six months after said cause of action has occurred.

One Year Parts & Labor Warranty

Turbo Air warrants to the original purchaser of every new Turbo Air refrigerated unit, the cabinet and all parts thereof, to be free from defects in material or workmanship, under normal and proper use and maintenance service as specified by Turbo Air and upon proper installation and start- up in Accordance with the instruction packet supplied with each Turbo Air unit. Turbo Air's obligation under this warranty is limited to a period of one (1) year from the date of original installation or 15 months after shipment date from Turbo Air, whichever occurs first. Any parts, covered under this warranty, that are determined by Turbo Air to have been defective within one(1) year of original installation or fifteen(15) months after.

Shipment date from manufacture, whichever occurs first, is limits to the repair or replacement, including labor charges, of defective parts or assemblies. The labor Warranty shall include standard straight time labor charges only and reasonable travel time, as determined by Turbo Air

Additional Four Year compressor Warranty

In addition to the one (1)year warranty stated above, Turbo Air warrants its hermetically sealed compressor to be free from defects in both material and workmanship under normal and proper use and maintenance service for a period of four(4) additional years from the date of original installation, but not to exceed five(5) years and three(3) months after shipment from the manufacturer. Compressor determined by Turbo Air to have been defective within this extended period will, at Turbo Air's option, be either repaired or replaced with a compressor or compressor parts of similar design and capacity. The four(4) year extended compressor warranty applies only to hermetically sealed parts of the compressor and does not apply to any other parts or components, including, but not limited to, cabinet, paint finish, temperature control, refrigerant, metering device, driers, motor starting equipment, fan assembly or and other electrical component, etcetera.

404a/134a Compressor warranty

The four-year compressor warranty detailed above will be voided if the following Procedure is not carefully adhered to:

- 1.This system contains R404A or R134A refrigerant and polyolester lubricant The polyol ester lubricant has rapid moisture adsorbing qualities
- 2.Drier replacement is very important and must be changed when a system is opened for servicing. A 032 drier or better is highly recommended.
- 3.Micron level vacuums must be achieved to insure low moisture levels in the system. 500 microns or lower must be obtained.
- 4.When compressor is grounded, suction filter drier and 620 drier or better must be replaced.
- 5.Compressor must be obtained through Turbo Air inc. unless otherwise specified in writing, through Turbo Air's warranty department.

What is not covered by this warranty

Turbo Air's sole obligation under this warranty is limited to either repair or replacement of parts, subject to the additional limitations below. This warranty neither assumes nor authorizes any person to assume obligations other than those expressly covered by this warranty.

No consequential damages

Turbo Air is not responsible for economic loss; profit loss or special, indirect, or consequential damages, including without limitation, losses or damages arising from food or product spoilage claims whether or not on account of refrigeration failure.

Warranty is not transferable This warranty is not assignable and applies only in favor of the original purchaser/ user to whom delivered. Any such assignment or transfer shall void the warranties herein made and shall void all warranties, express or implied, including any warranty of merchantability or fitness for a particular purpose.

Improper usage Turbo Air assumes no liability for parts or labor coverage for component failure or other damages resulting from improper usage or installation or failure to clean and/ or maintain product as set forth in the warranty packet provided with the unit.

Alteration, neglect, Abuse, Misuse, Accident, Damage During Transit or Installation, Fire, Flood, Acts of god.

Turbo Air is not responsible for the repair or replacement of any parts that TurboAir determines have been subjected after the date of manufacture to alteration, neglect, abuse, misuse, accident, damage during transit or installation, fire, flood or act of God.

Improper electrical Connections :

Turbo Air is not responsible for the repair or replacement of failed or damaged components resulting from electrical power failure, the use of extension cords, low voltage, or voltage drops to the unit.

No Implied Warranty of Merchantability or fitness for a Particular purpose :

There are warranties, express, implied or statutory, except the one (1) year warranty and the additional four (4) year compressor warranty no other as described above. These warranties are exclusive and in lieu of all other warranties, including implied warranty and merchantability or fitness for a particular purpose. There are no warranties which extend beyond the description on the face hereof.

Outside U.S. and Canada :

This warranty does not apply to, and Turbo Air is not responsible for, any warranty claims made on products sold or used outside the United States and Canada.



1250 Victoria Street
CARSON, CA 90746
TEL: 310-900-1000
FAX: 310-900-1077
Toll Free: 1-800-627-0032
(U.S.A and Canada)
<http://www.turboairinc.com>