



website: <http://www.lgservice.com>
e-mail : <http://www.lgservice.com/techsup.html>

MICROWAVE OVEN

SERVICE MANUAL

MODEL : LRM1230W
LRM1230B

CAUTION

BEFORE SERVICING THE UNIT, READ THE SAFETY PRECAUTIONS IN THIS MANUAL.

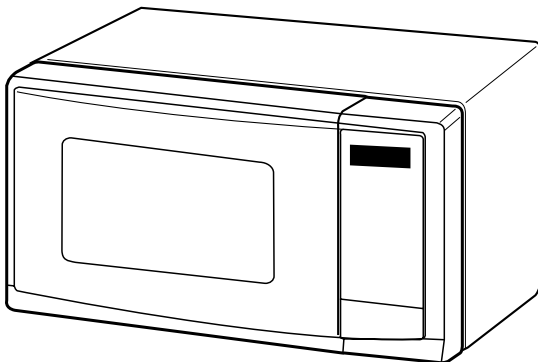

SAFETY PRECAUTIONS

This device is to be serviced only by properly qualified service personnel.

Consult the service manual for proper service procedures to assure continued safety operation and for precautions to be taken to avoid possible exposure to excessive microwave energy.

PRECAUTIONS TO BE OBSERVED BEFORE AND DURING SERVICING TO AVOID POSSIBLE EXPOSURE TO EXCESSIVE MICROWAVE ENERGY

- A) Do not operate or allow the oven to be operated with the door open.
- B) Make the following safety checks on all ovens to be serviced before activating the magnetron or other microwave source, and make repairs as necessary; (1) interlock operation, (2) proper door closing, (3) seal and sealing surfaces (arcing, wear, and other damage), (4) damage to or loosening of hinges and latches, (5) evidence of dropping or abuse.
- C) Before turning on microwave power for any service test or inspection within the microwave generating compartments, check the magnetron, wave guide or transmission line, and cavity for proper alignment, integrity, and connections.
- D) Any defective or misadjusted components in the interlock, monitor, door seal, and microwave generation and transmission systems shall be repaired, replaced, or adjusted by procedures described in this manual before the oven is released to the owner.
- E) A microwave leakage check to verify compliance with CSA should be performed on each oven prior to release to the owner.

CONTENTS

(Page)

SAFETY PRECAUTIONS	Inside front cover
SPECIFICATIONS	1-1
CAUTIONS	2-1
INSTALLATIONS	3-1
OPERATING INSTRUCTIONS	4-1
FEATURES.....	4-1
CONTROL PANEL	4-1
OPERATING SEQUENCE.....	4-2
SCHEMATIC DIAGRAM	4-4
CIRCUIT DESCRIPTION	4-5
SERVICE INFORMATION	5-1
TOOLS AND MEASURING INSTRUMENTS.....	5-1
MICROWAVE LEAKAGE TEST	5-1
MEASUREMENT OF MICROWAVE POWER OUTPUT	5-3
DISASSEMBLY AND ADJUSTMENT.....	5-3
INTERLOCK CONTINUITY TEST.....	5-7
COMPONENT TEST PROCEDURE	5-8
TROUBLE SHOOTING	5-11
EXPLODED VIEW	6-1
DOOR PARTS.....	6-2
CONTROLLER PARTS.....	6-3
OVEN CAVITY PARTS.....	6-4
LATCH BOARD PARTS.....	6-5
INTERIOR PARTS.....	6-6
BASE PLATE PARTS.....	6-7
REPLACEMENT PARTS LIST	7-1
SCHEMATIC DIAGRAM OF P.C.B.	8-1
PRINTED CIRCUIT BOARD.....	8-2
P.C.B. PARTS LIST	9-1

SPECIFICATIONS

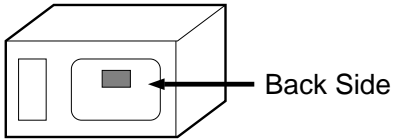
ITEM	DESCRIPTION
MODEL	LRM1230W/LRM1230B
Power Requirement	120 Volts AC 60 Hz 1,650 Watts (13.8 A) Single phase, 3 wire grounded
Power Output	1,200 Watts full microwave power (IEC705)
Microwave Frequency	2,450 MHz
Magnetron	2M246
Timer	0 ~ 99 min. 99 sec.
Outside Dimensions	21 ⁷ / ₈ " (W) x 12 ¹ / ₂ " (H) x 17 ¹ / ₈ " (D)
Cavity Dimensions	14 ¹¹ / ₁₆ " (W) x 9 ⁵ / ₈ " (H) x 15 ⁵ / ₈ " (D)
Net Weight	36.5 lbs (approx.)
Shipping weight	41.5 lbs (approx.)
Control Complement	Touch Control System Clock : 1:00 - 12:59 Microwave Power for Variable Cooking Power level HIGH -----Full power throughout the cooking time 9 (Saute) -----approx. 90% of Full power, 8 (Reheat) -----approx. 80% 7 (Med.-High)-----approx. 70%, 6 (Medium) -----approx. 60% 5 (Med.-Low) -----approx. 50%, 4 (Defrost) -----approx. 40% 3 (Low) -----approx. 30%, 2 (Simmer)-----approx. 20% 1 (Warm)-----approx. 10%
Nameplate Location	
Accessories	Owner's manual & cooking guide Glass turntable Rotating ring
This microwave oven is designed for household use only. It is not recommended for commercial purposes.	

CAUTIONS

Unlike other appliances, the microwave oven is high-voltage and high-current equipment. Though it is free from danger in ordinary use, extreme care should be taken during repair.

- DO NOT operate on a 2-wire extension cord during repair and use.
- NEVER TOUCH any oven components or wiring during operation.
- BEFORE TOUCHING any parts of the oven, always remove the power plug from the outlet.
- For about 30 seconds after the oven stops, an electric charge remains in the high voltage capacitor. When replacing or checking, you must discharge the high voltage capacitor by shorting across the two terminals with an insulated screwdriver.

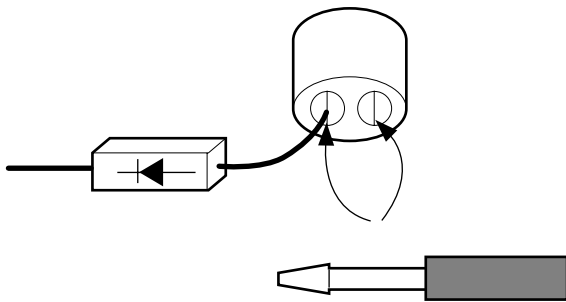

- Remove your watches whenever working close to or replacing the Magnetron.
- DO NOT touch any parts of the control panel circuit. A resulting static electric discharge may damage this P.C.B.
- NEVER operate the oven with no load.
- NEVER injure the door seal and front plate of the oven cavity.
- NEVER put iron tools on the magnetron.
- NEVER put anything into the latch hole and the interlock switches area.

MICROWAVE RADIATION

Personnel should not be exposed to the microwave energy which may radiate from the magnetron or other microwave generating device if it is improperly used or connection. All input and output microwave connections, waveguide, flange, and gasket must be secure never operate the device without a microwave energy absorbing load attached. Never look into an open waveguide or antenna while the device is energized.

- Proper operation of the microwave oven requires that the magnetron be assembled to the waveguide and cavity. Never operate the magnetron unless it is properly installed.
- **Be sure that the magnetron gasket is properly installed around the dome of the tube whenever installing the magnetron.**

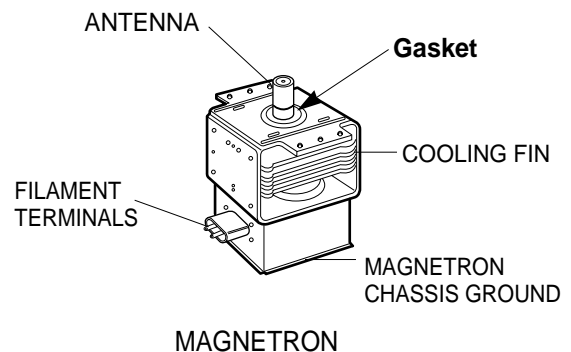

THE OVEN IS TO BE SERVICED ONLY BY PROPERLY QUALIFIED SERVICE PERSONNEL.

INSTALLATIONS

BEFORE YOU BEGIN, READ THE FOLLOWING INSTRUCTIONS COMPLETELY AND CAREFULLY.

INSTALLING

1. Empty the microwave oven and clean inside it with a soft, damp cloth. Check for damage such as misaligned door, damage around the door or dents inside the cavity or on the exterior.
2. Put the oven on a counter, table, or shelf that is strong enough to hold the oven and the food and utensils you put in it. (The control panel side of the oven is the heavy side. Use care when handling.)
3. Do not block the vent and the air intake openings. Blocking vent or air intake openings can cause damage to the oven and poor cooking results. Make sure the microwave oven legs are in place to ensure proper air flow.
4. The oven should not be installed in any area where heat and steam are generated, because they may damage the electronic or mechanical parts of the unit.
Do not install the oven next to a conventional surface unit or above a conventional wall oven.
5. Use microwave oven in an ambient temperature less than 104°F(40°C).
6. Place the microwave oven on a sturdy and flat surface at least 10 cm(4 inches) from the wall.
7. Place the microwave oven as far away as possible from TV, RADIO, COMPUTER, etc., to prevent interference.

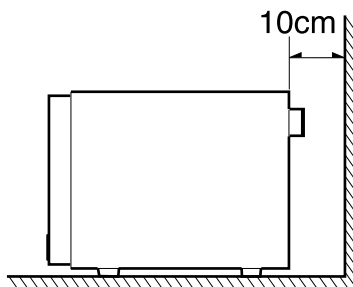

GROUNDING INSTRUCTIONS

For personal safety, this appliance must be fully grounded at all times.

In the event of an electrical short circuit, grounding reduces the risk of electrical shock.

The plug must be plugged into an outlet that is properly installed and grounded.

WARNING

Improper use of the grounding plug can result in a risk of electric shock.

Do not, under any circumstances, cut or remove the third ground prong from the power cord plug.

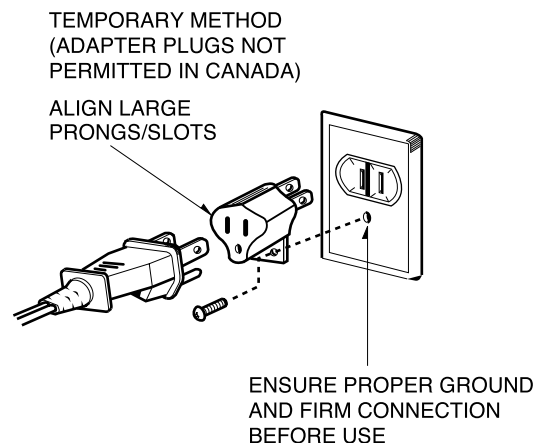
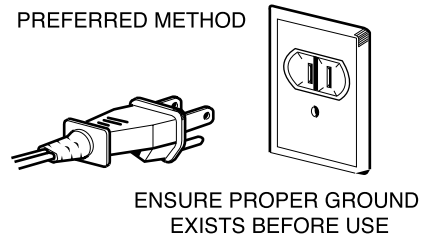

OPERATING INSTRUCTIONS

FEATURES

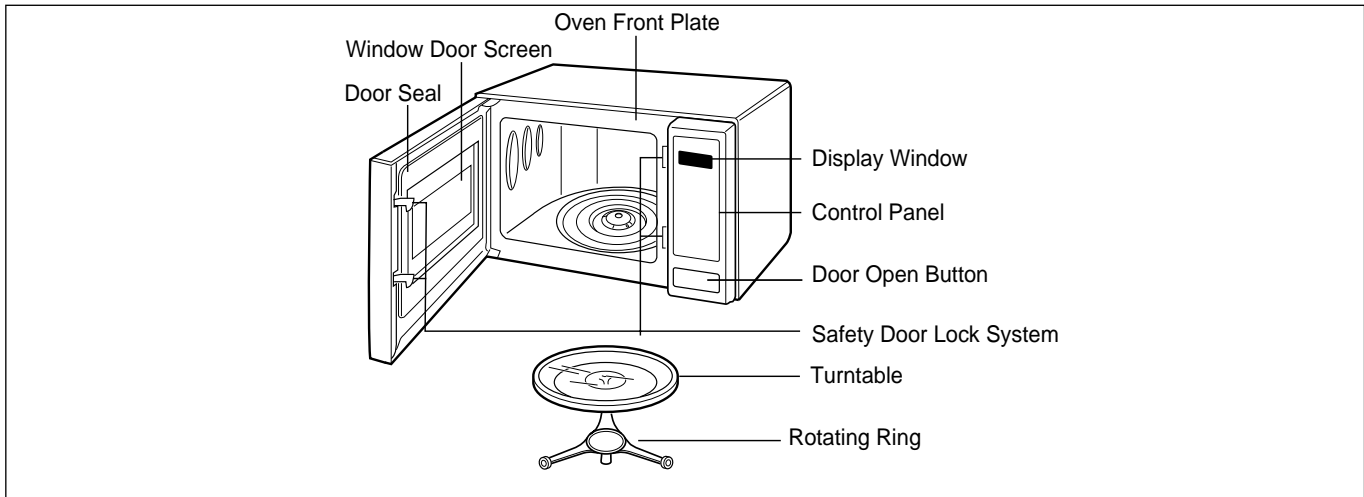

CONTROL PANEL

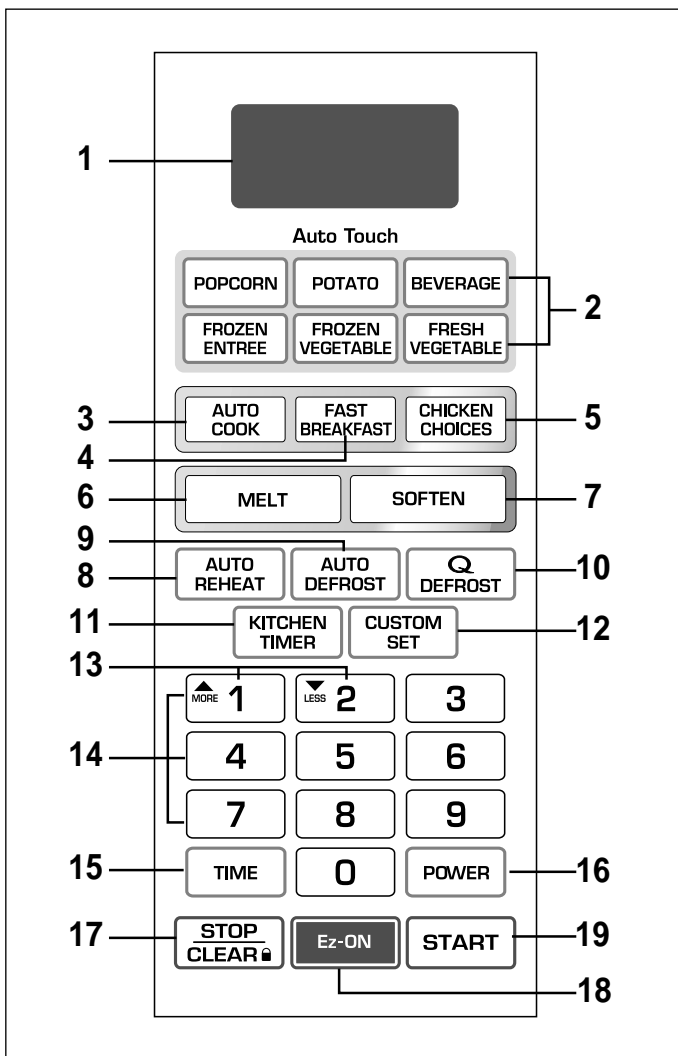

- 1. DISPLAY:** The display includes a clock and indicators that tell you the time of day, cook time settings, and cooking functions selected.
- 2. AUTO TOUCH:** Touch this pad to cook without entering a cook time or power.
- 3. AUTO COOK:** Touch this pad to cook without entering a cook time or power.
- 4. FAST BREAKFAST:** Fast breakfast has 6 food categories of preset cook time or power.
- 5. CHICKEN CHOICES:** Chicken choices have 4 food categories of preset cook time or power.
- 6. MELT :** Touch this pad to melt chocolate, cheese, butter, or marshmallows.
- 7. SOFTEN :** Touch this pad to soften ice cream, cream cheese, butter, or frozen juice.
- 8. AUTO REHEAT:** Touch this pad to reheat without entering a cook time or power.
- 9. AUTO DEFROST:** Touch this pad to defrost foods by entering weight.
- 10. Q-DEFROST:** Touch this pad to defrost foods quickly.
- 11. KITCHEN TIMER :** Touch this pad to use your microwave oven as a kitchen timer.
- 12. CUSTOM SET:** Touch this pad to select sound control, time of day, clock Off or On, scroll speed, lbs /kg choice.
- 13. MORE / LESS :** All of the one touch cook and Timed Cook can be adjusted to cook food for a longer or shorter time.
 - MORE → Press MORE will add 10 seconds to the cooking time.
 - LESS → Press LESS will subtract 10 seconds to the cooking time.
- 14. NUMBER PADS :** Touch number pads to enter cook time, power level, quantities, or weights.
- 15. TIME :** Touch this pad to set a cook time.
- 16. POWER :** Touch this pad to set a cook power.
- 17. STOP/CLEAR :** It used to stop oven and clear all entries except time day.
- 18. Ez-ON :** You can extend cooking time in multiples of 30 seconds by repeatedly touching this pad during cooking.
- 19. START :** This feature allows oven to begin functioning.

OPERATING SEQUENCE

The following is a description of component functions during oven operation.

1. CANCEL FUNCTION

Touch the **STOP/CLEAR** pad whenever you need to cancel an entry or a function currently in use. The display will return either to the last item entered or to the clock.

2. EZ ON

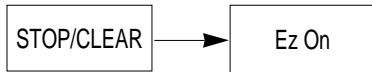

3. AUTO TOUCH



NOTE: • Heat only 1 package at a time
• Then the oven will start automatically.

4. TIME COOKING

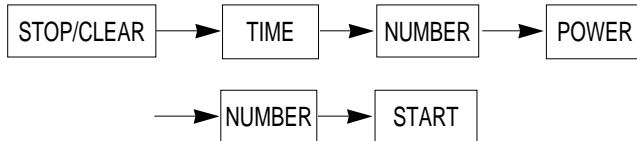

5. MULTI-STAGE COOKING

You can program your oven to switch from one power level to another for up to 3 stages. To set a 2-stage cook cycle.

■ 1ST STAGE

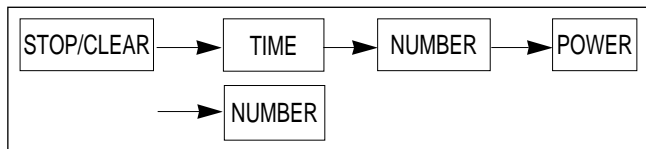

■ 2ND STAGE

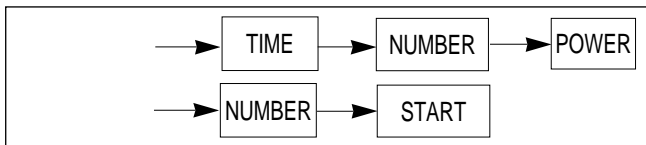

6. AUTO DEFROST COOKING

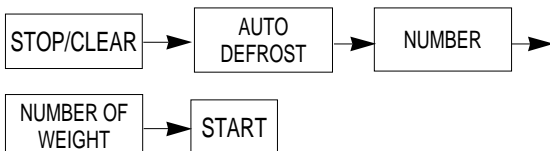

7. CHILD LOCK

This oven has a CHILD LOCK feature TO SET CHILD LOCK

- Touch **STOP/CLEAR** pad.
- Touch and hold **STOP/CLEAR** pad → **LOCKED** appears on the display.

TO CANCEL CHILD LOCK

- Touch and hold **STOP/CLEAR** pad → **LOCKED** disappears.

8. MORE / LESS

The cook time is adjustable by MORE pad or LESS pad

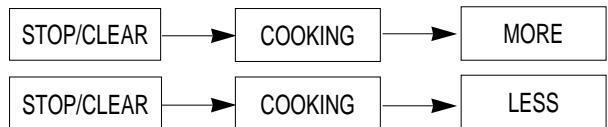

9. AUTO REHEAT



NOTE: Then the oven will start automatically.

10. Q - DEFROST

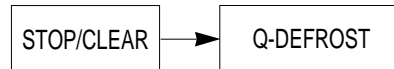

11. KITCHEN TIMER



12. FAST BREAKFAST



NOTE: Then the oven will start automatically.

13. CHICKEN CHOICES



NOTE: Then the oven will start automatically.

14. MELT



NOTE: Then the oven will start automatically.

15. SOFTEN



NOTE: Then the oven will start automatically.

16. AUTO COOK

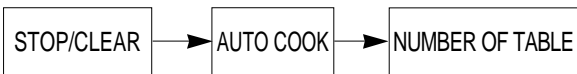

NOTE: Then the oven will start automatically.

17. CUSTOM SET



NOTE: Then the oven will start automatically.

SCHEMATIC DIAGRAM

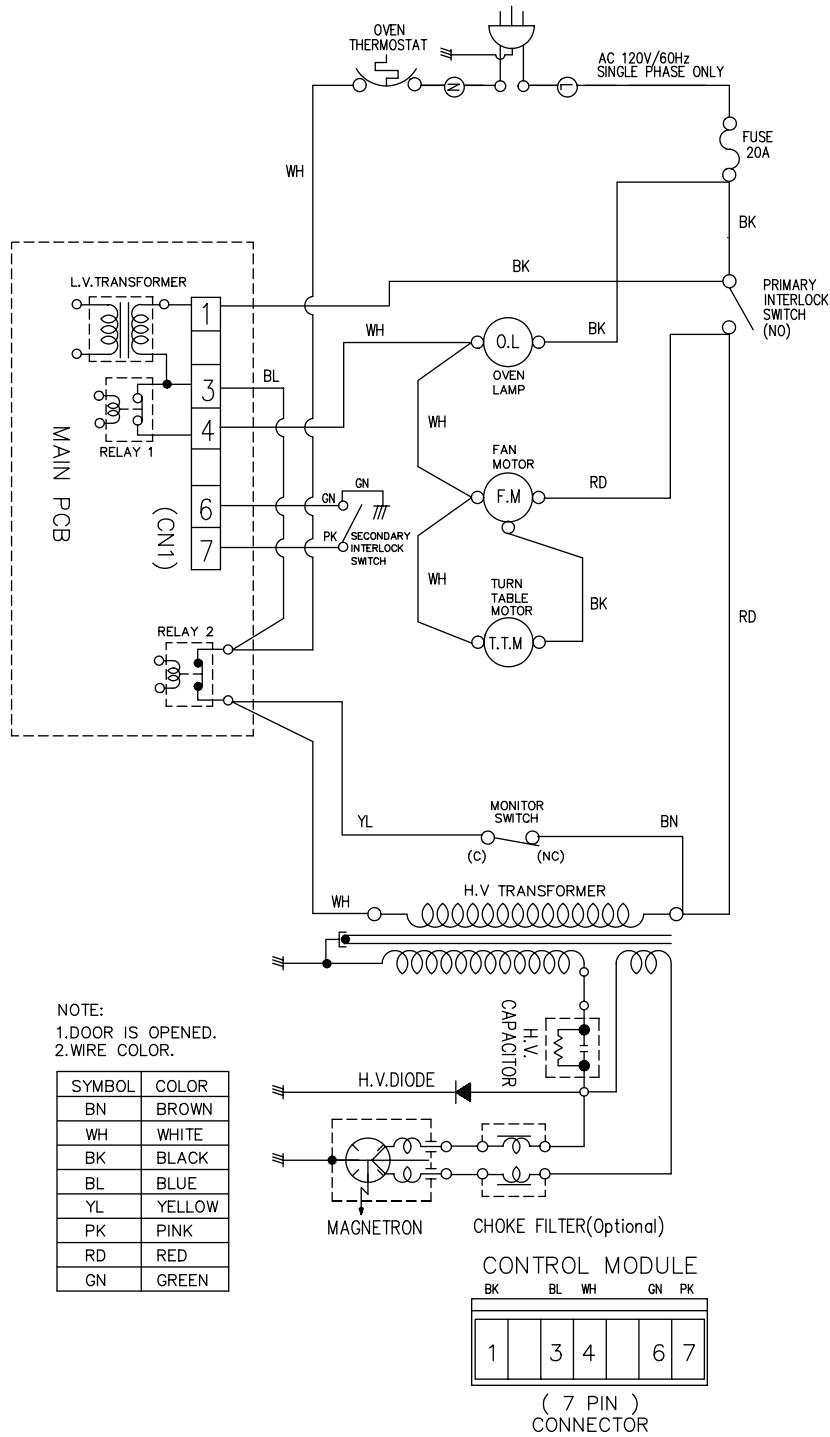

IMPORTANT SAFETY NOTE: THE SHADED AREAS ON THIS SCHEMATIC DIAGRAM INCORPORATE SPECIAL FEATURES IMPORTANT FOR PROTECTION FROM MICROWAVE RADIATION, FIRE, ELECTRICAL SHOCK, AND HAZARDS. WHEN SERVICING IT IS ESSENTIAL THAT ONLY MANUFACTURER'S SPECIFIED PARTS BE USED FOR THE CRITICAL COMPONENTS IN THE SHADED AREAS OF THE SCHEMATIC DIAGRAM.

NOTICE: SINCE THIS IS BASIC SCHEMATIC DIAGRAM, THE VALUES OF COMPONENTS AND SOME PARTIAL CONNECTIONS ARE SUBJECT TO CHANGE FOR IMPROVEMENT.

CIRCUIT DESCRIPTION

GENERAL DETAILS

- The low voltage transformer supplies the necessary voltage to the micom controller when power cord is plugged in.
- When the door is closed, the primary switch is ON, the secondary switch is ON, and the monitor switch opens (contact COM and NO).

WHEN SELECTING COOKING POWER LEVEL AND TIME

- The micom controller memorizes the function you set.
- The time you set appears in the display window.
- Each indicator light turns on to indicate that the stage has been set.

WHEN TOUCHING THE START PAD

- The coil of the relay is energized by the micom controller.
- Power input is supplied to the high voltage transformer through the fuse to the primary switch and relay 2.
- Turntable rotates.

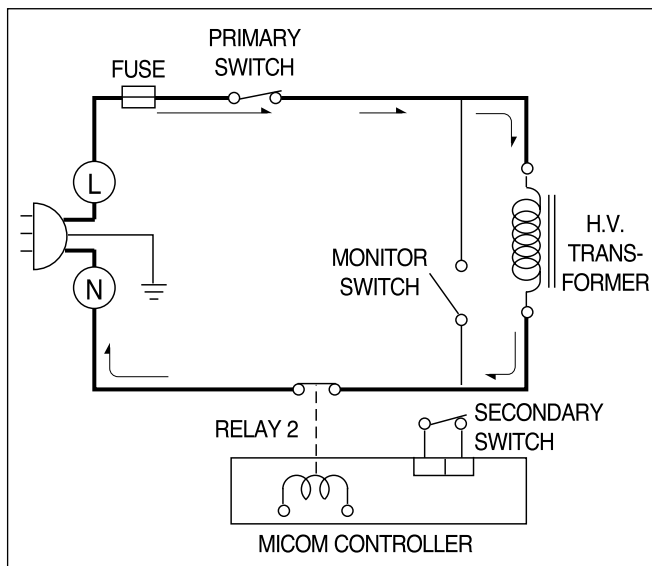

- The fan motor rotates and cools the magnetron by blowing the air (coming from the intake on the base-plate).
- The air is also directed into the oven to exhaust the vapor in the oven through the upper plate.
- Cooking time starts counting down.
- 3.3 volts AC is generated from the filament winding of the high voltage transformer. This 3.3 volts is applied to the magnetron to heat the magnetron filament through two noise-preventing choke coils.

- A high voltage of approximately 2100 volts AC is generated in the secondary of the high voltage transformer which is increased by the action of the high voltage diode and charging of the high voltage capacitor.
- The negative 4,000 Volts DC is applied to the filament of the magnetron.

WHEN THE OVEN IS SET AT ANY LEVEL EXCEPT MAXIMUM.

- The micom controller controls the ON-OFF time of relay 2 by the applied signal to vary the average output power of microwave oven as POWER LEVEL. (refer to page 1-1)
- One complete cycle of relay 2 is 22 seconds.

WHEN THE DOOR IS OPENED DURING COOKING

- Both the primary switch and relay 2 cut off the primary winding voltage of the high voltage transformer.
- ON-OFF of relay 2 is coupled electrically with opening and closing of the secondary switch.
- When the door is opened, the secondary switch is opened and when the door is closed, the secondary switch is closed.
- The cooking time stops counting down.
- Relay stops functioning.
- As the door is opened, if the contact of primary switch and relay2 and/or secondary switch fail to open, the fuse opens due to the large current surge caused by the monitor switch activation, which in turn stops magnetron oscillation.

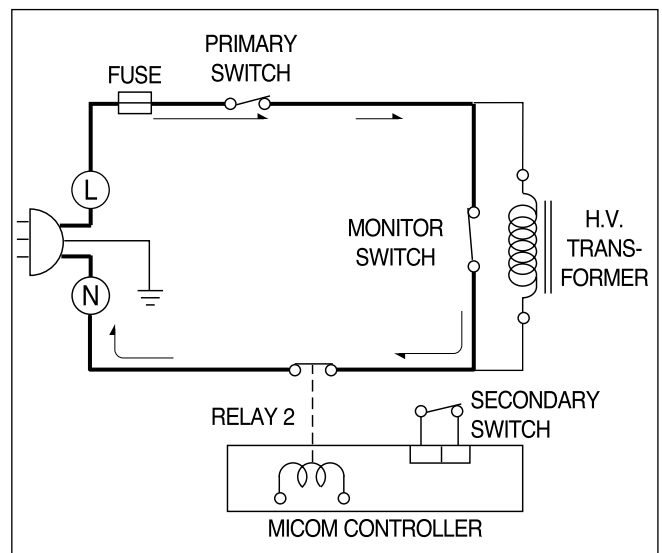

SERVICE INFORMATION

TOOLS AND MEASURING INSTRUMENTS

NECESSARY TOOLS

Tools normally used for TV servicing are sufficient. Standard tools are listed below.

- Diagonal pliers
- Long nose pliers
- Phillips screwdriver
- Flat blade screwdriver
- Wrench (size 5mm)
- Nutdriver (size 5mm)
- Adjustable wrench
- Soldering iron
- Solder
- Vinyl insulation tape
- Polishing cloth

NECESSARY MEASURING INSTRUMENTS

- TESTER (VOLTS-DC, AC, Ohmmeter)
- Microwave survey meter
 - Holaday HI-1500
HI-1501
 - Narda 8100
8200
- Inch scale
- 600 cc non conductive material beaker (glass or plastic),
inside diameter: approx. 8.5 cm (3¹/₂ in.)
- Cylindrical and made of borosilicate glass vessel.
max. thickness: 3 mm
outside diameter: approx. 190mm
height: approx. 90mm
- Glass thermometer: 100°C or 212°F (1 deg scale)

MICROWAVE LEAKAGE TEST

CAUTIONS

- **Be sure to check microwave leakage prior to servicing the oven if the oven is operative prior to servicing.**
- **The service personnel should inform the manufacture importer, or assembler of any certified oven unit found to have a microwave emission level in excess of 5 mW/cm² and should repair any unit found to have excessive emission levels at no cost to the owner and should ascertain the cause of the excessive leakage. The service personnel should instruct the owner not to use the unit until the oven has been brought into compliance.**
- **If the oven operates with the door open, the service personnel should:**
 - **Tell the user not to operate the oven.**
 - **Contact the manufacturer.**
- The service personnel should check all surface and vent openings for microwave leakage.
- Check for microwave leakage after every servicing. The power density of the microwave radiation leakage emitted by the microwave oven should not exceed 4 mW/cm². Always start measuring of an unknown field to assure safety for operating personnel from radiation leakage.

MEASURING MICROWAVE ENERGY LEAKAGE

- **Pour 275±15cc of 20±5°C(68±9°F) water in a beaker which is graduated to 600 cc, and place the beaker on the center of the turntable.**
- **Set the energy leakage monitor to 2,450 MHz and use it following the manufacturer's recommended test procedure to assure correct result.**
- **When measuring the leakage, always use the 2-inch (5cm) spacer supplied with the probe.**
- **Operate the oven at its maximum output.**
- **Measure the microwave radiation using and electromagnetic radiation monitor by holding the probe perpendicular to the surface being measured**

Move probe along shaded area

////////////////////

Probe scanning speed

Less than 2.5 cm/sec

(1in/sec)

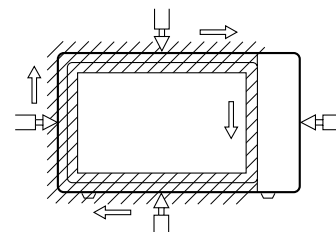

MEASUREMENT WITH OUTER CASE REMOVED

- When you replace the magnetron, measure for microwave energy leakage before the outer case is installed and after all necessary components are replaced or adjusted.
Special care should be taken in measuring the following parts. (Circled area of Fig. below)
 - Around the magnetron
 - The waveguide

WARNING : AVOID CONTACTING ANY HIGH VOLTAGE PARTS

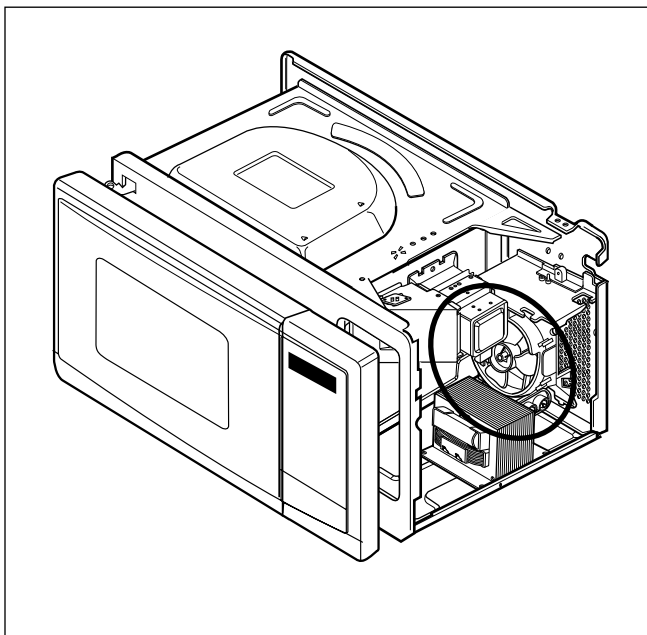

MEASUREMENT WITH A FULLY ASSEMBLED OVEN

- After all components, including the outer case, are fully assembled, measure for microwave energy leakage around the door viewing window, the exhaust opening, and air inlet openings.
- Microwave energy leakage must not exceed the values prescribed below.

NOTE: Leakage with the outer case removed less than 5 mW/cm.sq. Leakage for a fully assembled oven (Before the latch switch (primary) is interrupted) with the door in a slightly opened position-less than 2 mW/cm.sq.

NOTES WHEN MEASURING

- Do not exceed meter full scale deflection.
- The test probe must be moved no faster than 1 inch/sec (2.5 cm/sec) along the shaded area, otherwise a false reading may result.
- The test probe must be held by the grip portion of the handle.
A false reading may result if the operator's hand is between the handle and the probe.
- When testing near a corner of the door, keep the probe perpendicular to the surface making sure the probe horizontally along the oven surface. Hold vertically when testing the top and bottom, and horizontally along.

RECORD KEEPING AND NOTIFICATION AFTER MEASUREMENT

- After adjustment and repair of any microwave energy interruption or microwave energy blocking device, record the measured values for future reference. Also enter the information on the service invoice.
- The microwave energy leakage should not be more than 4 mW/cm.sq. after determining that all parts are in good condition, functioning properly and genuine replacement parts which are listed in this manual have been used.
- At least once a year, have the electromagnetic energy leakage monitor checked for calibration by its manufacturer.

SPECIAL TIP

- This oven used the button head screws.

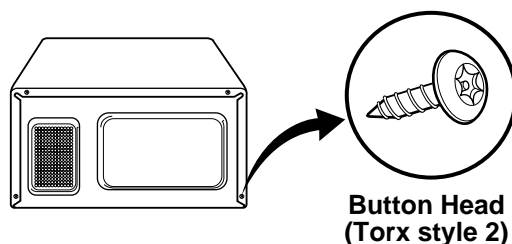

- When you remove the screws, use the tamper-resistant Torx driver having a pin-in-head.

MEASUREMENT OF MICROWAVE POWER OUTPUT

- Microwave power output measurement is made with the microwave oven supplied at its rated voltage and operated at its maximum microwave power setting with a load of (1000±5) g of potable water.
- The water is contained in a cylindrical borosilicate glass vessel having a maximum material thickness of 3 mm and an outside diameter of approximately 190mm.
- The oven and the empty vessel are at ambient temperature prior to the start of the test.
- The initial temperature (T₁) of the water is (10±2)°C It is measured immediately before the water is added to the vessel. After addition of the water to the vessel, the load is immediately placed on the center of the turntable which is in the lowest position and the microwave power switched on.
- The time T for the temperature of the water to rise by a value ΔT of (10±2)° is measured, where T is the time in seconds and ΔT is the temperature rise. The initial and final water temperatures are selected so that the maximum difference between the final water temperature and the ambient temperature is 5°.

- The microwave power output P in watts is calculated from the following formula :

$$P = \frac{4187 \times (\Delta T)}{T}$$

is measured while the microwave generator is operating at full power. Magnetron filament heat-up time is not included. (about 3 sec)

- The water is stirred to equalize temperature throughout the vessel, prior to measuring the final water temperature.
- Stirring devices and measuring instruments are selected in order to minimize addition or removal of heat.

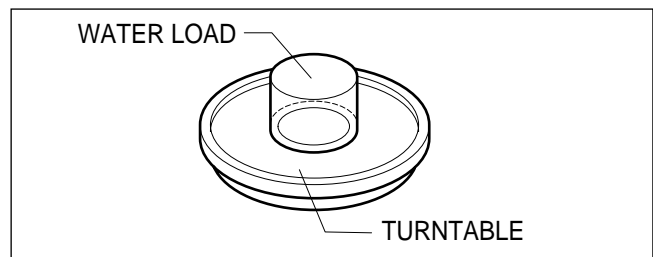

DISASSEMBLY AND ADJUSTMENT

A. OUTER CASE REMOVAL

- 1) Disconnect the power supply cord from the outlet.
- 2) Remove the screws from the rear of the case.
The outer case must be moved backward to be lifted off.

B. POWER SUPPLY CORD

- 1) Remove the outer case.
- 2) Disconnect two terminals and remove one screw of the ground terminal.

C. CONTROL PANEL ASSEMBLY

- 1) Open the door.
- 2) Disconnect the lead wire from RELAY (RY2) of the PCB SUB ASSEMBLY.
- 3) Disconnect the leadwire from connector (CN1) of the PCB SUB ASSEMBLY.
- 4) Remove screw which hold the controller assembly to the cavity.
- 5) Lift up and pull out control panel assembly carefully from the cavity.

CAUTION: DISCHARGE THE HIGH VOLTAGE CAPACITOR BEFORE SERVICING
(refer to page 2-1)

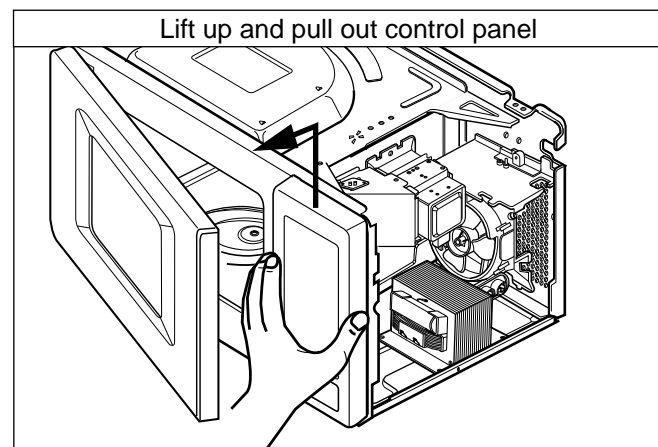
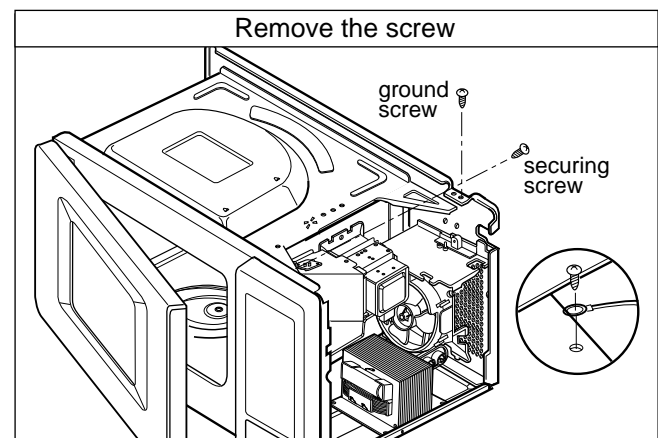

D. PCB ASSEMBLY REMOVAL

- 1) Remove the control panel assembly from the cavity. (Refer to control panel assembly removal on previous page.)
- 2) Remove screws which hold the PCB SUB ASS'Y to the control panel.
- 3) Disconnect the flat cable from the PCB SUB ASS'Y and take off the PCB SUB ASS'Y

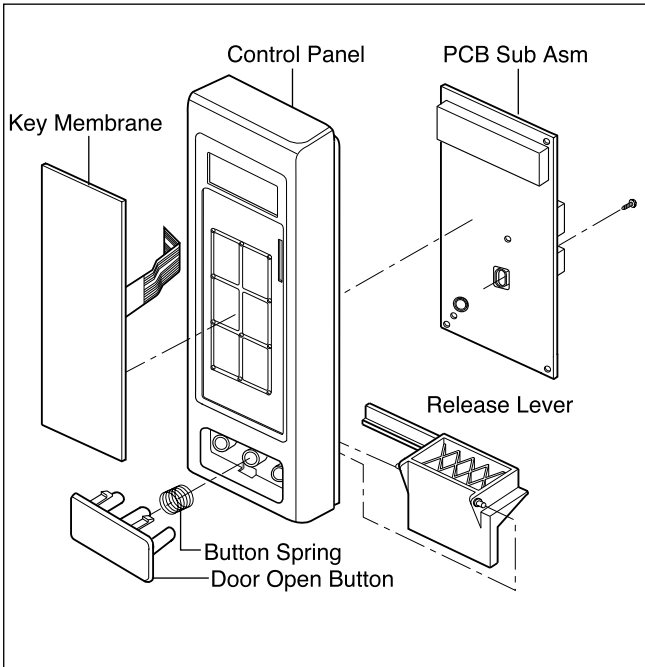

E. DOOR MAIN ASSEMBLY REMOVAL

- 1) Open the door.
- 2) Remove the choke cover very carefully with a flat-blade screwdriver.

CAUTION: Be careful not to damage door seal plate by screwdriver.

- 3) Lift up and push the door.

NOTE:

1. After replacing the door, be sure to check that the primary switch, monitor switch, and secondary switch operate normally.
2. After replacing the door, check for microwave energy leakage with a survey meter. Microwave energy must be below the limit of 4 mW/cm. (with a 275 ml water load)
3. When mounting the door assembly to the oven assembly, be sure to adjust the door assembly parallel to the chassis. Also adjust so the door has no play between the inner door surface and oven frame assembly. If the door assembly is not mounted properly, microwaves may leak from the clearance between the door and the oven.

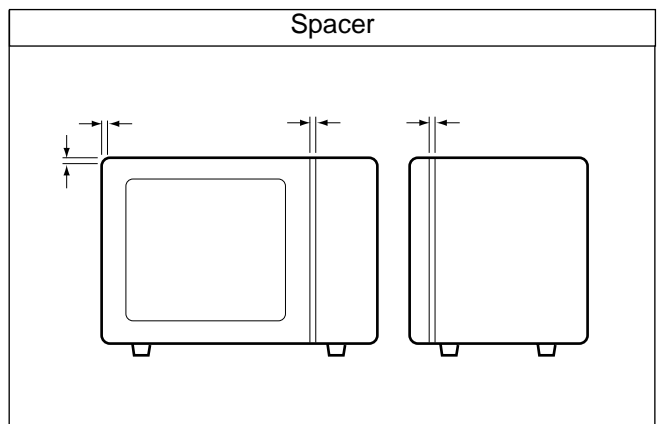
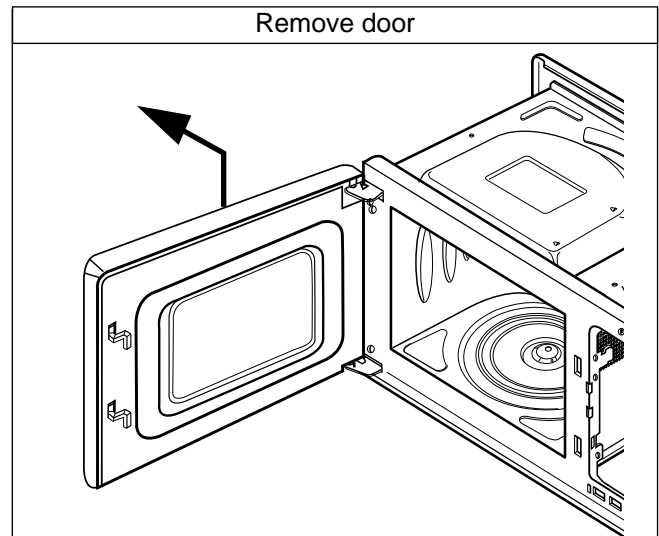
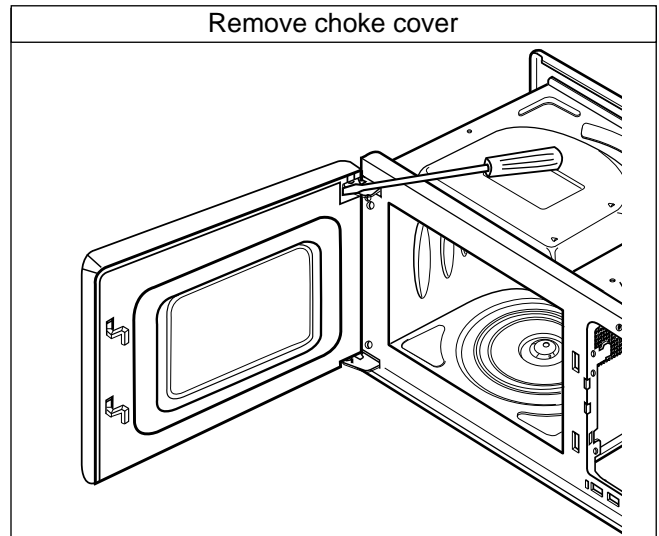

F. AIR DUCT ASSEMBLY REMOVAL

- 1) Disconnect the leadwire from the lamp.
- 2) Remove the mounting screw to the magnetron.

G. MAGNETRON REMOVAL

- 1) Disconnect the leadwire from the magnetron.
- 2) Carefully remove the mounting screws holding the magnetron and the waveguide.
- 3) Remove the magnetron ASS'Y until the tube is clear from the waveguide.

NOTE:

1. When removing the magnetron, make sure its dome does not hit any adjacent parts, or it may be damaged.
2. When replacing the magnetron, be sure to install the magnetron gasket in the correct position and be sure that the gasket is in good condition.
3. After replacing the magnetron, check for microwave leakage with a survey meter around the magnetron. Microwave energy must be below the limit of 5 mW/cm^2 . (With a 275 ml. water load).
Make sure that gasket is rigidly attached to the magnetron. To prevent microwave leakage, tighten the mounting screws properly, making sure there is no gap between the waveguide and the magnetron.

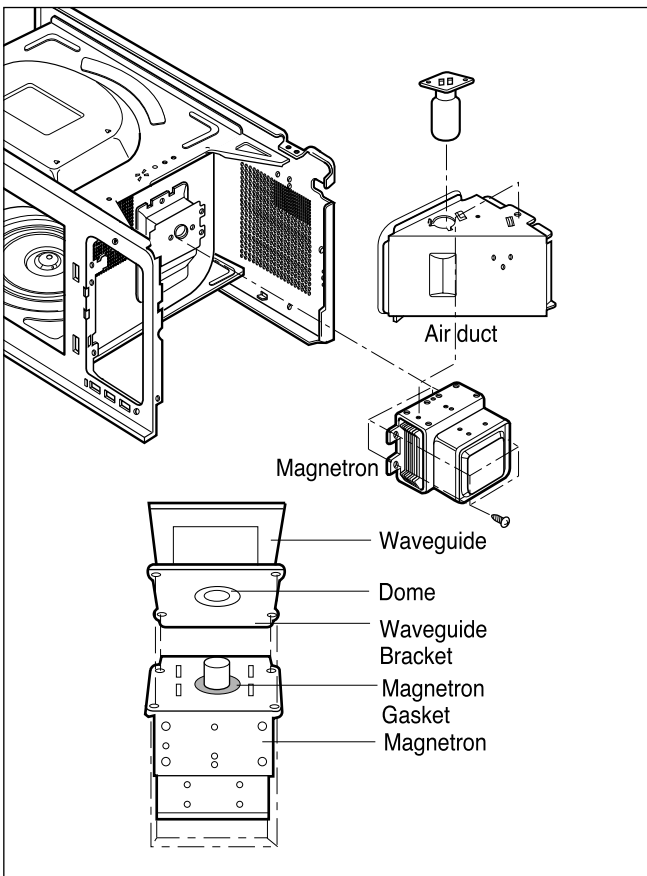

H. REMOVING THE TURNTABLE MOTOR

- 1) Remove the turntable and rotating ring.
- 2) Lay the unit down on its back.
- 3) Remove the turntable motor cover.
The turntable base cover is easily removed by pinching the eight parts with a wire cutting.
- 4) Disconnect the leadwire from the turntable motor terminals.
- 5) Remove the screw securing the turntable motor to the oven cavity ASS'Y
- 6) After repairing the motor, rotate the removed turntable motor cover.
- 7) Fit the turntable motor cover's projecting part to the base plate slit.

NOTE:

1. Remove the wire lead from the turntable motor **VERY CAREFULLY**.
2. Be sure to grasp the connector, not the wires, when removing.

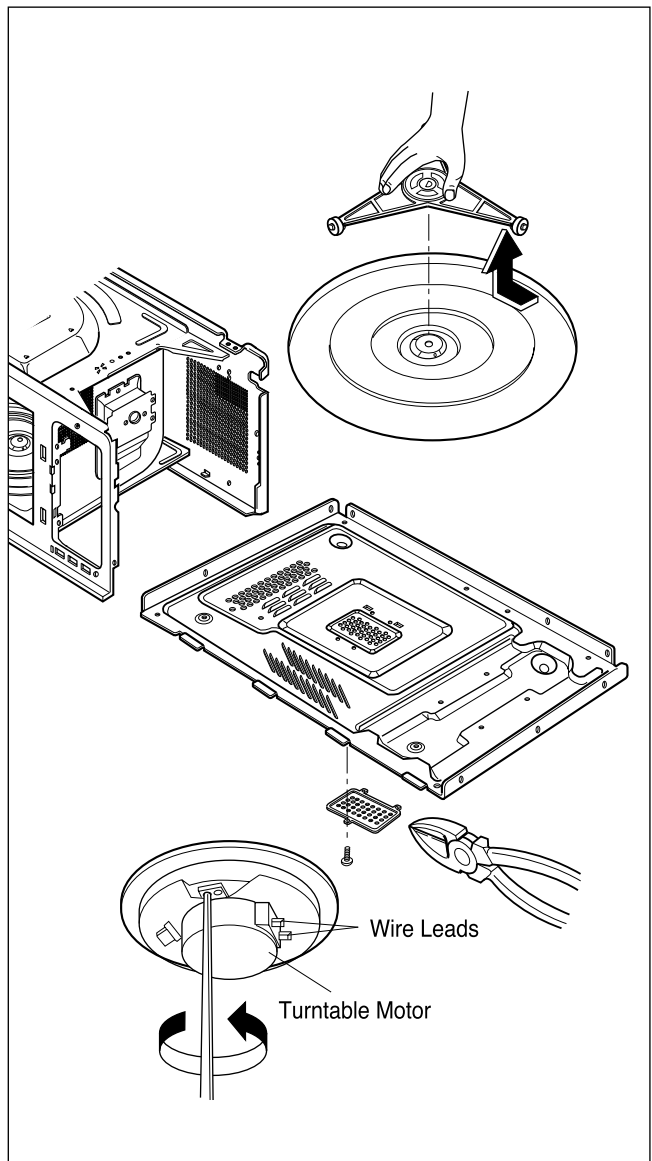

I. HIGH VOLTAGE TRANSFORMER

REMOVAL

- 1) Discharge the high voltage capacitor.
- 2) Disconnect the leadwire from magnetron, high voltage transformer, and capacitor.
- 3) Remove the screw holding the high voltage transformer to the baseplate.

J. FAN MOTOR ASSEMBLY REMOVAL

- 1) Discharge the high voltage capacitor.
- 2) Disconnect the leadwire from fan motor and high voltage capacitor.
- 3) Remove the two screws holding the the suction guide ASS'Y to the oven cavity and remove the high voltage diode earth screw.
- 4) Remove the two screws holding the fan motor ASS'Y to the suction guide ASS'Y.

K. HIGH VOLTAGE CAPACITOR AND DIODE REMOVAL

- 1) Discharge the high voltage capacitor.
- 2) Disconnect the leadwire from fan motor and high voltage capacitor.
- 3) Remove the screw holding the suction guide ASS'Y to the oven cavity and remove the high voltage diode earth screw.
- 4) Remove the screw holding the high voltage capacitor bracket.

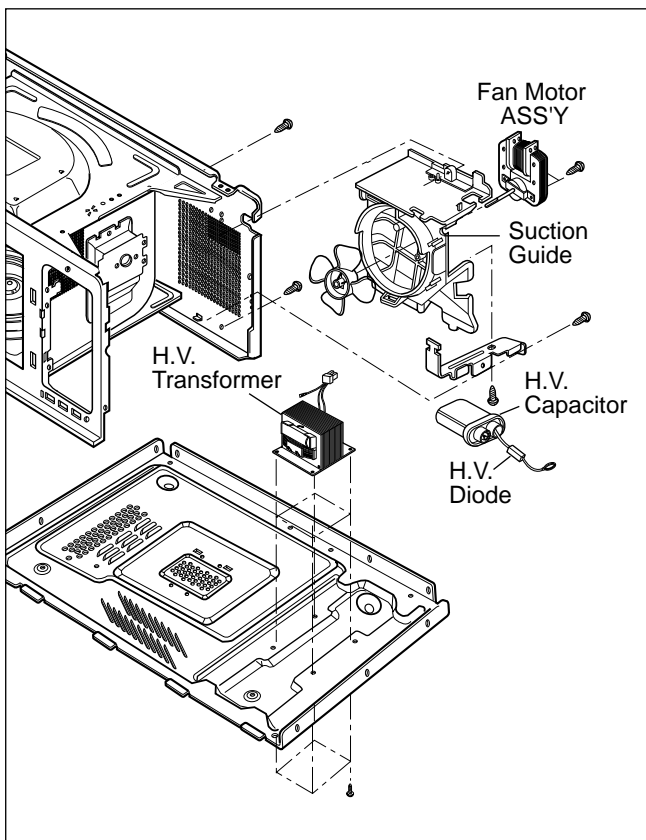

L. INTERLOCK SYSTEM

1) INTERLOCK MECHANISM

The door lock mechanism is a device which has been specially designed to eliminate completely microwave activity when the door is opened during cooking and thus to prevent the danger resulting from the microwave leakage.

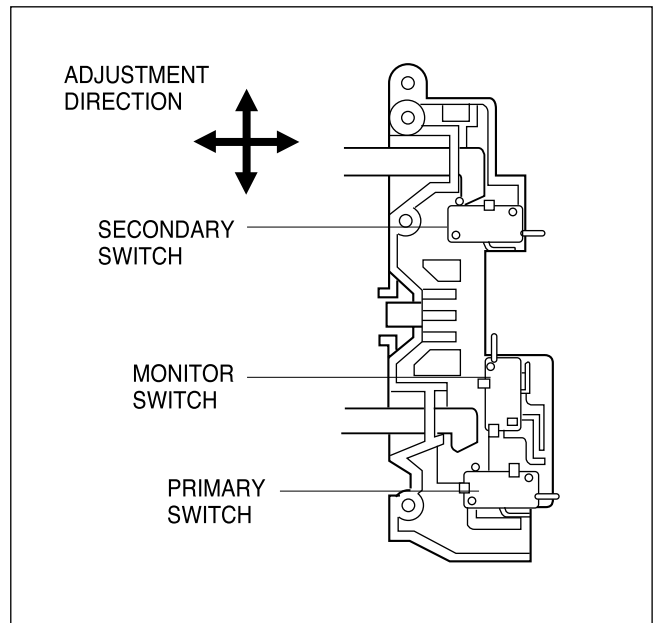

2) MOUNTING OF THE PRIMARY/MONITOR/SECONDARY SWITCHES TO THE LATCH BOARD

3) INSTALLATION AND ADJUSTMENT OF THE LATCH BOARD TO THE OVEN ASSEMBLY

- Mount the latch board to the oven assembly.
- Adjust the latch board in the arrow direction so that oven door will not have any play in it when the door is closed.
- Tighten the mounting screw.
- **Check for play in the door by pushing the door release button. Door movement should be less than 0.5 mm. (1/64 inch)**

Don't push the door release button while making this adjustment. Make sure that the latch moves smoothly after adjustment is completed and that the screws are tight. Make sure the primary, monitor, and secondary switches operate properly by following the continuity test procedure.

INTERLOCK CONTINUITY TEST

WARNING : FOR CONTINUED PROTECTION AGAINST EXCESSIVE RADIATION EMISSION, REPLACE ONLY WITH IDENTICAL REPLACEMENT PARTS.

TYPE NO. SZM-V 16-FA-63 OR VP-533A-OF OR V-5230Q FOR PRIMARY SWITCH
 TYPE NO. SZM-V 16-FA-62 OR VP-532A-OF OR V-5220Q FOR MONITOR SWITCH
 TYPE NO. SZM-V 16-FA-63 OR VP-533A-OF OR V-5230Q FOR SECONDARY SWITCH

A. PRIMARY INTERLOCK SWITCH TEST

When the door release button is depressed slowly with the door closed, an audible **click** should be heard at the same time or successively at intervals. When the button is released slowly, the latches should activate the switches with an audible **click**.

If the latches do not activate the switches when the door is closed, the switches should be adjusted in accordance with the adjustment procedure. Disconnect the wire lead from the primary switch. Connect the ohmmeter leads to the common (COM) and normally open (NO) terminal of the switch. The meter should indicate an open circuit in the door open condition. When the door is closed, the meter should indicate a closed circuit.

When the primary switch operation is abnormal, make the necessary adjustment or replace the switch only with the same type of switch.

B. SECONDARY INTERLOCK SWITCH TEST







Disconnect the wire lead from the secondary switch.

Connect the ohmmeter leads to the common (COM) and normally open (NO) terminals of the switch. The meter should indicate a open circuit in the door open condition. When the door is closed, meter should indicate an closed circuit. When the secondary switch operation is abnormal, make the necessary adjustment or replace the switch only with the same type of switch.

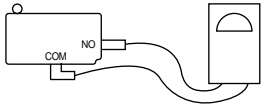
C. MONITOR SWITCH TEST

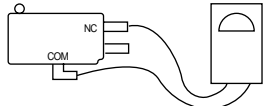
Disconnect the wire lead from the monitor switch. Connect the ohmmeter leads to the common (COM) and normally closed (NC) terminals of the switch. The meter should indicate closed circuit in the door open condition. When the door is closed, meter should indicate an open circuit. When the monitor switch operation is abnormal, replace with the same type of switch.

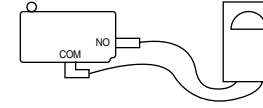
NOTE: After repairing the door or the interlock system, it is necessary to do this continuity test before operating the oven.

COMPONENTS	TEST PROCEDURE	RESULTS	
		Door open	Door closed
SWITCHES (Wire leads removed)	Check for continuity of the switch with an Ohm-meter		
	Primary Switch 		
	Monitor Switch 		
	Secondary Switch 		
NOTE : After checking for the continuity of switches, make sure that they are connected correctly.			



COMPONENT TEST PROCEDURE

CAUTIONS

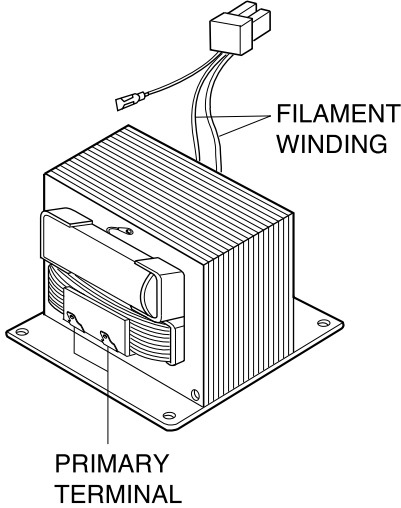
1. DISCONNECT THE POWER SUPPLY CORD FROM THE OUTLET WHENEVER REMOVING THE OUTER CASE FROM THE UNIT. PROCEED WITH THE TEST ONLY AFTER DISCHARGING THE HIGH VOLTAGE CAPACITOR AND REMOVING THE WIRE LEADS FROM THE PRIMARY WINDING OF THE HIGH VOLTAGE TRANSFORMER. (SEE PAGE 2-1)
2. ALL OPERATIONAL CHECKS WITH MICROWAVE ENERGY MUST BE DONE WITH A LOAD (1 LITER OF WATER IN CONTAINER) IN THE OVEN.

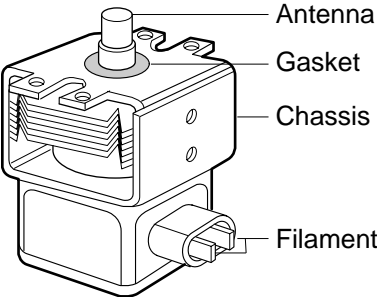
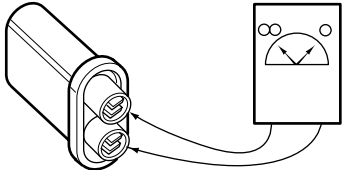
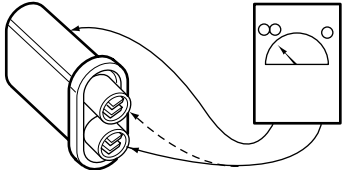
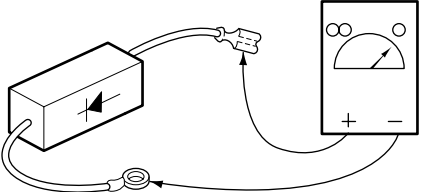
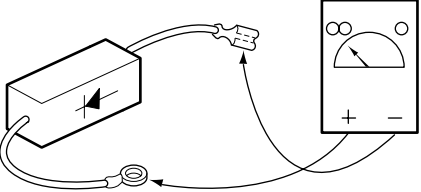
COMPONENTS	TEST PROCEDURE	RESULTS
<p>HIGH VOLTAGE TRANSFORMER (Wire leads removed)</p>	 <p>The diagram shows a high voltage transformer with a filament winding on top and primary terminals on the front. Labels point to the 'FILAMENT WINDING' and 'PRIMARY TERMINAL'.</p> <ol style="list-style-type: none"> 1. Measure the resistance. (Ohm-meter scale: Rx1 and Rx100) <ul style="list-style-type: none"> • Primary winding • Secondary winding • Filament winding 2. Measure the resistance. (Ohm-meter scale: Rx1000) <ul style="list-style-type: none"> • Primary winding to ground • Filament winding to ground 	<p>Approx.: 0.2 ~ 0.4 ohm Approx.: 70 ~ 100 ohm Less than: 1 ohm</p> <p>Normal: Infinite Normal: Infinite</p>
<p>MAGNETRON (Wire leads removed)</p>	<ol style="list-style-type: none"> 1. Measure the resistance. (Ohm-meter scale: Rx1) <ul style="list-style-type: none"> • Filament terminal 2. Measure the resistance. (Ohm-meter scale: Rx1000) <ul style="list-style-type: none"> • Filament to chassis 	<p>Normal: Less than 1 ohm</p> <p>Normal: Infinite</p>

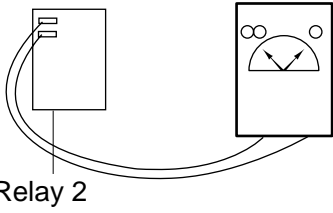
COMPONENTS	TEST PROCEDURE	RESULTS
	 <p>NOTE: When testing the magnetron, be sure to install the magnetron gasket in the correct position and be sure that the gasket is in good condition.</p>	
HIGH VOLTAGE CAPACITOR	<p>Measure the resistance. (Ohm-meter scale: Rx1000) • Terminal to terminal.</p> 	Normal: Momentarily indicates several ohms, and then gradually returns to infinite.
	<p>Measure the resistance. (Ohm-meter scale: Rx1000) • Terminal to case.</p> 	Normal: Infinite.
HIGH VOLTAGE DIODE	<p>Measure the continuity (Forward). (Ohm-meter scale: Rx10000)</p> 	Normal: Continuity. Abnormal: Infinite.
NOTE : Some inexpensive meters may indicate infinite resistance in both direction.	<p>Measure the continuity (Reverse). (Ohm-meter scale: Rx10000)</p> 	Normal: Infinite. Abnormal: Continuity.

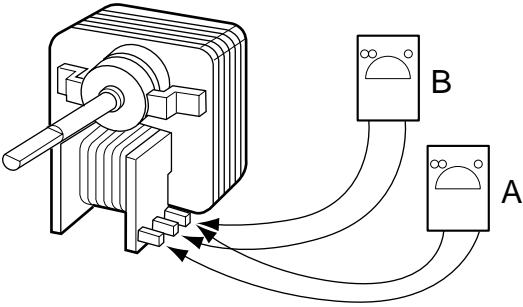
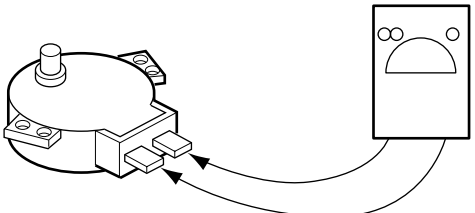
COMPONENTS	TEST PROCEDURE	RESULTS		
RELAY 2	<p>Check for continuity of relay 2 with an ohm-meter. (Remove wire leads from relay 2 and operate the unit.)</p>  <p>Relay 2</p>	POWER LEVEL		
FAN MOTOR (Wire leads removed)	<p>Measure the resistance. (Ohm-meter scale: R x 1)</p> 	<p>Normal: A: Approx. 85 ~ 100 ohm. B: Approx. 10 ~ 25 ohm.</p> <p>Abnormal: Infinite or several ohm.</p>		
TURNTABLE MOTOR (Wire leads removed)	<p>Measure the resistance. (Ohm-meter scale: R x 1)</p> 	<p>Normal: Approx. 100~150 ohm Abnormal: Infinite or several ohm.</p>		
<p>NOTE : • A MICROWAVE LEAKAGE TEST MUST ALWAYS BE PERFORMED WHEN THE UNIT IS SERVICED FOR ANY REASON. • MAKE SURE THE WIRE LEADS ARE IN THE CORRECT POSITION. • WHEN REMOVING THE WIRE LEADS FROM THE PARTS, BE SURE TO GRASP THE CONNECTOR, NOT THE WIRES.</p>				

TROUBLE SHOOTING

WHEN YOU GET A COMPLAINT FROM YOUR CUSTOMER, EVALUATE THE COMPLAINT CAREFULLY. IF THE FOLLOWING SYMPTOMS APPLY, PLEASE INSTRUCT THE CUSTOMER IN THE PROPER USE OF THE MICROWAVE OVEN. THIS CAN ELIMINATE AN UNNECESSARY SERVICE CALL.

CAUTIONS

1. Check grounding before checking for trouble.
 2. Be careful of the high voltage circuit.
 3. Discharge the high voltage capacitor. (See page 2-1)
 4. When checking the continuity of the switches or of the high voltage transformer, disconnect one lead wire from these parts and then check continuity with the AC plug removed. To do otherwise may result in a false reading or damage to your meter.
 5. Do not touch any part of the circuit on the PCB since static electric discharge may damage this control panel.
- Always touch yourself to ground while working on this panel to discharge any static charge built up in your body. (Micom model only)

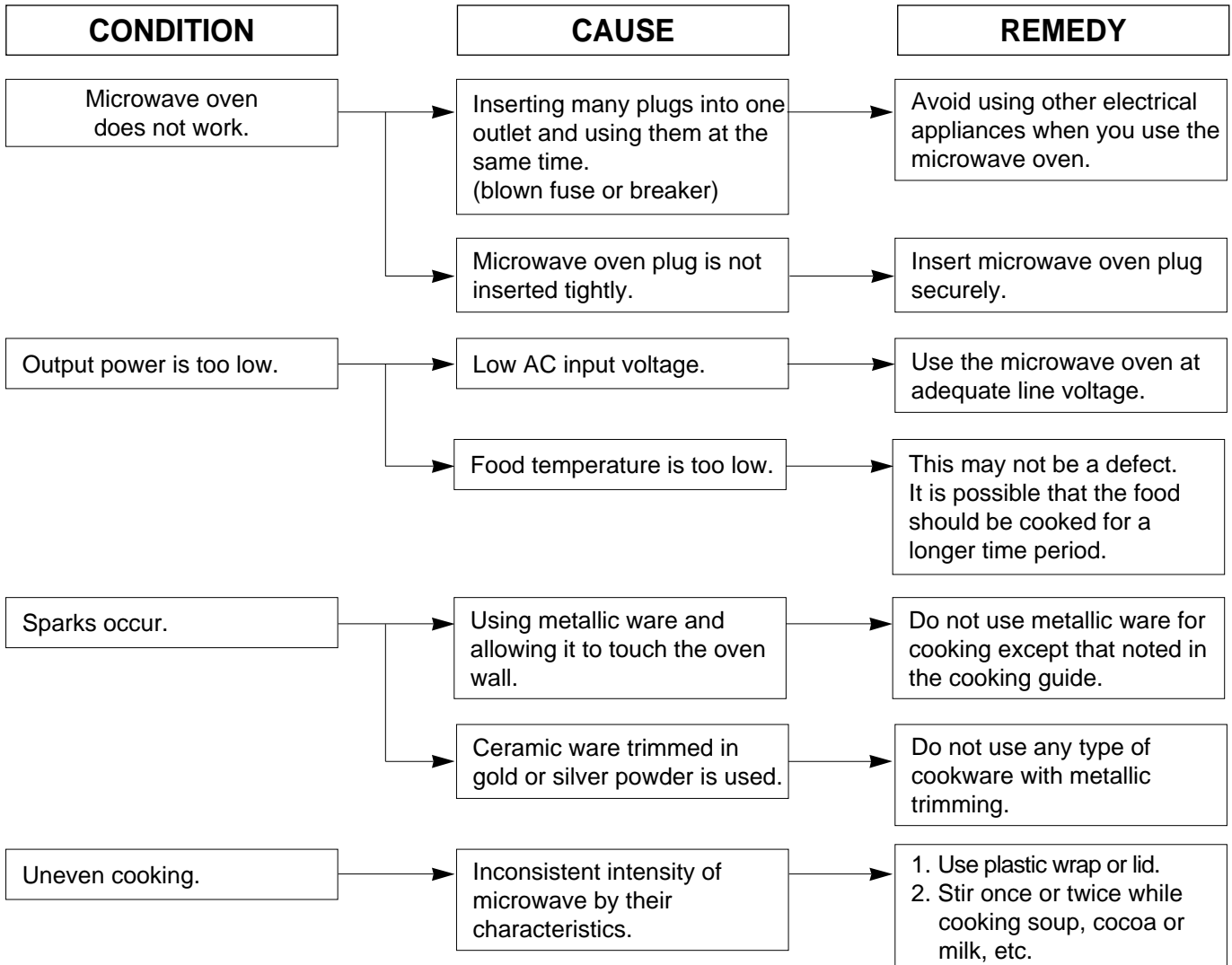

(TROUBLE 1) The following visual conditions indicate a probable defective control circuit.

1. Incomplete segments.
 - Segment missing.
 - Partial segment missing.
 - Digit flickering (NOTE: Slight flickering is normal.)
2. Colon does not turn on or blink.
3. A distinct change in the brightness of one or more numbers in display.
4. One or more digits in the display are not lighting.
5. Display indicates a number different from one touched, for example, key in **5** and **3** appears in the display.
6. Specific numbers (for example 7 or 9) will not display when key pad is touched.
7. Display does not count down with time blinking or up with clock operation.
8. Display obviously jumps in time while counting down.
9. Display counts down too fast while cooking.
10. Each indicator light does not turn on after setting cooking cycle.
11. Display time of day does not reappear when cooking is finished.

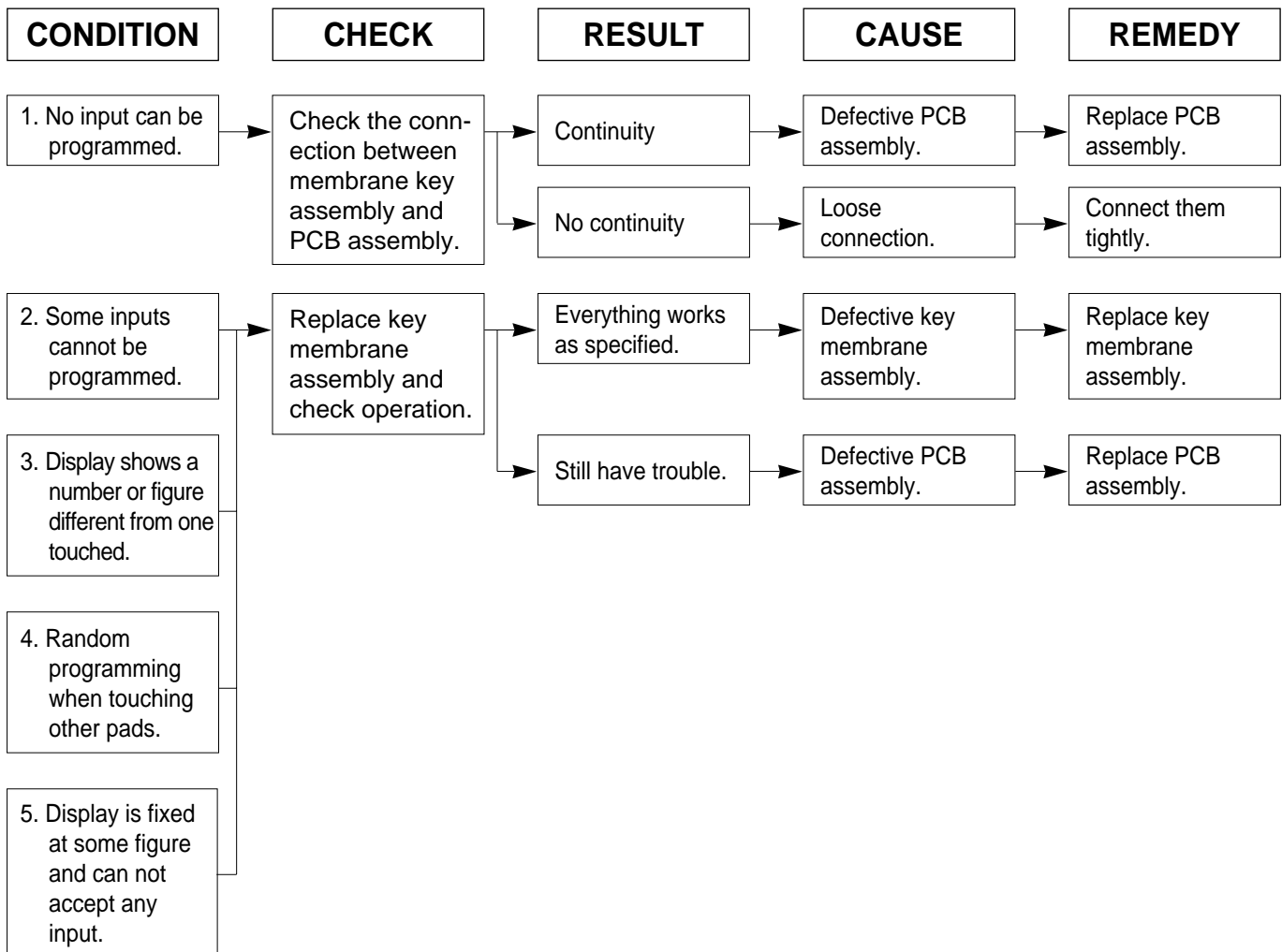

(TROUBLE 2) Oven does not operate at all, Display window does not display any figures, and no input is accepted.

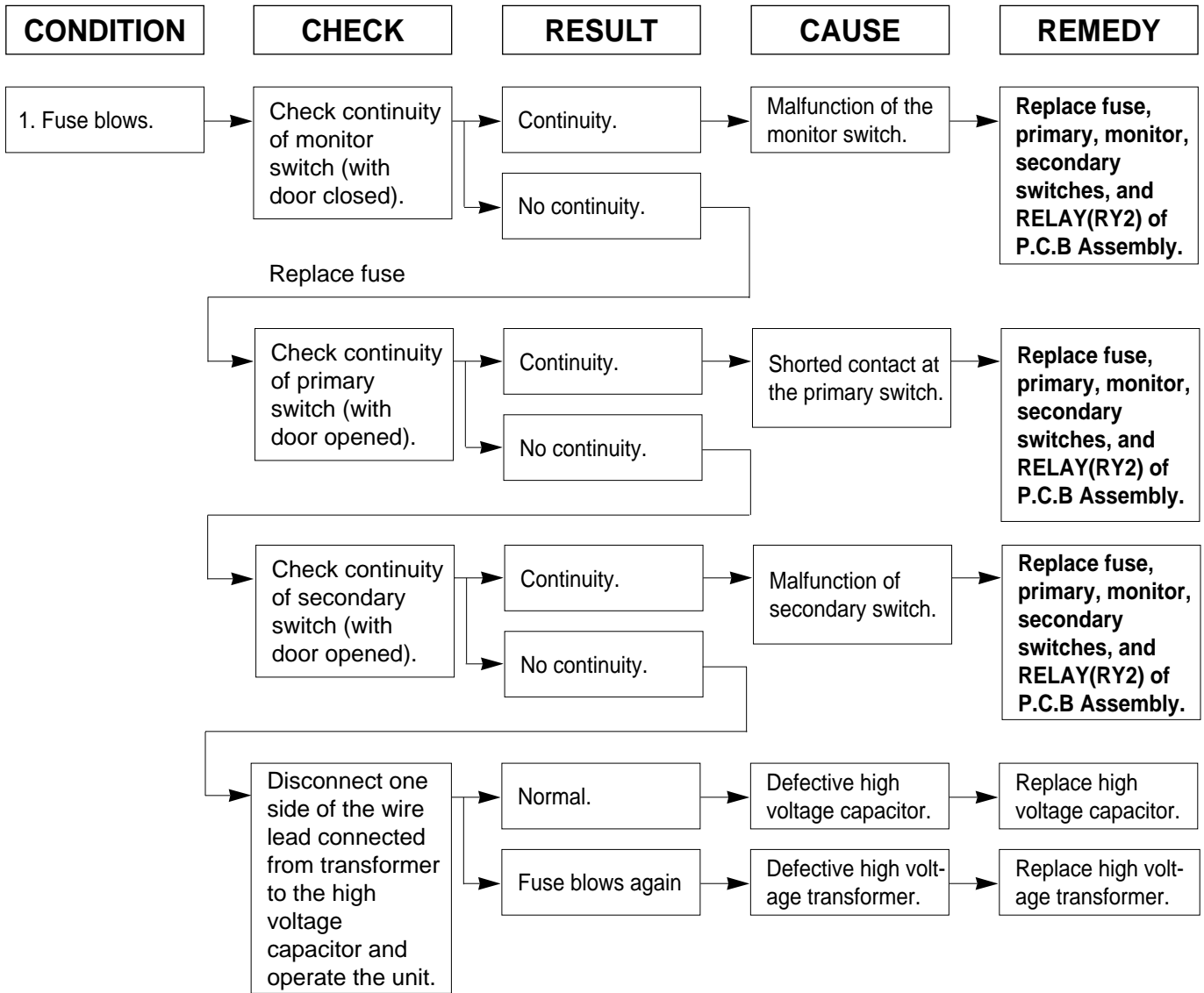

NOTE : All these switches must be replaced at the same time. Refer to page 5-7, 5-8

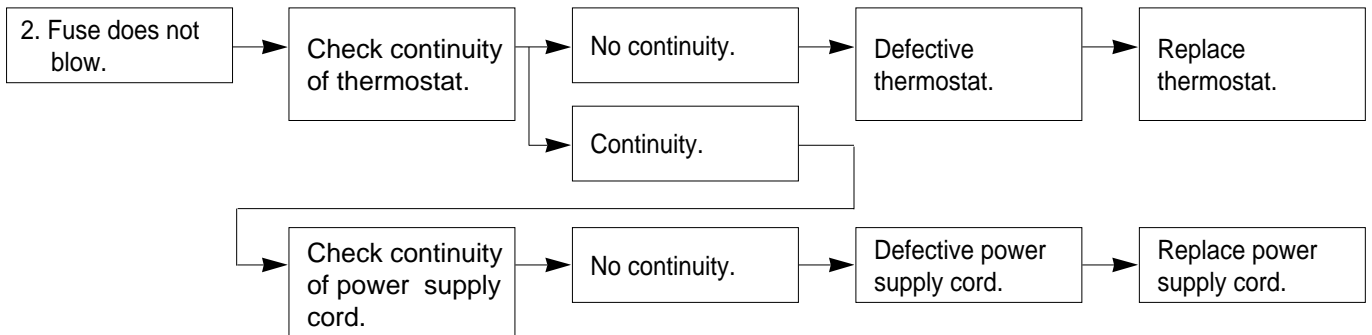

(TROUBLE 3) Display shows all figures set, but oven does not start cooking while desired program times are set and START pad is touched.

CONDITION	CHECK	RESULT	CAUSE	REMEDY
1. Setting time does not count down when touching START pad.	Check continuity of secondary switch (with door closed).	No continuity.	Defective secondary switch.	Replace secondary switch.
		Continuity.		
	Check the connection between CN1 connector and PCB assembly.	Continuity	Defective PCB assembly.	Replace PCB assembly.
		No continuity	Loose connection.	Connect them tightly.
2. Fan motor or oven lamp do not turn on.	Check fan motor.	Abnormal	Defective fan motor.	Replace fan motor.
	Check oven lamp.	Abnormal	Defective oven lamp.	Replace oven lamp.
		Normal		

(TROUBLE 4) Oven seems to be operating but little heat is produced in oven load.

CONDITION	CHECK	RESULT	CAUSE	REMEDY
Output is low	Check the power source voltage.	Lower than 90% of rating voltage.	Decrease in power source voltage with load.	Suggest customer contact local electric power utility co. or qualified electrician.
		Normal		
	Disconnect the wire leads from relay 2 and check on and off time with multimeter.	Abnormal	Defective PCB assembly.	Replace PCB assembly.
	Normal			
	Measure the output power.	Abnormal	Defective magnetron.	Replace magnetron.

NOTE : Simple test of power output-conducted by heating one liter water for one min. if available. Minimum 8.5°C temperature rise is normal condition.

**(TROUBLE 5) No microwave oscillation even though oven lamp and fan motor run.
(Display operates properly)**

CONDITION	CHECK	RESULT	CAUSE	REMEDY
No microwave oscillation.	Disconnect the wire leads from relay 2 and check continuity of relay 2. (Operate the unit)	No continuity.	Defective PCB assembly.	Replace PCB assembly.
		Continuity.		
	Check high voltage transformer	Abnormal	Defective high voltage transformer.	Replace high voltage transformer.
		Normal		
	Check high voltage capacitor.	Abnormal	Defective high voltage capacitor.	Replace high voltage capacitor.
		Normal		
	Check high voltage diode.	Abnormal	Defective high voltage diode.	Replace high voltage diode.
		Normal		
	Check magnetron.	Abnormal	Defective magnetron.	Replace magnetron.

NOTE : • Make sure the wire leads correct position.

- When Removing the wire leads from the parts, be sure to grasp the connector, not the wires.
- When removing the magnetron, be sure to install the magnetron gasket in the correct position and in good condition.

Output is full power when you set lower power level.	Disconnect the wire leads from relay 2 and check continuity relay 2. (Operate the unit)	Abnormal.	Defective PCB assembly.	Replace PCB assembly.
--	--	-----------	-------------------------	-----------------------

EXPLODED VIEW

INTRODUCTION

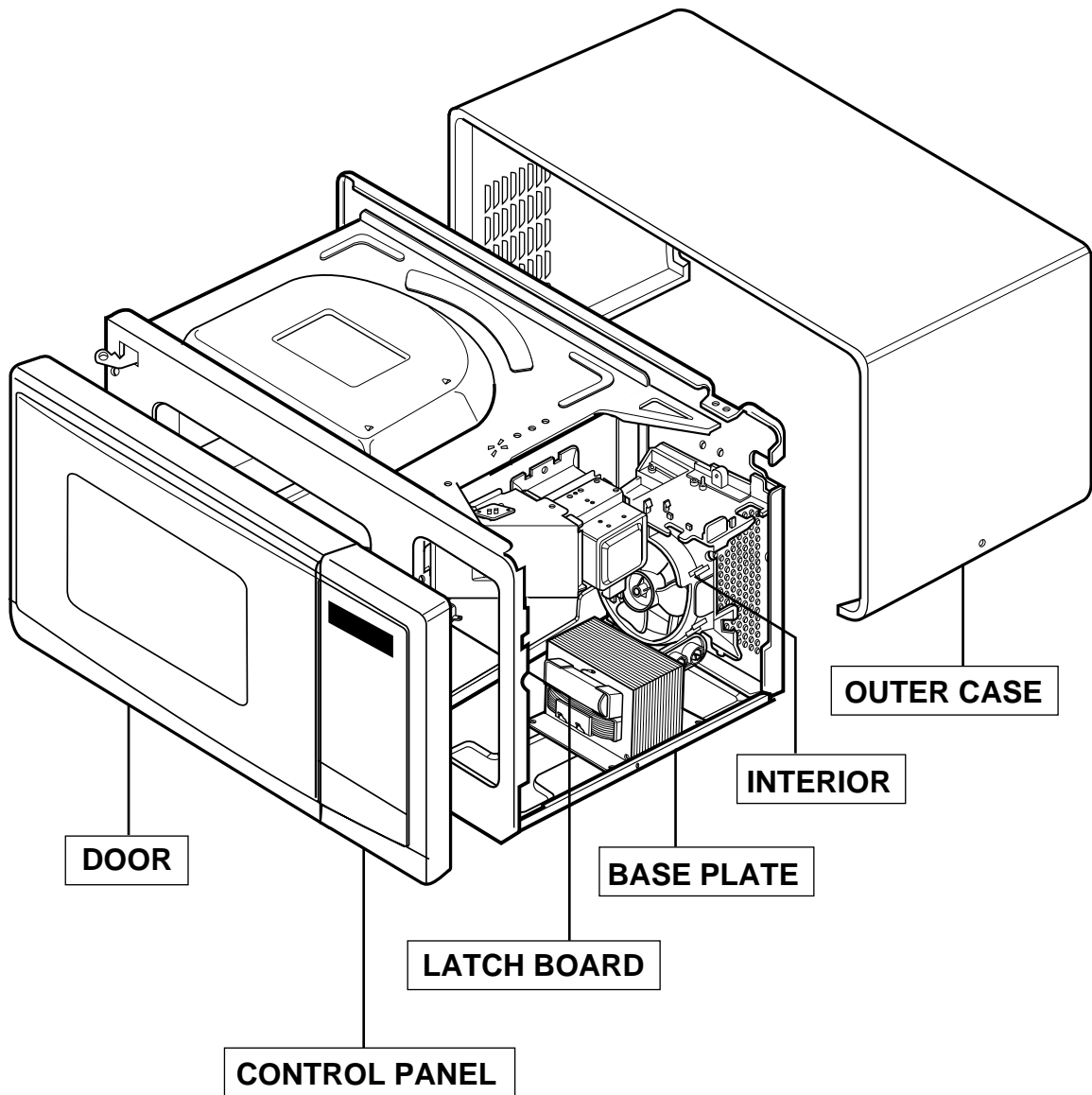

DOOR PARTS

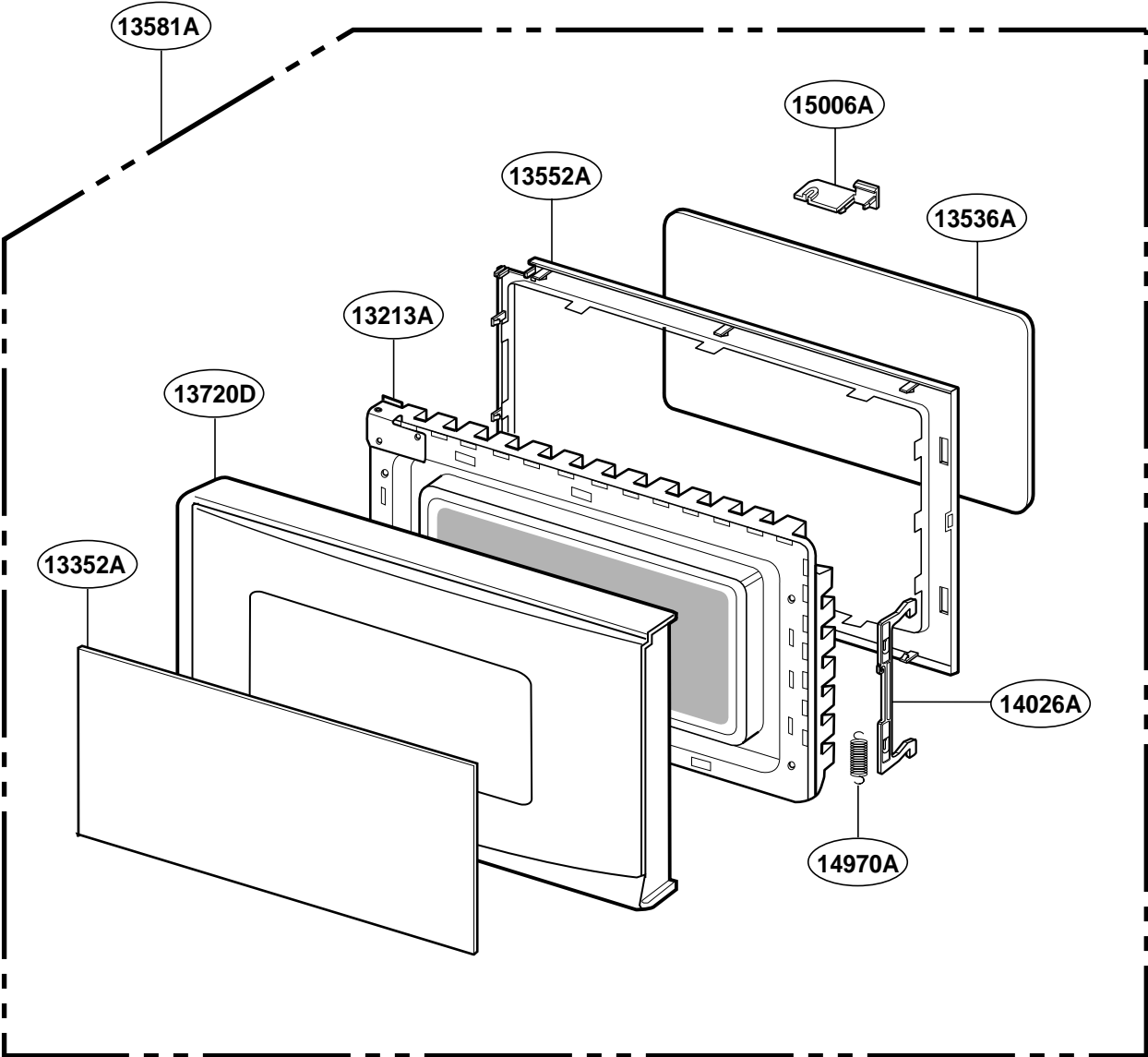

CONTROLLER PARTS

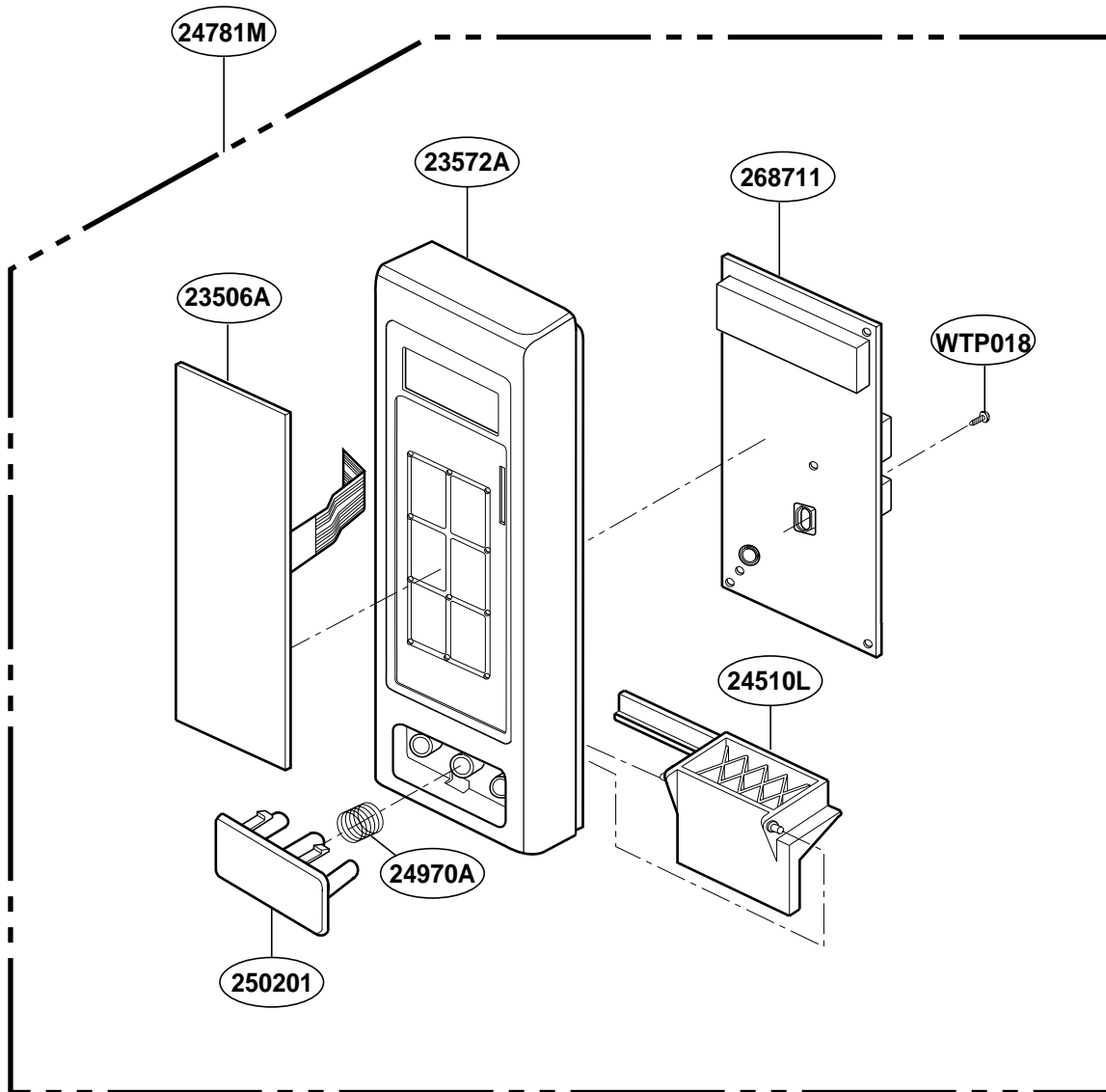

OVEN CAVITY PARTS

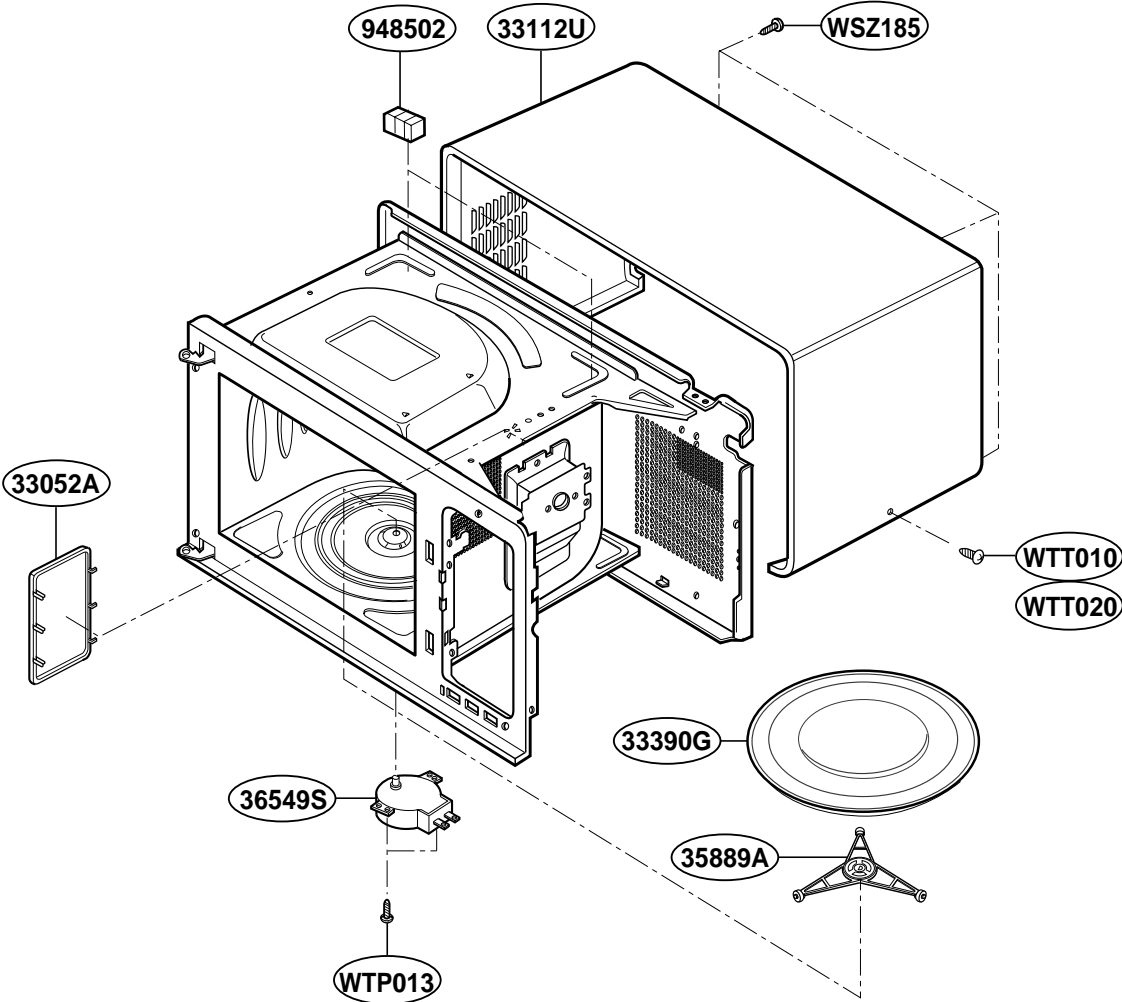

LATCH BOARD PARTS

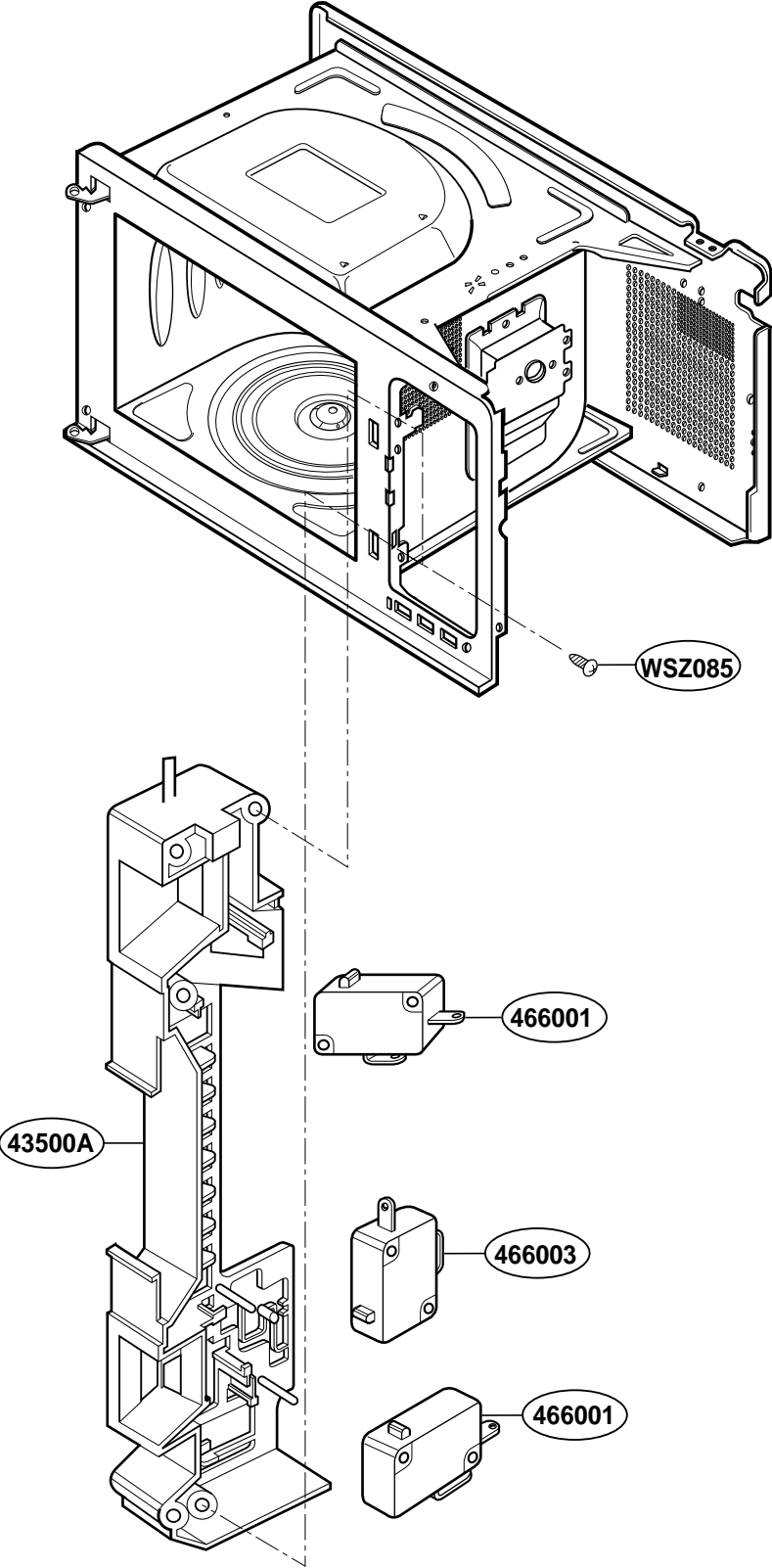

INTERIOR PARTS

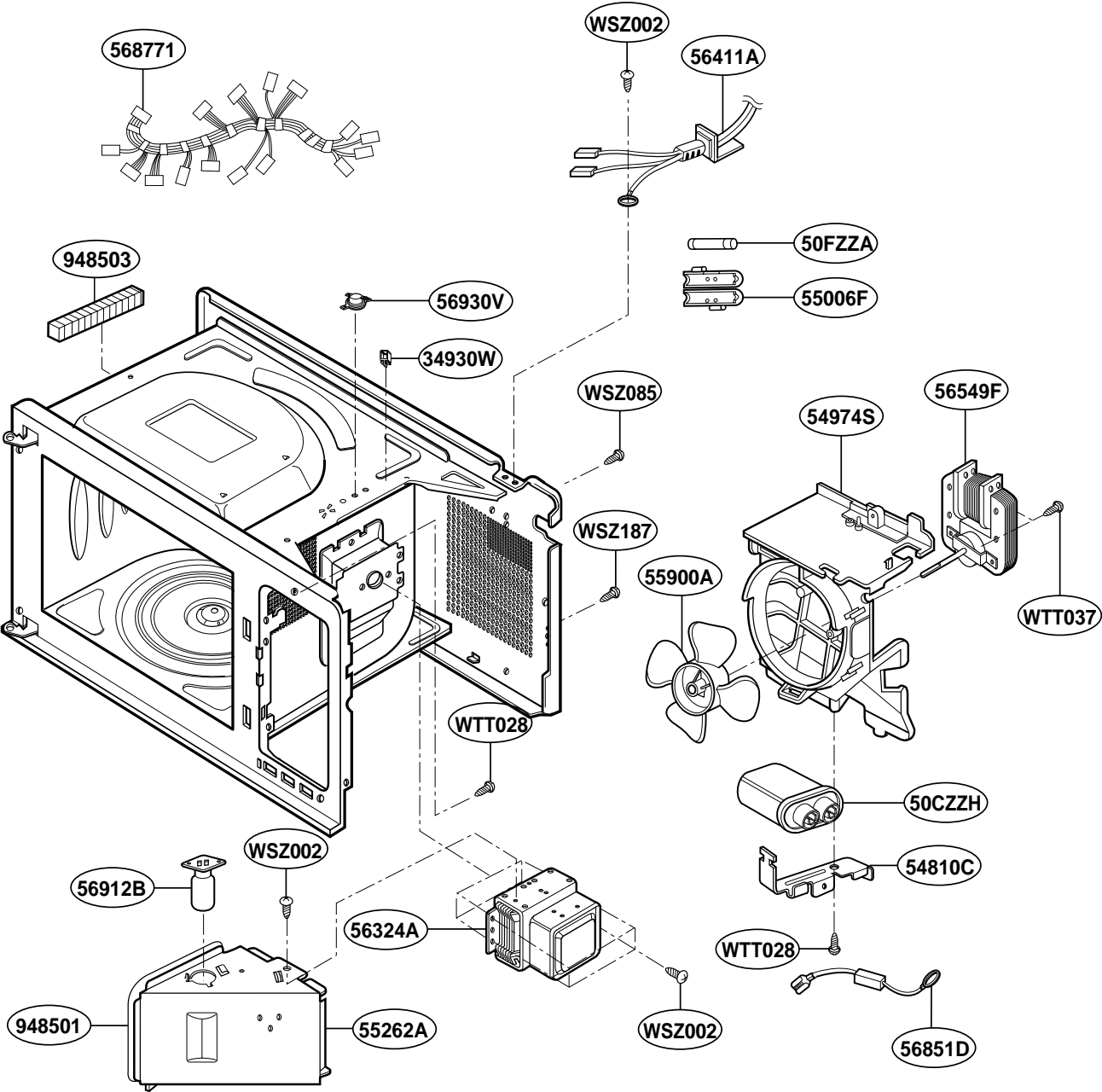

BASE PLATE PARTS

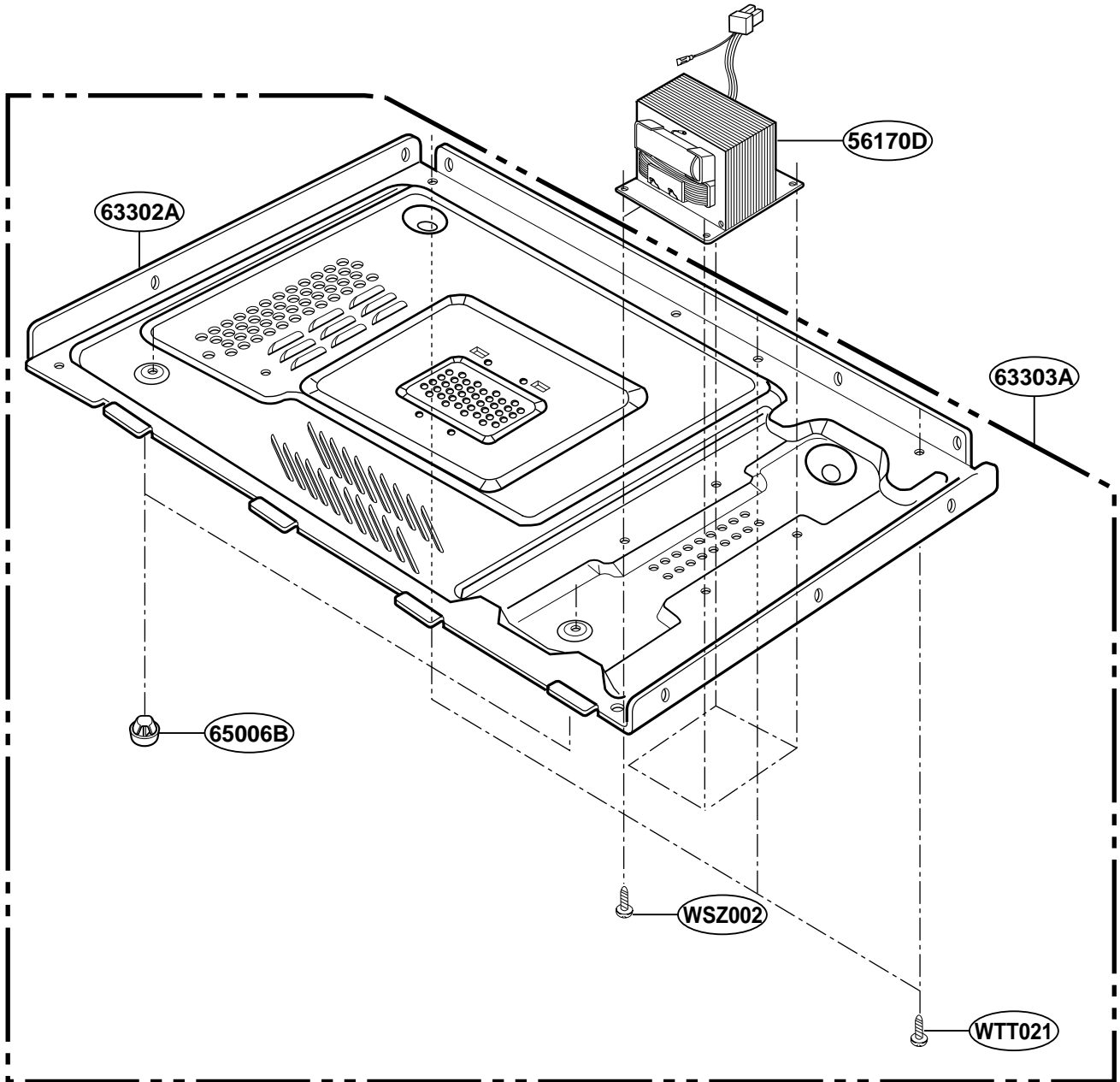

REPLACEMENT PARTS LIST

FOR MODEL: MS-1243AZ-KWHELGA

LOC. NO.	PART NO.	DESCRIPTION	SVC	ALTER
*01	3828W5A3158	MANUAL,OWNERS	R	
*02	3828W5S3026	MANUAL,SERVICE	R	
*10	3890W3Y583A	BOX,YELLOW	R	
13213A	3213W1A031Q	DOOR FRAME ASSEMBLY	R	
13352A	3352W1A143A	FRONT SCREEN	S	
13536A	3536W1A004A	SEAL TAPE	S	
13552A	3552W0A012A	CHOKE COVER	R	
13581A	3581W1A386A	DOOR ASSEMBLY	R	
13720D	3720W0D312A	PANEL,DOOR	R	
14026A	4026W2A016A	LATCH	R	
14970A	4970WRA001B	SPRING	R	
15006A	5006W3A012A	CAP,CHOKE COVER	R	
23506A	3506W1A438A	KEY MEMBRANE	R	
23572A	3720W0C143A	PANEL,CONTROL	R	
24510L	4510W3L003A	LEVER	R	
24781M	4781W1M334A	CONTROLLER ASSEMBLY,MICOM	R	
24970A	4B72023B	SPRING	R	
250201	5020W1A177A	BUTTON	B	
268711	6871W1S197A	PWB(PCB) ASSEMBLY,SUB	R	
33052A	3052W1A004A	CANOPY,RESIN	R	
33112U	3112W1U037B	OUT CASE,U-BENDING	R	
33390G	3390W1A012B	TRAY,GLASS	R	
34930W	4930W3B029A	HOLDER,WIRE	R	
35889A	5889W1A003B	ROTATING RING ASSEMBLY	R	
36549S	6549W1S011B	MOTOR(CIRC),SYNCHRONOUS	R	6549W1S015A
43500A	3500W1A018A	BOARD,LATCH	R	
466001	6600W1K003D	SWITCH,MICRO	R	6600W1K001D
466001	6600W1K003D	SWITCH,MICRO	R	6600W1K004C
466003	6600W1K003C	SWITCH,MICRO	R	6600W1K001C
466003	6600W1K003C	SWITCH,MICRO	R	6600W1K004B
50CZZH	0CZZW1H005A	CAPACITOR,DRAWING[HIGH VOLTAGE]	R	0CZZW1H004C
50FZZA	3B74133K	FUSE,DRAWING	R	3B74133H
54810C	4810W4C003B	BRACKET,CAPACITOR	R	
54974S	4974W0A008A	GUIDE,SUCTION	R	
55006F	5006WRA002D	CAP,FUSE	R	
55262A	5208W1A017A	DUCT	R	
55900A	5900W1A004A	FAN	R	
56170D	6170W1D023H	TRANSFORMER,HIGH VOLTAGE	R	6170W1D050M
56324A	6324W1A001B	MAGNETRON	R	
56411A	6411W1A002L	POWER CORD ASSEMBLY	R	6411W1A002H
56549F	6549W1F005B	MOTOR(CIRC),FAN	R	
56851D	6021W3B001N	CABLE ASSEMBLY	R	
568771	6877W1A474A	HARNESS	R	
56912B	6912W3B002L	LAMP,DRAWING	R	

R,S: SERVICE PARTS

FOR MODEL: MS-1243AZ-KWHELGA

LOC. NO.	PART NO.	DESCRIPTION	SVC	ALTER
56930V	6930W1A004A	THERMOSTAT	R	6930W1A001J
56930V	6930W1A004A	THERMOSTAT	R	6930WRT002F
63302A	3302W0A036B	BASE PLATE	R	
63303A	3303W0A019B	BASE PLATE ASSEMBLY	R	
65006B	5006W3A019A	CAP,BASE PLATE	R	
948501	3B72244T	CUSHION	R	
948502	3B72244C	CUSHION	R	
948503	3B72246B	CUSHION	R	
WSZ002	1SBF0402418	SCREW TAP TITE(S),BINDING HEAD	R	
WSZ085	4B70188C	SCREW,DRAWING	R	
WSZ185	1SZZW2A002A	SCREW,DRAWING	R	
WSZ187	1SZZW2A002B	SCREW,DRAWING	R	
WTP013	1TPL0402418	SCREW TAPPING,PAN HEAD	R	
WTP018	1TPL0402818	SCREW TAPPING,PAN HEAD	R	
WTT010	1TTG0402422	SCREW TAPPING,TRUSS HEAD	R	
WTT021	1TTL0402418	SCREW TAPPING,TRUSS HEAD	R	
WTT028	1TTL0402818	SCREW TAPPING,TRUSS HEAD	R	
WTT037	1TTL0403818	SCREW TAPPING,TRUSS HEAD	R	

R,S: SERVICE PARTS

FOR MODEL: MS-1243AZ-KBKELGA

LOC. NO.	PART NO.	DESCRIPTION	SVC	ALTER
*01	3828W5A3158	MANUAL,OWNERS	R	
*02	3828W5S3026	MANUAL,SERVICE	R	
*10	3890W3Y583A	BOX,YELLOW	R	
13213A	3213W1A031P	DOOR FRAME ASSEMBLY	R	
13352A	3352W1A143B	FRONT SCREEN	S	
13536A	3536W1A004A	SEAL TAPE	S	
13552A	3552W0A012A	CHOKE COVER	R	
13581A	3581W1A386B	DOOR ASSEMBLY	R	
13720D	3720W0D312B	PANEL,DOOR	R	
14026A	4026W2A016A	LATCH	R	
14970A	4970WRA001B	SPRING	R	
15006A	5006W3A012A	CAP,CHOKE COVER	R	
23506A	3506W1A438B	KEY MEMBRANE	R	
23572A	3720W0C143B	PANEL,CONTROL	R	
24510L	4510W3L003A	LEVER	R	
24781M	4781W1M334B	CONTROLLER ASSEMBLY,MICOM	R	
24970A	4B72023B	SPRING	R	
250201	5020W1A177B	BUTTON	B	
268711	6871W1S197A	PWB(PCB) ASSEMBLY,SUB	R	
33052A	3052W1A004A	CANOPY,RESIN	R	
33112U	3112W1U037C	OUT CASE,U-BENDING	R	
33390G	3390W1A012B	TRAY,GLASS	R	
34930W	4930W3B029A	HOLDER,WIRE	R	
35889A	5889W1A003B	ROTATING RING ASSEMBLY	R	
36549S	6549W1S011B	MOTOR(CIRC),SYNCHRONOUS	R	6549W1S015A
36549S	6549W1S011B	MOTOR(CIRC),SYNCHRONOUS	R	6549W1S017A
43500A	3500W1A018A	BOARD,LATCH	R	
466001	6600W1K003D	SWITCH,MICRO	R	6600W1K001D
466001	6600W1K003D	SWITCH,MICRO	R	6600W1K004C
466003	6600W1K003C	SWITCH,MICRO	R	6600W1K001C
466003	6600W1K003C	SWITCH,MICRO	R	6600W1K004B
50CZZH	0CZZW1H005A	CAPACITOR,DRAWING[HIGH VOLTAGE]	R	0CZZW1H004C
50FZZA	3B74133K	FUSE,DRAWING	R	3B74133H
54810C	4810W4C003B	BRACKET,CAPACITOR	R	
54974S	4974W0A008A	GUIDE,SUCTION	R	
55006F	5006WRA002D	CAP,FUSE	R	
55262A	5208W1A017A	DUCT	R	
55900A	5900W1A004A	FAN	R	
56170D	6170W1D023H	TRANSFORMER,HIGH VOLTAGE	R	6170W1D050M
56324A	6324W1A001B	MAGNETRON	R	
56411A	6411W1A002H	POWER CORD ASSEMBLY	R	
56549F	6549W1F005B	MOTOR(CIRC),FAN	R	
56851D	6021W3B001N	CABLE ASSEMBLY	R	
568771	6877W1A474A	HARNESS	R	

R,S: SERVICE PARTS

FOR MODEL: MS-1243AZ-KBKELGA

LOC. NO.	PART NO.	DESCRIPTION	SVC	ALTER
56912B	6912W3B002L	LAMP,DRAWING	R	
56930V	6930W1A004A	THERMOSTAT	R	6930W1A001J
56930V	6930W1A004A	THERMOSTAT	R	6930WRT002F
63302A	3302W0A036B	BASE PLATE	R	
63303A	3303W0A019B	BASE PLATE ASSEMBLY	R	
65006B	5006W3A019A	CAP,BASE PLATE	R	
948501	3B72244T	CUSHION	R	
948502	3B72244C	CUSHION	R	
948503	3B72246B	CUSHION	R	
WSZ002	1SBF0402418	SCREW TAP TITE(S),BINDING HEAD	R	
WSZ085	4B70188C	SCREW,DRAWING	R	
WSZ185	1SZZW2A002A	SCREW,DRAWING	R	
WSZ187	1SZZW2A002B	SCREW,DRAWING	R	
WTP013	1TPL0402418	SCREW TAPPING,PAN HEAD	R	
WTP018	1TPL0402818	SCREW TAPPING,PAN HEAD	R	
WTT021	1TTL0402418	SCREW TAPPING,TRUSS HEAD	R	
WTT028	1TTL0402818	SCREW TAPPING,TRUSS HEAD	R	
WTT037	1TTL0403818	SCREW TAPPING,TRUSS HEAD	R	

R,S: SERVICE PARTS

SCHEMATIC DIAGRAM OF P.C.B.

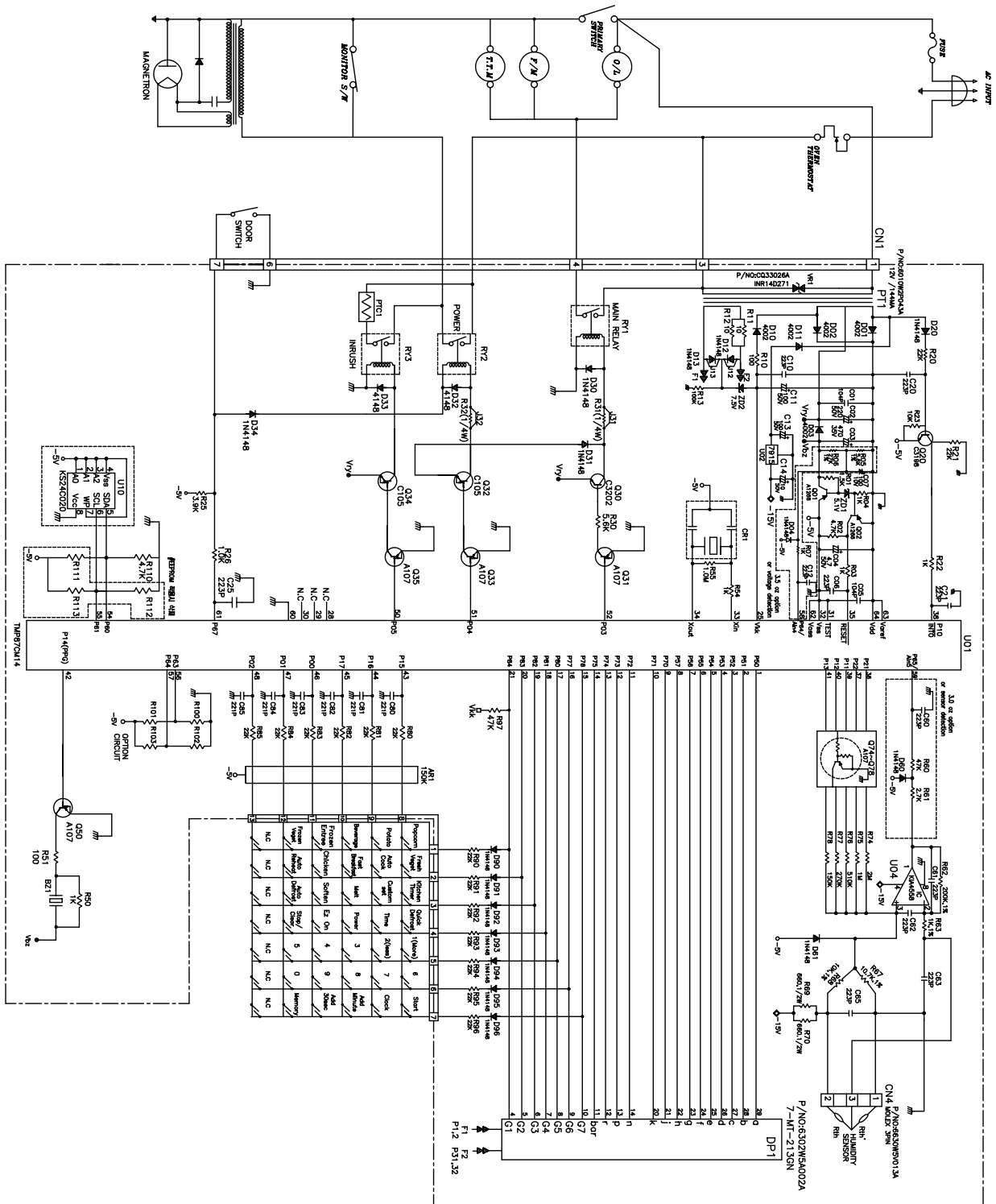

PRINTED CIRCUIT BOARD

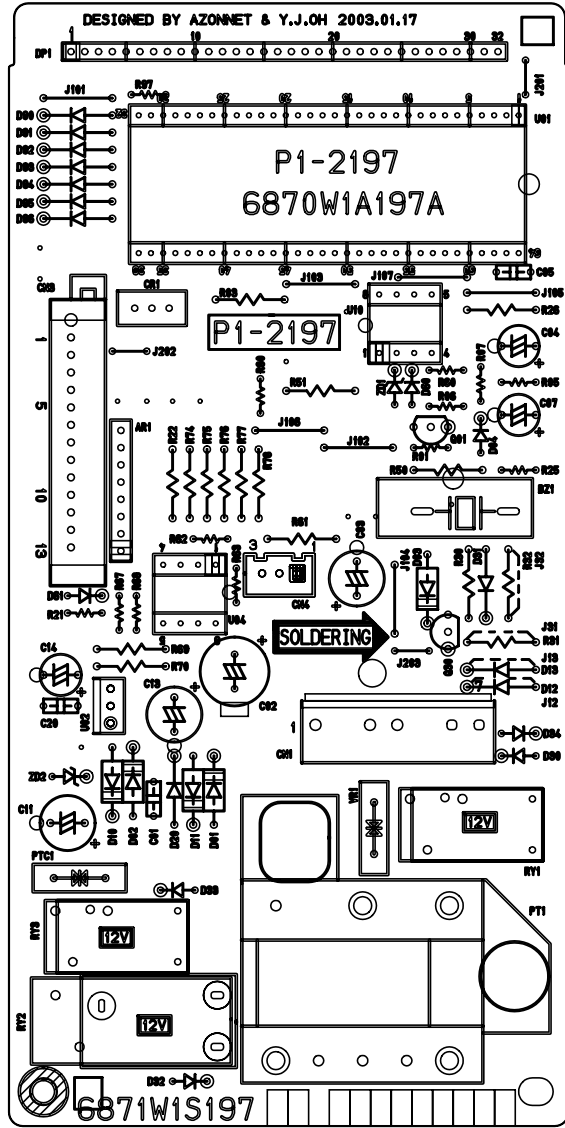
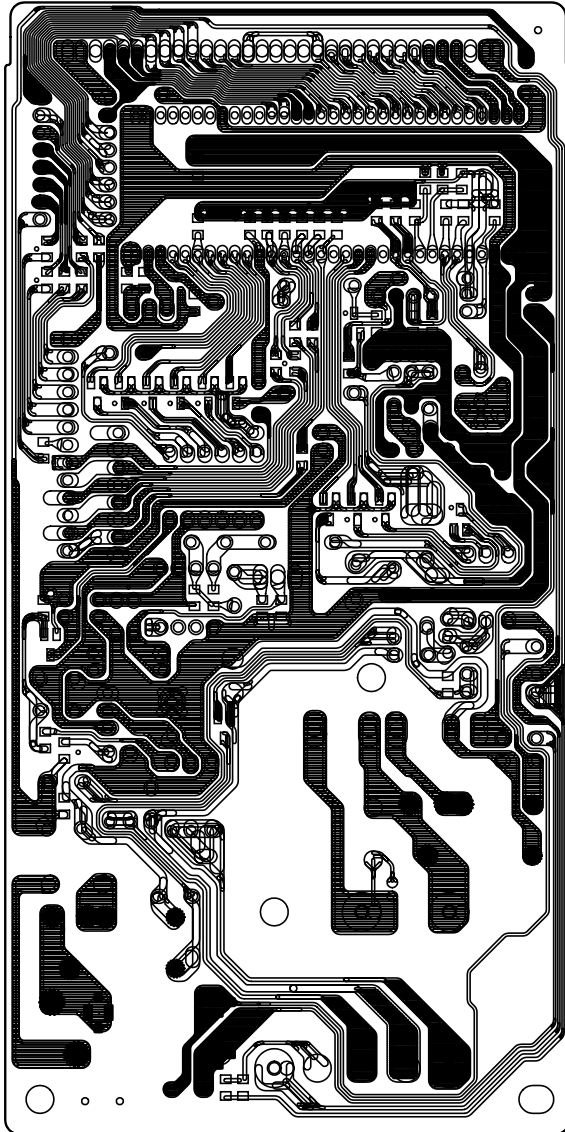

P.C.B. PARTS LIST

LOC. NO.	PART NO.	DESCRIPTION	SPEC	SVC	ALTER
AR1	0RZ1503G610	RESISTOR,DRAWING	150KOHM 1/4W 5% 3216 BULK 8 PIN	R	
BZ1	6908W3YA01B	BUZZER	TFM-57 CW NINGBO EAST PIEZO 2048HZ 70DB	R	6908W3YA01A
C01	0CK1040K949	CAPACITOR,FIXED CERAMIC(HIGH DIELECTRIC)	0.1UF D 50V 80%,-20% F(Y5V) TA52	R	
C02	0CE2276K618	CAPACITOR,FIXED ELECTROLYTIC	220UF SMS,SG 50V 20% FL TP 5	R	
C03	0CE4771J618	CAPACITOR,FIXED ELECTROLYTIC	470UF SM,SA 35V 20% FL TP 5	R	
C04	0CE1076D638	CAPACITOR,FIXED ELECTROLYTIC	100UF SMS,SG 10V 20% FM5 TP 5	R	
C05	0CK1040K949	CAPACITOR,FIXED CERAMIC(HIGH DIELECTRIC)	0.1UF D 50V 80%,-20% F(Y5V) TA52	R	
C06	0CH1223K566	CAPACITOR,FIXED CERAMIC(TEMP.COMPENSATE)	0.022UF 2012 50V 10% X7R R/TP	R	
C10	0CH1223K566	CAPACITOR,FIXED CERAMIC(TEMP.COMPENSATE)	0.022UF 2012 50V 10% X7R R/TP	R	
C11	0CE1076K638	CAPACITOR,FIXED ELECTROLYTIC	100UF SMS,SG 50V 20% FM5 TP 5	R	
C20	0CK2230K949	CAPACITOR,FIXED CERAMIC(HIGH DIELECTRIC)	22NF D 50V 80%,-20% F(Y5V) TA52	R	
C21	0CH1223K566	CAPACITOR,FIXED CERAMIC(TEMP.COMPENSATE)	0.022UF 2012 50V 10% X7R R/TP	R	
C25	0CH1223K566	CAPACITOR,FIXED CERAMIC(TEMP.COMPENSATE)	0.022UF 2012 50V 10% X7R R/TP	R	
C55	0CH1104K946	CAPACITOR,FIXED CERAMIC(TEMP.COMPENSATE)	0.1UF 2012 50V 80%,-20% Y5V(F) R/TP	R	
C80	0CH1221K566	CAPACITOR,FIXED CERAMIC(TEMP.COMPENSATE)	220PF 2012 50V 10% X7R R/TP	R	
C81	0CH1221K566	CAPACITOR,FIXED CERAMIC(TEMP.COMPENSATE)	220PF 2012 50V 10% X7R R/TP	R	
C82	0CH1221K566	CAPACITOR,FIXED CERAMIC(TEMP.COMPENSATE)	220PF 2012 50V 10% X7R R/TP	R	
C83	0CH1221K566	CAPACITOR,FIXED CERAMIC(TEMP.COMPENSATE)	220PF 2012 50V 10% X7R R/TP	R	
C84	0CH1221K566	CAPACITOR,FIXED CERAMIC(TEMP.COMPENSATE)	220PF 2012 50V 10% X7R R/TP	R	
CR1	6212W5YA03A	RESONATOR,CRYSTAL	GST8.0 MURATA 8MHZ +/-0.5% 15PF TP NONE	R	
CU1	4850W4C001A	CUSHION	3.5T 15W 40L RUBBER BLACK	R	
D01	0DD400209AD	DIODE	1N4002 PYUNG CHANG TP52 DO41 100V 1A 30A	R	
D02	0DD400209AD	DIODE	1N4002 PYUNG CHANG TP52 DO41 100V 1A 30A	R	
D03	0DD400209AD	DIODE	1N4002 PYUNG CHANG TP52 DO41 100V 1A 30A	R	
D04	0RD1002F609	RESISTOR,FIXED CARBON FILM	10K OHM 1/6 W 5% TA52	R	
D10	0DD400209AD	DIODE	1N4002 PYUNG CHANG TP52 DO41 100V 1A 30A	R	
D20	0DD414809AD	DIODE	1N4148 PYUNG CHANG TP52 DO35 100V 0.5A 0	R	
D30	0DD414809AE	DIODE	1N4148M PYUNG CHANG TP52 DO34 60V 0.5A 0	R	
D31	0DD414809AD	DIODE	1N4148 PYUNG CHANG TP52 DO35 100V 0.5A 0	R	
D32	0DD414809AE	DIODE	1N4148M PYUNG CHANG TP52 DO34 60V 0.5A 0	R	
D33	0DD414809AE	DIODE	1N4148M PYUNG CHANG TP52 DO34 60V 0.5A 0	R	
D34	0DD414809AE	DIODE	1N4148M PYUNG CHANG TP52 DO34 60V 0.5A 0	R	
D60	0RD1002F609	RESISTOR,FIXED CARBON FILM	10K OHM 1/6 W 5% TA52	R	
D90	0DD414809AD	DIODE	1N4148 PYUNG CHANG TP52 DO35 100V 0.5A 0	R	
D91	0DD414809AD	DIODE	1N4148 PYUNG CHANG TP52 DO35 100V 0.5A 0	R	
D92	0DD414809AD	DIODE	1N4148 PYUNG CHANG TP52 DO35 100V 0.5A 0	R	
D93	0DD414809AD	DIODE	1N4148 PYUNG CHANG TP52 DO35 100V 0.5A 0	R	
D94	0DD414809AD	DIODE	1N4148 PYUNG CHANG TP52 DO35 100V 0.5A 0	R	
D95	0DD414809AD	DIODE	1N4148 PYUNG CHANG TP52 DO35 100V 0.5A 0	R	
D96	0DD414809AD	DIODE	1N4148 PYUNG CHANG TP52 DO35 100V 0.5A 0	R	
DP1	6302W5A002D	DIGITRON	VFD25-0709 ZEC 7 MS-117YT 7 SCROLL	R	6302W5A002A
PT1	6010W2P043P	TRANSFORMER,POWER	120V 60HZ DC 12V / AC 3.4V LGETA LEADER(R	6010W2P043A
PTC1	6322W5A007A	THERMISTOR,NTC	MMT-0.1CD-SP2388 SINGI INDUSTRY 100KOHM	R	
Q01	0TR126609AA	TRANSISTOR,BIPOLARS	KTA1266-Y(KTA1015) KEC TP TO92 50V 150MA	R	
Q02	0TR150509AC	TRANSISTOR,BIPOLARS	KTA1505-Y-T1(AZY) KEC TP TO92 50V 100MA	R	
Q20	0TR387509AB	TRANSISTOR,BIPOLARS	KTC3875S-Y-T1(ALY) KEC TP TO92 50V 150M	R	
Q30	0TR320209BA	TRANSISTOR,BIPOLARS	KEC KTC3202-O TP TO92 50V 150MA	R	
Q31	0TR107009AC	TRANSISTOR,BIPOLARS	KRA107S-T1 KEC TP TO92 50V 100MA	R	
Q32	0TR105008CA	TRANSISTOR,BIPOLARS	KRC105S KEC R/TP SOT23 50V 100MA	R	
Q33	0TR107009AC	TRANSISTOR,BIPOLARS	KRA107S-T1 KEC TP TO92 50V 100MA	R	

R:SERVICE PARTS

LOC. NO.	PART NO.	DESCRIPTION	SPEC	SVC	ALTER
Q34	0TR105008CA	TRANSISTOR,BIPOLARS	KRC105S KEC R/TP SOT23 50V 100MA	R	
Q35	0TR107009AC	TRANSISTOR,BIPOLARS	KRA107S-T1 KEC TP TO92 50V 100MA	R	
Q50	0TR107009AC	TRANSISTOR,BIPOLARS	KRA107S-T1 KEC TP TO92 50V 100MA	R	
R01	0RD1501F609	RESISTOR,FIXED CARBON FILM	1.5K OHM 1/6 W 5% TA52	R	
R02	0RH4701L622	RESISTOR,METAL GLAZED(CHIP)	4.7K OHM 1/8 W 5% 2012 R/TP	R	
R03	0RD1001G609	RESISTOR,FIXED CARBON FILM	1K OHM 1/4 W 5% TA52	R	
R04	0RH1001L622	RESISTOR,METAL GLAZED(CHIP)	1K OHM 1/8 W 5% 2012 R/TP	R	
R10	0RH1000L622	RESISTOR,METAL GLAZED(CHIP)	100 OHM 1 / 8 W 5% 2012 R/TP	R	
R101	0RH1002L622	RESISTOR,METAL GLAZED(CHIP)	10KOHM 1/8 W 5% 2012 R/TP	R	
R103	0RH1002L622	RESISTOR,METAL GLAZED(CHIP)	10KOHM 1/8 W 5% 2012 R/TP	R	
R11	0RJ0102E672	RESISTOR,METAL GLAZED(CHIP)	10 OHM 1/8 W 5% 2012 R/TP	R	
R110	0RH4701L622	RESISTOR,METAL GLAZED(CHIP)	4.7K OHM 1/8 W 5% 2012 R/TP	R	
R12	0RJ0102E672	RESISTOR,METAL GLAZED(CHIP)	10 OHM 1/8 W 5% 2012 R/TP	R	
R13	0RH1003L622	RESISTOR,METAL GLAZED(CHIP)	100K OHM 1 / 8 W 2012 5.00% D	R	
R20	0RH2202L622	RESISTOR,METAL GLAZED(CHIP)	22K OHM 1/8 W 5% 2012 R/TP	R	
R21	0RD2202F609	RESISTOR,FIXED CARBON FILM	22K OHM 1/6 W 5% TA52	R	
R22	0RD1001G609	RESISTOR,FIXED CARBON FILM	1K OHM 1/4 W 5% TA52	R	
R23	0RH1002L622	RESISTOR,METAL GLAZED(CHIP)	10KOHM 1/8 W 5% 2012 R/TP	R	
R25	0RD3901F609	RESISTOR,FIXED CARBON FILM	3.9K OHM 1/6 W 5% TA52	R	
R26	0RD1001G609	RESISTOR,FIXED CARBON FILM	1K OHM 1/4 W 5% TA52	R	
R30	0RD5601G609	RESISTOR,FIXED CARBON FILM	5.6K OHM 1/4 W 5% TA52	R	
R50	0RD1001G609	RESISTOR,FIXED CARBON FILM	1K OHM 1/4 W 5% TA52	R	
R51	0RD1000G609	RESISTOR,FIXED CARBON FILM	100 OHM 1/4 W 5% TA52	R	
R54	0RH1001L622	RESISTOR,METAL GLAZED(CHIP)	1K OHM 1/8 W 5% 2012 R/TP	R	
R55	0RH1004L622	RESISTOR,METAL GLAZED(CHIP)	1MOHM 1/8 W 5% 2012 R/TP	R	
R80	0RD2202F609	RESISTOR,FIXED CARBON FILM	22K OHM 1/6 W 5% TA52	R	
R81	0RH2202L622	RESISTOR,METAL GLAZED(CHIP)	22K OHM 1/8 W 5% 2012 R/TP	R	
R82	0RH2202L622	RESISTOR,METAL GLAZED(CHIP)	22K OHM 1/8 W 5% 2012 R/TP	R	
R83	0RH2202L622	RESISTOR,METAL GLAZED(CHIP)	22K OHM 1/8 W 5% 2012 R/TP	R	
R84	0RH2202L622	RESISTOR,METAL GLAZED(CHIP)	22K OHM 1/8 W 5% 2012 R/TP	R	
R85	0RH2202L622	RESISTOR,METAL GLAZED(CHIP)	22K OHM 1/8 W 5% 2012 R/TP	R	
R90	0RH2202L622	RESISTOR,METAL GLAZED(CHIP)	22K OHM 1/8 W 5% 2012 R/TP	R	
R91	0RH2202L622	RESISTOR,METAL GLAZED(CHIP)	22K OHM 1/8 W 5% 2012 R/TP	R	
R92	0RH2202L622	RESISTOR,METAL GLAZED(CHIP)	22K OHM 1/8 W 5% 2012 R/TP	R	
R93	0RH2202L622	RESISTOR,METAL GLAZED(CHIP)	22K OHM 1/8 W 5% 2012 R/TP	R	
R94	0RH2202L622	RESISTOR,METAL GLAZED(CHIP)	22K OHM 1/8 W 5% 2012 R/TP	R	
R95	0RH2202L622	RESISTOR,METAL GLAZED(CHIP)	22K OHM 1/8 W 5% 2012 R/TP	R	
R96	0RH2202L622	RESISTOR,METAL GLAZED(CHIP)	22K OHM 1/8 W 5% 2012 R/TP	R	
R97	0RD4702F609	RESISTOR,FIXED CARBON FILM	47K OHM 1/6 W 5% TA52	R	
RY1	6920W2D010A	RELAY	OJ-SS-112LM OEG 250VAC 3A 12VDC 1A NO VE	R	6920WRD008A
RY1	6920W2D010A	RELAY	OJ-SS-112LM OEG 250VAC 3A 12VDC 1A NO VE	R	6920W2D010B
RY2	6920W5A009A	RELAY	OMIF-S-112LM ORIGINAL 250VAC 17A 12VDC 1	R	
RY3	6920W2D010A	RELAY	OJ-SS-112LM OEG 250VAC 3A 12VDC 1A NO VE	R	6920WRD008A
RY3	6920W2D010A	RELAY	OJ-SS-112LM OEG 250VAC 3A 12VDC 1A NO VE	R	6920W2D010B
U01	0IZZW5A076A	IC,DRAWING	TMP87PM14N 64 BK TMP87CH14N OTP	R	
ZD1	0DZ510009AD	DIODE,ZENERS	UZ5.1B ROHM TP52 DO34 500MW 5.1V 10UA NA	R	
ZD2	0DZ750009BB	DIODE,ZENERS	UZ-7.5BS PYUNG CHANG TP52 DO34 500MW 7.5	R	

R: SERVICE PARTS



P/NO : 3828W5S3026

Mar., 2002
Printed in China