

SAFETY.CAT.COM™

SAFETY

Operation and Maintenance
Manual Excerpt



Operation and Maintenance Manual

XQ230 and XQ300 Rental Generator Sets

X3R1-Up (Generator Set)

Important Safety Information

Most accidents that involve product operation, maintenance and repair are caused by failure to observe basic safety rules or precautions. An accident can often be avoided by recognizing potentially hazardous situations before an accident occurs. A person must be alert to potential hazards. This person should also have the necessary training, skills and tools to perform these functions properly.

Improper operation, lubrication, maintenance or repair of this product can be dangerous and could result in injury or death.

Do not operate or perform any lubrication, maintenance or repair on this product, until you have read and understood the operation, lubrication, maintenance and repair information.

Safety precautions and warnings are provided in this manual and on the product. If these hazard warnings are not heeded, bodily injury or death could occur to you or to other persons.

The hazards are identified by the "Safety Alert Symbol" and followed by a "Signal Word" such as "DANGER", "WARNING" or "CAUTION". The Safety Alert "WARNING" label is shown below.



The meaning of this safety alert symbol is as follows:

Attention! Become Alert! Your Safety is Involved.

The message that appears under the warning explains the hazard and can be either written or pictorially presented.

Operations that may cause product damage are identified by "NOTICE" labels on the product and in this publication.

Caterpillar cannot anticipate every possible circumstance that might involve a potential hazard. The warnings in this publication and on the product are, therefore, not all inclusive. If a tool, procedure, work method or operating technique that is not specifically recommended by Caterpillar is used, you must satisfy yourself that it is safe for you and for others. You should also ensure that the product will not be damaged or be made unsafe by the operation, lubrication, maintenance or repair procedures that you choose.

The information, specifications, and illustrations in this publication are on the basis of information that was available at the time that the publication was written. The specifications, torques, pressures, measurements, adjustments, illustrations, and other items can change at any time. These changes can affect the service that is given to the product. Obtain the complete and most current information before you start any job. Caterpillar dealers have the most current information available.



When replacement parts are required for this product Caterpillar recommends using Caterpillar replacement parts or parts with equivalent specifications including, but not limited to, physical dimensions, type, strength and material.

Failure to heed this warning can lead to premature failures, product damage, personal injury or death.

Safety Section

i02386525

Safety Messages

SMCS Code: 1000; 7405

There may be several specific safety messages on your generator set package. The exact location and a description of the safety messages are reviewed in this section. Please become familiar with all safety messages.

Ensure that all of the safety messages are legible. Clean the safety messages or replace the safety messages if the words cannot be read or if the illustrations are not visible. Use a cloth, water, and soap to clean the safety messages. Do not use solvents, gasoline, or other harsh chemicals. Solvents, gasoline, or harsh chemicals could loosen the adhesive that secures the safety messages. The safety messages that are loosened could drop off of the generator set package.

Replace any safety message that is damaged or missing. If a safety message is attached to a part of the generator set package that is replaced, install a new safety message on the replacement part. Your Caterpillar dealer can provide new safety messages.

WARNING

Do not operate or work on this engine unless you have read and understand the instructions and warnings in the Operation and Maintenance Manual. Failure to follow the instructions or heed the warnings could result in injury or death. Contact any Caterpillar dealer for replacement manuals. Proper care is your responsibility.

The warning labels that may be found on the generator set package are illustrated and described.

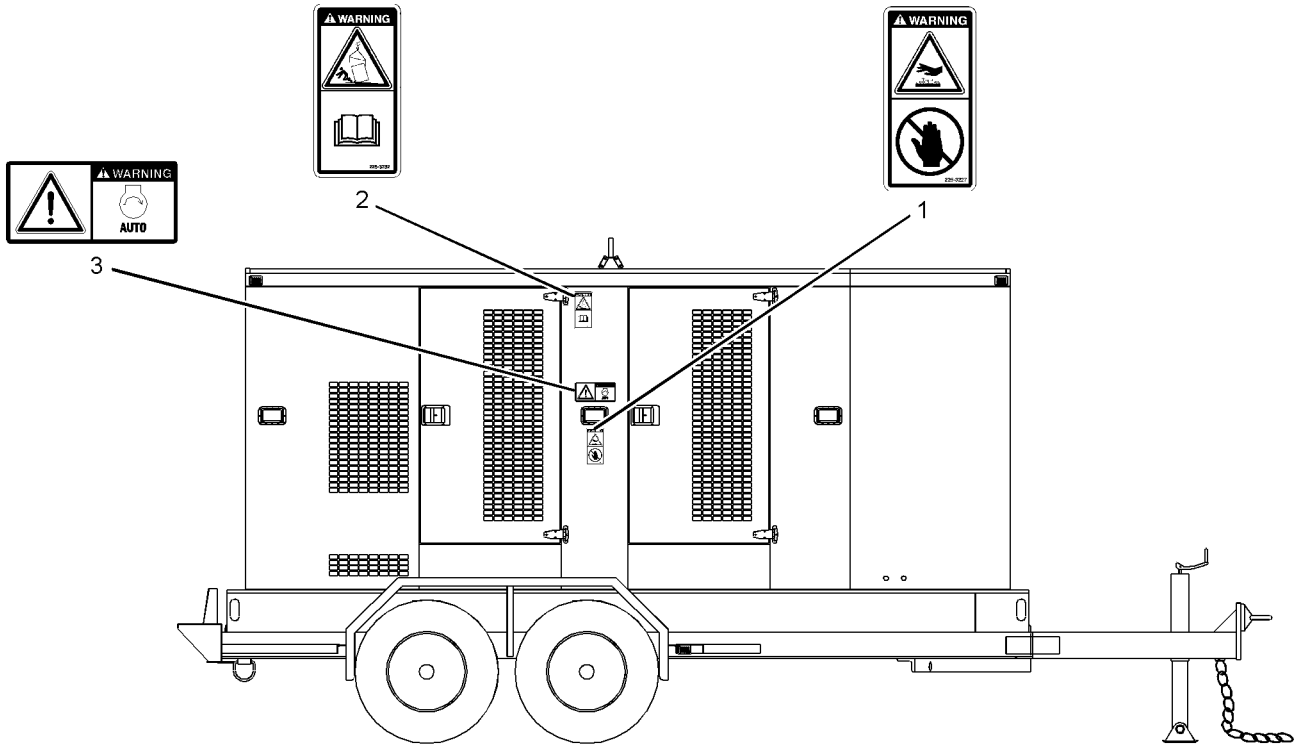

Illustration 1
Side view of the enclosure for the generator set

g01190681

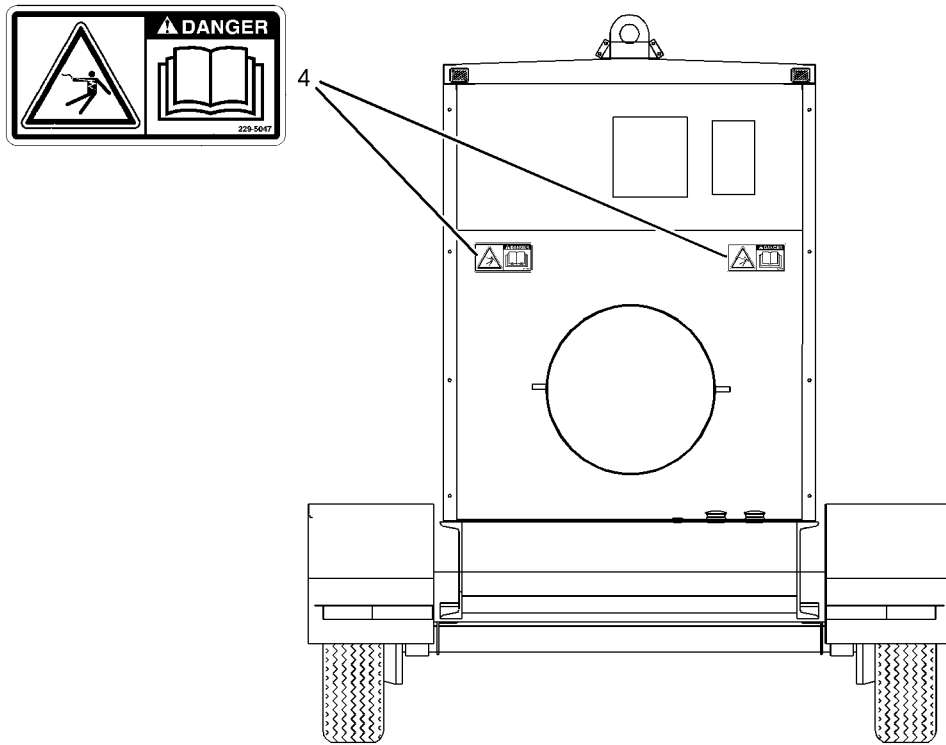

Illustration 2
View of the electrical bulkhead that is located inside of the enclosure

g01199904

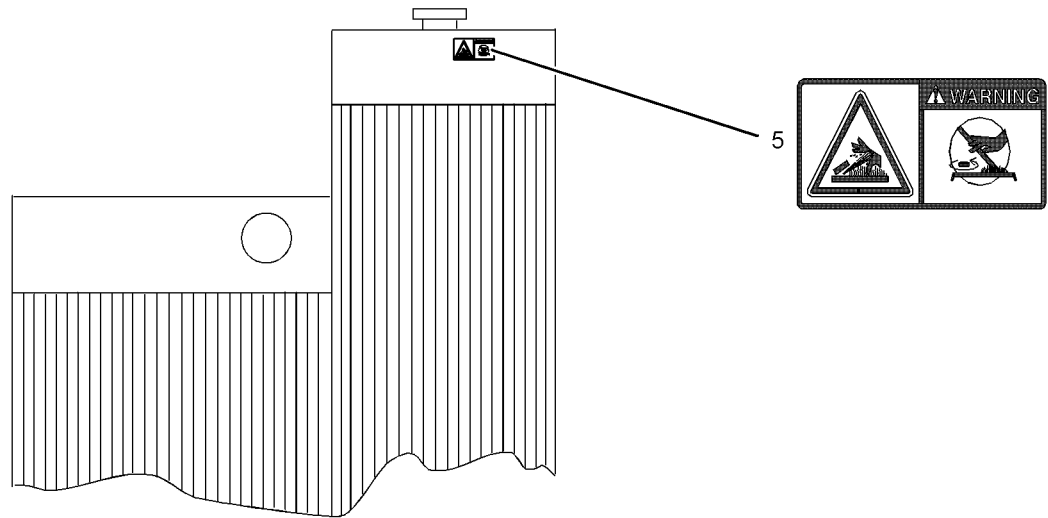

Illustration 3
View of radiator from the inside of the enclosure

g01199939

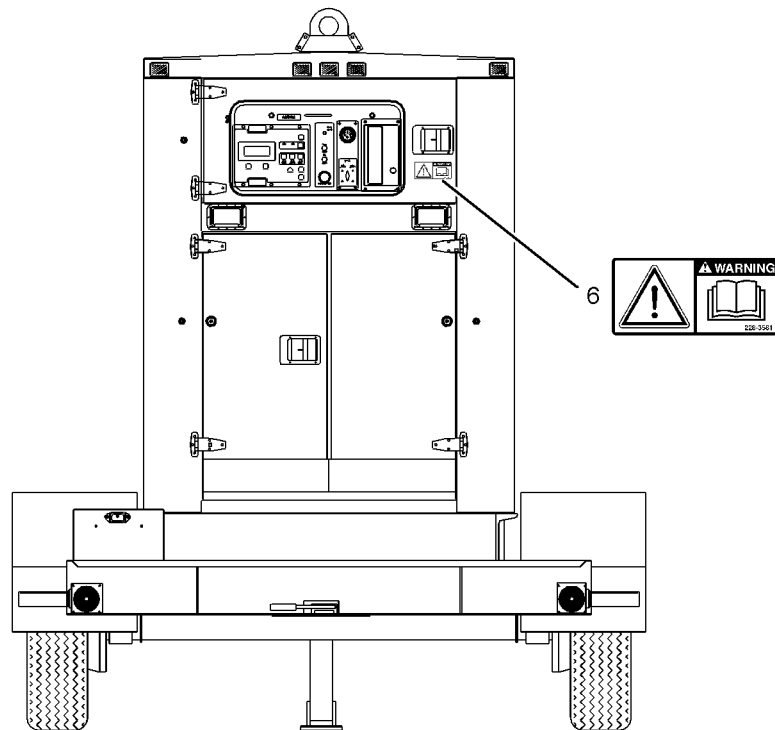

Illustration 4
Rear of the enclosure

g01193922

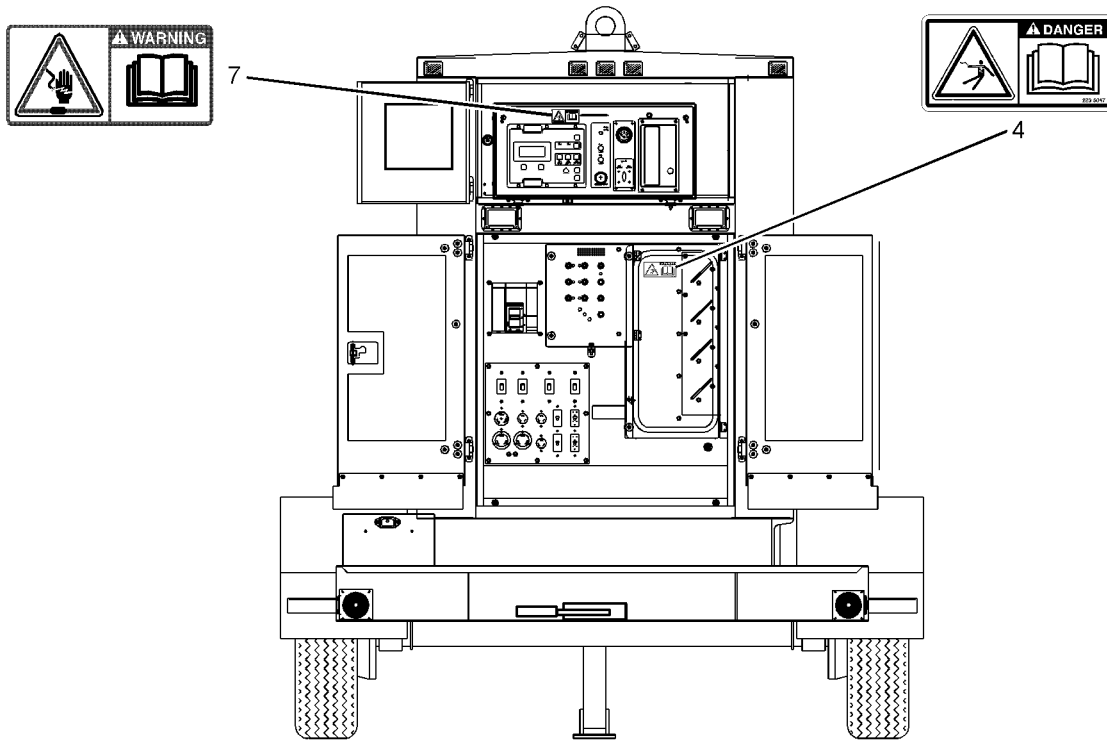

Illustration 5
Rear view of the enclosure

g01193865

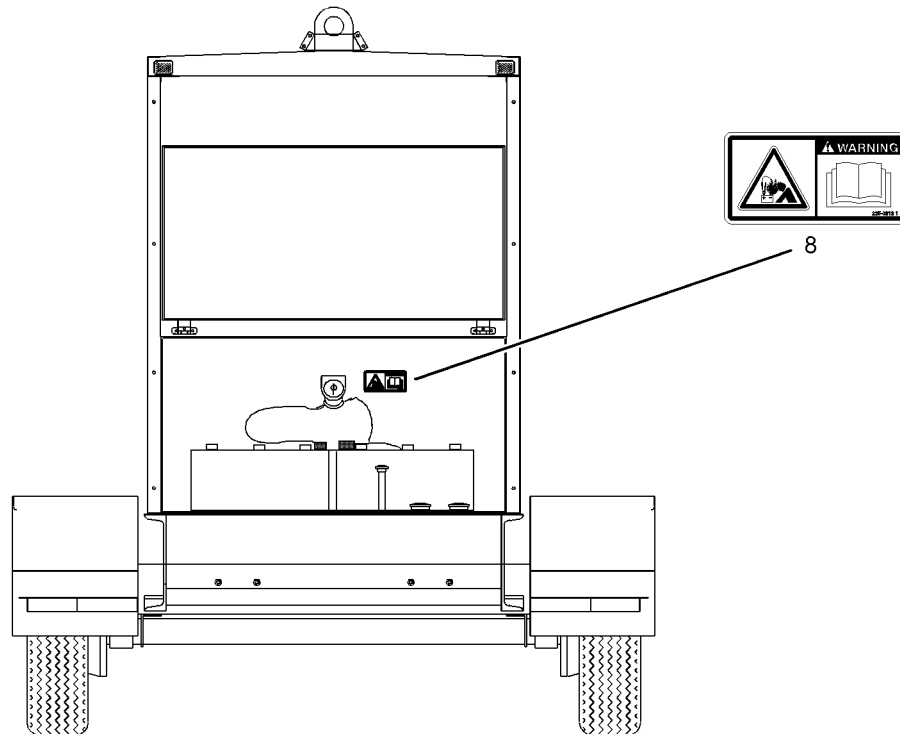

Illustration 6
Front view of the enclosure

g01193964

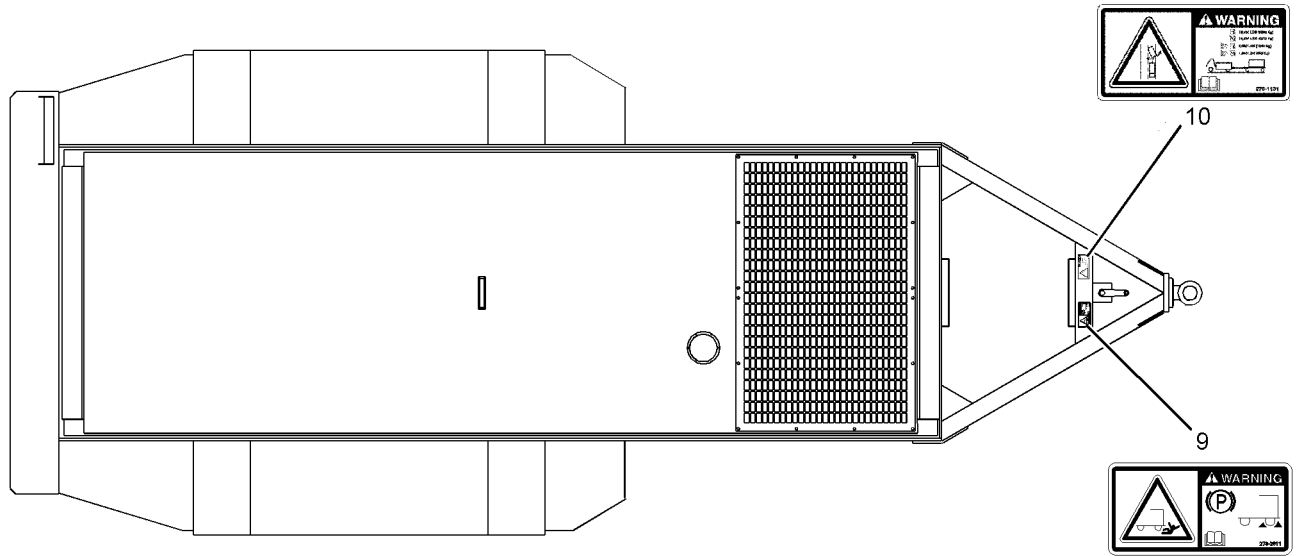

Illustration 7
Top view of the generator set

g01194068

Hot Surface (1)

This safety message for hot surfaces is located on the sides of the enclosure.

Lifting the Generator Set (2)

This safety message for lifting the generator set is located on the sides of the enclosure.

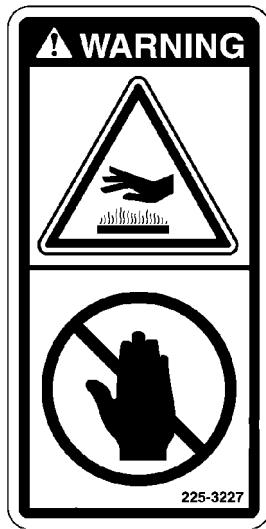

g00943659

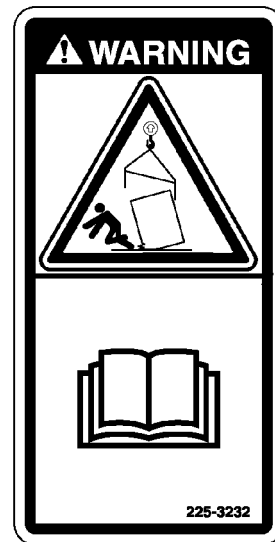

g00928085

⚠ WARNING

Hot parts or hot components can cause burns or personal injury. Do not allow hot parts or components to contact your skin. Use protective clothing or protective equipment to protect your skin.

⚠ WARNING

Crushing Hazard! Improper lifting could cause serious injury or death. Follow the lifting instructions in the Operation and Maintenance Manual for safe lifting procedures.

Automatic Starting (3)

This safety message is located on the side of the enclosure on enclosed generator sets. This safety message is located on the side of the generator on open generator sets. This safety message is also located on the enclosure for the breakers on open generator sets and enclosed generator sets.



g01154070

⚠ WARNING

When the engine is in the AUTOMATIC mode, the engine can start at any moment. To avoid personal injury, always remain clear of the the engine when the engine is in the AUTOMATIC mode.

Electrocution (4)

This safety message is located on the top of the generator. This safety message is also located on the enclosure for the control panel and the load panel.

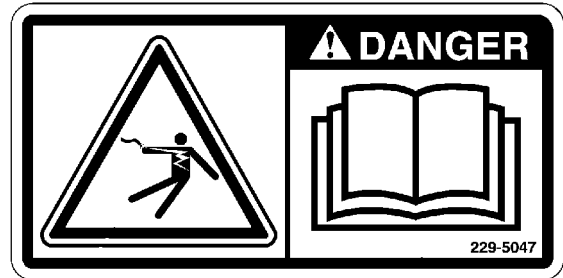

g00928349

⚠ DANGER

DANGER: Shock/Electrocution Hazard-Do not operate this equipment or work on this equipment unless you have read and understand the instructions and warnings in the Operation and Maintenance Manual. Failure to follow the instructions or heed the warnings will result in serious injury or death.

⚠ WARNING

Do not connect generator to a utility electrical distribution system unless it is isolated from the system. Electrical feedback into the distribution system can occur and could cause personal injury or death.

Open and secure main distribution system switch, or if the connection is permanent, install a double throw transfer switch to prevent electrical feedback. Some generators are specifically approved by a utility to run in parallel with the distribution system and isolation may not be required. Always check with your utility as to the applicable circumstances.

Hot Fluid Under Pressure (5)

The safety message for hot fluid under pressure is located toward the top of the radiator by the filler neck.



g00930639



Pressurized system! Hot coolant can cause serious burns, injury or death. To open the cooling system filler cap, stop the engine and wait until the cooling system components are cool. Loosen the cooling system pressure cap slowly in order to relieve the pressure. Read and understand the Operation and Maintenance Manual before performing any cooling system maintenance.

Universal Warning (6)

This safety message is located on the rear of the enclosure.

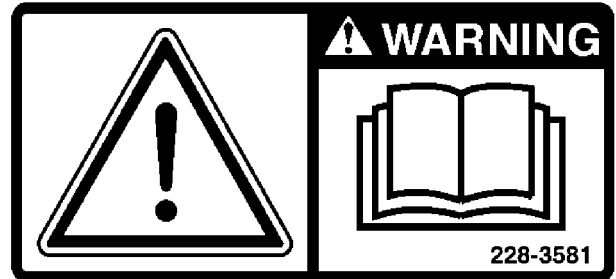

g00934493



Do not operate or work on this equipment unless you have read and understand the instructions and warnings in the Operation and Maintenance Manuals. Failure to follow the instructions or heed the warnings could result in serious injury or death.

Electrical Shock (7)

The safety message for electrical shock is located on the control panel.

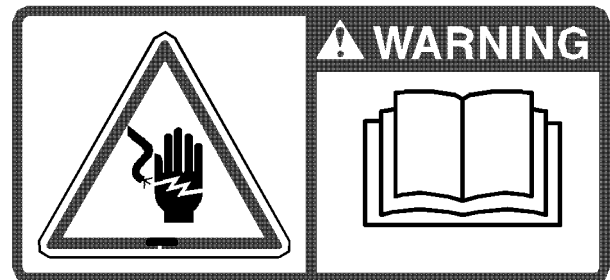

g01120247



WARNING! Shock/Electrocution Hazard! Read and understand the instructions and warnings in the Operation and Maintenance Manual. Failure to follow the instructions or heed the warnings could cause serious injury or death.

Jumper Cables (8)

This safety message is located above the batteries in the battery compartment.



g01067366



Explosion Hazard! Improper jumper cable connections can cause an explosion resulting in serious injury or death. Batteries may be located in separate compartments. When using jump start cables, always connect the positive (+) cable from the source to the positive (+) terminal of the battery that is connected to the starter solenoid. Connect the negative (-) cable from the source to the negative (-) terminal of the starter. If the machine is not equipped with a starter negative terminal, connect the negative (-) cable to the engine block. Follow the procedure in the Operation and Maintenance Manual.

Chock Wheels (9)

This safety message is located on the tongue of the trailer.



g01194172



Do not uncouple the trailer from the towing vehicle until the wheels are securely blocked or chocked. Failure to do so could result in injury.

Towing the Trailer (10)

The safety message for towing the trailer is located on the tongue of the trailer.



g01194185

WARNING

Failure to utilize an appropriate and properly sized tow vehicle with a level-horizontal hitch connection could lead to excessive towing sway resulting in personal injury or death.

For trailer with adjustable hitch, inspect the torque on the hitch bolts. Required torque is 370 ± 50 N·m (273 ± 37 lb ft).

The capacities of the tow vehicle are given for towing the generator set with a full fuel tank and the capacities are given for towing the generator set with an empty fuel tank.

For towing the generator set with a full fuel tank, the tow vehicle must be rated for towing a trailer of at least 8000 kg (16,550 lb).

For towing the generator set with an empty fuel tank, the tow vehicle must be rated for towing a trailer of at least 6210 kg (13,690 lb).

For towing the generator set with a full fuel tank, the rating for the tongue weight of the hitch of the tow vehicle must be at least 1043 kg (2,300 lb).

For towing the generator set with an empty fuel tank, the rating for the tongue weight of the hitch of the tow vehicle must be at least 862 kg (1,900 lb).

Additional Messages

i02402356

SMCS Code: 1000; 7405

There are several specific messages on these machines. The exact location of the messages and the description of the messages are reviewed in this section. Please become familiarized with all messages.

Make sure that all of the messages are legible. Clean the messages or replace the messages if the words or images are unreadable. When you clean the messages, use a cloth, water and soap. Do not use solvent, gasoline, or other harsh chemicals to clean the messages. Solvents, gasoline, or harsh chemicals could loosen the adhesive that secures the messages. Loose adhesive will allow the messages to fall.

Replace any message that is damaged, or missing. If a message is attached to a part that is replaced, install a message on the replacement part. Any Caterpillar dealer can provide new messages.

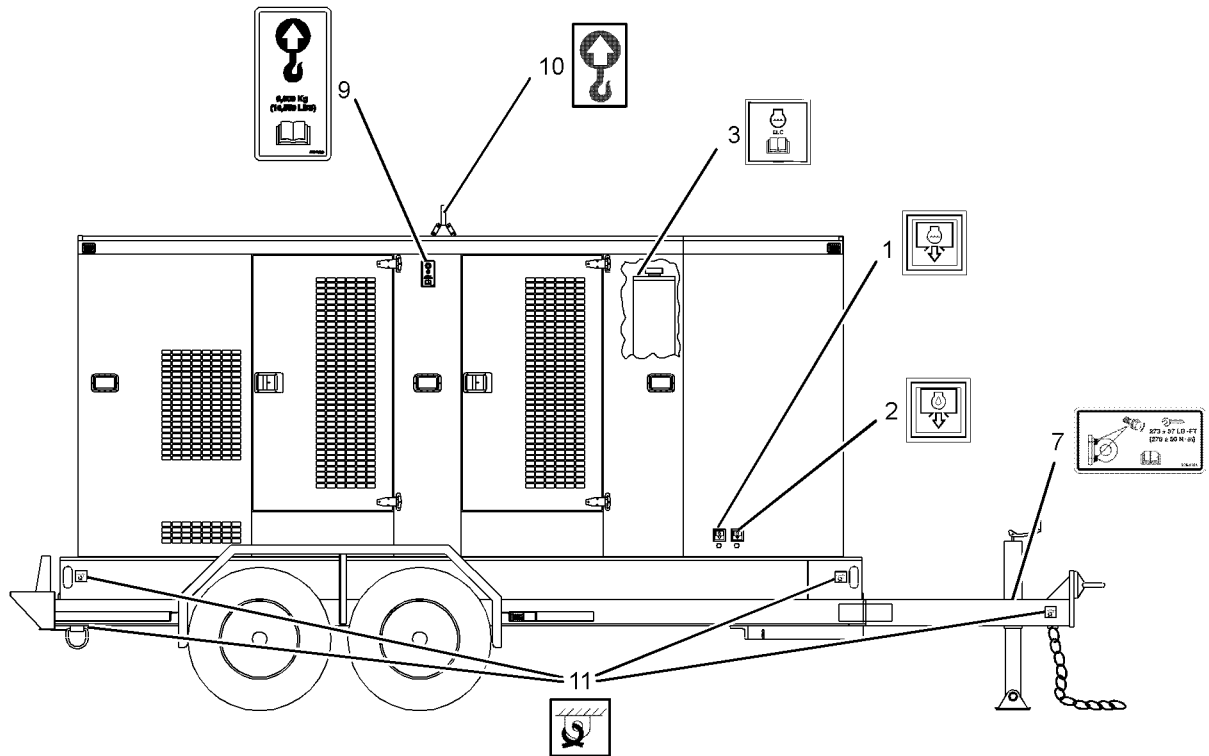

Illustration 8
Right side view of the generator set

g01200854

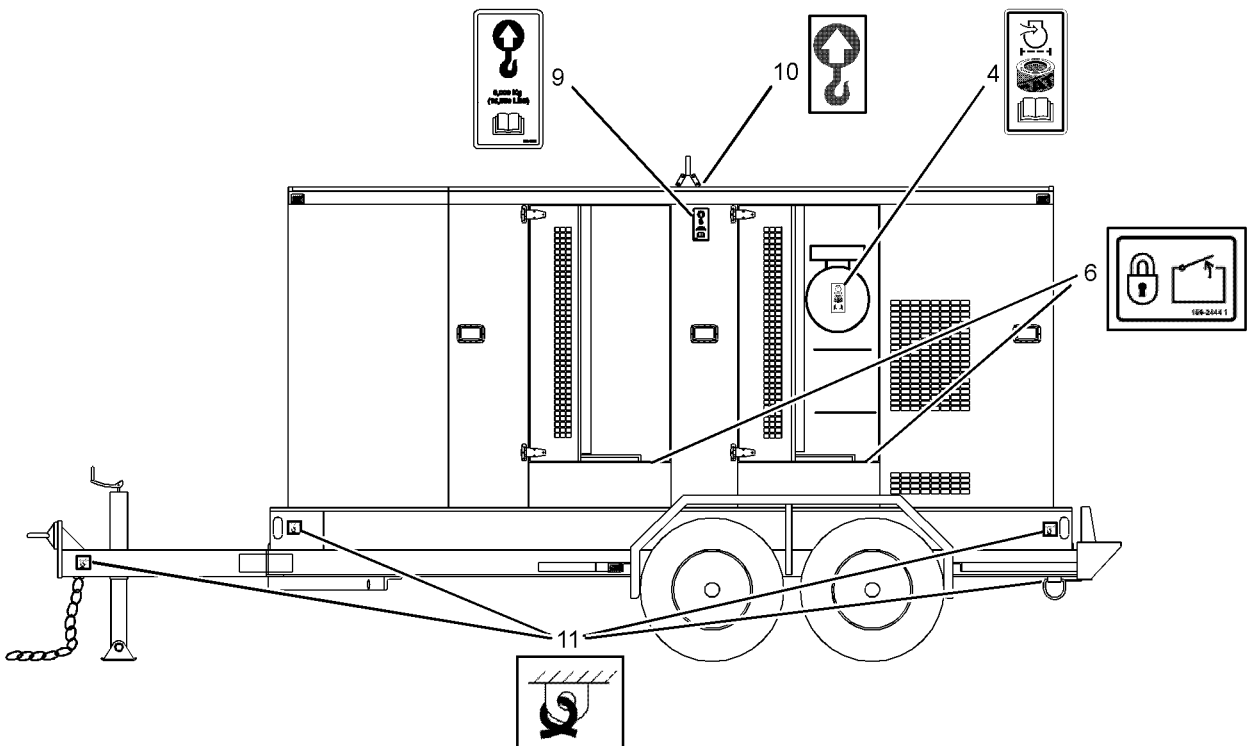

Illustration 9
Left side view of the generator set with the doors open.

g01200744

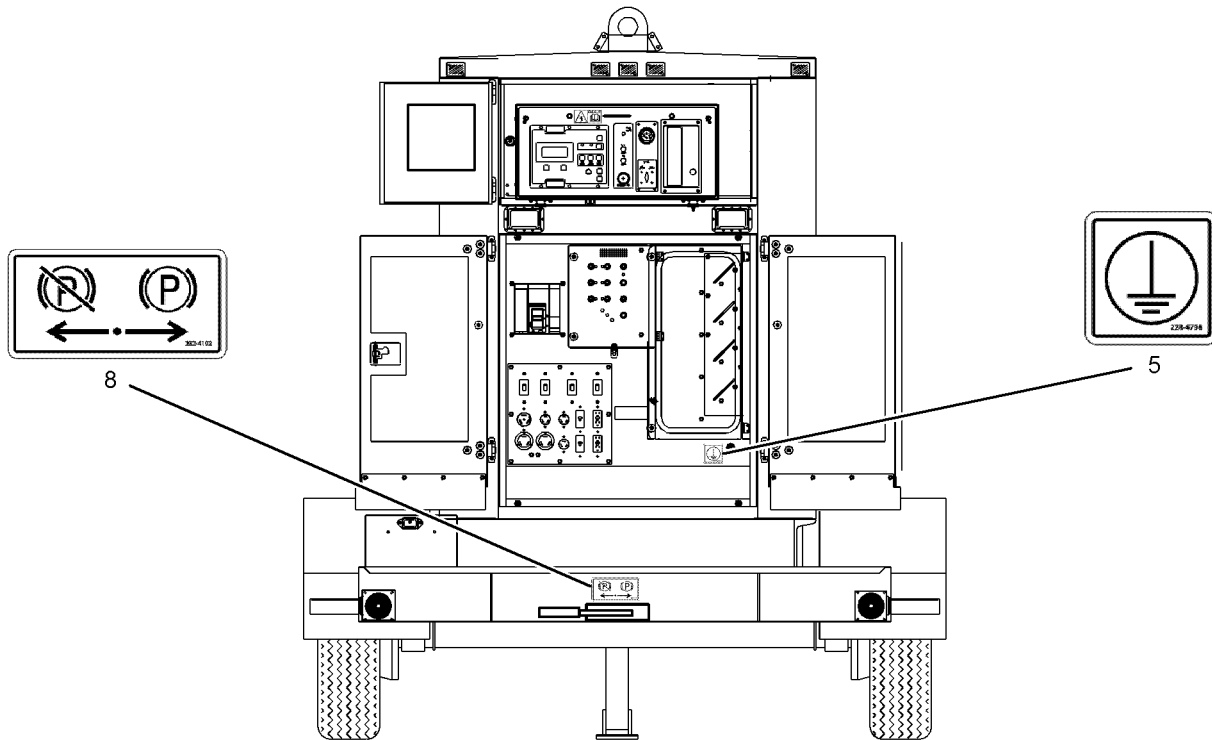

Illustration 10
Rear view of the generator set

g01200914

Engine coolant drain (1)

This message is located on the side of the generator set toward the bottom of the generator set.

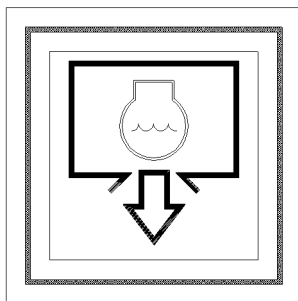

Illustration 11

g01151053

This is the location of the engine coolant drain. Refer to this Operation and Maintenance Manual, "Cooling System Coolant (ELC) - Change".

WARNING

Personal injury can result from hot coolant. Any contact with hot coolant or with steam can cause severe burns. Allow cooling system components to cool before the cooling system is drained.

Engine oil drain (2)

This message is located on the side of the generator set toward the bottom of the generator set.

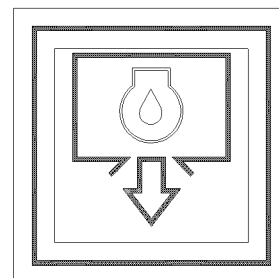

Illustration 12

g01151083

This is the location of the engine oil drain. Refer to this Operation and Maintenance Manual, "Engine Oil and Filter - Change".

⚠ WARNING

Hot oil and components can cause personal injury. Do not allow hot oil or components to contact skin.

Cat ELC (Extended Life Coolant) (3)

This message is located near the radiator filler cap.

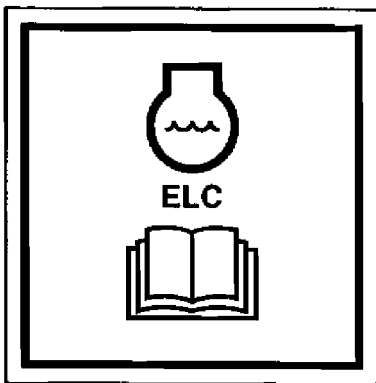

Illustration 13

g01132922

Air cleaner (4)

This message is located on the cover of the air cleaner. The air cleaner is located inside the engine compartment on the right side of the machine.

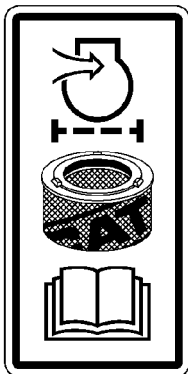

Illustration 14

g01169444

To avoid engine damage, use only Caterpillar radial seal air filters as replacement filters. Refer to the following topics for correct replacement instructions:

- Operation and Maintenance Manual, "Engine Air Filter Primary Element - Clean/Replace"
- Operation and Maintenance Manual, "Engine Air Filter Secondary Element - Replace"

Ground (5)

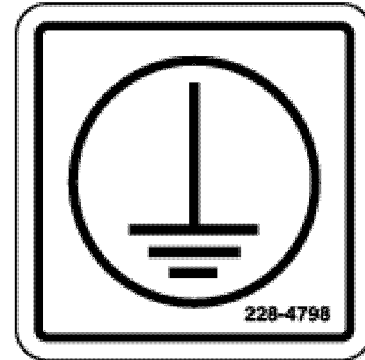

Illustration 15

g01200346

This message is located on the control panel by the connection for grounding the generator set. This connection is the ground for the generator frame. This connection must be connected to a suitable earth ground with a resistance of no more than 25 ohms. Refer to the following topic:

- Operation and Maintenance Manual, "Setup"

Prop rod for the doors(6)

This message is located at the bottom of the opening for the doors on the enclosure.

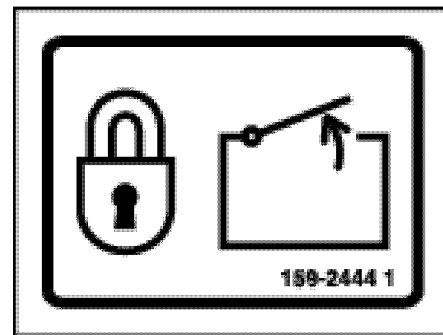

Illustration 16

g01200429

Use the prop rod in order to secure the doors of the generator set in the open position. The prop rod is stored on the bottom of the door. Use the clip on the bottom of the door to store the prop rod when the doors are closed.

Torque for the bolts (7) that fasten the eye to the trailer

This message is located on the tongue of the trailer.

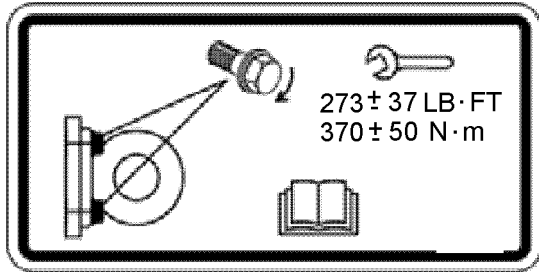

Illustration 17

g01200452

Tighten the bolts that fasten the eye to the tongue of the trailer to a torque of 370 ± 50 N·m (273 ± 37 lb ft).

Parking brake (8)

This message is located above the lever for the parking brake at the rear of the trailer.

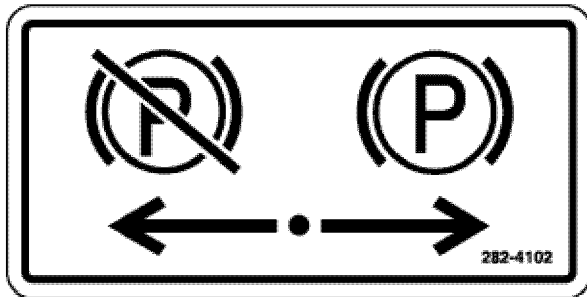

Illustration 18

g01200437

To apply the parking brake, pull the lever outward and pull the lever to the right. Adjust the tension for the parking brake by turning the lever. To disengage the parking brake, pull the lever to the left and push the lever inward.

Single point lifting eye (9)

This message is located on the side of the enclosure near the top of the enclosure.

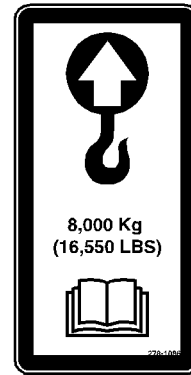

Illustration 19

g01200730

The single point lifting eye is rated at 8000 kg (16,550 lb).

Lifting point (10)

This message is located by the single point lifting eye.



Illustration 20

g01034418

Lift the package from this point. Refer to the following topic:

- Operation and Maintenance Manual, "Product Lifting"

Tie-down point (11)

This message is located on the bottom of the generator set and on the trailer.

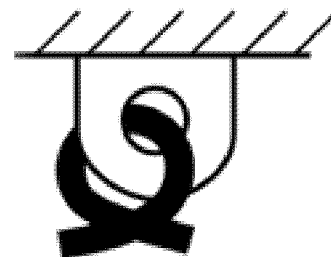

Illustration 21

g01200450

Use these points to tie down the generator set for various shipping configurations.

i02965953

General Hazard Information

SMCS Code: 1000; 7405

Attach a “Do Not Operate” warning tag or a similar warning tag to the start switch or to the controls before the engine is serviced or before the engine is repaired. These warning tags (Special Instruction, SEHS7332) are available from your Caterpillar dealer. Attach the warning tags to the engine and to each operator control station. When it is appropriate, disconnect the starting controls.

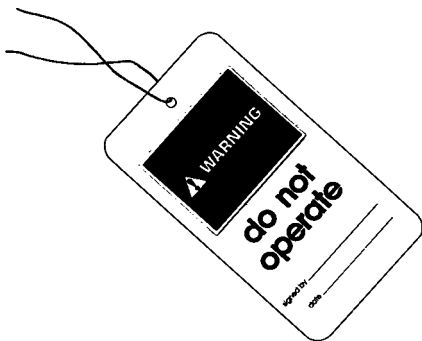

Illustration 22

g00104545

Do not allow unauthorized personnel on the engine or around the engine when the engine is serviced.

Engine exhaust contains products of combustion which may be harmful to your health. Always start the engine and operate the engine in a well ventilated area. If the engine is in an enclosed area, vent the engine exhaust to the outside.

Cautiously remove the following parts:

Note: To help prevent spraying or splashing of pressurized fluids, hold a rag over the part that is being removed.

- Filler caps
- Grease fittings
- Pressure taps
- Breathers
- Drain plugs

Use caution when cover plates are removed. Gradually loosen but do not remove the last two bolts or nuts that are located at opposite ends of the cover plate or the device. Before removing the last two bolts or nuts, pry the cover loose in order to relieve any spring pressure or other pressure.

- Wear a hard hat, protective glasses, and other protective equipment, as required.
- Do not attempt any repairs that are not understood. Use the proper tools. Replace any equipment that is damaged or repair the equipment.
- When work is performed around an engine that is operating, wear protective devices for ears in order to help prevent damage to hearing.
- Do not wear loose clothing or jewelry that can snag on controls or on other parts of the engine.
- Ensure that all protective guards and all covers are secured in place on the engine.
- Never put maintenance fluids into glass containers. Glass containers can break.
- Use all cleaning solutions with care.
- Report all necessary repairs.

Unless other instructions are provided, perform the maintenance under the following conditions:

- The engine is stopped. Ensure that the engine cannot be started.
- The protective locks or the controls are in the applied position.
- Disconnect the batteries when maintenance is performed or when the electrical system is serviced. Disconnect the battery ground leads. Tape the leads in order to help prevent sparks.
- For initial start-up of a new engine or for starting an engine that has been serviced, make provisions to stop the engine if an overspeed occurs. This may be accomplished by shutting off the fuel supply and/or the air supply to the engine.
- Start the engine with the operator controls. Never short across the starting motor terminals or the batteries. This could bypass the engine neutral start system and/or the electrical system could be damaged.

Pressurized Air and Water

Pressurized air and/or water can cause debris and/or hot water to be blown out. This could result in personal injury.

When pressurized air and/or pressurized water is used for cleaning, wear protective clothing, protective shoes, and eye protection. Eye protection includes goggles or a protective face shield.

The maximum air pressure for cleaning purposes must be reduced to 205 kPa (30 psi) when the air nozzle is deadheaded and used with effective chip guarding (if applicable) and personal protective equipment. The maximum water pressure for cleaning purposes must be below 275 kPa (40 psi). Always wear eye protection for cleaning the cooling system.

Fluid Penetration

Always use a board or cardboard when the engine components are checked for leaks. Leaking fluid that is under pressure can cause serious injury or possible death. This includes leaks that are the size of a pin hole.

If fluid is injected into the skin, seek treatment immediately. Seek treatment from a doctor that is familiar with this type of injury.

Containing Fluid Spillage

Care must be used in order to ensure that the fluids are contained during the inspection, the maintenance, the testing, the adjusting, and the repair of the engine. Prepare to collect the fluid with suitable containers before any compartment is opened or before any component is disassembled.

Refer to Catalog, NENG2500, "Caterpillar Dealer Service Tool Catalog" for the following items:

- Tools that are suitable for collecting fluids and equipment that is suitable for collecting fluids

Obey all local regulations for the disposal of liquids.

Asbestos Information

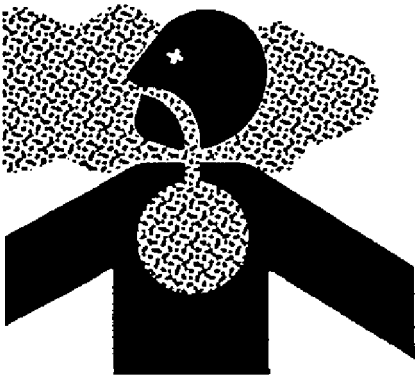

Illustration 23

g00702022

Caterpillar equipment and replacement parts that are shipped from Caterpillar are asbestos free. Caterpillar recommends the use of only genuine Caterpillar replacement parts. Use the following guidelines when you handle any replacement parts that contain asbestos or when you handle asbestos debris.

Use caution. Avoid inhaling dust that might be generated when you handle components that contain asbestos fibers. Inhaling this dust can be hazardous to your health. The components that may contain asbestos fibers are brake pads, brake bands, lining material, clutch plates, and some gaskets. The asbestos that is used in these components is usually bound in a resin or sealed in some way. Normal handling is not hazardous unless airborne dust that contains asbestos is generated.

If dust that may contain asbestos is present, there are several guidelines that should be followed:

- Never use compressed air for cleaning.
- Avoid brushing materials that contain asbestos.
- Avoid grinding materials that contain asbestos.
- Use a wet method in order to clean up asbestos materials.
- A vacuum cleaner that is equipped with a high efficiency particulate air filter (HEPA) can also be used.
- Use exhaust ventilation on permanent machining jobs.
- Wear an approved respirator if there is no other way to control the dust.
- Comply with applicable rules and regulations for the work place. In the United States, use Occupational Safety and Health Administration (OSHA) requirements. These OSHA requirements can be found in "29 CFR 1910.1001".
- Obey environmental regulations for the disposal of asbestos.
- Stay away from areas that might have asbestos particles in the air.

Lines, Tubes, and Hoses

Do not bend or strike high pressure lines. Do not install lines, tubes, or hoses that are damaged.

Repair any fuel lines, oil lines, tubes, or hoses that are loose or damaged. Leaks can cause fires.

Inspect all lines, tubes and hoses carefully. Do not use bare hands to check for leaks. Always use a board or cardboard for checking engine components for leaks. Tighten all connections to the recommended torque.

Check for the following conditions:

- End fittings that are damaged or leaking
- Outer covering that is chafed or cut
- Wire that is exposed in reinforced hose
- Outer covering that is ballooning locally
- Flexible part of the hose that is kinked or crushed
- Armoring that is embedded in the outer covering

Ensure that all of the clamps, the guards, and the heat shields are installed correctly. This will help to prevent these effects: vibration, rubbing against other parts, and excessive heat during operation.

Dispose of Waste Properly

Improperly disposing of waste can threaten the environment. Potentially harmful fluids should be disposed of according to local regulations.

Always use leakproof containers when you drain fluids. Do not pour waste onto the ground, down a drain, or into any source of water.

i01480768

Burn Prevention

SMCS Code: 1000; 7405

Do not touch any part of an operating engine. Allow the engine to cool before any maintenance is performed on the engine. Relieve all pressure in the air system, in the hydraulic system, in the lubrication system, in the fuel system, or in the cooling system before any lines, fittings or related items are disconnected.

Coolant

When the engine is at operating temperature, the engine coolant is hot. The coolant is also under pressure. The radiator and all lines to the heaters or to the engine contain hot coolant.

Any contact with hot coolant or with steam can cause severe burns. Allow cooling system components to cool before the cooling system is drained.

Check the coolant level after the engine has stopped and the engine has been allowed to cool.

Ensure that the filler cap is cool before removing the filler cap. The filler cap must be cool enough to touch with a bare hand. Remove the filler cap slowly in order to relieve pressure.

Cooling system conditioner contains alkali. Alkali can cause personal injury. Do not allow alkali to contact the skin, the eyes, or the mouth.

Oils

Hot oil and hot lubricating components can cause personal injury. Do not allow hot oil to contact the skin. Also, do not allow hot components to contact the skin.

Batteries

Electrolyte is an acid. Electrolyte can cause personal injury. Do not allow electrolyte to contact the skin or the eyes. Always wear protective glasses for servicing batteries. Wash hands after touching the batteries and connectors. Use of gloves is recommended.

i01372262

Fire Prevention and Explosion Prevention

SMCS Code: 1000; 7405



Illustration 24

g00704000

All fuels, most lubricants, and some coolant mixtures are flammable.

Flammable fluids that are leaking or spilled onto hot surfaces or onto electrical components can cause a fire. Fire may cause personal injury and property damage.

A flash fire may result if the covers for the engine crankcase are removed within fifteen minutes after an emergency shutdown.

Determine whether the engine will be operated in an environment that allows combustible gases to be drawn into the air inlet system. These gases could cause the engine to overspeed. Personal injury, property damage, or engine damage could result.

If the application involves the presence of combustible gases, consult your Caterpillar dealer for additional information about suitable protection devices.

Remove all flammable materials such as fuel, oil, and debris from the engine. Do not allow any flammable materials to accumulate on the engine.

Store fuels and lubricants in properly marked containers away from unauthorized persons. Store oily rags and any flammable materials in protective containers. Do not smoke in areas that are used for storing flammable materials.

Do not expose the engine to any flame.

Exhaust shields (if equipped) protect hot exhaust components from oil or fuel spray in case of a line, a hose, or a seal failure. Exhaust shields must be installed correctly.

Do not weld on lines or tanks that contain flammable fluids. Do not flame cut lines that contain flammable fluid. Clean any such lines thoroughly with a nonflammable solvent prior to welding or flame cutting.

Wiring must be kept in good condition. All electrical wires must be properly routed and securely attached. Check all electrical wires daily. Repair any wires that are loose or frayed before you operate the engine. Clean all electrical connections and tighten all electrical connections.

Eliminate all wiring that is unattached or unnecessary. Do not use any wires or cables that are smaller than the recommended gauge. Do not bypass any fuses and/or circuit breakers.

Arcing or sparking could cause a fire. Secure connections, recommended wiring, and properly maintained battery cables will help to prevent arcing or sparking.

Inspect all lines and hoses for wear or for deterioration. The hoses must be properly routed. The lines and hoses must have adequate support and secure clamps. Tighten all connections to the recommended torque. Leaks can cause fires.

Oil filters and fuel filters must be properly installed. The filter housings must be tightened to the proper torque.



Illustration 25

g00704135

Gases from a battery can explode. Keep any open flames or sparks away from the top of a battery. Do not smoke in battery charging areas.

Never check the battery charge by placing a metal object across the terminal posts. Use a voltmeter or a hydrometer.

Improper jumper cable connections can cause an explosion that can result in injury. Refer to the Operation Section of this manual for specific instructions.

Do not charge a frozen battery. This may cause an explosion.

The batteries must be kept clean. The covers (if equipped) must be kept on the cells. Use the recommended cables, connections, and battery box covers when the engine is operated.

Fire Extinguisher

Make sure that a fire extinguisher is available. Be familiar with the operation of the fire extinguisher. Inspect the fire extinguisher and service the fire extinguisher regularly. Obey the recommendations on the instruction plate.

Lines, Tubes and Hoses

Do not bend high pressure lines. Do not strike high pressure lines. Do not install any lines that are bent or damaged.

i01377941

Repair any lines that are loose or damaged. Leaks can cause fires. Consult your Caterpillar dealer for repair or for replacement parts.

Check lines, tubes and hoses carefully. Do not use your bare hand to check for leaks. Use a board or cardboard to check for leaks. Tighten all connections to the recommended torque.

Replace the parts if any of the following conditions are present:

- End fittings are damaged or leaking.
- Outer coverings are chafed or cut.
- Wires are exposed.
- Outer coverings are ballooning.
- Flexible part of the hoses are kinked.
- Outer covers have embedded armoring.
- End fittings are displaced.

Make sure that all clamps, guards, and heat shields are installed correctly. During engine operation, this will help to prevent vibration, rubbing against other parts, and excessive heat.

i01359666

Crushing Prevention and Cutting Prevention

SMCS Code: 1000; 7405

Support the component properly when work beneath the component is performed.

Unless other maintenance instructions are provided, never attempt adjustments while the engine is running.

Stay clear of all rotating parts and of all moving parts. Leave the guards in place until maintenance is performed. After the maintenance is performed, reinstall the guards.

Keep objects away from moving fan blades. The fan blades will throw objects or cut objects.

When objects are struck, wear protective glasses in order to avoid injury to the eyes.

Chips or other debris may fly off objects when objects are struck. Before objects are struck, ensure that no one will be injured by flying debris.

Mounting and Dismounting

SMCS Code: 1000; 7405

Generator sets in permanent installations may require the use of a ladder or a work platform in order to provide access for normal maintenance. The owner and/or the user is responsible for providing safe access that conforms to SAE J185 and/or local building codes.

Inspect the steps, the handholds, and the work area before mounting the generator set. Keep these items clean and keep these items in good repair.

Mount the generator set and dismount the generator set only at locations that have steps and/or handholds. Do not climb on the generator set, and do not jump off the generator set.

Face the generator set in order to mount the generator set or dismount the generator set. Maintain a three-point contact with the steps and handholds. Use two feet and one hand or use one foot and two hands. Do not use any controls as handholds.

Do not jump from an elevated platform. Do not jump from a ladder or stairs.

Do not stand on components which cannot support your weight. Use an adequate ladder or use a work platform. Secure the climbing equipment so that the equipment will not move.

Do not carry tools or supplies when you mount the generator set or when you dismount the generator set. Use a hand line to raise and lower tools or supplies.

i02404480

Before Starting Engine

SMCS Code: 1000

NOTICE

For initial start-up of a new or rebuilt engine, and for start-up of an engine that has been serviced, make provision to shut the engine off should an overspeed occur. This may be accomplished by shutting off the air and/or fuel supply to the engine.

Overspeed shutdown should occur automatically. If automatic shutdown does not occur, press the emergency stop button in order to cut the fuel and/or air to the engine.

Inspect the engine for potential hazards.

Before starting the engine, ensure that no one is on, underneath, or close to the engine. Ensure that the area is free of personnel.

If equipped, ensure that the lighting system for the engine is suitable for the conditions. Ensure that all lights work properly, if equipped.

Ensure that the exhaust system is properly clamped. Ensure that the connections are tight. Check for leaks. Check the condition of all connections and components of the exhaust system.

All protective guards and all protective covers must be installed if the engine must be started in order to perform service procedures. To help prevent an accident that is caused by parts in rotation, work around the parts carefully.

Do not bypass the automatic shutoff circuits. Do not disable the automatic shutoff circuits. The circuits are provided in order to help prevent personal injury. The circuits are also provided in order to help prevent engine damage.

See the Service Manual for repairs and for adjustments.

i02404509

Engine Starting

SMCS Code: 1000

WARNING

Do not use aerosol types of starting aids such as ether. Such use could result in an explosion and personal injury.

If a warning tag is attached to the engine start switch or to the controls, DO NOT start the engine or move the controls. Consult with the person that attached the warning tag before the engine is started.

All protective guards and all protective covers must be installed if the engine must be started in order to perform service procedures. To help prevent an accident that is caused by parts in rotation, work around the parts carefully.

Start the engine from the operator's compartment or from the engine start switch.

Always start the engine according to the procedure that is described in this Operation and Maintenance Manual, "Engine Starting" topic (Operation Section). Knowing the correct procedure will help to prevent major damage to the engine components. Knowing the procedure will also help to prevent personal injury.

To ensure that the jacket water heater (if equipped) and/or the lube oil heater (if equipped) is working properly, check the water temperature gauge and the oil temperature gauge during the heater operation.

Engine exhaust contains products of combustion that can be harmful to your health. Always start the engine and operate the engine in a well ventilated area. If the engine is started in an enclosed area, vent the engine exhaust to the outside.

i01462046

Engine Stopping

SMCS Code: 1000

Stop the engine according to the procedure in the Operation and Maintenance Manual, "Engine Stopping (Operation Section)" in order to avoid overheating of the engine and accelerated wear of the engine components.

Use the Emergency Stop Button (if equipped) ONLY in an emergency situation. Do not use the Emergency Stop Button for normal engine stopping. After an emergency stop, DO NOT start the engine until the problem that caused the emergency stop has been corrected.

Stop the engine if an overspeed condition occurs during the initial start-up of a new engine or an engine that has been overhauled. This may be accomplished by shutting off the fuel supply to the engine and/or shutting off the air supply to the engine.

To stop an electronically controlled engine, cut the power to the engine.

i02353436

Electrical System

SMCS Code: 1000; 1400

Never disconnect any charging unit circuit or battery circuit cable from the battery when the charging unit is operating. A spark can cause the combustible gases that are produced by some batteries to ignite.

To help prevent sparks from igniting combustible gases that are produced by some batteries, the negative "-" jump start cable should be connected last from the external power source to the negative "-" terminal of the starting motor. If the starting motor is not equipped with a negative "-" terminal, connect the jump start cable to the engine block.

Check the electrical wires for wires that are loose or frayed. Tighten all loose electrical wires before the engine is operated. Repair all frayed electrical wires before the engine is started. See the Operation and Maintenance Manual, "Engine Starting" for specific starting instructions.

Grounding Practices

The electrical system for the engine must be properly grounded. Proper grounding is necessary for optimum engine performance and reliability. Improper grounding will result in uncontrolled electrical circuit paths and in unreliable electrical circuit paths.

Uncontrolled electrical circuit paths can result in damage to main bearings, to crankshaft bearing journal surfaces, and to aluminum components. Uncontrolled electrical circuit paths can also cause electrical noise.

The alternator, the starting motor, and all of the electrical systems **MUST** be grounded to the negative battery terminal.

For engines which have an alternator that is grounded to an engine component, a ground strap **MUST** connect that component to the negative battery terminal and the component **MUST** be electrically isolated from the engine.

A bus bar with a direct path to the negative "-" battery terminal is permissible and recommended for use for all components that require a negative "-" battery connection. The bus bar should be directly connected to the negative "-" battery terminal. A bonding cable should also be connected from the cylinder block to the bus bar on the negative "-" battery connection.

Use of a bus bar ensures that the Electronic Control Module (ECM) and all of the components that are connected to the ECM have a common reference point.