

Service Manual Trucks

Group **655-601**
Rear Suspension, T-Ride
VN, VHD

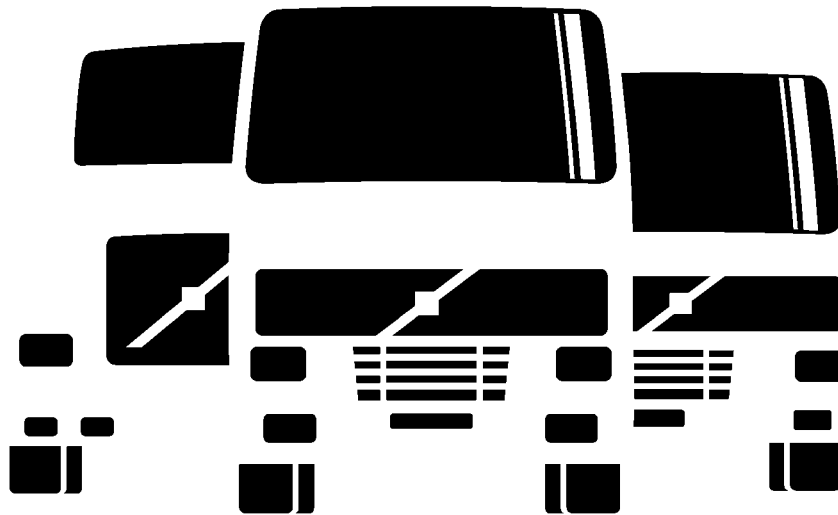

Foreword

The descriptions and service procedures contained in this manual are based on designs and methods studies carried out up to July 2003.

The products are under continuous development. Vehicles and components produced after the above date may therefore have different specifications and repair methods. When this is believed to have a significant bearing on this manual, supplementary service bulletins will be issued to cover the changes.

The new edition of this manual will update the changes.

In service procedures where the title incorporates an operation number, this is a reference to an V.S.T. (Volvo Standard Times).

Service procedures which do not include an operation number in the title are for general information and no reference is made to an V.S.T.

The following levels of observations, cautions and warnings are used in this Service Documentation:

Note: Indicates a situation, handling or circumstance which should be observed.

Caution: Indicates a potentially hazardous situation which, if not avoided, may result in minor or moderate injury or damage to property.

Warning: Indicates a potentially hazardous situation which, if not avoided, could result in death, serious injury or major damage to property.

Danger: Indicates an imminently hazardous situation which, if not avoided, will result in death or serious injury.

Volvo Trucks North America, Inc.
Greensboro, NC USA

Order number: PV776-TSP142921

© 2003 Volvo Trucks North America, Inc., Greensboro, NC USA

All rights reserved. No part of this publication may be reproduced, stored in retrieval system, or transmitted in any forms by any means, electronic, mechanical, photocopying, recording or otherwise, without the prior written permission of Volvo Trucks North America, Inc..

USA08313

Contents

General	3
Rear Suspension	3
Specifications	5
Suspension Applications	5
VHD	5
Tightening Torques	6
Axle Pinion Angles	7
VN	7
Tools	9
Special Tools	9
Other Tools	10
Design and Function	11
Rear Suspension	11
Bogie Bracket (Saddle Bracket)	12
Spring Cradle (Cradle Assembly)	12
Nylon Bushings	12
Parabolic Spring Leaves	13
Rubber Springs	13
V-Stay Torque Rods	13
Reaction Rod(Lower Torque Rod)	13
V-Stay Torque Rod Frame Bracket	14
Rubber Spring Bracket	14
Rubber Spring Plate	14
Lower Reaction Rod Bracket and Shock Bracket	14
Troubleshooting	17
Rear Suspension Troubleshooting	17
Volvo T-Ride	17
Service Procedures	19
Service Procedure	19
Guidelines for Working on the Volvo T-Ride Suspension	19
V Torque Rod, Replacement	21
Torque/Radius Rod, Lower, Replacement	23
Bogie Anchorage Assembly, Replacement	25
V Torque Rod Anchorage, Replacement	28
Spring Assembly, Rear Leaf, Removal and Installation	30
Rear Spring Leaf, Replacement	33
Rubber Spring, Replacement (Each)	35
Rear Spring Retaining Bolt, Replacement	38
Tandem, Alignment	40
Cradle, Replacement	41
Grease Seals, Replacement	45
Cradle Bearing, Lubrication	46
Permanent Fastener, Removal	47

General

Rear Suspension

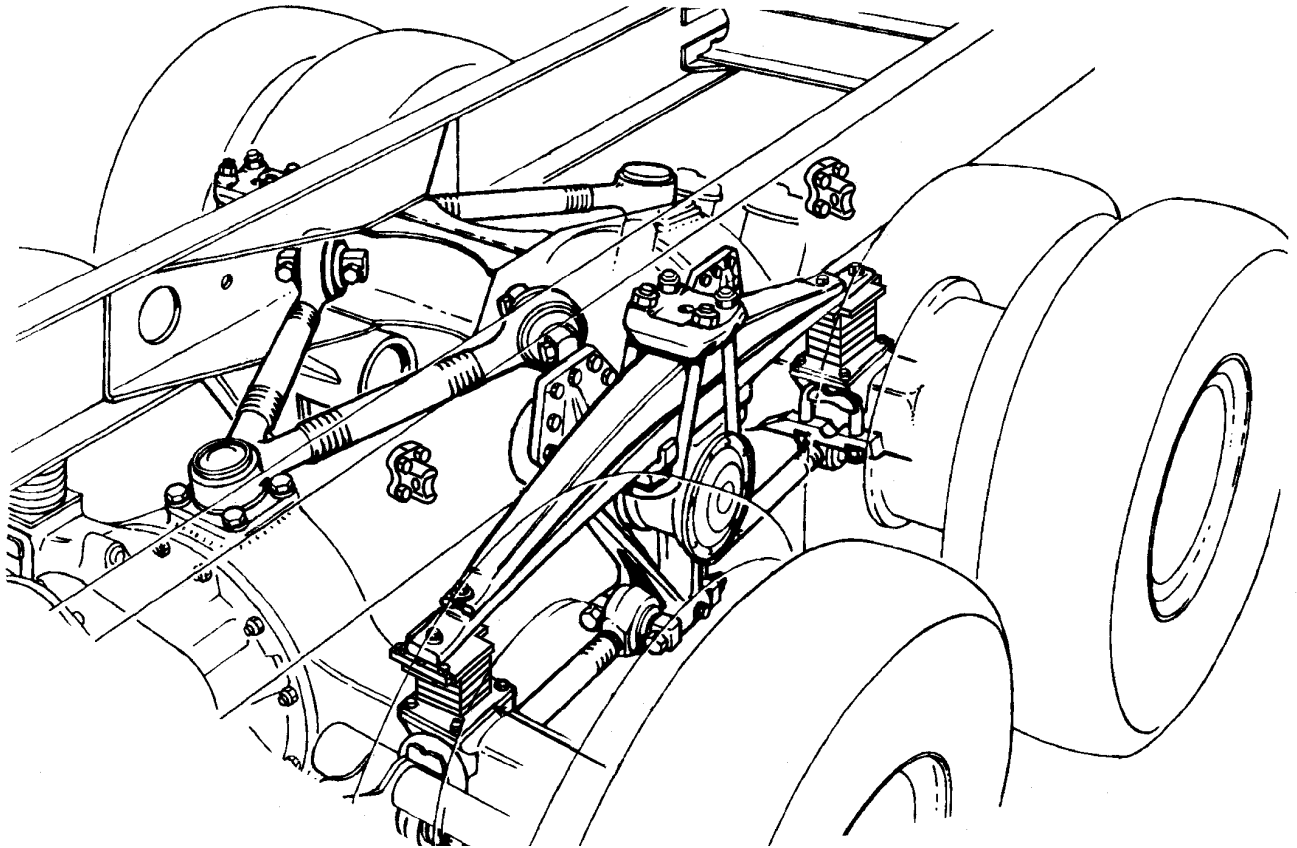

Fig. 1: T-Ride Tandem Suspension

W6001356

The Volvo T-Ride tandem suspension is designed for use in both on-and off-highway applications. It offers maximum articulation for maximum traction. The following information covers specifications, operations, torque values, lubrication, alignments, and service procedures for repair and maintenance of the Volvo T-Ride Tandem Suspension.

Specifications

Suspension Applications

VHD

Capacity (lb)	48,000	52,000	58,000	65,000	70,000
Volvo Axle	CTEV87, RT2610HV	CTEV87, RT2610HV	RT2610HV, RT3210HV	RT3210HV	RT3210HV
Meritor (Rockwell) Axle	Not Available	Not Available	Not Available	Not Available	Not Available
Dana (Eaton) Axle	Not Available	Not Available	Not Available	Not Available	Not Available
Load Distribution	50/50	50/50	50/50	50/50	50/50
Springs - Type	Parabolic/ Multileaf	Parabolic/ Multileaf	Parabolic/ Multileaf	Multileaf	Multileaf
Number of Leaves	3/9	3/11	3/9/11	9/11	9/11

	Nm	ft-lb
U-bolt nuts (sizes will vary) (do not re-use U-bolt nuts)	500 ± 75	369 ± 55
Cradle hubcap bolts	20 ± 5	15 ± 4
Lower torque rod bolt nuts to saddle bracket	220 ± 35	162 ± 26
Lower torque rod bolt nuts to axle bracket	320 ± 50	236 ± 37
V Torque rod nuts to axle housing	310 ± 50	228 ± 37
V Torque rod bolts to chassis bracket	320 ± 50	236 ± 37
Bogie bracket bolt nuts to chassis	320 ± 50	236 ± 37
Rubber spring bolts M14 to axle housing, VOLVO Axles	140 ± 25	103 ± 18
Rubber spring bolts M14 to axle housing, (Rockwell) (Eaton) Axles	200 ± 30	148 ± 22
Bottom spring plate bolts M12 to rubber spring	85 ± 15	63 ± 11
U-bolts to torque rod bracket on axle (do not re-use U-bolt nuts)	200 ± 25	148 ± 18
Bracket for V Torque rod bolt nuts to frame	320 ± 50	236 ± 37
Axle stop bolt nuts to frame (1)	140 ± 25	103 ± 18
Shock bracket to frame	200 ± 30	148 ± 22
Lower shock bracket to spacer on axle	320 ± 50	236 ± 37
Shock to frame mounted bracket	220 ± 35	162 ± 26
Shock to lower bracket	85 ± 15	63 ± 11

Tightening Torques

(1) These may be HUCKBOLT®, and if so, there is no torque value given as HUCKBOLT® are unserviceable.

Axle Pinion Angles

VN

Axle Variant	1st Axle	2nd Axle
Volvo Axle	3°	11°
Meritor (Rockwell) Axle	3°	11.5°
Dana (Eaton) Axle	3°	10°

Tools

Special Tools

The following special tools can be used when working on the T-Ride Tandem Suspension.

Volvo Tool 999–2337 (Pry Bar) can be used to remove seals, bearings, thrust washers and other items.

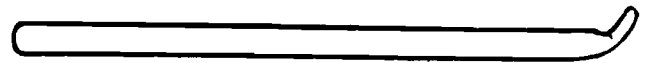

W6001361

Volvo Tool 998–8185 (Snap-Ring Pliers) are used for removing and installing snap rings.

Note: Protective eye wear should be worn when removing snap rings.

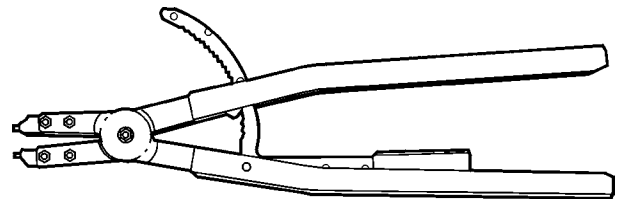

W6001359

Snap-On Tool A173 can be used to remove the inner thrust washer and other items.

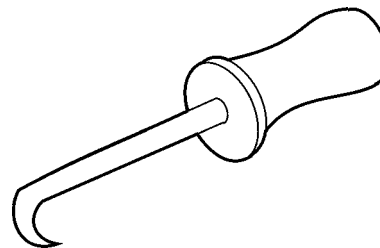

W6001360

Other Tools

The following tools can be used to ensure proper inclinations or angles for axles on the Volvo T-Ride:

The Anglemaster is a digital inclinometer, available from Dana-Spicer (Telephone: 419-535-4300).

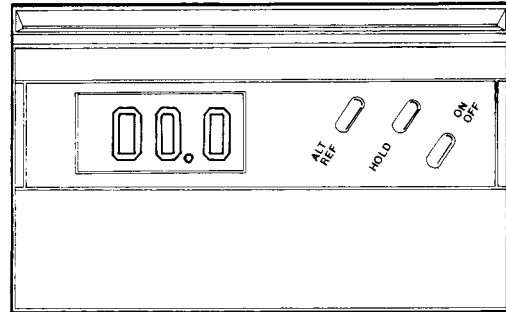

W7000250

The J-38460-A is a digital protractor, available from Kent-Moore (Telephone: 800-328-6657).

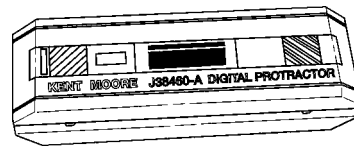

W7000708

The J-38460-25 may be used along with the Kent-Moore digital protractor or the Dana Spicer digital inclinometer for checking pinion angles. It is available from Kent-Moore (Telephone: 800-328-6657).

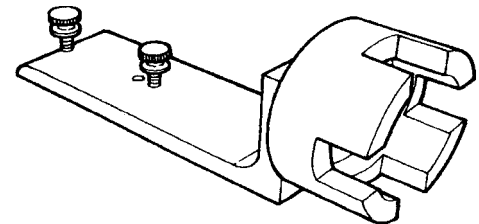

The J-36795 are tandem axle calipers, available from Kent-Moore (Telephone: 800-328-6657).

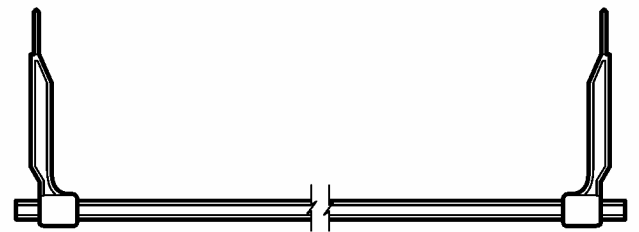

W0001985

Design and Function

Rear Suspension

The VOLVO T-Ride Tandem Suspension is designed for use in both on-and off-highway applications. It offers maximum articulation for traction. The parabolic tapered spring leaves are mounted upside-down outside the frame rails. The ride is further enhanced by rubber cushions bolted to the end of each spring resting on the respective rear axle. These cushions absorb shock and vibration.

The suspension features eight torque rods that help maintain the rear axle alignment. Four of the rods are installed on top of the rear axles in an opposite "V" pattern. These "V" torque rods anchor the rear axles to the frame, while distributing and maintaining laterally transmitted forces, as well as any starting and braking torques. The four lower torque rods also transfer starting and braking torques from the rear axles to the frame.

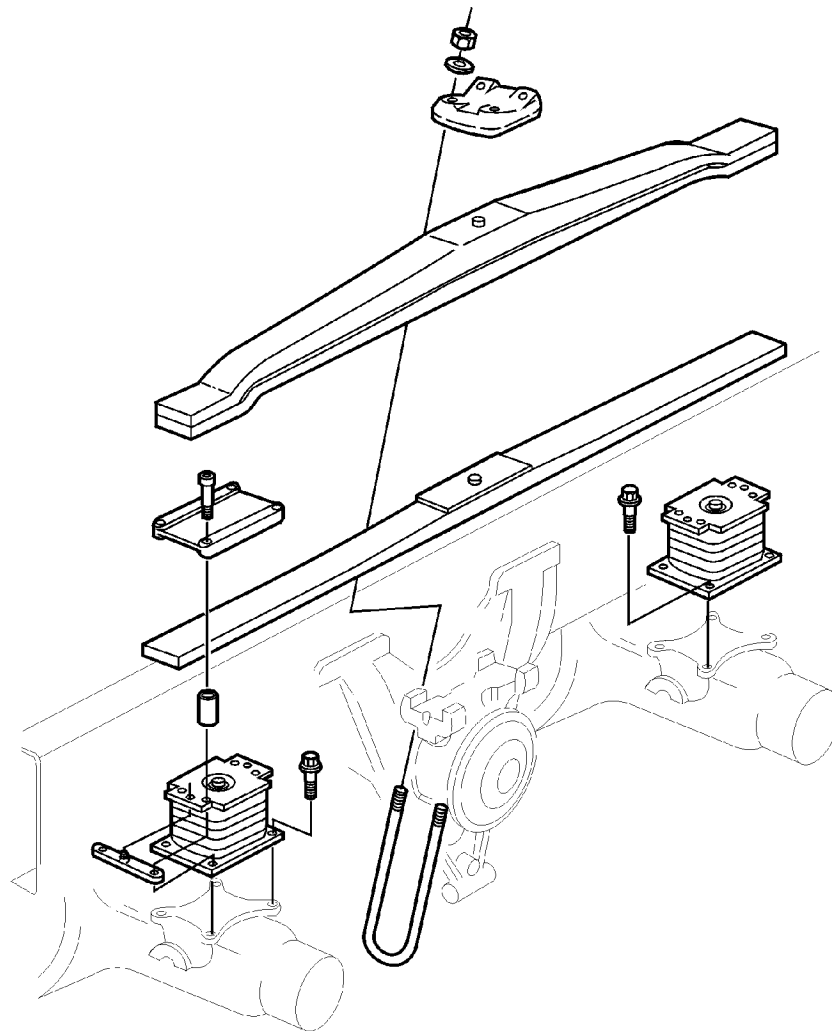

W6001331

Bogie Bracket (Saddle Bracket)

The Bogie Bracket assembly (saddle bracket) provides stability for lateral movement and serves as an anchor for the spring cradle and the parabolic spring assembly. It helps maintain maximum articulation of the suspension as well as durability. The Bogie Bracket plays a key role axially as well as radially.

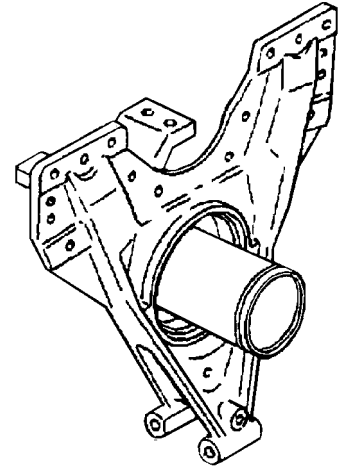

W6001336

Spring Cradle (Cradle Assembly)

The spring cradle (cradle assembly) provides maximum articulation for the suspension. The spring cradle functions axially as well as radially while riding on the trunnion tube in the Bogie Bracket. The axial play in the cradle is preset by the depth of the trunnion tube in the Bogie Bracket (saddle). The spring cradle also contains two nylon bushings which contain journals for lubricating the assembly.

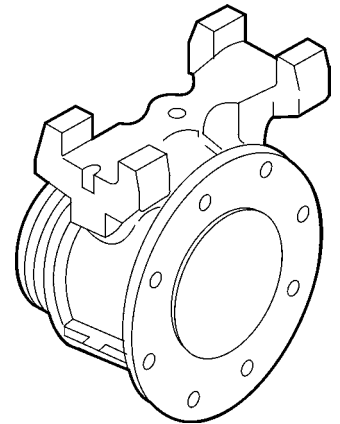

W6001340

Nylon Bushings

The nylon bushings serve as journals for lubrications both axially and radially. They are essential in maintaining life and serviceability of the spring cradle and trunnion tube. The nylon bushings help to simplify servicing the spring cradle.

Note: Nylon bushings should be replaced in pairs.

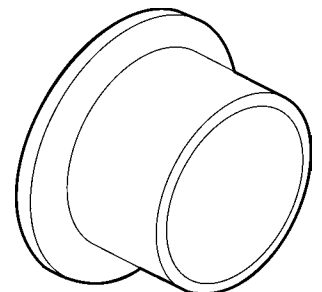

W6001339

Parabolic Spring Leaves

The parabolic spring leaves are mounted upside down and outside of the frame rails. They are fastened to the spring cradle and provide the lightweight suspension with excellent ride characteristics. This design contributes to axle flexibility while maintaining contact to the ground for pulling power.

Note: When replacing Parabolic Spring Leaves, the leaves on both sides should be replaced. When replacing the leaves also ensure that the leaves are marked with the same Camber Settings (+ or -).

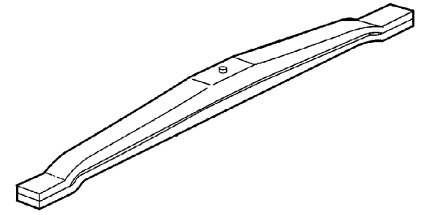

W6001341

Rubber Springs

The rubber springs support the leaf spring assembly and contribute to a flexible and comfortable ride. The rubber springs allow for minimum wear on the suspension by absorbing a considerable amount of shock and vibration for the suspension.

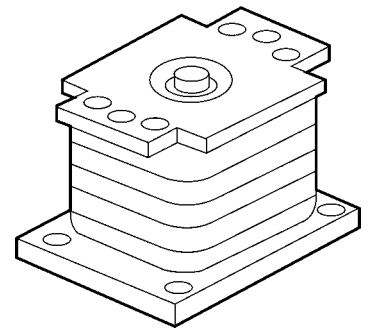

W6001343

V-Stay Torque Rods

The V-Stay torque rods distribute movement and keep the axles in place. They are fastened from the inner frame rails and to the top of the axle housings. They distribute and maintain laterally transmitted forces, as well as any starting or braking torques. The outer joints of the V-Stay torque rods are maintenance free.

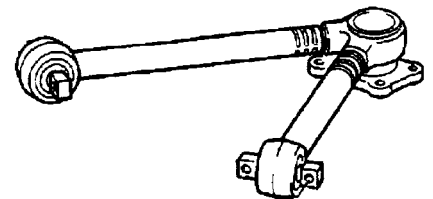

W6001334

Reaction Rod (Lower Torque Rod)

There are four lower torque rods and they are used to distribute starting and braking forces. The outer joints are also maintenance free. The axle pinion angle can be controlled by the reaction rods.

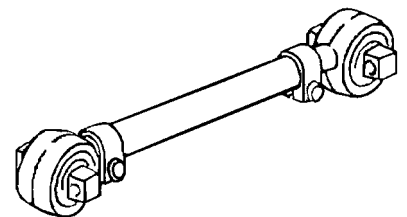

W6001335

V-Stay Torque Rod Frame

Bracket

The V-Stay torque rod frame bracket is used to mount the V-Stay torque rod to the frame. It is marked with top and forward arrows to make for proper installation. This bracket supplies a secure anchor for the V-Stay torque rod to the frame.

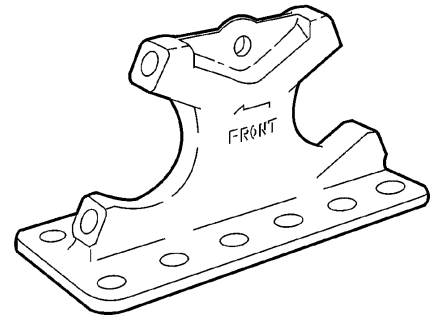

W6001322

Rubber Spring Bracket

The rubber spring bracket is found on top of the axle housing at the flanged end of the axle shaft. It is held in place with U-bolts and the lower reaction rod bracket. The rubber spring bracket provides a solid mounting surface for the rubber springs, which is essential to the alignment of the leaf spring assembly with the rubber spring.

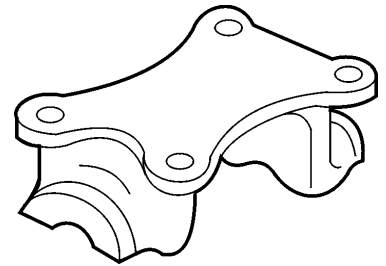

W6001337

Rubber Spring Plate

The rubber spring plate is used to fasten the lower leaf spring to the rubber springs. The rubber spring plate is important because it keeps the leaf springs in alignment with the rubber springs.

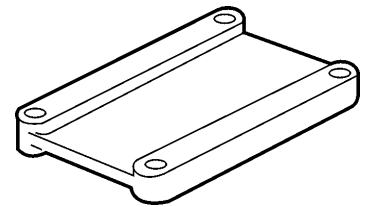

W6001342

Lower Reaction Rod Bracket and Shock Bracket

The reaction rod bracket provides a fixed location for the reaction rod to mount directly to the axle, as well as mounting the shock to the axle. This allows for proper positioning of those components leading to correct axle pinion angles and alignment.

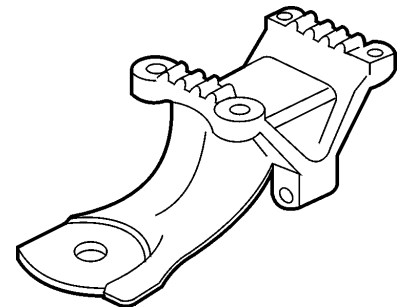

W6001338

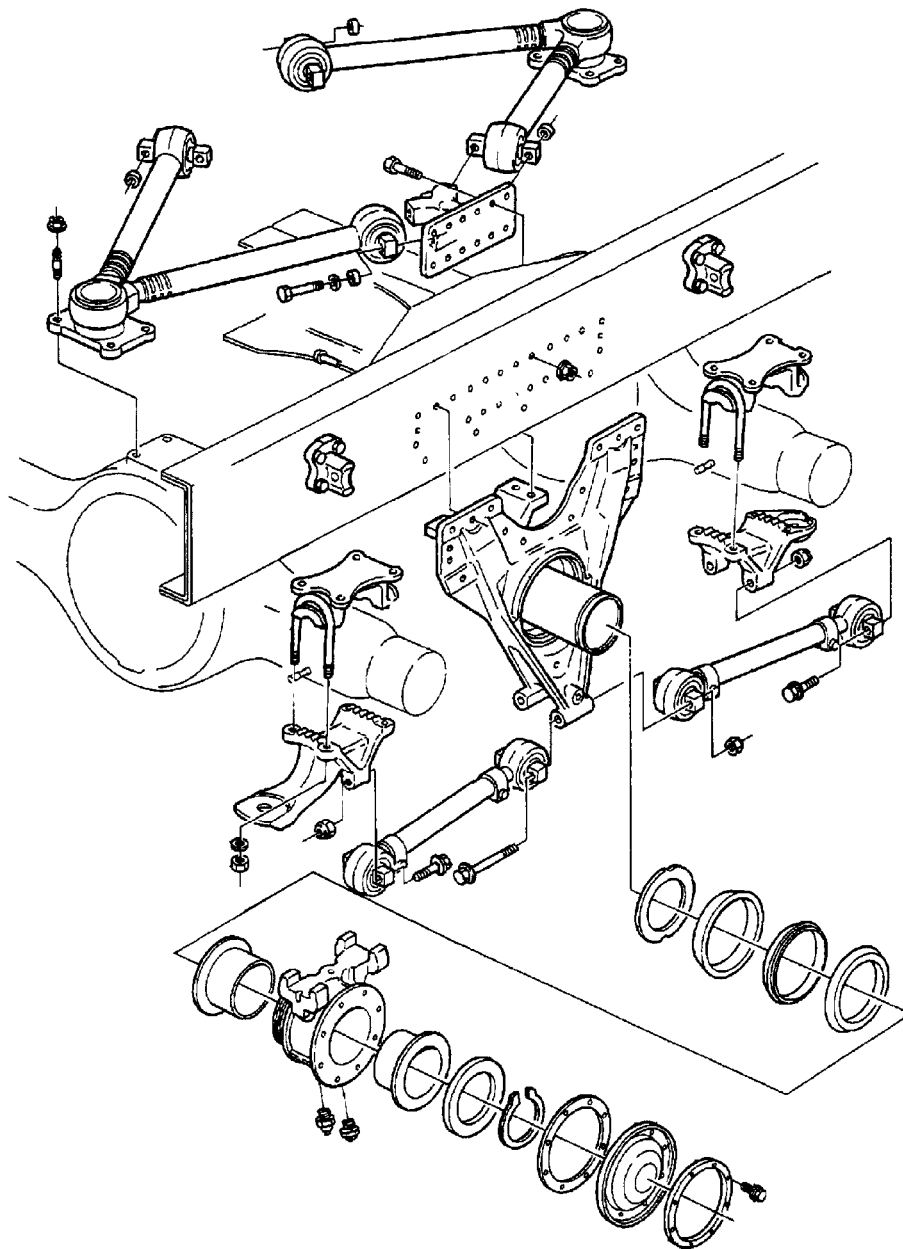

W6001328

Bogie Bracket and Cradle Assembly

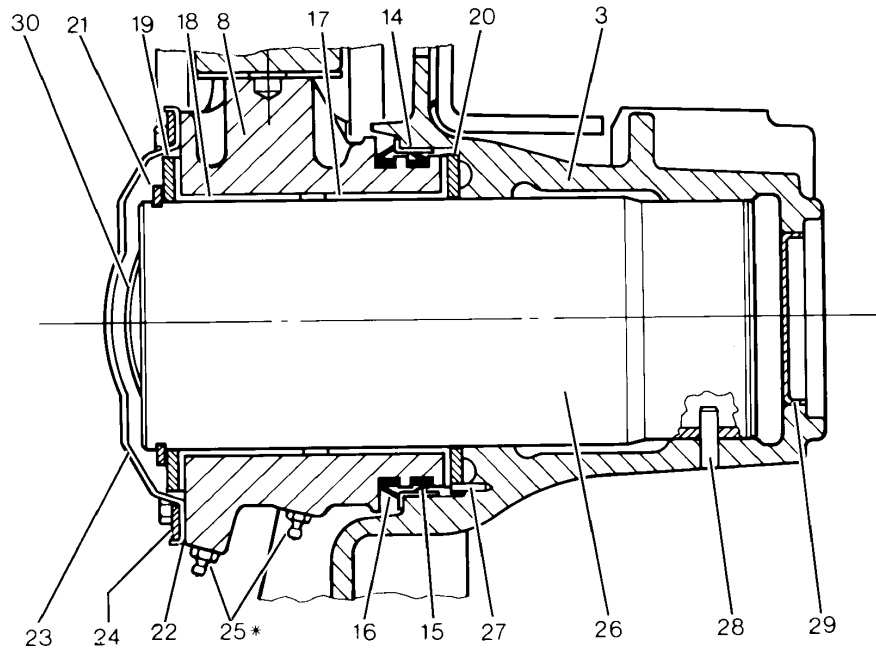

W7000091

3	Saddle Bracket	23	Hub Cab
8	Cradle	24	Retaining Ring
14	Wear Ring	25	Relief Valve
15	Grease Seal	26	Trunnion Tube
16	Grease Seal	27	Roll Pin
17	Nylon Bushing	28	Roll Pin
19	Outer Thrust Washer	29	Plug
20	Inner Thrust Washer	30	Plug
21	Snap Ring	31	Grease Fitting
22	Gasket		

Cross-Section View of Cradle and Saddle Bracket

Troubleshooting

Rear Suspension Troubleshooting

Volvo T-Ride

Problem	Cause
Vibration	U-joint angle incorrect
	Improper phasing of drivelines
	Axle inclination incorrect
	Thrust alignment incorrect
	Excessive end play on spring cradle
	Improper wheel run-out or balance
	Mismatched wheels and tires
	Excessive wheel bearing end play
Tracking	Improper thrust alignment
	Total wheel alignment incorrect
	Lateral alignment of axles incorrect
	Worn torque rod bushings
	Defective rubber spring
Excessively worn nylon bushings	(1) Improper lubrication will cause these components to fail prematurely or excessively
	Improper maintenance
	Excessive end play on cradle
Excessively worn trunion tube	(1) Improper lubrication will cause these components to fail prematurely or excessively
	Improper maintenance
	Excessive end play on cradle
	Overloaded vehicle
	Worn nylon bushings

(1) Refer to "Nylon Bushings" page 12.

Service Procedures

Service Procedure

Guidelines for Working on the Volvo T-Ride Suspension

You must read and understand the precautions and guidelines in Service Information, Group 60, "General Safety Practices, Wheel Suspension and Steering" before performing this procedure. If you are not properly trained and certified in this procedure, ask your supervisor for training before you perform it.

To ensure personal safety and to help avoid accidental damage to suspension components, always follow these guidelines any time work is performed on the suspension.

1

Always park the vehicle on a level surface, chock the front wheels and release the parking brakes.

2

When lifting the chassis to perform any procedure, always support the chassis with adequate jack stands before beginning work on the suspension.

3

For easier removal or installation of T-Ride Suspension components it may be necessary to remove the fifth wheel to adequately perform service procedures. Refer to the appropriate service literature for removing the fifth wheel.

4

To ensure that the U-bolts and Torque Rods holding the rear suspension to the drive axle retain their clamp load, observe the following practices:

Anytime you work on the suspension, make sure you loosen both sides of the suspension on an axle at the same time.

Note: It is difficult to realign all parts with opposite sides of the axle restricting motion.

Whenever the U-bolts and Torque Rods are loosened, always support the nose of the axle with an adequate jack.

Whenever the components are loosened, or the suspension components attached to the axle are being worked on, make sure that the locating features on each component are properly engaged so that the components are positioned together properly.

Using a hand held clicker-style torque wrench, always "snug-up" the U-bolt nuts all over before torquing.

5

After the necessary work has been performed on the B-Ride Tandem Suspension, vehicle realignment may be required. Refer to the proper service information.

6521-03-02-09 V Torque Rod, Replacement

Please read "Guidelines for Working on the Volvo T-Ride Suspension" page 19 before beginning this procedure.

1

Park the vehicle on a level surface and chock the front wheels.

2

! DANGER

Failure to properly support the nose of the axle may result in the axle falling, which can cause serious injury or death to anyone near or under the vehicle.

Place a bottle jack under the axle flange to prevent the axle from rolling over.

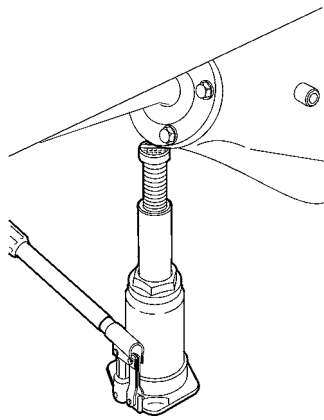

W7000752

Bottle jack

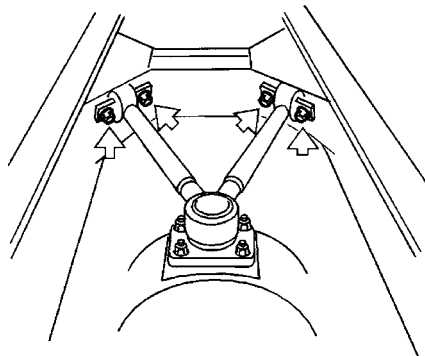

W6001320

3

Remove the four bolts that mount the V Torque Rod to the frame mounted bracket.

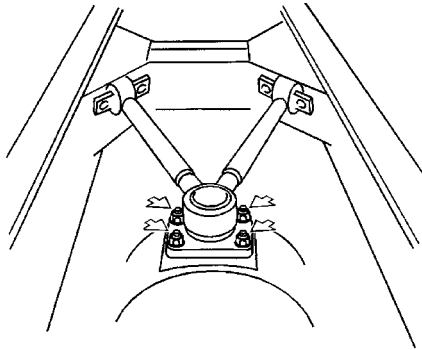

W6001321

4

Remove the four flange nuts that mount the V Torque Rod to the axle mounted torque rod bracket and cut any tie-straps or clippings from the V Torque Rod.

5

Using a lifting fixture, remove the V Torque Rod from the vehicle.

6

Set the replacement V Torque Rod in place by using a lifting fixture and line up the pins for proper alignment.

7

Start the flange nuts on the axle mounted bracket and torque them to 310 ± 30 Nm (229 ± 26 ft-lb).

310 ± 30 Nm (229 ± 26 ft-lb)

8

Start the bolts on the frame mounted bracket and torque them to 260 ± 30 Nm (192 ± 22 ft-lb).

260 ± 30 Nm (192 ± 22 ft-lb)

9

After starting all fasteners and tightening them to the proper torques, clip the electrical and pneumatic harness to the V Torque Rod.

10

Remove the bottle jack from underneath the axle flange and remove the wheel chocks.

6521-03-02-02

Torque/Radius Rod, Lower, Replacement

Please read "Guidelines for Working on the Volvo T-Ride Suspension" page 19 before beginning this procedure.

1

Park the vehicle on a level surface and chock the front wheels.

2

 **DANGER**

Failure to properly support the nose of the axle may result in the axle falling, which can cause serious injury or death to anyone near or under the vehicle.

Support the nose of the axle or axles being worked on with a bottle jack.

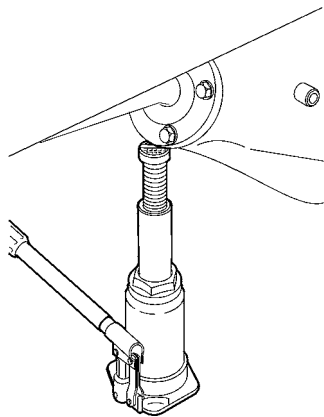

W7000752

Bottle jack

3

Remove the lower torque rod from between the rear axle mounting bracket and the saddle bracket.

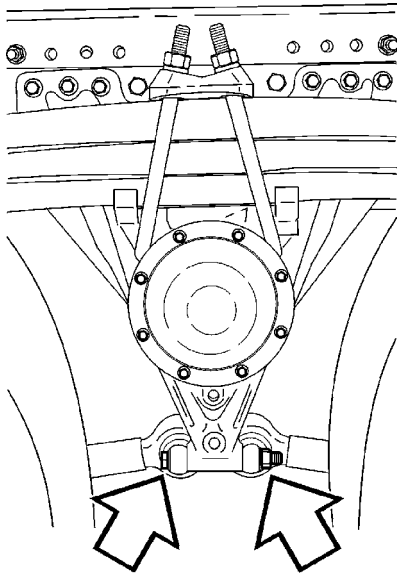

W6001355

4

Reinstall the torque rod back onto the truck and torque the bolts to 200 ± 25 Nm (148 ± 18 ft-lb).

Note: It may be necessary to loosen torque rods on both sides of the suspension for easier installation.

200 ± 25 Nm (148 ± 18 ft-lb)

7116-03-02-03 Bogie Anchorage Assembly, Replacement

Please read "Guidelines for Working on the Volvo T-Ride Suspension" page 19 before beginning this procedure.

1

Park the vehicle on a level surface and chock the front wheels.

2



Failure to support the nose of the axle may result in the axle falling, which can cause serious injury or death to anyone near or under the vehicle.

Support the nose of the axle or axles being worked on with a bottle jack.

3

Please refer to "Spring Assembly, Rear Leaf, Removal and Installation" page 30 for removing the Leaf Spring Assembly.

4

Please refer to "Cradle, Replacement" page 41 for removing the Cradle Assembly.

5

Remove the (2) bolts and nuts that connect the lower torque rods to the saddle bracket.

Note: It may be necessary to loosen the opposite sides of the saddle bracket to enable easier removal or installation, as well as proper wheel alignment during installation of the saddle bracket.

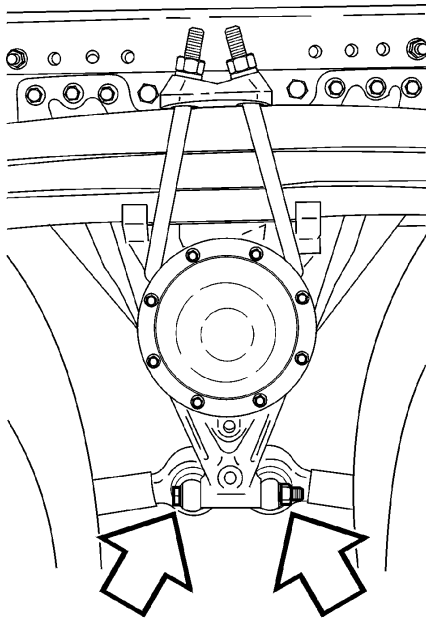

W6001355

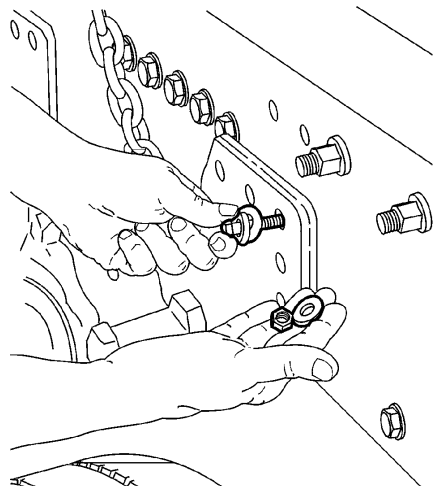

W6001325

Removing the saddle bracket bolts

6

Remove the saddle bracket bolts at the frame rail.

Note: At the top of the saddle bracket leave (1) bolt and nut attached loosely to each side to prevent it from falling off during removal.

7

Remove the saddle bracket bolts at the crossmember.

Note: These bolts are at the bottom side of the saddle bracket.

8

Hook a chain to the top two holes of the saddle bracket and use a lift or overhead crane to remove the saddle bracket.

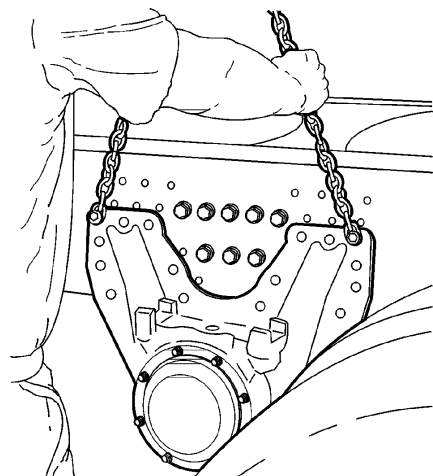

W6001324

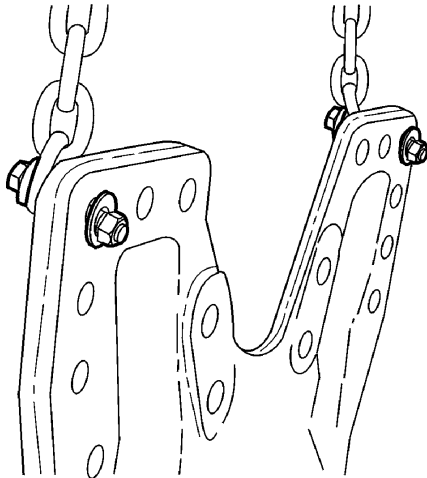

W6001326

9

For installation, hook a chain to the top two holes of the saddle bracket and use a lift or overhead crane to raise the saddle bracket into position.

10

Install the bolts to the saddle bracket at the crossmember and install the bolts to the saddle bracket at the frame rail and remove the chain. Torque the M14 bolts to 200 ± 30 Nm (148 ± 22 ft-lb) Nm to the frame and the M16 bolts to 320 ± 50 Nm (236 ± 37 ft-lb) to the frame and crossmember.

200 ± 30 Nm (148 ± 22 ft-lb),

320 ± 50 Nm (236 ± 37 ft-lb)

11

Install the (2) bolts that connect the lower torque rods to the saddle bracket and torque. For correct specifications please refer to "Tightening Torques" page 6 .

12

Refer to "Cradle, Replacement" page 41 for service procedures for installation of the Cradle Assembly.

13

Refer to "Spring Assembly, Rear Leaf, Removal and Installation" page 30 for installation of the Leaf Spring Assembly.

14

Check wheel alignment and remove wheel chocks.

Note: For wheel alignment refer to the proper service literature.

7116-03-02-01 V Torque Rod Anchorage, Replacement

Please read "Guidelines for Working on the Volvo T-Ride Suspension" page 19 before beginning this procedure.

1
Park the vehicle on a level surface, and chock the front wheels.

2
Using an air lift, raise the frame to relieve pressure from the suspension and support it with jack stands at the front and rear of the suspension.

3

! DANGER

Failure to properly support the nose of the axle may result in the axle falling, which can cause serious injury or death to anyone near or under the vehicle.

Place a bottle jack under the axle flange to prevent the axle from rolling over.

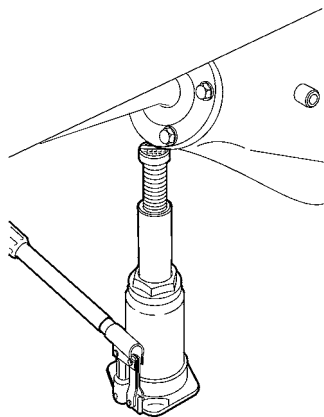

W7000752

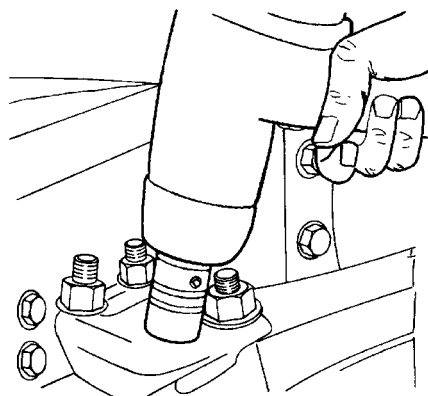

W6001312

Removing the U-bolts

4
Remove the (4) U-bolt nuts and remove the spring saddle cap.

5
With a lift or overhead crane remove the upper leaf springs.

6

Remove the (4) flange nuts that mount the rear V Torque rod to the axle mounted bracket and cut any clippings loose from the V Torque rod.

7

Remove the (4) bolts that mount the rear V Torque rod to the upper V Torque rod brackets and lift the rear V Torque rod out.

8

Remove the (2) bolts that mount the front V Torque rod to the upper V Torque rod bracket on the side of the vehicle being worked on.

9

Remove the bolts that mount the upper V Torque rod bracket to the frame rail and remove (2) bolts to the saddle bracket to assist in the removal of the upper V Torque rod bracket.

10

Once all bolts are removed, slide the upper V Torque rod bracket out from in between the frame and the crossmember.

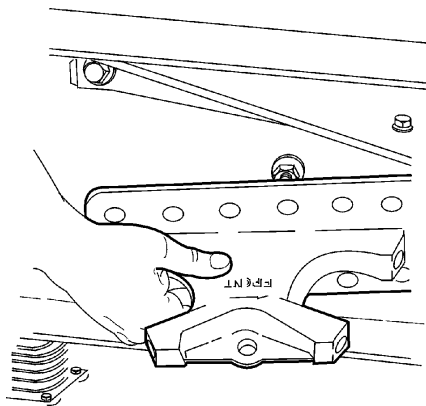

W6001323

11

Slide the replacement upper V Torque rod bracket into place and start all bolts. Torque M14 bolts to 200 ± 30 Nm (148 ± 22 ft-lb) and M16 bolts to 320 ± 50 Nm (236 ± 37 ft-lb).

Note: The upper V Torque rod bracket is marked with directional arrows for proper installation.

200 ± 30 Nm (148 ± 22 ft-lb)

320 ± 50 Nm (236 ± 37 ft-lb)

12

Set the V Torque rod into place and start the (4) bolts and (4) flange nuts. Torque the M16 bolts to 320 ± 50 Nm (236 ± 37 ft-lb) and the flange nuts to 310 ± 50 Nm (228 ± 37 ft-lb).

320 ± 50 Nm (236 ± 37 ft-lb)

310 ± 50 Nm (228 ± 37 ft-lb)

13

Install the leaf springs and spring saddle cap. Start U-bolts and tighten them to a torque of 500 ± 75 Nm (369 ± 55 ft-lb).

**CAUTION**

Do not reuse U-bolts.

Note: Make sure the leaf spring dowels and shims are lined up properly.

500 ± 75 Nm (369 ± 55 ft-lb)

7221-19-02-01 Spring Assembly, Rear Leaf, Removal and Installation

Please read "Guidelines for Working on the Volvo T-Ride Suspension" page 19 before beginning this procedure.

1

Park the vehicle on a level surface and chock the front wheels.

2

Using an air lift, raise the frame until the pressure is relieved from the leaf spring assembly.

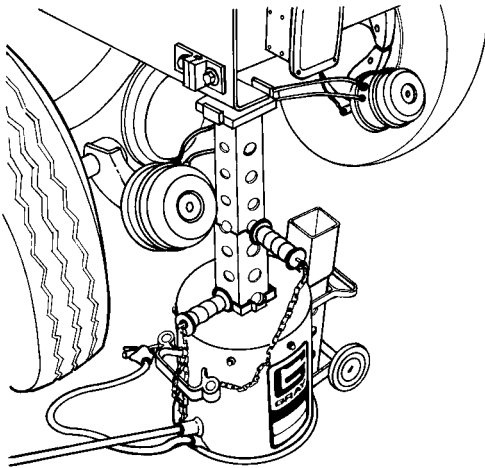

W7000269

Raising the frame

3

Support the frame with jack stands at the front and rear of the suspension.

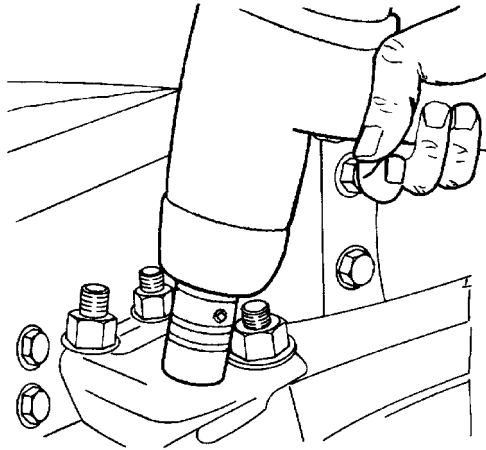

W6001312

Removing the spring U-bolt nuts

4

Remove the spring U-bolt nuts and then the leaf spring assembly saddle cap.

5

Remove the upper leaf springs using a lift or overhead crane.

Note: If there are several upper leaf springs it is best to remove them one at a time.

6

Remove the bolts to the spring plates on both ends of the lower leaf spring.

7

Using a lift or overhead crane, remove the lower leaf spring and remove the U-bolts.

Note: It may be necessary to rotate the cradle back and forth to remove the U-bolts.

8

Install the U-bolts and the lower leaf spring onto the cradle.

**CAUTION**

Do not reuse U-bolts.

Note: It may be necessary to rotate the cradle back and forth to install the U-bolts.

9

Once the lower leaf spring is in place, install the spring plates at both ends of the leaf spring and torque the bolts to 85 ± 15 Nm (63 ± 11 ft-lb).

85 ± 15 Nm
(63 ± 11 ft-lb)

10

Using a lift or overhead crane, install the remaining leaf springs.

Note: Be sure that all leaf springs are properly aligned and that all shims are installed properly.

Note: When replacing Parabolic Spring Leaves, the leaves on both sides should be replaced. When replacing the leaves, also insure that the leaves are marked with the same Camber Settings (+ or -).

11

Install the saddle cap and U-bolt nuts. Torque the U-bolt nuts to 500 ± 75 Nm. Torque all U-bolt nuts to 10 Nm before applying the full amount of torque.

500 ± 75 Nm (369 ± 55 ft-lb)

12

Raise the frame and remove the jack stands, then lower the frame and remove the wheel chocks.

7221-03-02-03 Rear Spring Leaf, Replacement

Please read "Guidelines for Working on the Volvo T-Ride Suspension" page 19 before beginning this procedure.

1
Park the vehicle on a level surface and chock the front wheels.

2
Remove the nuts from the spring ends.

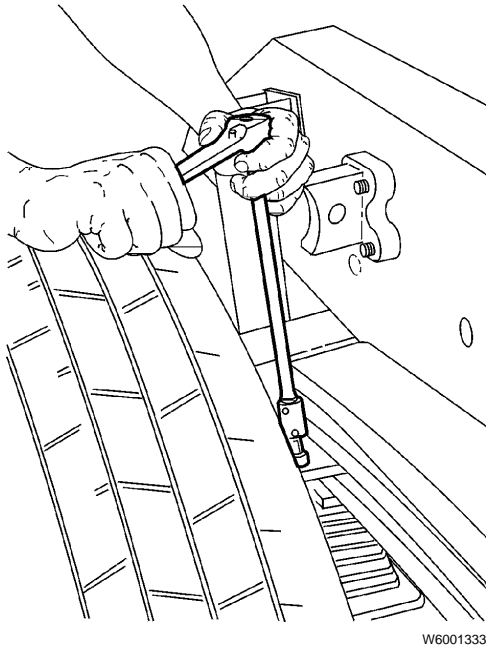

W6001333
Removing the spring end nuts.

3
Raise the frame and support the frame rails with jack stands, one at the front and one at the rear of the rear suspension.

4
Remove the spring U-bolt nuts and then the spring saddle cap.

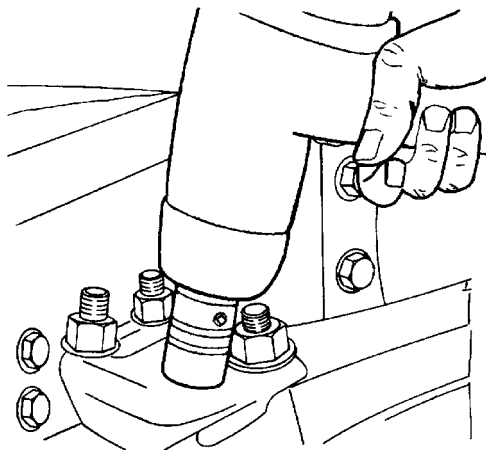

W6001312
Removing the U-bolt nuts

5

Use an overhead crane or other approved lifting devices to remove the spring assembly.

6

Dismantle spring leaf assembly and remove the damaged spring leaf.

7

Inspect the shims between the spring leaves and replace them if they are damaged.

8

Install the new spring leaf or leaves and reassembly the spring assembly.

Note: When replacing Parabolic Spring Leaves, the leaves on both sides should be replaced. When replacing the leaves, also insure that the leaves are marked with the same Camber Settings (+ or -).

9

To reinstall the spring assembly, reverse procedures 1 through 4.

10

Torque U-bolt nuts to 500 ± 75 Nm (370 ± 55 ft-lb).
Torque top spring end nuts to 144 ± 31 Nm (107 ± 23 ft-lb). Torque bottom spring end nuts to 260 ± 30 Nm (192 ± 22 ft-lb).

500 ± 75 Nm (370 ± 55 ft-lb)
 144 ± 31 Nm (107 ± 23 ft-lb) ,
 260 ± 30 Nm, (192 ± 22 ft-lb)

7271-03-02-01 Rubber Spring, Replacement (Each)

Please read "Guidelines for Working on the Volvo T-Ride Suspension" page 19 before beginning this procedure.

- 1**
Park the vehicle on a level surface and chock the front wheels.
- 2**
Remove the four Allen fasteners from the spring plate.

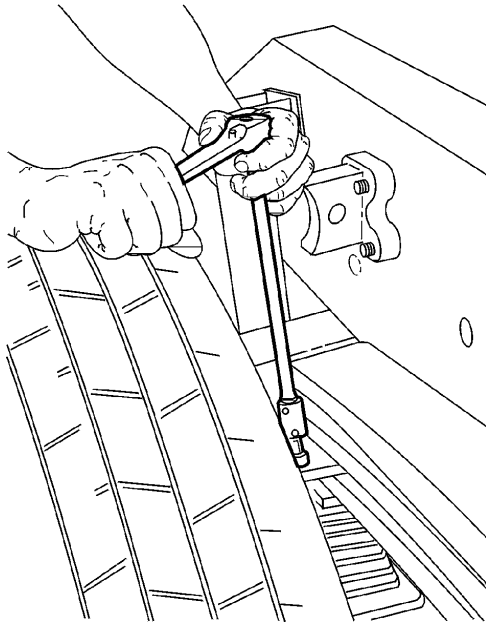

W6001333

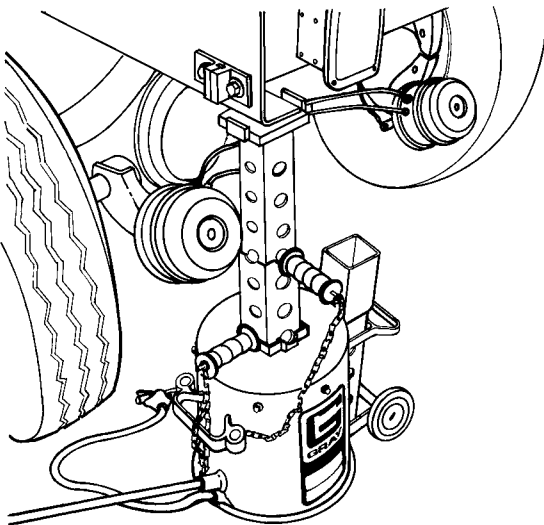

Raising the frame

W7000269

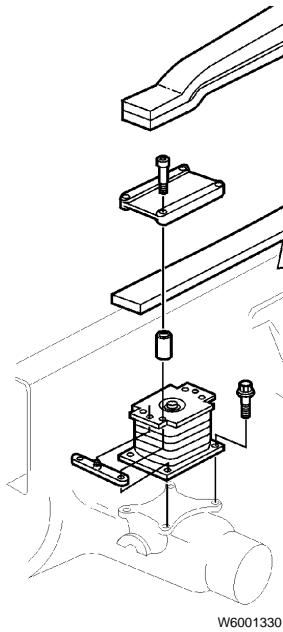
**4**

Remove the four fasteners that mount the rubber spring to the axle mounted bracket and remove the rubber spring.

5

Install the replacement rubber spring onto the axle mounted bracket and torque the fasteners to 140 ± 25 Nm (103 ± 18 ft-lb).

140 ± 25 Nm (103 ± 18 ft-lb)

6

Lower the frame slowly while sliding the spring plate back into position.

7

Once the spring plate is in position, install the Allen head fasteners and torque them to 85 ± 15 Nm (63 ± 11 ft-lb).

85 ± 15 Nm
(63 ± 11 ft-lb)

8

Lower the frame completely and remove the wheel chocks.

9

Torque top spring end nuts to 144 ± 31 Nm (107 ± 23 ft-lb). Torque bottom spring end nuts to 260 ± 30 Nm (192 ± 22 ft-lb).

144 ± 31 Nm (107 ± 23 ft-lb)
 260 ± 30 Nm (192 ± 22 ft-lb)

10

Torque bolts for rubber spring to axle pads as follows:

- VOLVO — 115 ± 25 Nm (85 ± 18 ft-lb).
- Rockwell/Eaton — 73 ± 17 Nm (54 ± 13 ft-lb).

115 ± 25 Nm (85 ± 18 ft-lb),
 73 ± 17 Nm (54 ± 13 ft-lb)

7229-03-02-01 Rear Spring Retaining Bolt, Replacement

Please read "Guidelines for Working on the Volvo T-Ride Suspension" page 19 before beginning this procedure.

1
Park the vehicle on a level surface and chock the front wheels.

2
Remove the spring U-bolt nuts and then the spring saddle cap.

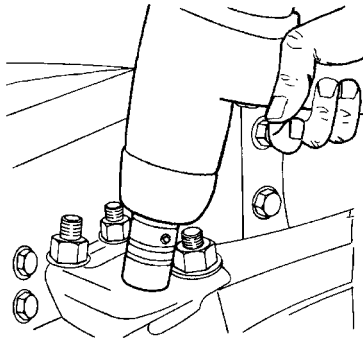

W6001312

Removing the U-bolt nuts

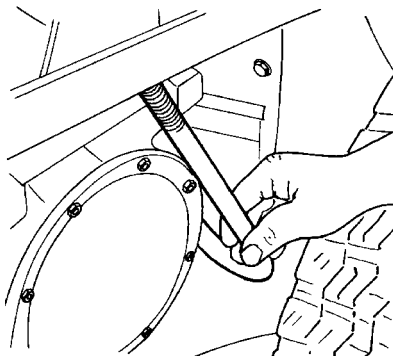

W6001314

Removing the U-bolts

3
Remove the spring U-bolts.

4
To facilitate the U-bolt removal, rotate the cradle to the left and right, and slide the U-bolt out.

 **CAUTION**

Do not reuse U-bolts.

5
To reassemble with new U-bolts, reverse procedures 1 through 3.

6

Torque U-bolt nuts to 500 ± 75 Nm (370 ± 55 ft-lb).

Note: If there are several upper leaf springs it is best to remove them one at a time.

500 ± 75 Nm (370 ± 55 ft-lb)

6559-05-02-01 Tandem, Alignment

Please read "Guidelines for Working on the Volvo T-Ride Suspension" page 19 before beginning this procedure.

To align the tandem use the J36795, Tandem Axle Calipers. Tandem adjustments are made with washer shims that are fastened to the saddle bracket at the lower torque rod end.

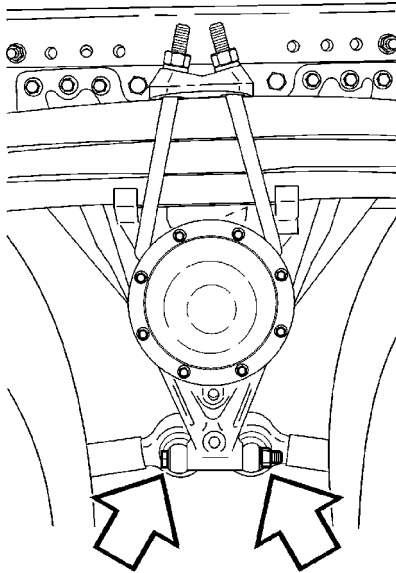

W6001355

Fig. 2: Bogie Bracket and Tandem alignment

1

To remove or install washer shims, remove the long through bolts that hold both the front and the rear lower torque rod ends at the saddle bracket.

2

After installing or removing shims, re-torque bolt nuts to 200 ± 25 Nm (148 ± 18 ft-lb).

200 ± 25 Nm (148 ± 18 ft-lb)

3

Refer to the correct service literature for alignment procedures.

6553-03-02-03 Cradle, Replacement

Please read "Guidelines for Working on the Volvo T-Ride Suspension" page 19 before beginning this procedure.

1
Park vehicle on a level surface and the chock front wheels.

2
Using an air lift raise the frame and support it with jack stands at the front and back of the suspension.

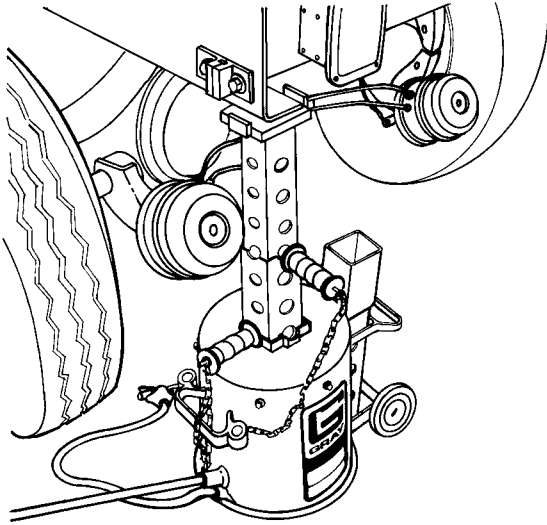

W7000269

Raising the frame

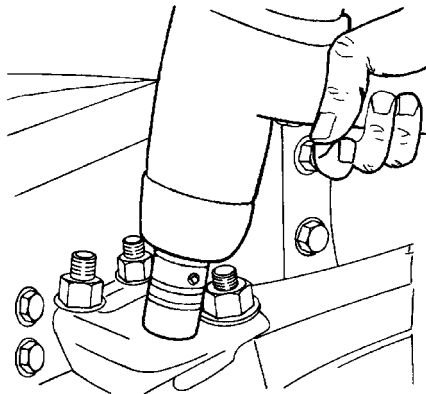

W6001312

Removing the U-bolts

3
Once the frame is supported and the suspension is relieved of pressure, remove the four U-bolt nuts and remove the spring saddle cap.

4
Using a lifting device, remove the upper leaf springs

Note: If there are several upper leaf springs it is best to remove them one at a time.

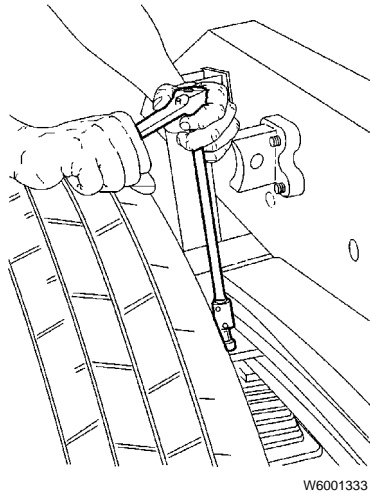
**5**

After removing the upper leaf springs, remove the spring plate on each end of the lower leaf spring to enable to removal of the lower leaf spring.

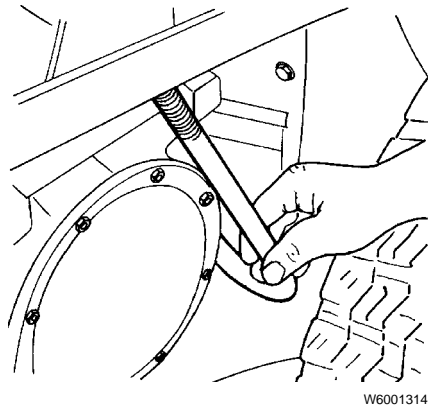
**6**

Remove the lower leaf spring and remove the U-bolts from the cradle.

Note: It may be necessary to rotate the cradle back and forth to remove the U-bolts.

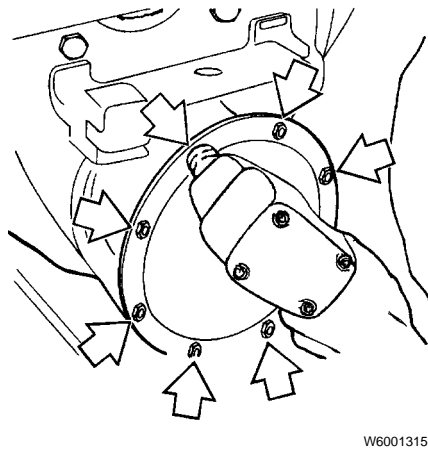
**7**

Remove the hub cap from the cradle and clean off the grease from around the snap ring.

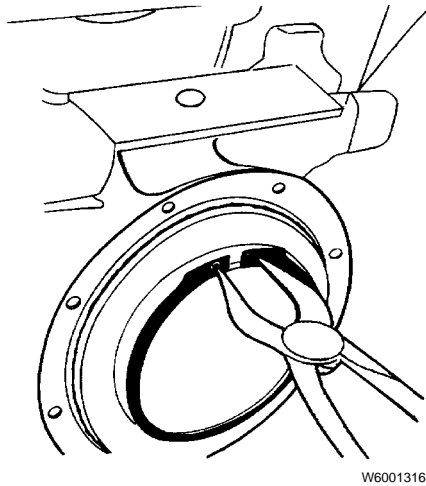

W6001316

Removing the snap ring

8

Using snap-ring pliers, remove the snap ring.

**WARNING**

Always wear eye protection when working around batteries to prevent the risk of injury due to contact with sulfuric acid or explosion.

9988185

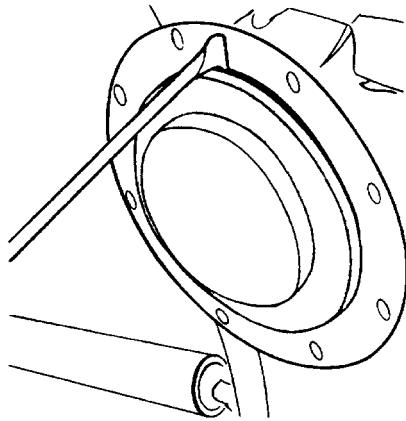

W6001319

Removing the outer thrust washer

9

Using VOLVO tool 9992337 remove the outer thrust washer.

9992337

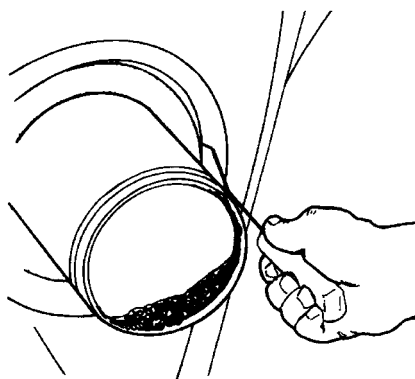

W6001317

Removing the outer thrust washer

10

Slide the cradle off from the trunnion tube and remove the inner thrust washer. Use Snap-On tool number A173 to remove the inner thrust washer.

A173

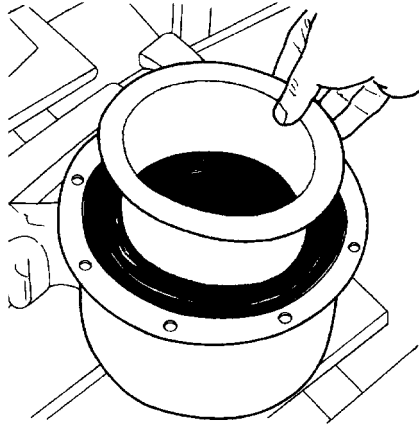

W6001318

11

Remove the nylon bushings from the cradle. For grease seal replacement, see service procedures for grease seals replacement.

Note: Use a generous amount of grease when replacing grease seals.

12

Install the inner thrust washer and nylon bushing's by sliding the cradle on to the trunnion tube.

13

Install the outer thrust washer and snap ring.

Note: It is recommended to use a new snap ring when replacing cradle seals or grease seals. Make sure the snap ring is fully seated.

14

Install the hub cap and torque the bolts to 20 ± 5 Nm (15 ± 4 ft-lb).

20 ± 5 Nm
(15 ± 4 ft-lb)

15

Reverse the procedures (steps 1–5) for installing the leaf spring assembly. Torque U-bolt nuts to 500 ± 75 Nm (369 ± 55 ft-lb). Torque the spring plate bolts to 85 ± 15 Nm (63 ± 11 ft-lb).

**CAUTION**

Do not reuse U-bolts

500 ± 75 Nm (369 ± 55 ft-lb)
 85 ± 15 Nm (63 ± 11 ft-lb)

16

Remove the jack stands and wheel chocks.

6559-03-04-01

Grease Seals, Replacement

(Cradle Removed)

Please read "Guidelines for Working on the Volvo T-Ride Suspension" page 19 before beginning this procedure.

Cradle Removed

1

Remove the old grease seals from the cradle.

2

Clean out the seal grooves and lightly smear clean grease over grooves.

3

Install new grease seals. The larger of the two grease seals fits on the inside groove and the smaller one fits on the outer groove. The grease seal lips face each other when in position.

4

Lightly apply grease on both seals.

5

Remove the wear ring from the cavity in the saddle bracket and install a new wear ring. This wear ring can be removed using a flat blade screwdriver.

6

Reinstall the cradle back onto the trunnion tube.

6559-10-02-01 Cradle Bearing, Lubrication

Please read "Guidelines for Working on the Volvo T-Ride Suspension" page 19 before beginning this procedure.

It is important that lubrication is done as follows so the bearing is filled completely with grease.

1

Remove pressure relief valve located at "A" and install a grease fitting.

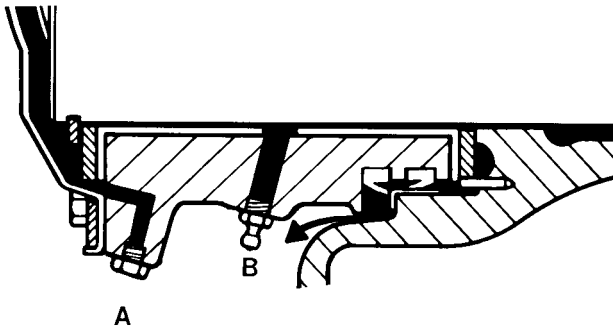

W7000264

Cradle bearing lubrication points

2

Remove the grease fitting at "B".

3

Fill with grease through "A" fitting until grease oozes out of "B".

4

Install grease fitting at "B" and fill with grease until it oozes out around the entire seal (see arrow).

5

Remove grease fitting at "A" and reinstall the pressure relief valve.

7113-01-01-01 Permanent Fastener, Removal

You must read and understand the precautions and guidelines in Service Information, Group 70, "General Safety Practices" before performing this procedure. If you are not properly trained and certified in this procedure, ask your supervisor for training before you perform it.

The HUCKBOLT® Permanent fasteners are "swagged" over the grooved pin. No amount of twisting or hammering will dislodge or remove the pin from the collar. The collar must be cut parallel to the HUCKBOLT® pin end of the swagged section. This is best accomplished with a small wheel grinder. Other options may be to use a drill or chisel to create openings on the collar wall.

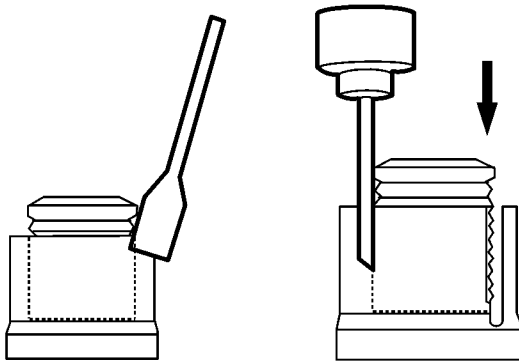

W7001282

Fig. 3: Optional collar removal procedures



CAUTION

HUCKBOLT® Permanent Fasteners are clamped at a very high torque and they may release suddenly. Wear proper eye protection and keep your face at least two feet away from the collar. **Do not use a cutting torch for removal.**

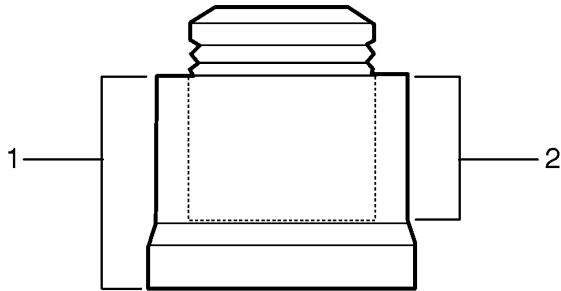

W7001283

- 1 Collar section
- 2 Swagged section

1

Using a wheel grinder (preferred method) cut a vertical groove into the "swagged" section of the HUCKBOLT® collar on two or more sides (see arrow in figure 1).

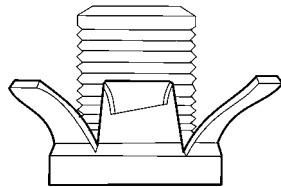

W7001274

2

After the collar is opened over the length of the swagged portion on two or more opposing sides, the pin may become free. If not, additional collar material should be pulled away from the swagged section of the collar using vice grips or a chisel.

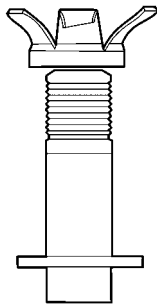

W7001276

3

Remove the pin after sufficient material is pulled away from the swagged section of the collar.

Note: Any fastener that is removed should be replaced with a fastener of equal or greater strength.

Note: For HUCKBOLT® Installation procedures refer to Service Information in Group 711 "HUCKBOLT® Tool, Repair procedure".

VOLVO

Volvo Trucks North America, Inc.

P.O. Box 26115, Greensboro, NC 27402-6115

Volvo Trucks Canada, Ltd.

5600A Cancross Court, Mississauga, Ontario L5R 3E9

<http://www.volvotrucks.volvo.com>