

EHX\*E Series  
Explosion-Proof  
Camera Enclosure

Maintenance/  
Service Manual

C417SM (7/99)



Pelco • 300 W. Pontiac Way, Clovis • CA 93612-5699 USA • Pelco Online @ <http://www.pelco.com>  
In North America and Canada: Tel (800) 289-9100 or FAX (800) 289-9150 • DataFAX (800) 289-9108  
International Customers: Tel (1-559) 292-1981 or FAX (1-559) 348-1120 • DataFAX (1-559) 292-0435

## IMPORTANT SAFEGUARDS AND WARNINGS

Prior to installation and use of this product, the following WARNINGS should be observed.

1. Installation and servicing should only be done by qualified service personnel and conform to all local codes.
2. Only use replacement parts recommended by Pelco.
3. The installation method and materials should be capable of supporting four times the weight of the enclosure, pan/tilt, camera and lens combination.
4. The camera and lens combination shall not exceed 20 lb (9.06 kg).
5. For marine applications, the installation shall be in accordance with the Electrical Engineering Regulations of the USCG, Subpart J, C.G. 259 (46 CFR Parts 110-113).
6. This enclosure has not been evaluated for use on vessels less than 65 feet (19.81 m) long.

The product and/or manual may bear the following marks:



This symbol indicates that dangerous voltage constituting a risk of electric shock is present within this unit.



This symbol indicates that there are important operating and maintenance instructions in the literature accompanying this unit.

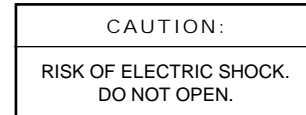

Please thoroughly familiarize yourself with the information in this manual prior to installation and operation.

## DESCRIPTION

The EHX\*E Series of non-pressurized, explosion-proof camera enclosures is designed to meet the rigorous requirements of explosion-proof and dust-ignition-proof electrical equipment for installation and use in hazardous locations.

## MODELS

*NOTE: Dimensions referenced are inside dimensions.*

EHX4E	Explosion-proof, non-pressurized enclosure, 4-inch (10.16 cm) diameter x 12-inch (30.48 cm) length.
EHX6E	Explosion-proof, non-pressurized enclosure, 6-inch (15.24 cm) diameter x 24-inch (60.96 cm) length.
EHX6E-16	Same as EHX6E except 16-inch (40.64 cm) length.
EHX8E	Explosion-proof, non-pressurized enclosure, 8-inch (20.32 cm) diameter x 24-inch (60.96 cm) length.
EHX10E	Explosion-proof, non-pressurized enclosure, 10-inch (25.40 cm) diameter x 24-inch (60.96 cm) length.

## MAINTENANCE

Regularly scheduled maintenance will help prolong the operational life and appearance of the equipment.

1. Periodically look inside the window of the enclosure and check the indicator on the roof. Lavender indicates normal at the desired humidity level. Pink indicates excessive dampness; blue indicates dryness. For example, if you want to maintain a humidity level of 20%, the 20% dot should be lavender.

- Inspect the sealing fittings frequently for the condition of the sealant.

A service kit containing a rear O-ring and four rear plate mounting screws is included with the enclosure. Use these spare parts if the original parts are damaged or lost during maintenance or repair of the enclosure. Each enclosure has its own O-ring kit: EHX4EKIT, EHX6EKIT, EHX8EKIT, EHX10EKIT.

## EXPLODED ASSEMBLY DIAGRAMS

**WARNING:** Do not remove the front cover. If you do, Pelco cannot be held responsible for the loss of explosion-proof rating, UL listing, or ability of the enclosure to contain an explosion.

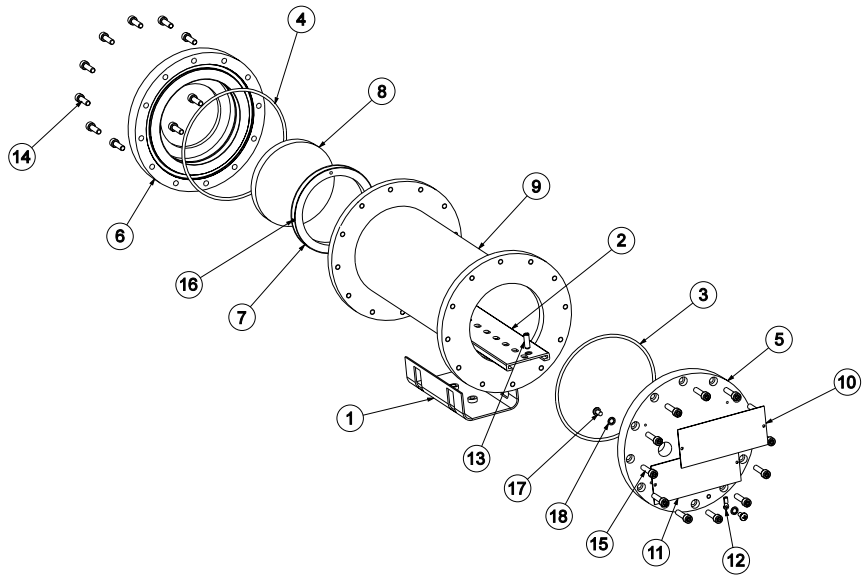
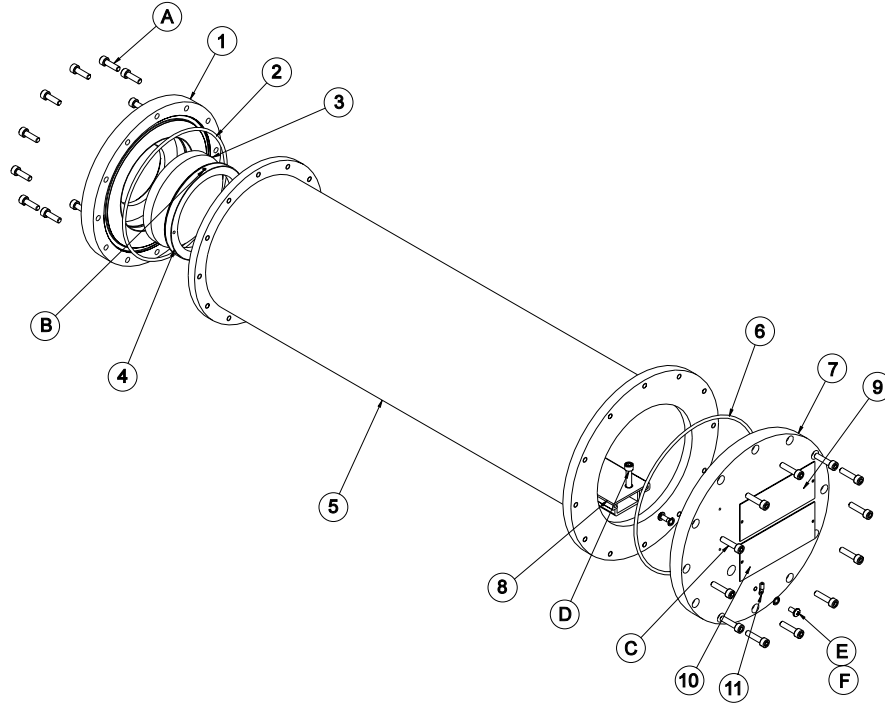

Figure 1. EHX4E Exploded Assembly Diagram

Table A. EHX4E Exploded Assembly Parts List

Item	Quantity	Description	Part Number
1	1	Cradle	E7044003COMP
2	1	Camera sled	EH40104001COMP
3	1	O-ring, UL approved	EHX410002
4	1	O-ring, UL approved	EHX410003
5	1	Rear plate	EHX44002COMP
6	1	Window retainer, female thread	EHX44296COMP
7	1	Window retainer, male thread	EHX44297COMP
8	1	Glass window, 4.250" diameter x .475" thick	EHX4E10089
9	1	Body assembly	EHX4E121000WA
10	1	Warning label	LBLPELCOEHX-4E
11	1	Global certification label	LBLULEHX-E
12	1	Terminal lug	TB02-9221-6211
13	1	Set screw, 1/4-20 x 3/4"	ZH1/420X.750S
14	12	Screw, 6mm x 20mm, 1P, socket head, heat-treated steel, Dacromet	ZH6.0X1.0X20CS
15	12	Screw, 6mm x 25mm, 1P, socket head, heat-treated steel, Dacromet	ZH6.0X1.0X25CS
16	2	6-32 x 3/8" nylon tip set screw	ZH6-32X.375SSN
17	2	Screw, 10-32 x 3/8", pan head, Phillips	ZH10-32X.375SPP
18	2	Internal tooth lock washer, #10	ZH10LWSIS
NS	1	Pipe plug	ZHPLUG1/2NPT
NS	4	Drive screw, #4 x 3/16"	ZH4X3/16DRVRVT
NS	2	Cradle and shroud strap	E7044004COMP
NS	2	Nipple	EHX82410083
NS	2	Gland	EHX82410084
NS	2	Pelco label	LBLG10020

NS = Not shown

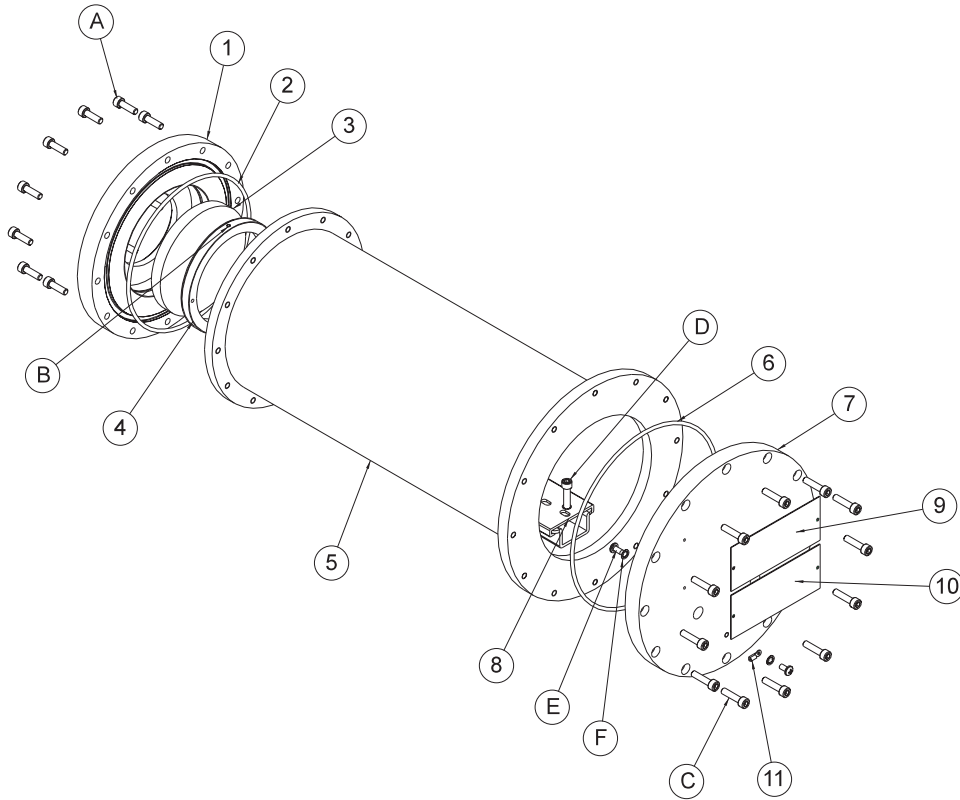

**Figure 2.** EHX6E Exploded Assembly Diagram

**Table B.** EHX6E Exploded Assembly Parts List

Item	Quantity	Description	Part Number
1	1	Window retainer, female thread	EHX64296COMP
2	1	O-ring, UL approved	EHX610001
3	1	Glass window, 4-1/2" diameter x 1/2" thick	EHX410088
4	1	Window retainer, male thread	EHX64297COMP
5	1	Body assembly	EHX6E241000WA
6	1	O-ring, UL approved	EHX810001
7	1	Rear plate	EHX64002COMP
8	1	Camera sled	EHD104000COMP
9	1	Warning label	LBLPELCOEHX-6E
10	1	Global certification label	LBLULEHX-E
11	1	Terminal lug	TB02-9221-6211
A	12	Screw, 6mm x 20mm, 1P, socket head, heat-treated steel, Dacromet	ZH6.0X1.0X20CS
B	2	6-32 x 3/8" nylon tip set screw	ZH6-32X.375SSN
C	12	Screw, 6mm x 25mm, 1P, socket head, heat-treated steel, Dacromet	ZH6.0X1.0X25CS
D	1	Allen screw, 1/4-20 x 1.00"	ZH1/420X1.00SS
E	2	Screw, 10-32 x 3/8", pan head, Phillips	ZH10-32X.375SPP
F	2	Internal tooth lock washer, #10	ZH10LWSIS
NS	1	Cradle	EHD74258COMP
NS	2	Cradle strap	EHX6244168COMP
NS	2	Nipple	EHX82410083
NS	2	Gland	EHX82410084
NS	2	Pelco label	LBLG10010
NS	1	Pipe plug	ZHPLUG1/2NPT

NS = Not shown

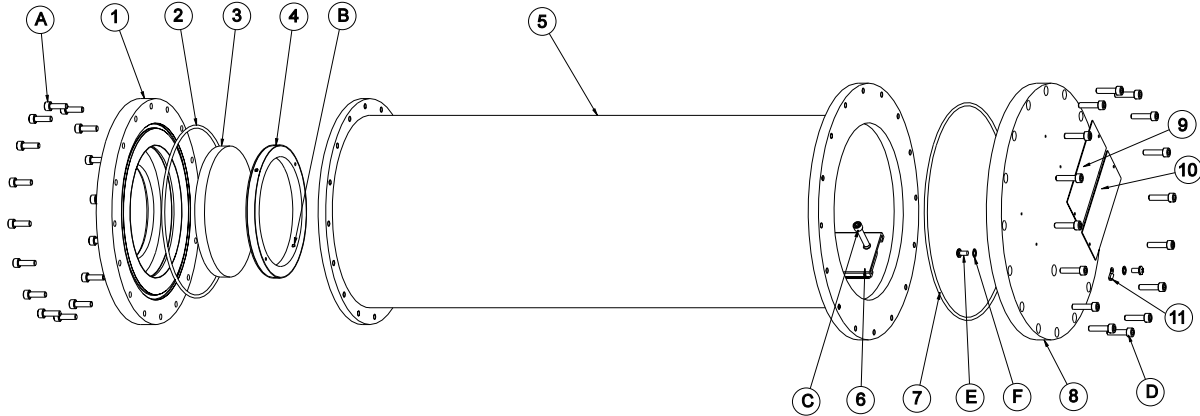

**Figure 3.** EHX6E-16 Exploded Assembly Diagram

**Table C.** EHX6E-16 Exploded Assembly Parts List

Item	Quantity	Description	Part Number
1	1	Window retainer, female thread	EHX64296COMP
2	1	O-ring, UL approved	EHX610001
3	1	Glass window, 4-1/2" diameter x 1/2" thick	EHX410088
4	1	Window retainer, male thread	EHX64297COMP
5	1	Body assembly	EHX6E161000WA
6	1	O-ring, UL approved	EHX810001
7	1	Rear plate	EHX64002COMP
8	1	Camera sled	EH40144001COMP
9	1	Warning label	LBLPELCOEHX6E16
10	1	Global certification label	LBLULEHX-E
11	1	Terminal lug	TB02-9221-6211
A	12	Screw, 6mm x 20mm, 1P, socket head, heat-treated steel, Dacromet	ZH6.0X1.0X20CS
B	2	6-32 x 3/8" nylon tip set screw	ZH6-32X.375SSN
C	12	Screw, 6mm x 25mm, 1P, socket head, heat-treated steel, Dacromet	ZH6.0X1.0X25CS
D	1	Allen screw, 1/4-20 x 1.00"	ZH1/420X1.00SS
E	2	Screw, 10-32 x 3/8", pan head, Phillips	ZH10-32X.375SPP
F	2	Internal tooth lock washer, #10	ZH10LWSIS
NS	1	Cradle	EHD74258COMP
NS	2	Cradle strap	EHX6244168COMP
NS	2	Nipple	EHX82410083
NS	2	Gland	EHX82410084
NS	2	Pelco label	LBLG10010
NS	1	Pipe plug	ZHPLUG1/2NPT

NS = Not shown

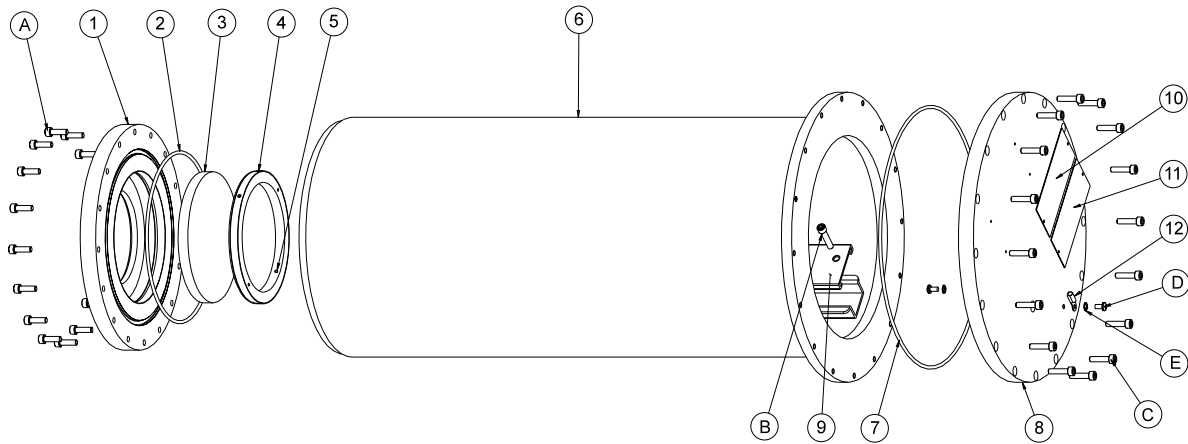

**Figure 4.** EHX8E Exploded Assembly Diagram

**Table D.** EHX8E Exploded Assembly Parts List

Item	Quantity	Description	Part Number
1	1	Window retainer, female thread	EHX104296COMP
2	1	O-ring, UL approved	EHX810001
3	1	Glass window, 5-7/8" diameter x 1/2" thick	EHX810088
4	1	Window retainer, male thread	EHX104297COMP
5	1	Body assembly	EHX8241000WA
6	1	Camera sled	EHD104000COMP
7	1	O-ring, UL approved	EHX810003
8	1	Rear plate	EHX8244298COMP
9	1	Warning label	LBLPELCOEHX-8E
10	1	Global certification label	LBLULEHX-E
11	1	Terminal lug	TB02-9221-6211
A	16	Screw, 6mm x 20mm, 1P, socket head, heat-treated steel, Dacromet	ZH6.0X1.0X20CS
B	2	6-32 x 3/8" nylon tip set screw	ZH6-32X.375SSN
C	1	Allen screw, 1/4-20 x 1.25"	ZH1/420X1.25CS
D	16	Screw, 6mm x 25mm, 1P, socket head, heat-treated steel, Dacromet	ZH6.0X1.0X25CS
E	2	Screw, 10-32 x 3/8", pan head, Phillips	ZH10-32X.375SPP
F	2	Internal tooth lock washer, #10	ZH10LWSIS
NS	1	Cradle	EHD94270COMP
NS	2	Cradle strap	EHX8244166COMP
NS	2	Nipple	EHX82410083
NS	2	Gland	EHX82410084
NS	2	Pelco label	LBLG10010
NS	1	Pipe plug	ZHPLUG1/2NPT

NS = Not shown



**Figure 5.** EHX10E Exploded Assembly Diagram

**Table E.** EHX10E Exploded Assembly Parts List

Item	Quantity	Description	Part Number
1	1	Window retainer, female thread	EHX104296COMP
2	1	O-ring, UL approved	EHX810001
3	1	Glass window, 5-7/8" diameter x .1/2" thick	EHX810088
4	1	Window retainer, male thread	EHX104297COMP
5	2	6-32 x 3/8" nylon tip set screw	ZH6-32X.375SSN
6	1	Body assembly	EHX10E241000WA
7	1	O-ring, UL approved	EHX1010000
8	1	Rear plate	EHX104002COMP
9	1	Camera sled	EHD104000COMP
10	1	Warning label	LBLPELCOEHX-E
11	1	Global certification label	LBLULEHX-E
12	1	Terminal lug	TB02-9221-6211
A	16	Screw, 6mm x 20mm, 1P, socket head, heat-treated steel, Dacromet	ZH6.0X1.0X20CS
B	1	Allen screw, 1/4-20 x 1.25"	ZH1/420X1.25CS
C	16	Screw, 6mm x 25mm, 1P, socket head, heat-treated steel, Dacromet	ZH6.0X1.0X25CS
D	2	Screw, 10-32 x 3/8", pan head, Phillips	ZH10-32X.375SPP
E	2	Internal tooth lock washer, #10	ZH10LWSIS
NS	1	Cradle	EHD94270COMP
NS	2	Cradle strap	EHX10244169COMP
NS	2	Nipple	EHX82410083
NS	2	Gland	EHX82410084
NS	2	Pelco label	LBLG10010
NS	1	Pipe plug	ZHPLUG1/2NPT

NS = Not shown

## WARRANTY AND RETURN INFORMATION

### WARRANTY

Pelco will repair or replace, without charge, any merchandise proved defective in material or workmanship for a period of one year after the date of shipment. Exceptions to this warranty are as noted below:

- Three years on Genex™ Series (multiplexers, server, and keyboard).
- Two years on all standard motorized and fixed focal length lenses.
- Two years on Esprit™, Legacy®, Intercept®, PV1000 Series, CM6700/CM8500/CM9500/CM9750/CM9760 Matrix, Spectra®, DF5 Series and DF8 Fixed Dome products.
- Two years on WW5700 series window wiper (excluding wiper blades).
- Two years on cameras.
- Six months on all pan and tilts, scanners or preset lenses used in continuous motion applications (that is, preset scan, tour and auto scan modes).

Pelco will warrant all replacement parts and repairs for 90 days from the date of Pelco shipment. All goods requiring warranty repair shall be sent freight prepaid to Pelco, Clovis, California. Repairs made necessary by reason of misuse, alteration, normal wear, or accident are not covered under this warranty.

Pelco assumes no risk and shall be subject to no liability for damages or loss resulting from the specific use or application made of the Products. Pelco's liability for any claim, whether based on breach of contract, negligence, infringement of any rights of any party or product liability, relating to the Products shall not exceed the price paid by the Dealer to Pelco for such Products. In no event will Pelco be liable for any special, incidental or consequential damages (including loss of use, loss of profit and claims of third parties) however caused, whether by the negligence of Pelco or otherwise.

The above warranty provides the Dealer with specific legal rights. The Dealer may also have additional rights, which are subject to variation from state to state.

If a warranty repair is required, the Dealer must contact Pelco at (800) 289-9100 or (559) 292-1981 to obtain a Repair Authorization number (RA), and provide the following information:

1. Model and serial number
2. Date of shipment, P.O. number, Sales Order number, or Pelco invoice number
3. Details of the defect or problem

If there is a dispute regarding the warranty of a product which does not fall under the warranty conditions stated above, please include a written explanation with the product when returned.

Ship freight prepaid to: Pelco  
300 West Pontiac Way  
Clovis, CA 93612-5699

Method of return shipment shall be the same or equal to the method by which the item was received by Pelco.

### RETURNS

In order to expedite parts returned to the factory for repair or credit, please call the factory at (800) 289-9100 or (559) 292-1981 to obtain an authorization number (CA number if returned for credit, and RA number if returned for repair). Goods returned for repair or credit should be clearly identified with the assigned CA/RA number and freight should be prepaid. All merchandise returned for credit may be subject to a 20% restocking and refurbishing charge.

Ship freight prepaid to: Pelco  
300 West Pontiac Way  
Clovis, CA 93612-5699

### REVISION HISTORY

Manual #	Date	Comments
C417SM	9/98	Original version.
	7/99	Removed blower and heater kit information.