

SPECIAL PURPOSE CUTTER

USERS GUIDE TO:
 INFORMATION, ASSEMBLY, OPERATION, MAINTENANCE
 PARTS

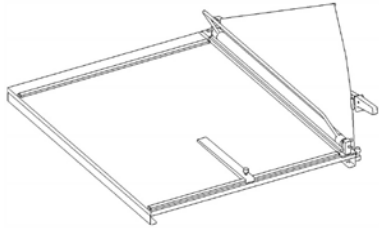

| | | |
|---------------------|---------------------|---------------------|
| Model #142 | Model #136 | Model #130 |
| Cutting Length: 42" | Cutting Length: 36" | Cutting Length: 30" |

THE QUALITY IS BUILT IN

Dahle Cutters are recognized the world over as the finest in precision cutting. These high quality cutters have been carefully engineered to provide years of service with a minimum of maintenance. Dahle Cutters use only the highest quality Solingen Steel blades, ground and tempered to exacting standards. Each cutter has been carefully assembled and tested to meet Dahle's highest standards.

For more information about Dahle products contact ABC Office at 1-800-658-8788.

WARRANTY

NOTE: Unless the Warranty Card is properly and promptly filled out and mailed, you will not be protected under the warranty terms.

Dahle USA warrants each new Cutter to be free from defects in material and workmanship for a period of one year after the original purchase under normal use and service. Each machine will be thoroughly inspected by us before shipment to ensure perfect condition. We agree to repair or replace any such defective unit or parts, at our discretion, provided the defective unit or parts are returned to us intact, transportation prepaid, within the guarantee period, and that our examination disclosed to our satisfaction that the unit is defective. This warranty shall not apply to any cutter or part thereof which has been repaired or altered in any way, so as, in our judgment, to affect their reliability or stability, nor which have been subject to misuse, negligence, or accident.

THIS WARRANTY is expressly in lieu of all other warranties expressed or implied, and the manufacturer neither assumes or authorize any representative or other person to assume for it, any other liability in connection with sale, maintenance, or repair of said cutter.

NO CUTTER is to be returned to us for any reason without our permission and return merchandise authorization (RMA) number.

DAHLE USA whose policy is one of continued product improvement, reserves the right to make changes in design and the construction at any time without incurring any obligation on cutters previously sold.

ASSEMBLY

When assembling or moving your Cutter, remember the **BLADE IS SHARP**. Keep the blade closed when handling or moving the Cutter. After positioning the Cutter, install the Guard before using the Cutter. **THE BLADE GUARD IS FOR YOUR PROTECTION.**

INSTALLING GUARD

The Guard is installed with the blade closed. Place the guard between the Blade and the Hold-down, small end to the rear of the Cutter. The large end of the Guard should rest in the guide on the blade near the handle. Install **fully threaded screw** through the Hold-down post at the rear of the Cutter and tighten with the proper screw driver.

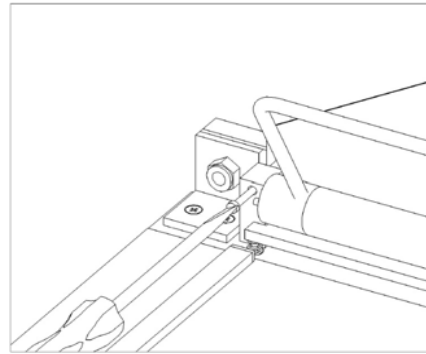

Install the **threaded pin** through the front Hold-down post and again tighten with screw driver. The Cutter Blade should open and close without binding.

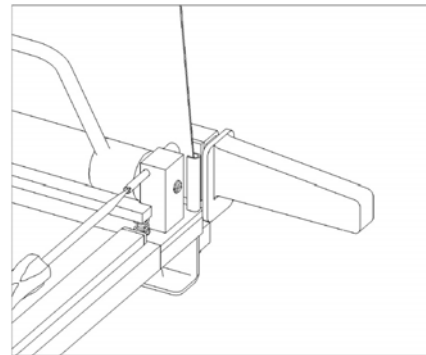

HOLD DOWN SYSTEM

The material hold-down system should be used by applying and holding pressure while cutting.

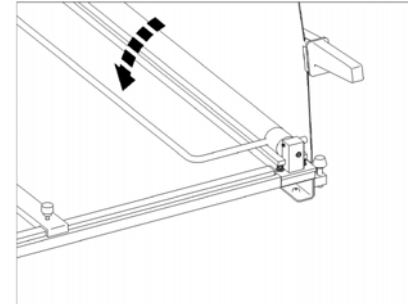

BLADE ADJUSTMENT

The Blade is pre-set and should stay in the open position without failing. Should adjustment be necessary, the large chrome lock nut may be tightened until the blade stays up. Do not over tighten.

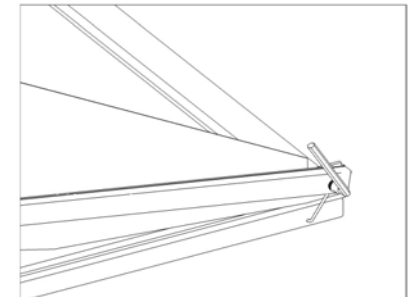

USING THE CUTTER

Proper operation of you Cutter is important to fine cuts and long life. This cutter is capable of cutting and trimming a variety of materials from a few thousandths of an inch thick to over 1/4 of an inch. The type and thickness of the material your Dahle will cut is determined by the density or toughness of the material itself. We recommend to angle the blade slightly in the direction of the cutting edge in order to achieve a clean cut with even the finest paper. With proper operation, your Cutter will produce clean, straight cuts.

ACCURACY

The Scales on your Cutter are carefully adjusted to be a true 90 degrees to the blade. Careful positioning of work and use of the hold-down will ensure accurate cuts.