



75000 Series C

# Agilent E8408A C-Size VXI Mainframe

## User and Service Manual

### Where to Find it - Online and Printed Information

This manual is distributed as follows:

Agilent Universal Instrument Drivers CD ROM ( included with the mainframe)  
World Wide Web at <http://www.agilent.com/find/products>

For related information:

System installation (hardware/software) ..... VXIbus Configuration Guide\*

\* *Supplied with Agilent Command Module, Embedded Controllers, and VXLink*



**Agilent Technologies**



Manual Part Number: E8408-90001  
Printed in Malaysia E0912

NOTICE: In August 2014, Agilent Technologies' former Test and Measurement business became Keysight Technologies. This document is provided as a courtesy but is no longer kept current and thus will contain historical references to Agilent. For more information, go to **[www.keysight.com](http://www.keysight.com)**.





# Contents

## E8408A C-Size VXI Mainframe User and Service Manual

---

<b>Front Matter</b> .....	<b>5</b>
Agilent Technologies Warranty Statement.....	5
U.S. Government Restricted Rights.....	5
Trademark Information.....	5
Documentation History.....	6
Safety Symbols.....	6
Warnings.....	6
Declaration Of Conformity.....	7
<b>Chapter 1 - Getting Started</b> .....	<b>9</b>
Chapter Overview .....	9
Product Overview.....	9
Initial Mainframe Setup .....	11
AC Power Requirements .....	11
Positioning the Mainframe for Adequate Cooling .....	11
Connecting Permanent Earth Ground .....	12
Installing VXI Instruments .....	13
Slot 0 Functions .....	13
Installation Guidelines .....	13
Installing VXI Instruments Using VIC .....	14
Installing C-Size Instruments .....	14
Installing A- and B-Size Instruments .....	14
Front Panel Features .....	16
<b>Chapter 2 - Installing Mainframe Options</b> .....	<b>17</b>
Chapter Overview .....	17
Converting to Portable Configuration.....	17
Parts List .....	17
Installation Procedure .....	18
Rack Mounting Using Rack Slide Kit.....	20
Parts List .....	20
Installation Procedure .....	20
Rack Mounting Using Support Rail Kit.....	31
Parts List .....	31
Installation Procedure .....	31
Installing Intermodule Chassis Shields .....	40
Parts List .....	40
Installation Procedure .....	40

Installing Backplane Connector Shields.....	41
Parts List .....	41
Installation Procedure .....	42
Installing the Airflow Restrictor Kit.....	43
<b>Chapter 3 - Servicing the Mainframe .....</b>	<b>45</b>
Chapter Overview .....	45
Replaceable Parts List.....	45
Problem Isolation .....	46
Replacing Mainframe Components.....	46
Removing Mainframe Accessory Items .....	47
Removing the Mainframe Cover .....	48
Replacing the Power Supply Assembly .....	49
Replacing the Monitor Board .....	50
Replacing the Fan Assembly .....	51
Replacing the Front Panel Tapped Strip .....	52
Replacement Power Cords .....	53
Cleaning Instructions .....	53
<b>Appendix A - E8408A Product Specifications .....</b>	<b>55</b>
Product Description.....	55
Product Dimensions .....	55
Options and Accessories .....	56
General VXI Specifications .....	57
Monitor Specifications .....	57
Backplane Specifications .....	57
Power Specifications.....	58
Total Usable Power .....	58
Peak and Dynamic Current .....	58
Output Voltage .....	59
Power Input .....	59
Cooling Specifications.....	60
Cooling Table .....	60
Cooling Chart .....	60
Safety/Environmental Specifications.....	61
Environmental Specifications .....	61
Electromagnetic Compliance/Safety Specifications .....	62
Power Supply Protection .....	62
Repair .....	63
<b>Index .....</b>	<b>65</b>

---

## AGILENT TECHNOLOGIES WARRANTY STATEMENT

**AGILENT PRODUCT:** E8408A C-Size VXI Mainframe

**DURATION OF WARRANTY:** 3 years

1. Agilent Technologies warrants Agilent hardware, accessories and supplies against defects in materials and workmanship for the period specified above. If Agilent receives notice of such defects during the warranty period, Agilent will, at its option, either repair or replace products which prove to be defective. Replacement products may be either new or like-new.
2. Agilent warrants that Agilent software will not fail to execute its programming instructions, for the period specified above, due to defects in material and workmanship when properly installed and used. If Agilent receives notice of such defects during the warranty period, Agilent will replace software media which does not execute its programming instructions due to such defects.
3. Agilent does not warrant that the operation of Agilent products will be interrupted or error free. If Agilent is unable, within a reasonable time, to repair or replace any product to a condition as warranted, customer will be entitled to a refund of the purchase price upon prompt return of the product.
4. Agilent products may contain remanufactured parts equivalent to new in performance or may have been subject to incidental use.
5. The warranty period begins on the date of delivery or on the date of installation if installed by Agilent. If customer schedules or delays Agilent installation more than 30 days after delivery, warranty begins on the 31st day from delivery.
6. Warranty does not apply to defects resulting from (a) improper or inadequate maintenance or calibration, (b) software, interfacing, parts or supplies not supplied by Agilent, (c) unauthorized modification or misuse, (d) operation outside of the published environmental specifications for the product, or (e) improper site preparation or maintenance.
7. TO THE EXTENT ALLOWED BY LOCAL LAW, THE ABOVE WARRANTIES ARE EXCLUSIVE AND NO OTHER WARRANTY OR CONDITION, WHETHER WRITTEN OR ORAL, IS EXPRESSED OR IMPLIED AND AGILENT SPECIFICALLY DISCLAIMS ANY IMPLIED WARRANTY OR CONDITIONS OF MERCHANTABILITY, SATISFACTORY QUALITY, AND FITNESS FOR A PARTICULAR PURPOSE.
8. Agilent will be liable for damage to tangible property per incident up to the greater of \$300,000 or the actual amount paid for the product that is the subject of the claim, and for damages for bodily injury or death, to the extent that all such damages are determined by a court of competent jurisdiction to have been directly caused by a defective Agilent product.
9. TO THE EXTENT ALLOWED BY LOCAL LAW, THE REMEDIES IN THIS WARRANTY STATEMENT ARE CUSTOMER'S SOLE AND EXCLUSIVE REMEDIES. EXCEPT AS INDICATED ABOVE, IN NO EVENT WILL AGILENT OR ITS SUPPLIERS BE LIABLE FOR LOSS OF DATA OR FOR DIRECT, SPECIAL, INCIDENTAL, CONSEQUENTIAL (INCLUDING LOST PROFIT OR DATA), OR OTHER DAMAGE, WHETHER BASED IN CONTRACT, TORT, OR OTHERWISE.

FOR CONSUMER TRANSACTIONS IN AUSTRALIA AND NEW ZEALAND: THE WARRANTY TERMS CONTAINED IN THIS STATEMENT, EXCEPT TO THE EXTENT LAWFULLY PERMITTED, DO NOT EXCLUDE, RESTRICT OR MODIFY AND ARE IN ADDITION TO THE MANDATORY STATUTORY RIGHTS APPLICABLE TO THE SALE OF THIS PRODUCT TO YOU.

---

### U.S. Government Restricted Rights

The Software and Documentation have been developed entirely at private expense. They are delivered and licensed as "commercial computer software" as defined in DFARS 252.227- 7013 (Oct 1988), DFARS 252.211-7015 (May 1991) or DFARS 252.227-7014 (Jun 1995), as a "commercial item" as defined in FAR 2.101(a), or as "Restricted computer software" as defined in FAR 52.227-19 (Jun 1987)(or any equivalent agency regulation or contract clause), whichever is applicable. You have only those rights provided for such Software and Documentation by the applicable FAR or DFARS clause or the Agilent standard software agreement for the product involved.

---

### Trademark Information

Microsoft ®, Windows ®, and Windows® NT are registered trademarks of the Microsoft Corporation.  
All other brand and product names are trademarks or registered trademarks of their respective companies



E8408A C-Size VXI Mainframe User and Service Manual  
Edition 2  
Copyright © 1999, 2000, 2015 Agilent Technologies, Inc. All rights reserved.

---

## Documentation History

All Editions and Updates of this manual and their creation date are listed below. The first Edition of the manual is Edition 1. The Edition number increments by 1 whenever the manual is revised. Updates, which are issued between Editions, contain replacement pages to correct or add additional information to the current Edition of the manual. Whenever a new Edition is created, it will contain all of the Update information for the previous Edition. Each new Edition or Update also includes a revised copy of this documentation history page.

Edition 1 ..... March, 1999  
Edition 2 ..... February, 2000  
Edition 2 Rev. 1 ..... February, 2012  
Edition 2 Rev. 2 ..... August, 2015

---

## Safety Symbols



Instruction manual symbol affixed to product. Indicates that the user must refer to the manual for specific **WARNING** or **CAUTION** information to avoid personal injury or damage to the product.



Indicates the field wiring terminal that must be connected to earth ground before operating the equipment — protects against electrical shock in case of fault.

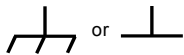

Frame or chassis ground terminal—typically connects to the equipment's metal frame.



Alternating current (AC)



Direct current (DC).

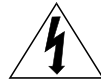

Indicates hazardous voltages.

**WARNING**

Calls attention to a procedure, practice, or condition that could cause bodily injury or death.

**CAUTION**

Calls attention to a procedure, practice, or condition that could possibly cause damage to equipment or permanent loss of data.

---

## WARNINGS

The following general safety precautions must be observed during all phases of operation, service, and repair of this product. Failure to comply with these precautions or with specific warnings elsewhere in this manual violates safety standards of design, manufacture, and intended use of the product. Agilent Technologies assumes no liability for the customer's failure to comply with these requirements.

**Ground the equipment:** For Safety Class 1 equipment (equipment having a protective earth terminal), an uninterruptible safety earth ground must be provided from the mains power source to the product input wiring terminals or supplied power cable.

**DO NOT operate the product in an explosive atmosphere or in the presence of flammable gases or fumes.**

For continued protection against fire, replace the line fuse(s) only with fuse(s) of the same voltage and current rating and type. **DO NOT** use repaired fuses or short-circuited fuse holders.

**Keep away from live circuits:** Operating personnel must not remove equipment covers or shields. Procedures involving the removal of covers or shields are for use by service-trained personnel only. Under certain conditions, dangerous voltages may exist even with the equipment switched off. To avoid dangerous electrical shock, **DO NOT** perform procedures involving cover or shield removal unless you are qualified to do so.

**DO NOT operate damaged equipment:** Whenever it is possible that the safety protection features built into this product have been impaired, either through physical damage, excessive moisture, or any other reason, **REMOVE POWER** and do not use the product until safe operation can be verified by service-trained personnel. If necessary, return the product to Agilent for service and repair to ensure that safety features are maintained.

**DO NOT service or adjust alone:** Do not attempt internal service or adjustment unless another person, capable of rendering first aid and resuscitation, is present.

**DO NOT substitute parts or modify equipment:** Because of the danger of introducing additional hazards, do not install substitute parts or perform any unauthorized modification to the product. Return the product to Agilent for service and repair to ensure that safety features are maintained.

---

## Declaration of Conformity

Declarations of Conformity for this product and for other Agilent products may be downloaded from the Internet. There are two methods to obtain the Declaration of Conformity:

- Go to <http://regulations.about.keysight.com/DoC/search.htm> . You can then search by product number to find the latest Declaration of Conformity.
- Alternately, you can go to the product web page ([www.keysight.com/find/E8408A](http://www.keysight.com/find/E8408A)), click on the Document Library tab then scroll down until you find the Declaration of Conformity link.



**Notes:**

---

## Chapter Overview

Chapter contents are:

• Product Overview . . . . .	9
• Initial Mainframe Setup . . . . .	11
• Installing VXI Instruments . . . . .	13
• Front Panel Features . . . . .	16

## Product Overview

The E8408A VXI mainframe is designed in full compliance with VXIbus specification revision 1.4 and VMEbus system specification revision C.1. The mainframe has three configurations: Standard, Portable, and Rack Mount.

- The **Standard Configuration** consists of the 4-slot C-size mainframe with front panel monitor, protective bumpers and a carrying handle. Optional filler panels and shields can be added to the Standard Configuration.

The Standard Configuration also includes **Option 001** that provides more current from the -5.2V source. This option allows the mainframe to be used for VXI modules that require more current, such as the E1430, E1437, E1438, and E1439 digitizers.

- The **Portable Configuration** consists of the Standard Configuration plus a carrying strap and an accessory pouch to carry a laptop PC, cables, etc. when transporting the mainframe.
- The **Rack Mount Configuration** consists of the Standard Configuration with the protective bumpers and carrying handle removed. For this configuration, the mainframe can be rack mounted using the Rack Mount/Cable Route Adapter Kit with either the Rack Slide Kit or the Support Rail Kit.

Figure 1-1 shows the options and accessories available for the E8408A mainframe. See *Appendix A - E8408A Product Specifications* for description and part numbers for mainframe and accessories options.

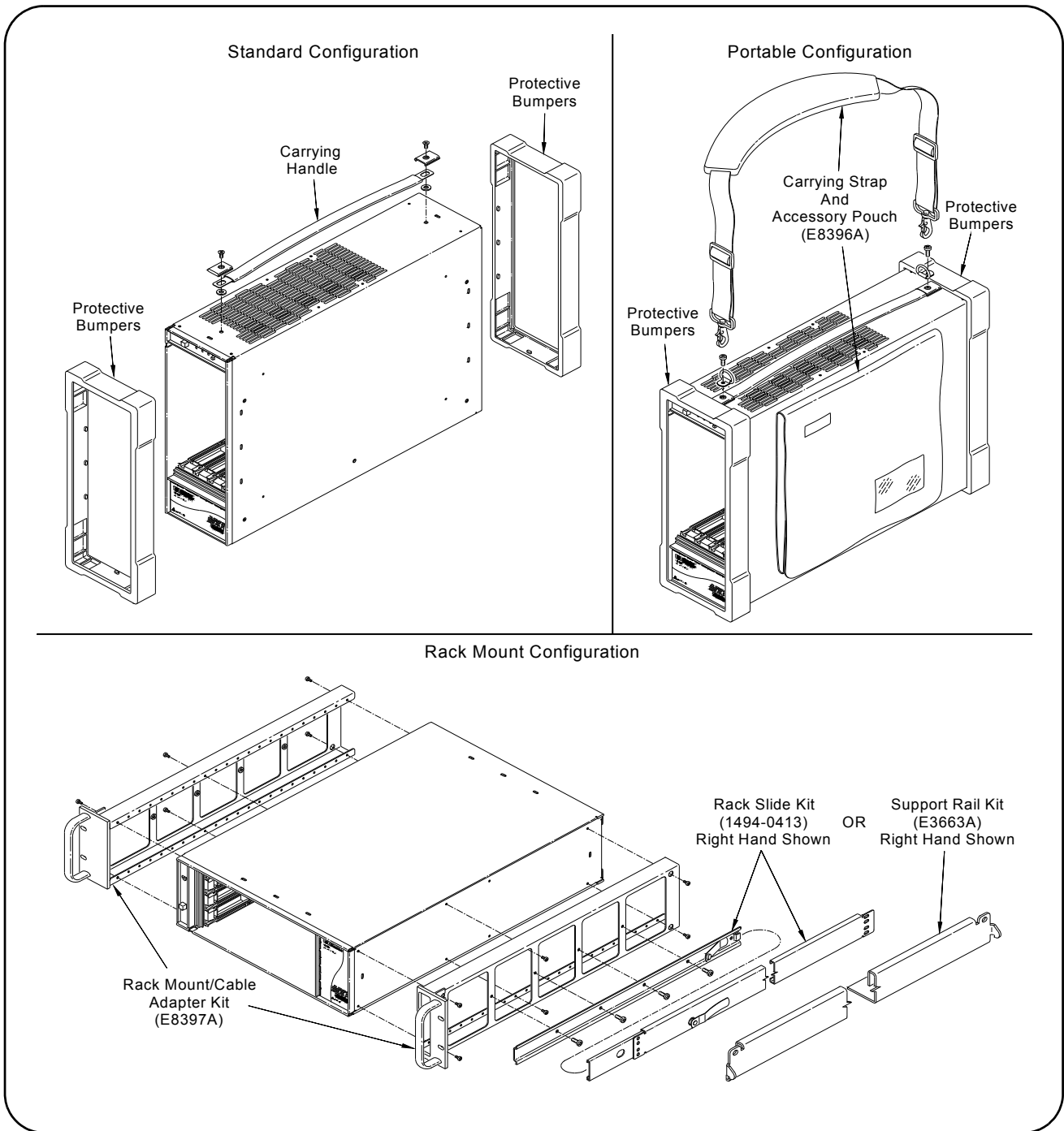

Figure 1-1. E8408A Mainframe Configurations/Options

# Initial Mainframe Setup

The E8408A mainframe is shipped from the factory ready to use. This section describes procedures for initial mainframe setup, including:

- AC Power Requirements
- Positioning the Mainframe for Adequate Cooling
- Connecting Permanent Earth Ground

---

**Note** This chapter shows initial setup procedures for the Standard Configuration.  
See *Chapter 2 - Installing Mainframe Options* for information on rack mounting the mainframe and installing mainframe options.

---

## AC Power Requirements

The E8408A mainframe can be operated at line voltages of 90 - 140 Vac (@ 47 Hz to 440 Hz) or 90 - 264 Vac (@47 - 66 Hz). The mainframe ships with a power cord and with a fuse installed in the power supply. The fuse is suitable for all line voltages, but is not accessible. *Appendix A - E8408A Product Specifications* contains input power specifications.

---

**WARNING** **The power cord is the only way to disconnect the mainframe from AC power. Therefore, the power cord must be accessible to the operator at all times. When the E8408A mainframe is mounted in a system cabinet, the power cord need not be accessible since the cabinet must have its own disconnect device. Some fault conditions require removal of AC power for recovery to occur. See *Chapter 3 - Servicing the Mainframe*.**

---

## Positioning the Mainframe for Adequate Cooling

A cooling fan provides air for module and power supply cooling. The fan operates in Variable Speed or Full Speed mode as controlled by the front panel Fan Speed switch. Full Speed mode is recommended for maximum cooling when acoustic noise is not a factor.

Variable Speed mode allows quietest operation while providing sufficient power supply and module cooling. In Variable Speed mode, the fan speed is controlled automatically as a function of temperature rise in the mainframe and the ambient temperature.

Airflow enters the E8408A mainframe rear panel, flows through the power supply, fan and modules and exhausts out the left side (as viewed from the front in horizontal orientation). This allows mainframes to be stacked or rack-mounted directly on top of one another.

When placing the mainframe on a work bench or if the mainframe is rack mounted, provide at least a one-inch clearance at the back and sides to allow proper air flow. (Air filters are not necessary on E8408A mainframes.)

## Connecting Permanent Earth Ground

The mainframe can be connected to a permanent earth ground. This connection is made on the back of the mainframe (see Figure 1-2).

---

**WARNING** For protection from electrical shock when operating at frequencies greater than 66 Hz, connect the chassis ground terminal to permanent earth ground.

---

1. Connect a 16 AWG (1.3 mm or larger) wire to the PEM nut shown in Figure 1-2. The wire must be green with a yellow stripe, or bare (no insulation). Use a M4 x 10 screw, grounding lug, and toothed washers (or toothed lug) as shown in Figure 1-2.
2. Attach the other end of the wire to a permanent earth ground using toothed washers or a toothed lug.

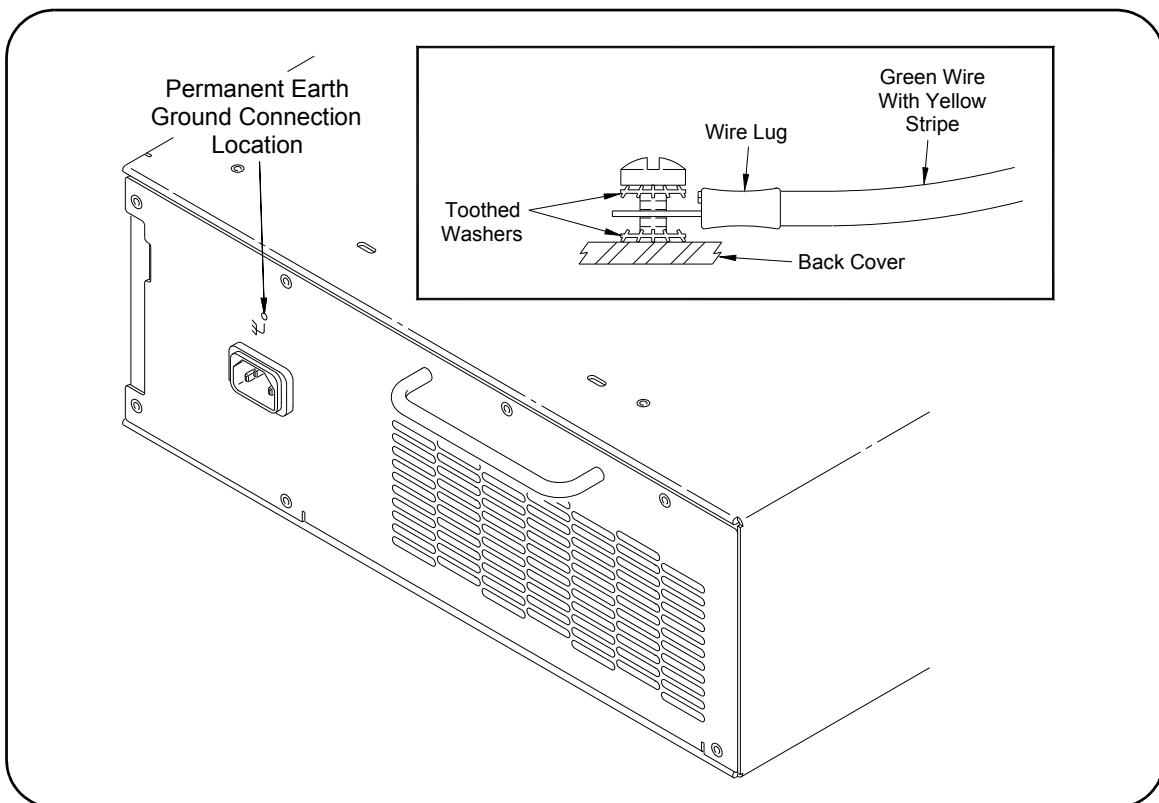

Figure 1-2. Connecting the E8408A Mainframe to a Permanent Earth Ground

# Installing VXI Instruments

This section shows how to install A-, B-, and C-Size VXI instruments (modules) in an E8408A mainframe, including:

- Slot 0 Functions
- Installation Guidelines
- Installing C-Size Instruments
- Installing A- and B-Size Instruments

## Slot 0 Functions

The E8408A mainframe has 4 slots labeled 0 through 3. Any VXI instrument can be installed in slots 1 through 3. However, slot 0 is reserved for devices capable of providing the system's slot 0 functionality, such as the E1406A Command Module (GPIB) or E8491A (IEEE 1394). This functionality includes:

- locating instruments installed in the mainframe
- managing (arbitrating) data flow across the backplane
- providing the system clock (SYSCLK - 16 MHz)

## Installation Guidelines

1. Multiple instruments that combine to create a virtual instrument (e.g., a scanning multimeter), and instruments which access the backplane local bus should be installed in adjacent slots.
2. To prevent damage to VXI instruments, do not install instruments unless the **Power On/Standby** switch is in Standby position.
3. Insert the instrument into the mainframe by aligning the instrument with the card guides inside the mainframe. Slowly push the instrument into the slot until it seats in the backplane connectors. The front panel of the instrument should be even with the front edges of the mainframe.

When installing or removing an instrument in Slot 0, you will need to move the front panel protective bumper aside. Restore the bumper to its original position after the instrument is installed or removed.

4. Tighten the retaining screws on the top and bottom of the module.

---

### WARNING

**All instruments within the VXI mainframe are grounded through the mainframe chassis. During installation, tighten the instrument's retaining screws to secure the instrument to the mainframe and to make the ground connection.**

---

### Note

*The E8408A is shipped with 1-slot (E8408-44305) and/or 3-slot (E8400-44306) plastic filler panels that do not provide EMC protection.*

*To comply with EMC requirements, order 1-slot metal filler panels (E8400-60202) to cover empty mainframe slots.*

---

## Installing VXI Instruments Using VIC

If you use an E1406A Command Module or an E8491A PC Link to VXI Interconnect in Slot 0 of the mainframe, you can use the *Agilent Technologies VXI Installation Consultant (VIC)* to assist you in installing VXI instruments. To use VIC, follow these steps. For actual installation of instruments into the mainframe, see "Installing C-Size Instruments" or "Installing "A- or B-Size Instruments".

1. Insert the *Agilent Technologies Universal Instrument Drivers CD* (received with your Slot 0 card) into your CD-ROM drive and wait a few seconds for the setup instructions to appear.
2. If the setup screen does not appear in a few seconds, click *Start|Run* and type *<drive>:setup.exe* in the Run box, where *drive* is your CD-ROM drive.
3. When the main menu appears, click *Launch Installer or View Manuals*. Click *Next* on the next screen and *Yes* on the third screen to go to the **Choose Type of Installation** screen.
4. Click the *RUN VIC...* icon and then click *Next* to start VIC. Follow the onscreen instructions to install VXI instruments in the mainframe.

## Installing C-Size Instruments

Figure 1-3 shows typical installation of C-Size instruments. Power requirements for the following C-Size instruments are NOT supported in the Standard version of the E8408A and should NOT be installed in an E8408A mainframe.

---

**Note** *The E1430A and E1437A digitizers can be installed if you have Option 001.*

---

- E1426A 500 MHz, 4-Channel VXI Oscilloscope
- E1428A 1 GSa/s VXI Oscilloscope
- E1429A/B 20 MS/s A/Ds
- E1430A 10 MS/s, 23bit, A/D with Filter and Memory
- E1437A 20 MSa/s Digitizer with DSP
- E1445A Arbitrary Function Generator
- E1450A Timing Module
- E1451A/E1452A I/O Modules
- E1476A/B SONET Modules
- E1740A Time Interval Analyzer

## Installing A- and B-Size Instruments

Figure 1-4 shows typical installation of A- and B-size instruments.

- **E1403B A/B-size Module Carrier** extends the P1 connector on the VXIbus backplane and mounts the (A/B-size) modules flush with C-size modules. This carrier is recommended for Agilent B-size, slave-only devices which have the P1 connector.
- **E1407A A/B Module Carrier** extends the P1 and P2 connectors on the VXIbus backplane. This carrier is recommended for B-Size, slave-only devices which have the P1/P2 connectors.

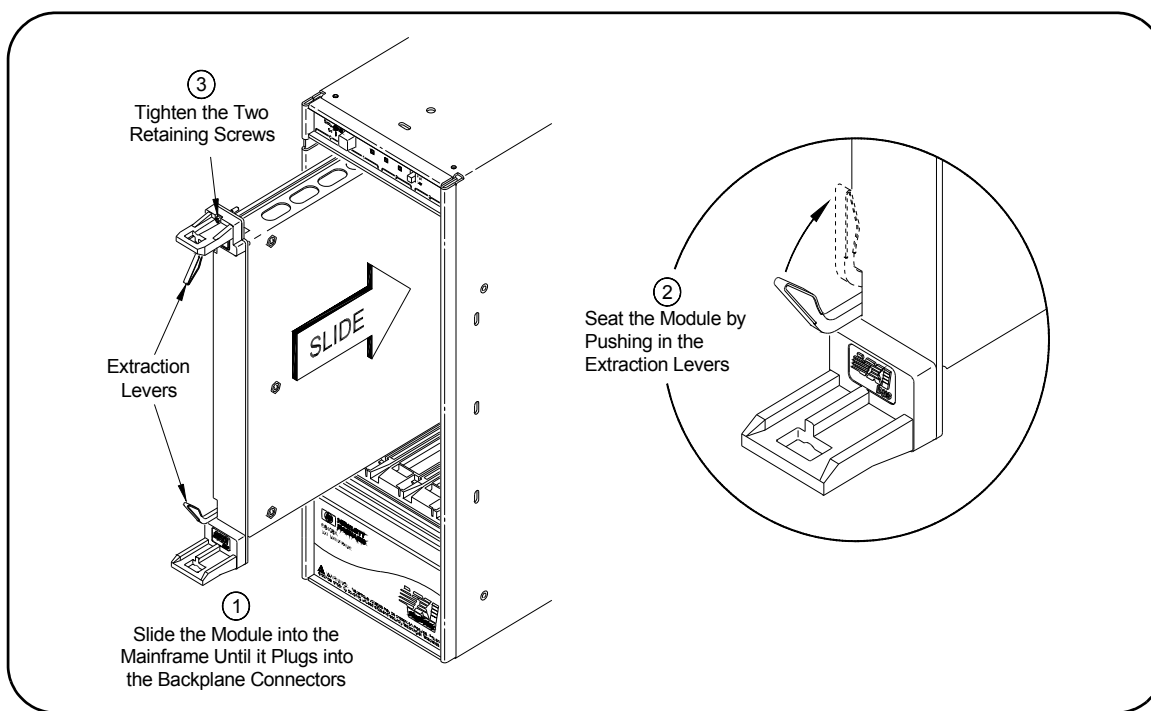

Figure 1-3. Installing C-Size Instruments in the E8408A Mainframe



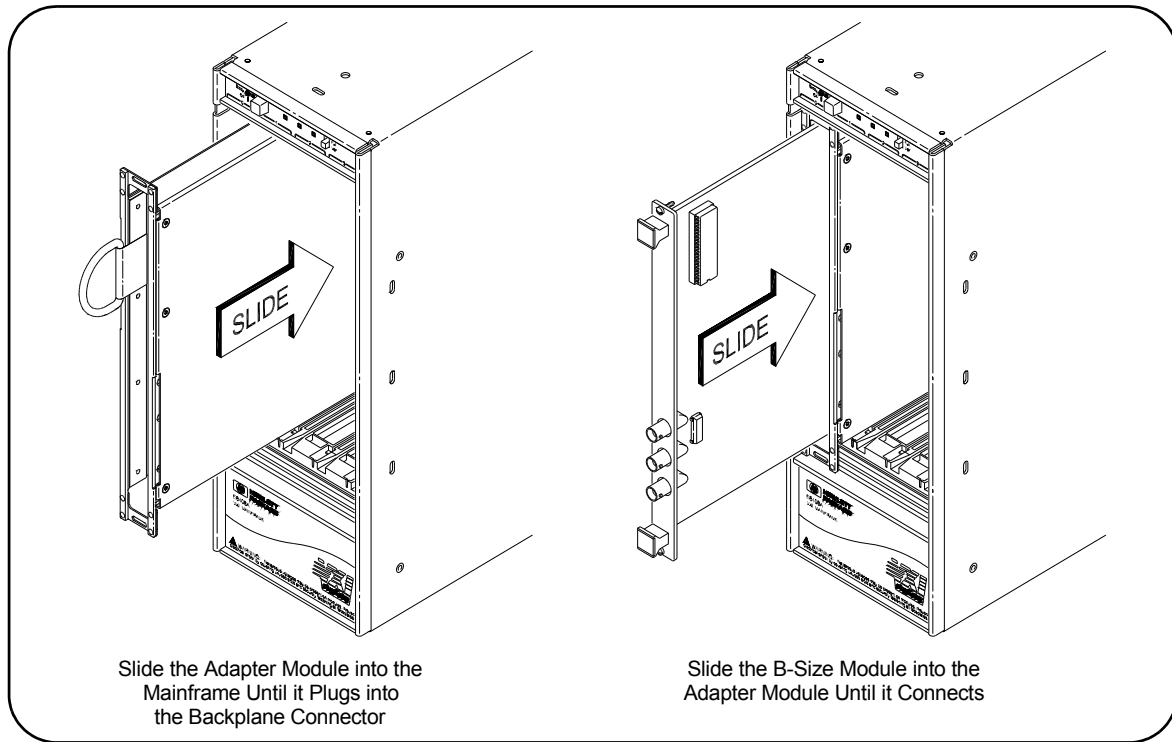
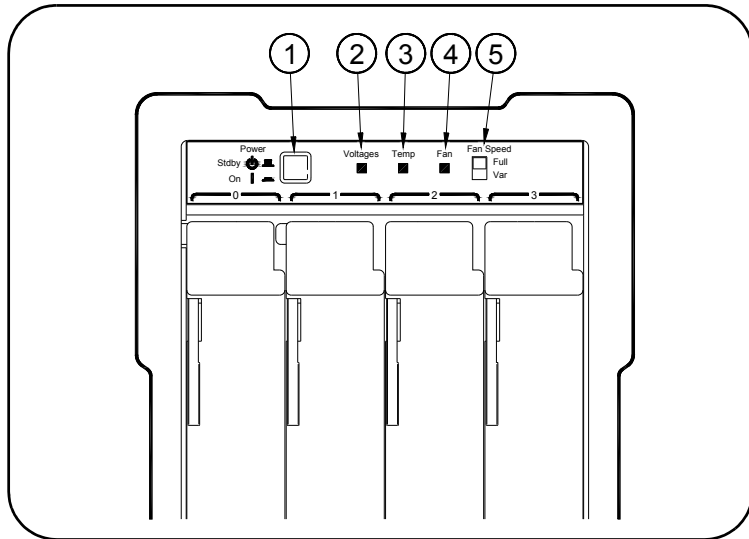

Figure 1-4. Installing A- and B-Size Instruments in the E8408A Mainframe

## Front Panel Features

Figure 1-5 shows the E8408A Front Panel features, and the table describes the features. When the mainframe is connected to an AC supply and the **Power** Switch is pressed ON, the **Voltages**, **Temp**, and **Fan** lights flash Amber for about one second, and then turn Green. These lights should remain Green. A flashing Amber light indicates an error condition. In this

case, see *Chapter 3 - Servicing the Mainframe*.



**Figure 1-5. E8408A Mainframe Front Panel Features**

No.	Indicator/Switch	Description																
1	Power Switch	<b>Stdy</b> - AC power is applied to the mainframe, but not to installed VXI instruments. <b>On</b> - AC power applied to the mainframe, and DC power to installed VXI instruments.																
2	Voltages Indicator	<b>Green</b> - all voltages on the VXI backplane are present. (Does not necessarily indicate voltages are within VXI specifications.) <b>Flashing Amber</b> - one or more voltages is not present or is incorrect. The backplane voltages and allowed variations are listed below:  <table border="1" style="margin-left: 40px;"> <thead> <tr> <th>Voltage</th> <th>Allowed Variation</th> </tr> </thead> <tbody> <tr> <td>+5V</td> <td>+4.875V to +5.125V</td> </tr> <tr> <td>+12V</td> <td>+11.64V to +12.6V</td> </tr> <tr> <td>-12V</td> <td>-12.6V to -11.64V</td> </tr> <tr> <td>+24V</td> <td>+23.28V to +25.2V</td> </tr> <tr> <td>-24V</td> <td>-25.2V to -23.28V</td> </tr> <tr> <td>-5.2V</td> <td>-5.46V to -5.044V</td> </tr> <tr> <td>-2V</td> <td>-2.1V to -1.9V</td> </tr> </tbody> </table>	Voltage	Allowed Variation	+5V	+4.875V to +5.125V	+12V	+11.64V to +12.6V	-12V	-12.6V to -11.64V	+24V	+23.28V to +25.2V	-24V	-25.2V to -23.28V	-5.2V	-5.46V to -5.044V	-2V	-2.1V to -1.9V
Voltage	Allowed Variation																	
+5V	+4.875V to +5.125V																	
+12V	+11.64V to +12.6V																	
-12V	-12.6V to -11.64V																	
+24V	+23.28V to +25.2V																	
-24V	-25.2V to -23.28V																	
-5.2V	-5.46V to -5.044V																	
-2V	-2.1V to -1.9V																	
3	Temp Indicator	<b>Green</b> - the power supply temperature is acceptable. <b>Flashing Amber</b> - the power supply is approaching thermal shutdown.																
4	Fan Indicator	<b>Green</b> - mainframe cooling fan is operating properly. <b>Flashing Amber</b> - mainframe cooling fan is not operating.																
5	Fan Speed Switch	<b>Full</b> - the mainframe cooling fan is operating at full speed. <b>Var(iable)</b> - the mainframe cooling fan is providing adequate cooling (default setting).																

---

**WARNING** Hazardous voltages may be present on modules. Prevent electrical shock by covering all unused slots and securely fastening all faceplates.

---

**AVERTISSEMENT**

---

**Des tensions dangereuses peuvent être présentes sur les modules. Éviter les chocs électriques en couvrant tous les emplacements inutilisés et fixer solidement tous les plastrons/caches.**

---

# Chapter 2

## Installing Mainframe Options

---

### Chapter Overview

This chapter contains procedures to install hardware options available with the E8408A mainframe, including:

- Converting to Portable Configuration . . . . . 17
- Rack Mounting Using Rack Slide Kit . . . . . 20
- Rack Mounting Using Support Rail Kit . . . . . 31
- Installing Intermodule Chassis Shields . . . . . 40
- Installing Backplane Connector Shields . . . . . 41
- Installing the Airflow Restrictor Kit . . . . . 43

---

**NOTE** *Mainframe illustrations in this chapter may show empty mainframes. However, you may receive integrated (pre-configured) VXI systems with VXI instruments (modules) already installed in the mainframe.*

*In general, you will NOT need to remove the VXI instruments to perform installation procedures in this chapter. However, to install shields you must first remove any installed instruments. To do this, reverse the procedure in Installing VXI Instruments in Chapter 1 - Getting Started to remove the instruments.*

---

### Converting to Portable Configuration

The E8408A mainframe can be converted to the Portable Configuration by adding a carrying strap and an accessory pouch (E8396A) to the Standard Configuration (see Figure 2-1). As desired, you can attach a Laptop PC to the Laptop PC Platform shipped with the E8396A.

#### Parts List

Table 2-1 shows the parts required to convert the E8408A mainframe Standard Configuration to the Portable Configuration.

**Table 2-1. Portable Configuration Parts List**

Description	Part Number
Portable Configuration, Includes:	E8396A
- Carrying Strap w/attachment hardware	E8408-51201
- Accessory Pouch w/attachment hardware	E8408-54401
- Laptop PC Platform	E8408-54101

## Installation Procedure

There are two main steps to convert to Portable Configuration for the E8408A mainframe:

- Attach Carrying Strap and Accessory Pouch
- Attach Laptop PC (Optional)

### Attaching Carrying Strap and Accessory Pouch

- 1 Remove the two M5 x 10 flat head screws from the carrying handle.
- 2 Attach Carrying Strap D-rings to the Carrying Handle using the two D-rings and the two M5 X 16 pan head screws. Be sure to replace the washers underneath the handle retainers.
- 3 Attach the Accessory Pouch to the mainframe using four screws. Then, clip the carrying strap to the D-rings.

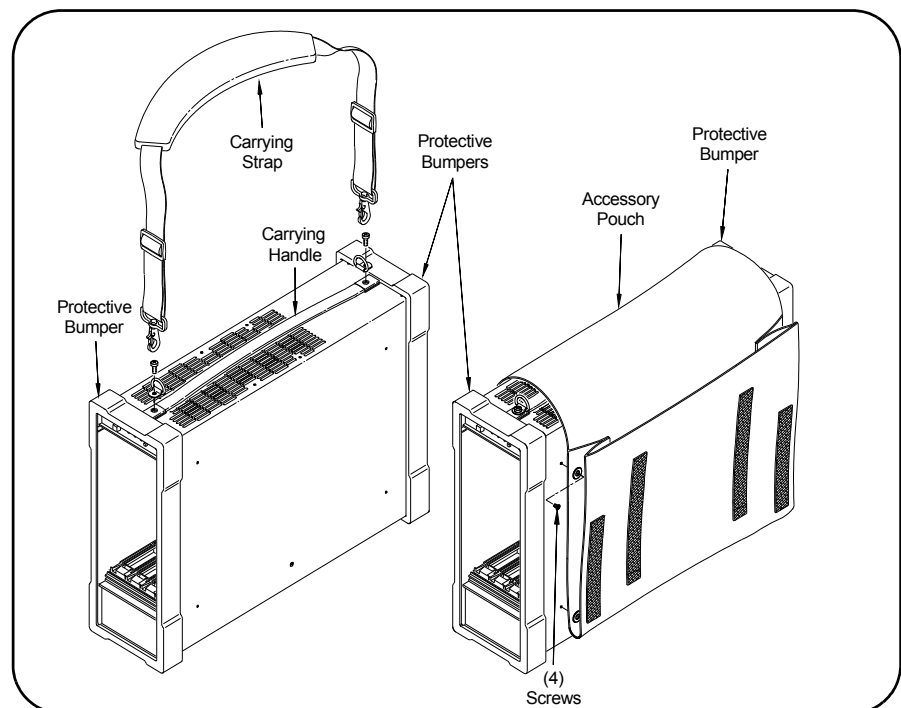

**Figure 2-1. Attaching Carrying Strap and Accessory Pouch**

### Attaching Laptop PC (Optional)

A Laptop PC Platform is enclosed in the Accessory Pouch that you can use to hold your Laptop PC secure when using the PC in an application with the mainframe in horizontal orientation, such as on a car seat or lab benchtop.

The Laptop PC can be attached to the outside of the Accessory Pouch using the four hook and loop squares on the Laptop PC Platform. To attach the Laptop PC to the Laptop PC Platform:

- 1 Remove the Laptop PC Platform from the Accessory Pouch.
- 2 Be sure the mainframe is in horizontal orientation. Then, attach the Laptop PC Platform to the outside of the Accessory Pouch, using the two long hook and loop strips on the platform.

- 3 Follow the steps in Figure 2-2 to attach the PC to the Laptop PC Platform.

---

**NOTE** *Once the hook and loop squares are attached to your Laptop PC, they will not interfere with the use of the PC for other applications. After initial installation, you can easily remove the PC and reattach it as needed.*

---

- 4 As desired, connect an interface cable from the PC to the Slot 0 card in the mainframe.

---

**CAUTION** **Use Care When Mainframe is in Vertical Orientation.** Do not attempt to move or use an attached Laptop PC with the mainframe in vertical orientation as the PC can easily fall off or be detached when the mainframe is in vertical orientation.

---

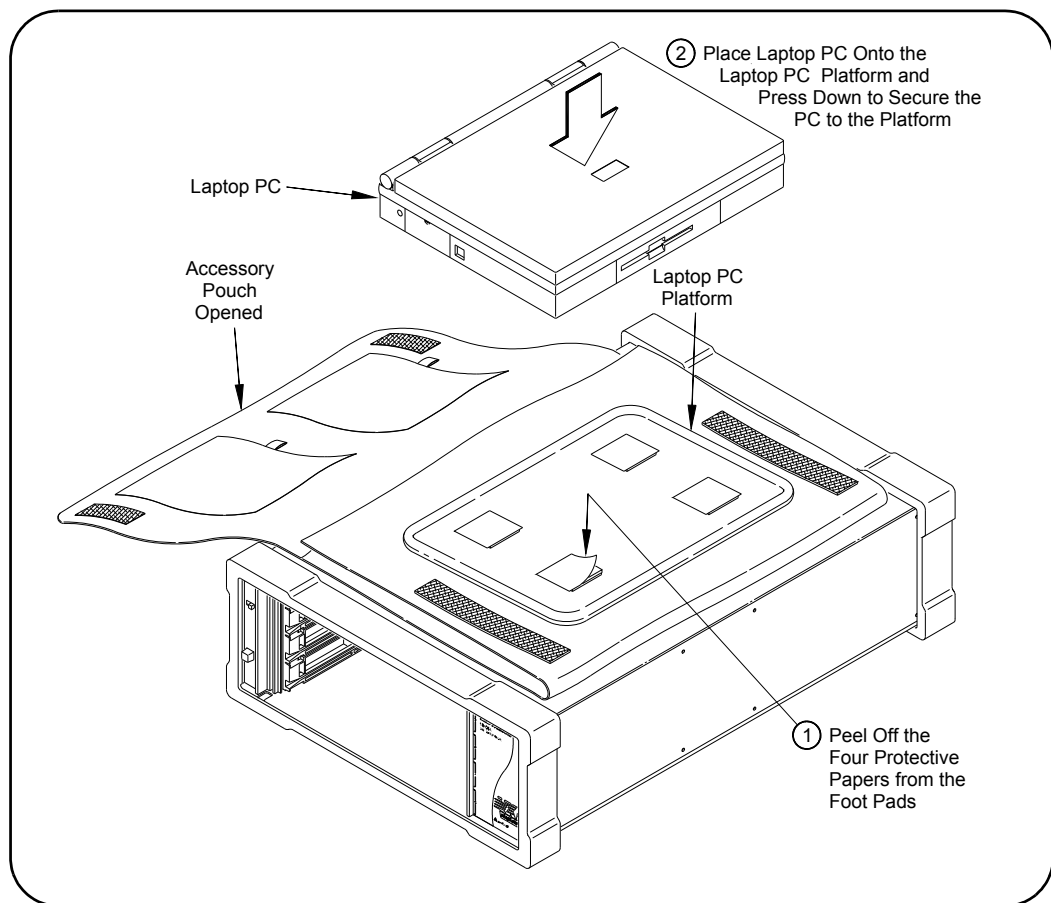

**Figure 2-2. Attaching Laptop PC to Accessory Pouch**

# Rack Mounting Using Rack Slide Kit

This section contains instructions to mount the E8408A mainframe in a standard EIA cabinet using the Rack Mount/Cable Route Adapter Kit (E8397A) and the Rack Slide Kit (p/n 1494-0413). The rack slide kit allows you to extend the mainframe from the cabinet for easier access to installed instruments.

**Parts List** Table 2-2 shows the parts for the Standard Rack Mount/Cable Routing Kit and for the Rack Slide Kit.

**Table 2-2. Rack Mount Kit and Rack Slide Kit Parts Lists**

Quantity	Description	Part Number
<b>Rack Mount/Cable Route Adapter Kit (E8397A)</b>		
1	Rack Mount Adapter (right)	E8408-61200
1	Rack Mount Adapter (left)	E8408-61201
2	Handle (for Rack Mount Adapters)	RAF p/n 8344-1032-A34
4	10-32 X 0.375" Flat Head Screw (Handle Screws)	2680-0100
12	M3 X 0.5 Pan Head Screw (Adapter-to Mainframe Screws)	0515-0372
4	Adapter Dress Screw	0570-1577
4	Self-Retained Nut (for Rack Mount Adapters)	0590-0804
1	Front Panel Label Set (Rack-Mount Orientation)	E8408-84305
<b>Rack Slide Kit (1494-0413)*</b>		
1 pair	Rack Slides	General Devices p/n CC1502-99-0016
12	10-32 X .375" Pan Head Screw	0515-0904
4	10-32 X .50" Flat Head Screw	0515-0956
8	10-32 Self-Retained Nut	0590-0804

\* For non-Agilent cabinets, must add 1494-0061 End Brackets

## Installation Procedure

There are three main steps to rack mount the E8408A mainframe using the Rack Mount/Cable Route Adapter Kit (E8397A) and the Rack Slide Kit (1494-0413):

- Configure the Mainframe
- Set up Rack Cabinet
- Install the Mainframe

## Configure the Mainframe Remove Mainframe Items (as applicable) (Figure 2-3)

- 1 Remove the carrying handle/carrying strap.
- 2 Remove the two protective bumpers.
- 3 Remove the Accessory Pouch.

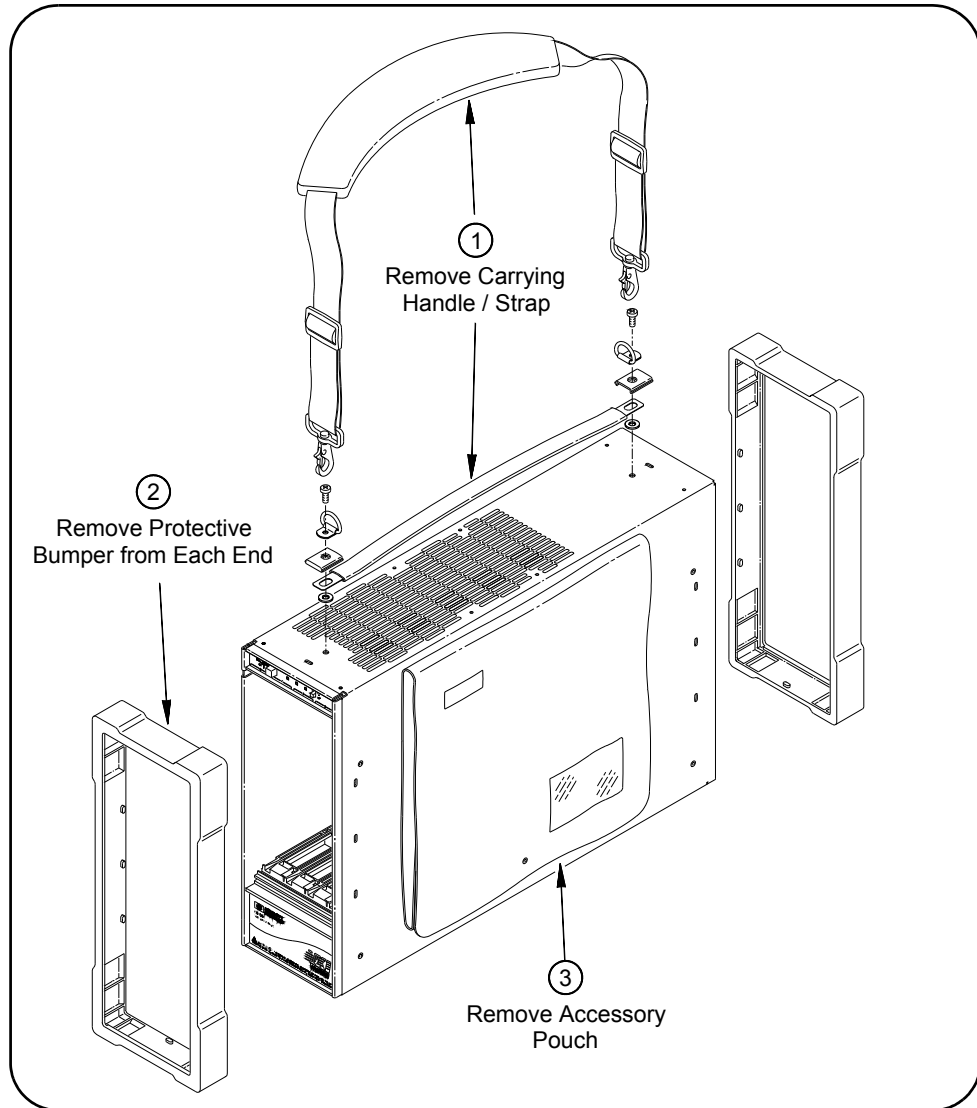

Figure 2-3. Removing Mainframe Items



### Install Rack Mount Labels (Figure 2-4)

- 1 Lay mainframe on its left side.
- 2 Open the Rack Mount/Cable Route Adapter Kit (E8397A).
- 3 Peel the protective backing from the two rack-mount front panel labels (in the E8397A kit) and carefully place them over the existing labels. Press to adhere.

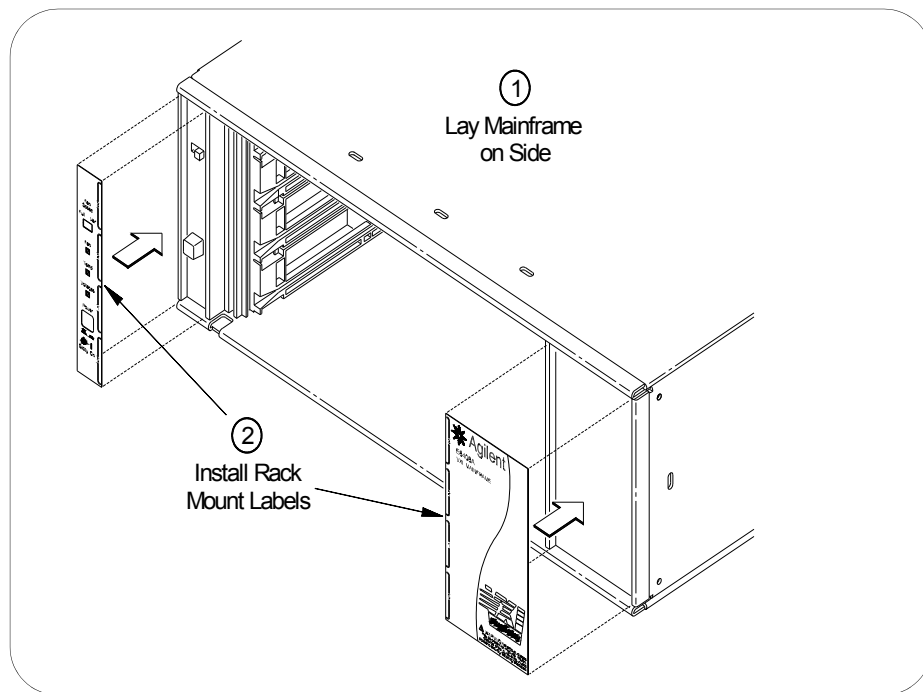

Figure 2-4. Installing Rack Mount Labels

### Attach Handles to Rack Mount Adapters (Figure 2-5)

- 1 Attach a handle to the LH Rack Mount Adapter using two 10-32 X 0.375" flat head screws.
- 2 Attach a handle to the RH Rack Mount Adapter using two 10-32 X 0.375" flat head screws.

---

**NOTE** *The rack mount adapter without the opening is the left-side (LH) Rack Mount Adapter and the rack mount adapter with the cable routing opening is the right-side (RH) Rack Mount Adapter.*

---

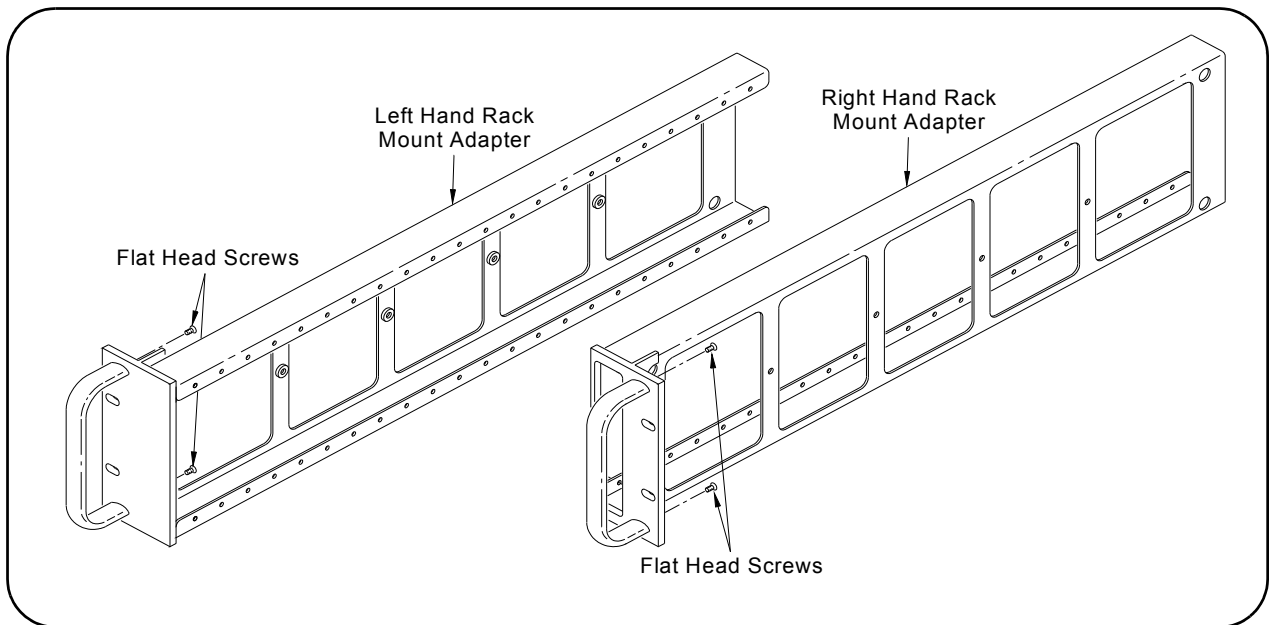

**Figure 2-5. Attaching Handles to the Rack Mount Adapters**

## Attach Rack Mount Adapters to Mainframe (Figure 2-6)

**NOTE** *The mainframe can be recess mounted up to 207 mm (approximately 8 inches) in 23 mm (approximately 1 inch) increments. When recessing the mainframe, make sure that six screws are used to attach the adapters on each side.*

*For mass interconnect systems, the mainframe must generally be recessed. Check the mass interconnect system manufacturer's instructions BEFORE attaching the adapters to the mainframe.*

*For easier installation, place the screws in the openings before you begin attaching the adapters.*

- 1 Attach the LH Rack Mount Adapter to the left side of the mainframe using six M3 X 0.5 pan head screws.
- 2 Attach the RH Rack Mount Adapter to the right side of the mainframe using six M3 X 0.5 pan head screws.

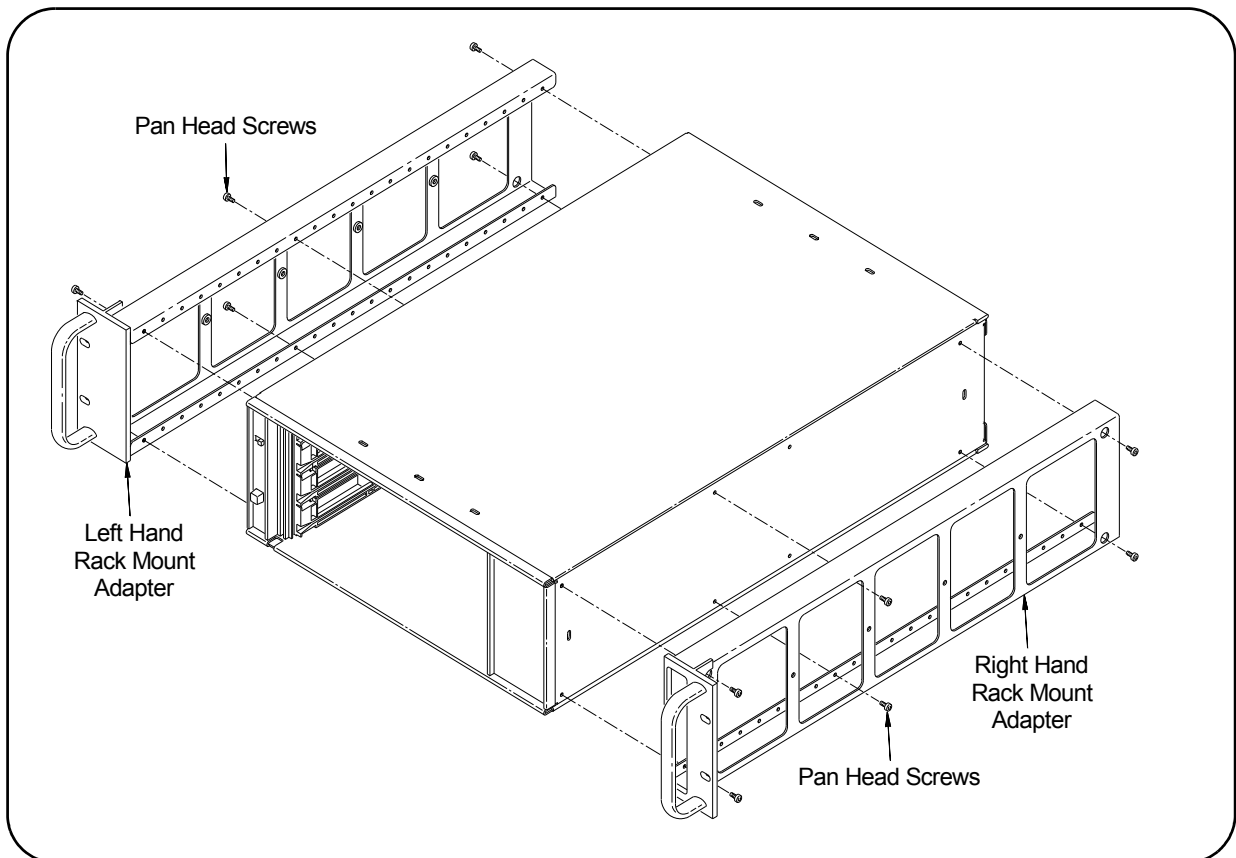

**Figure 2-6. Attaching the Rack Mount Adapters to the Mainframe.**

## Set Up Rack Cabinet Remove Rack Slide Chassis Sections (Figure 2-7)

- 1 Open the Rack Slide Kit (1494-0413).
- 2 Remove the Left-Side (LH) Rack Slide Chassis Section from the Intermediate Section.
- 3 Slide the Intermediate Section back into the Stationary Section.
- 4 Remove the Right-Side (RH) Rack Slide Chassis Section from the Intermediate Section.
- 5 Slide the Intermediate Section back into the Stationary Section.

---

**NOTE** *Be sure to mark the chassis sections as RH or LH so you can install them on the proper side of the Rack Mount Adapters. (The Rack Slide is marked with - RH or - LH on the label to identify it.)*

---

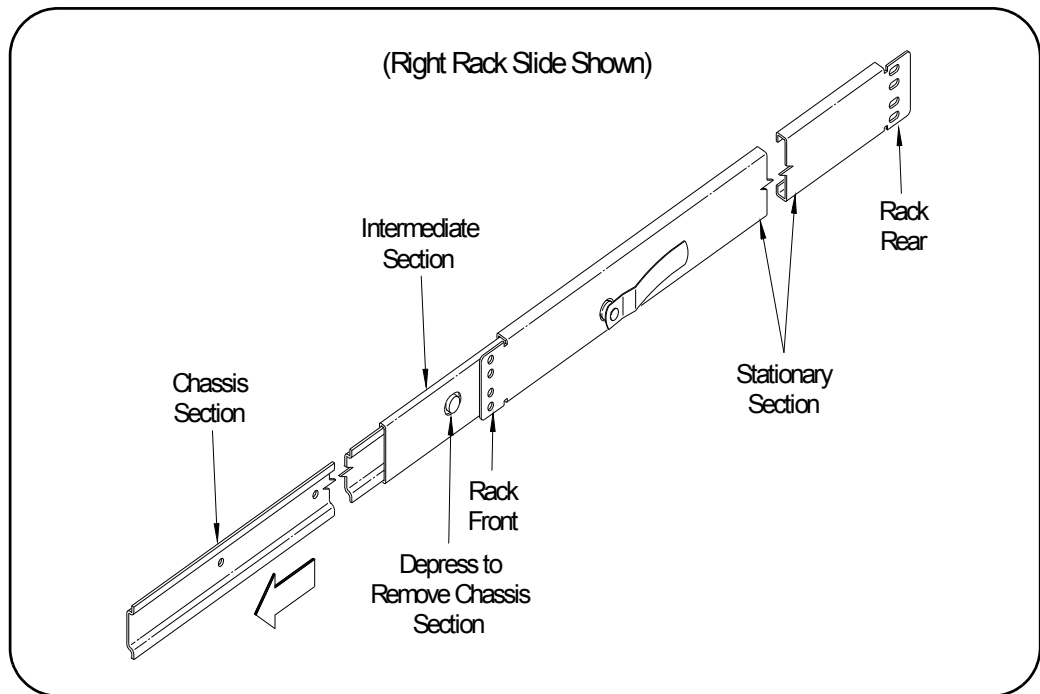

**Figure 2-7. Removing Rack Slide Chassis Section**

### Connect Chassis Section to Rack Mount Adapters (Figure 2-8)

- 1 Connect the LH Rack Slide chassis section to the LH Rack Mount Adapter using four 10-32 x 0.375" pan head screws.
- 2 Connect the RH Rack Slide chassis section to the RH Rack Mount Adapter using four 10-32 x 0.375" pan head screws.

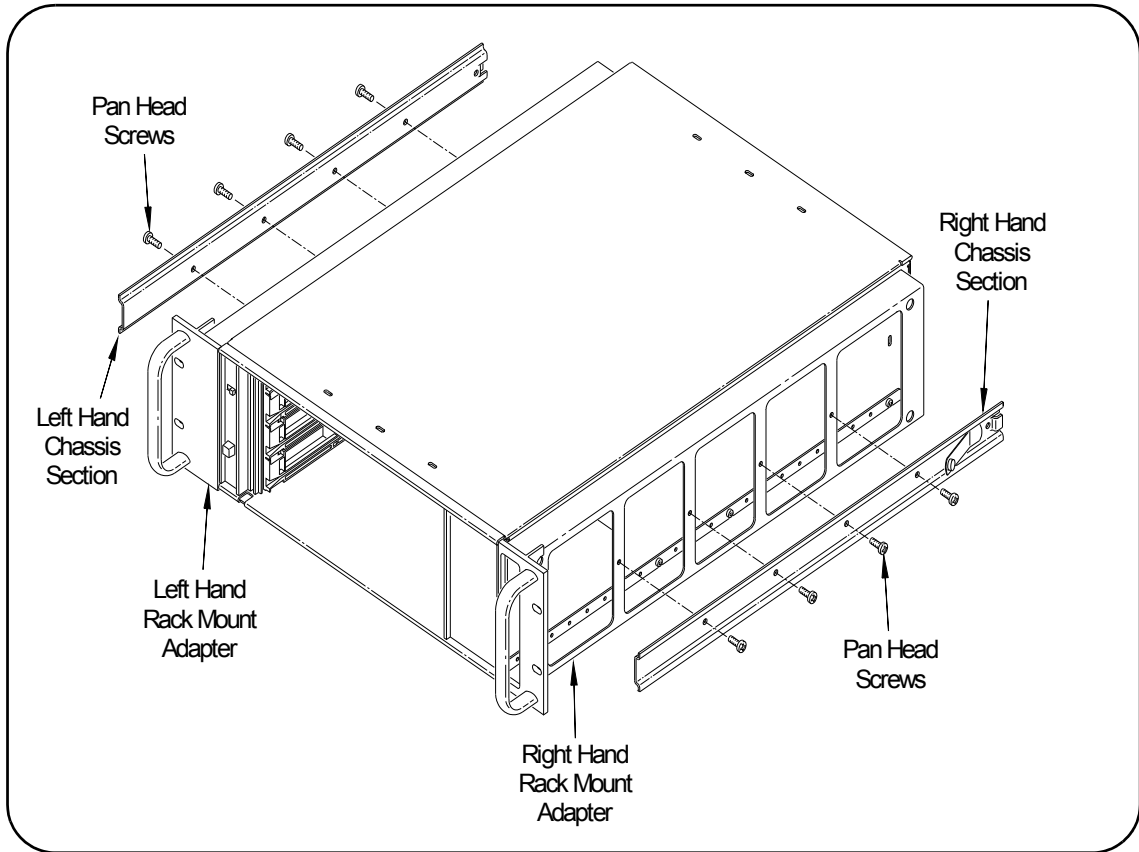

Figure 2-8. Connecting Chassis Section to Rack Mount Adapters

### Install Channel Nuts for Rack Mount Adapters (Figure 2-9)

- 1 Determine the location for the mainframe in the cabinet. The E8408A mainframe requires 3 EIA Units, and should be placed between the EIA markers.
- 2 Select the holes for the LH and RH Rack Mount Adapters. See Figure 2-9 for the RH Rack Mount Adapter hole locations. (LH Rack Mount Adapter hole locations are the same.)
- 3 Slide two 10-32 Self-Retained Nuts (provided in the Rack Mount/ Cable Route Adapter Kit) over the selected holes in the right hand front vertical column of the cabinet. These nuts will be used to connect the RH Rack Mount Adapter.
- 4 Slide two 10-32 Self-Retained Nuts over the selected holes in the left hand front vertical column of the cabinet. These nuts will be used to connect the LH Rack Mount Adapter.

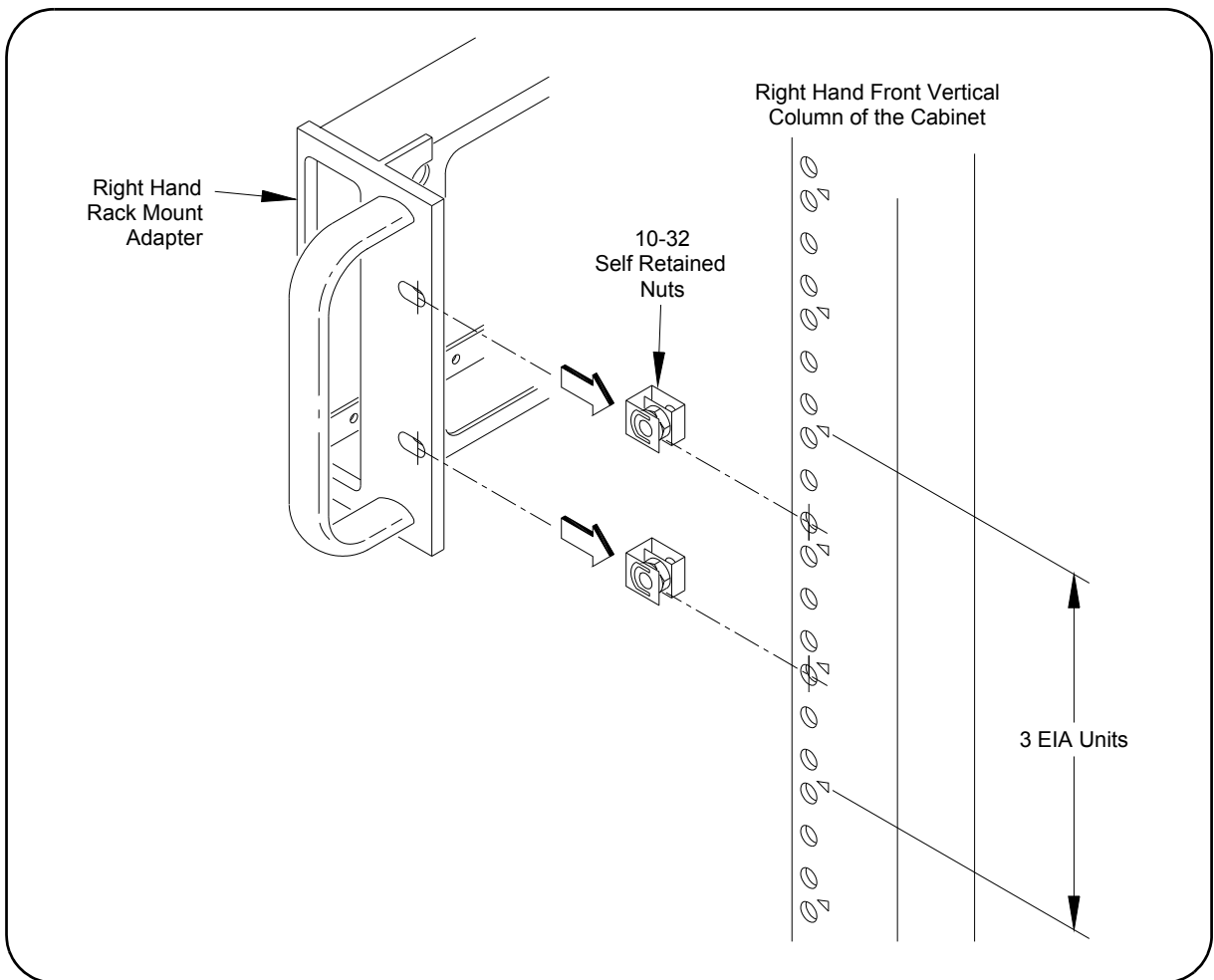

Figure 2-9. Installing Rack Mount Adapter Channel Nuts

## Install Rack Slide Stationary Sections (Figure 2-10)

**NOTE** For non-cabinets, you must add End Brackets (1494-0061) to the Rack Slide Kit (1494-0413). See the instructions for the 1494-0061 kit to install the rack slides.

The Rack Slides occupy the center EIA unit of the three EIA units required for the E8408A mainframe.

- 1 Slide four 10-32 Self-Retained Nuts on the selected holes in the right hand vertical column of the cabinet. See Figure 2-10 for hole locations.
- 2 Attach the RH Rack Slide Stationary Section to the right hand vertical column of the cabinet. Use two 10-32 x 0.5" flat head screws at the front of the rack slide, and two 10-32 x 0.375" pan head screws at the rear of the rack slide.
- 3 Repeat steps for the LH Rack Slide Stationary Section.

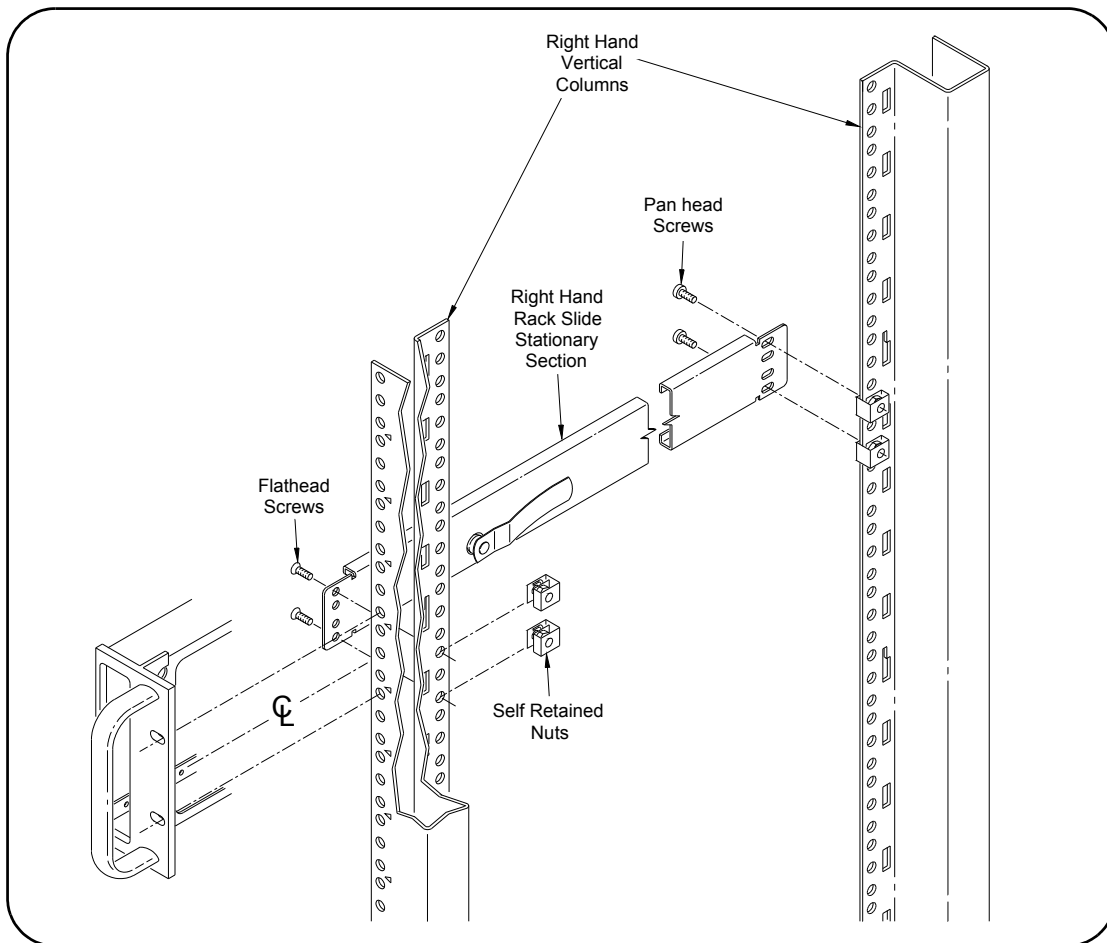

Figure 2-10. Installing Rack Slide Stationary Sections

## Installing the Mainframe    Install the Mainframe in the Rack (Figure 2-11)

- 1 Slide the Rack Slide Intermediate Sections out from the Rack Slide Stationary Sections until they lock into place.

---

**WARNING**    To prevent possible injury during rack mounting, two people should lift the mainframe into the rack.

---

- 2 With one person on each side, lift the mainframe and slide the Chassis Sections into the Intermediate Sections until the Chassis Sections lock into place.
- 3 Slide the mainframe into the cabinet until the Rack Mount Adapter flanges are against the front vertical columns of the cabinet. (You will need to depress the Chassis Section Slide Locks twice to fully slide the mainframe to the columns.)
- 4 Secure the mainframe to the rack using the four adapter dress screws.

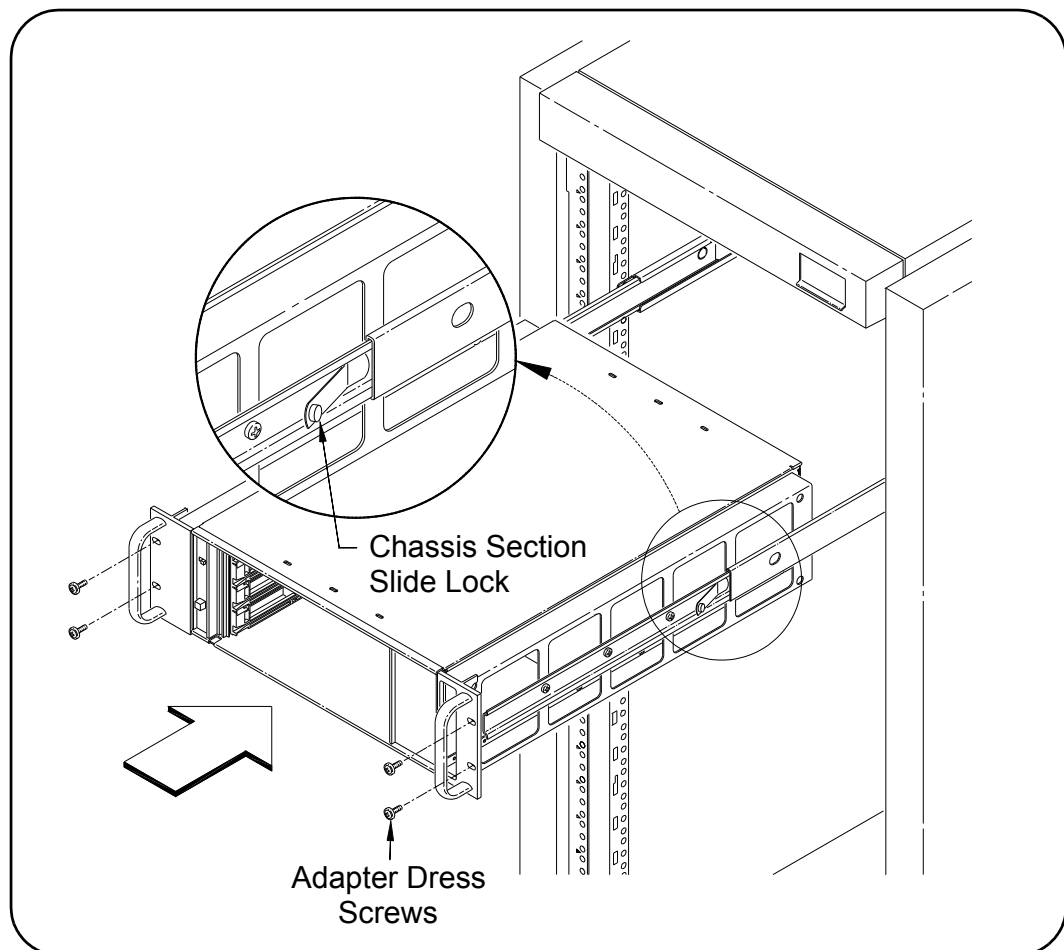

Figure 2-11. Installing the Mainframe



### Connect/Route VXI Instrument Cables (Figure 2-12)

- 1 As required, install VXI instruments in the mainframe (See *Chapter 1 - Getting Started*).
- 2 Connect cable(s) to instrument front panel terminals as required.
- 3 Route cables through the right side cable tray/RH Rack Mount Adapter, as required.

---

**NOTE** *Cables should not be routed on the left side of the mainframe as the cables may interfere with proper airflow.*

---

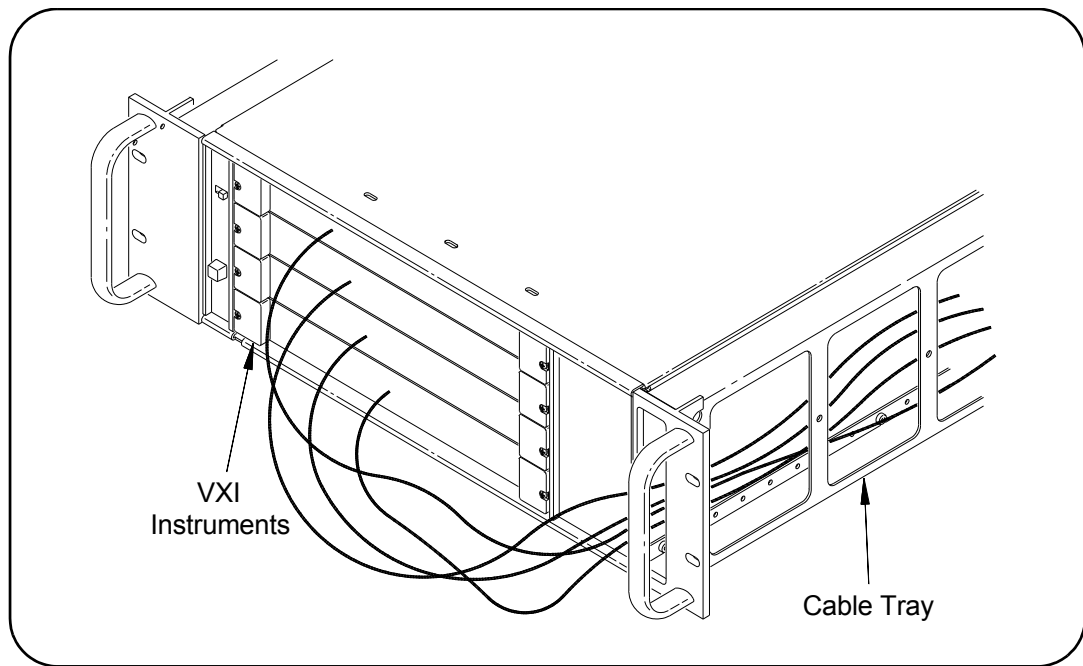

**Figure 2-12. Routing VXI Instrument Cables**

# Rack Mounting Using Support Rail Kit

This section contains instructions to mount the E8408A mainframe in a standard EIA cabinet using the Rack Mount/Cable Route Adapter Kit (E8397A) and the E3663A Support Rail Kit (E3663A). The E3663A is only compatible with standard EIA cabinets.

**Parts List** Table 2-3 shows the parts for the Standard Rack Mount/Cable Routing Kit and the Support Rails Kit

**Table 2-3. Rack Mount Kit and Support Rail Kit Parts Lists**

Quantity	Description	Part Number
<b>Rack Mount/Cable Route Adapter Kit (E8397A)</b>		
1	Rack Mount Adapter (right)	E8408-61200
1	Rack Mount Adapter (left)	E8408-61201
2	Handle (for Rack Mount Adapters)	RAF p/n 8344-1032-A34
4	10-32 X 0.375" Flat Head Screw (Handle Screws)	2680-0100
12	M3 X 0.5 Pan Head Screw (Adapter-to Mainframe Screws)	0515-0372
4	Adapter Dress Screw	0570-1577
4	Self-Retained Nut (for Rack Mount Adapters)	0590-0804
1	Front Panel Label Set (Rack-Mount Orientation)	E8408-84305
<b>Support Rail Kit (E3663A)</b>		
2	Support Rail	E3663-00001
4	10-32 Self-Retained Nut	0590-0804
4	10-32 X 0.5" Pan Head Screw	2680-0278

**Installation Procedure** There are three main steps to rack mount the E8408A mainframe using the Rack Mount/Cable Route Adapter Kit (E8397A) and the Support Rail Kit (E3663A):

- Configure the Mainframe
- Set up Cabinet Racks
- Install the Mainframe

## Configure the Mainframe Remove Mainframe Items (as applicable) (Figure 2-13)

- 1 Remove the carrying handle/carrying strap.
- 2 Remove the two protective bumpers.
- 3 Remove the Accessory Pouch.

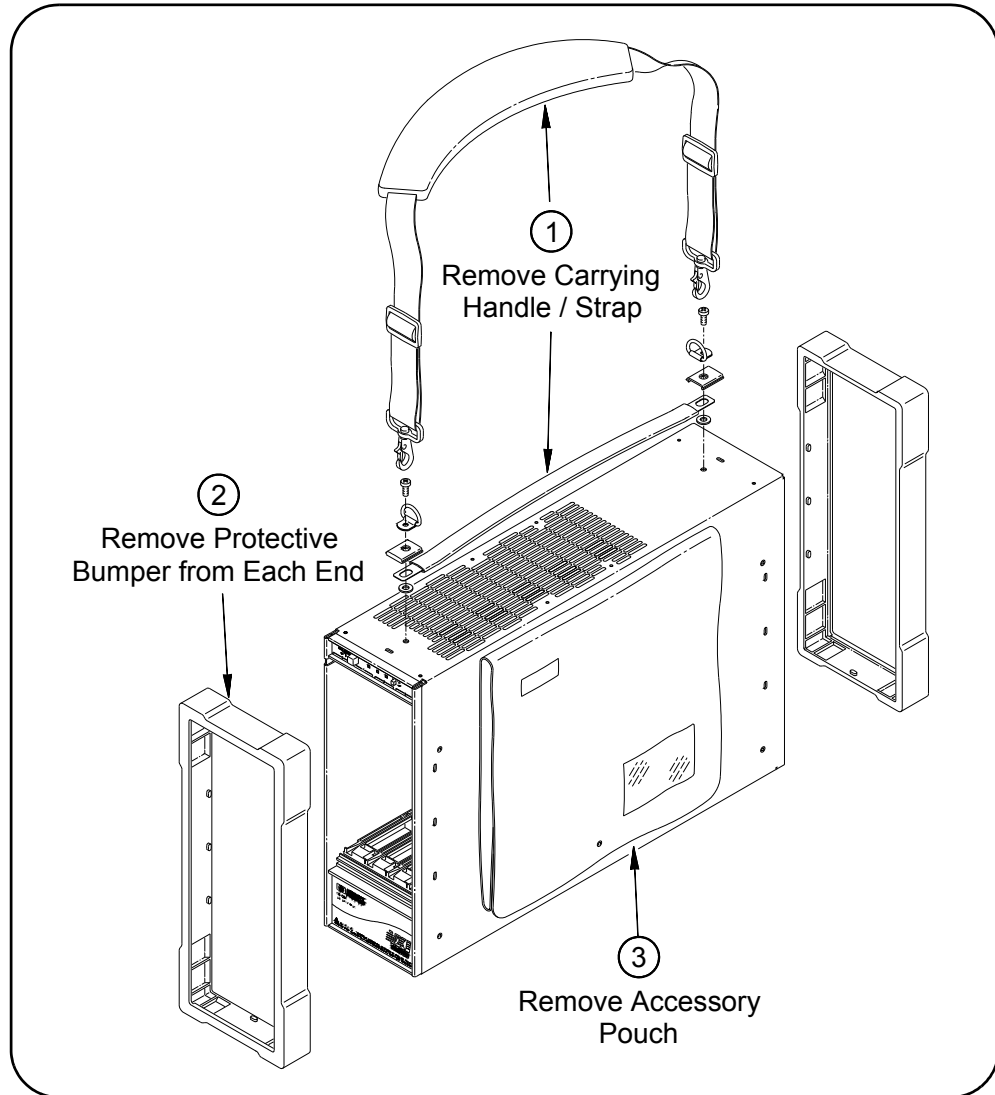

Figure 2-13. Removing Mainframe Items

### Install Rack Mount Labels (Figure 2-14)

- 1 Lay mainframe on its left side.
- 2 Open the Rack Mount/Cable Route Adapter Kit (E8397A).
- 3 Peel the protective backing from the two rack-mount front panel labels (in the E8397A kit) and carefully place them over the existing labels. Press to adhere.

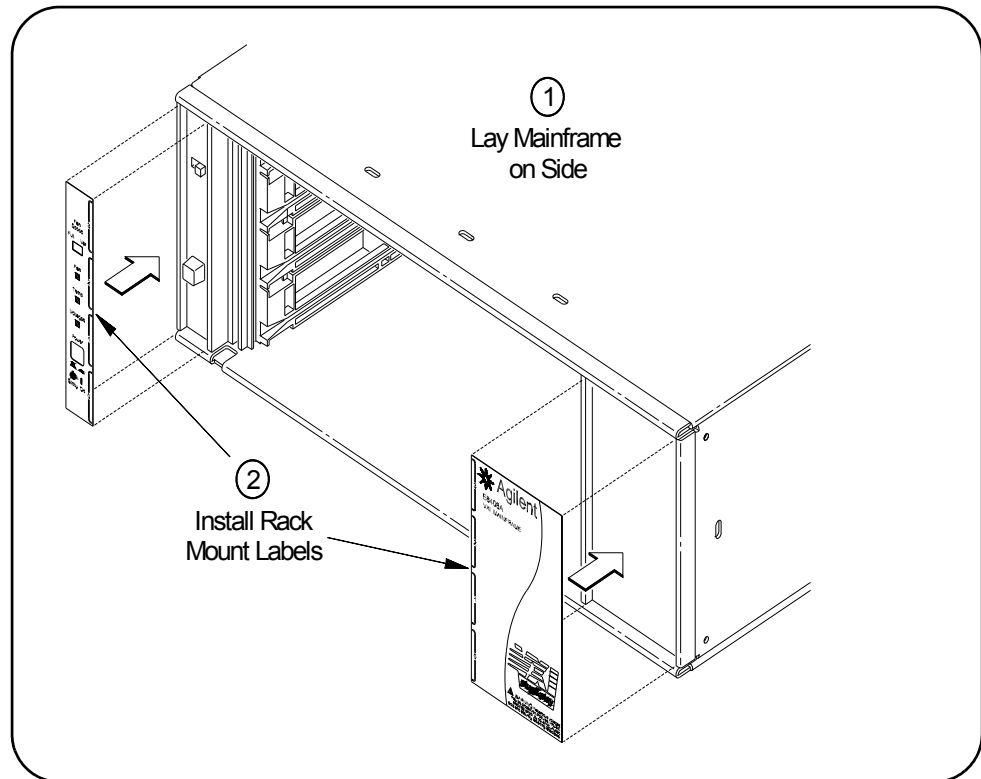

Figure 2-14. Installing Rack Mount Labels

### Attach Handles to Rack Mount Adapters (Figure 2-15)

- 1 Attach a handle to the LH Rack Mount Adapter using two 10-32 X 0.375" flat head screws.
- 2 Attach a handle to the RH Rack Mount Adapter using two 10-32 X 0.375" flat head screws.

---

**NOTE** *The rack mount adapter without the opening is the left-side (LH) Rack Mount Adapter, and the rack mount adapter with the cable routing opening is the right-side (RH) Rack Mount Adapter.*

---

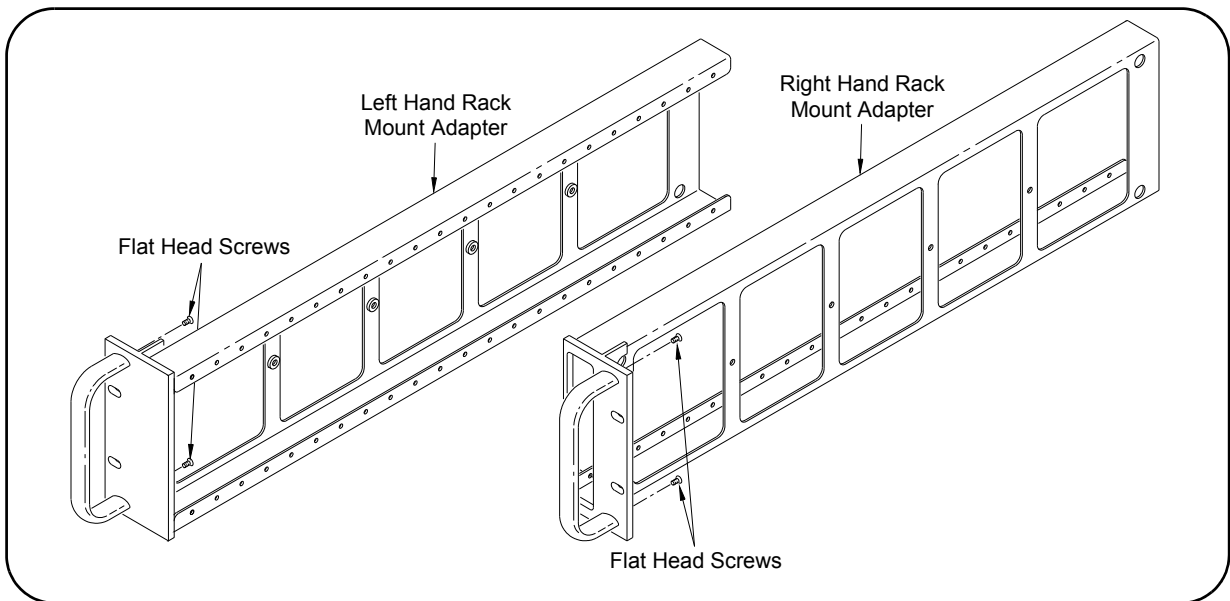

**Figure 2-15. Attaching Handles to the Rack Mount Adapters**

## Attach Rack Mount Adapters to Mainframe (Figure 2-16)

**NOTE** *The mainframe can be recess mounted up to 207 mm (approximately 8 inches) in 23 mm (approximately 1 inch) increments. When recessing the mainframe, make sure that six screws are used to attach the adapters on each side.*

*For mass interconnect systems, the mainframe must generally be recessed. Check the mass interconnect system manufacturer's instructions BEFORE attaching the adapters to the mainframe.*

*For easier installation, place the screws in the openings before you begin attaching the adapters.*

- 1 Attach the LH Rack Mount Adapter to the left side of the mainframe using six M3 X 0.5 pan head screws.
- 2 Attach the RH Rack Mount Adapter to the right side of the mainframe using six M3 X 0.5 pan head screws.

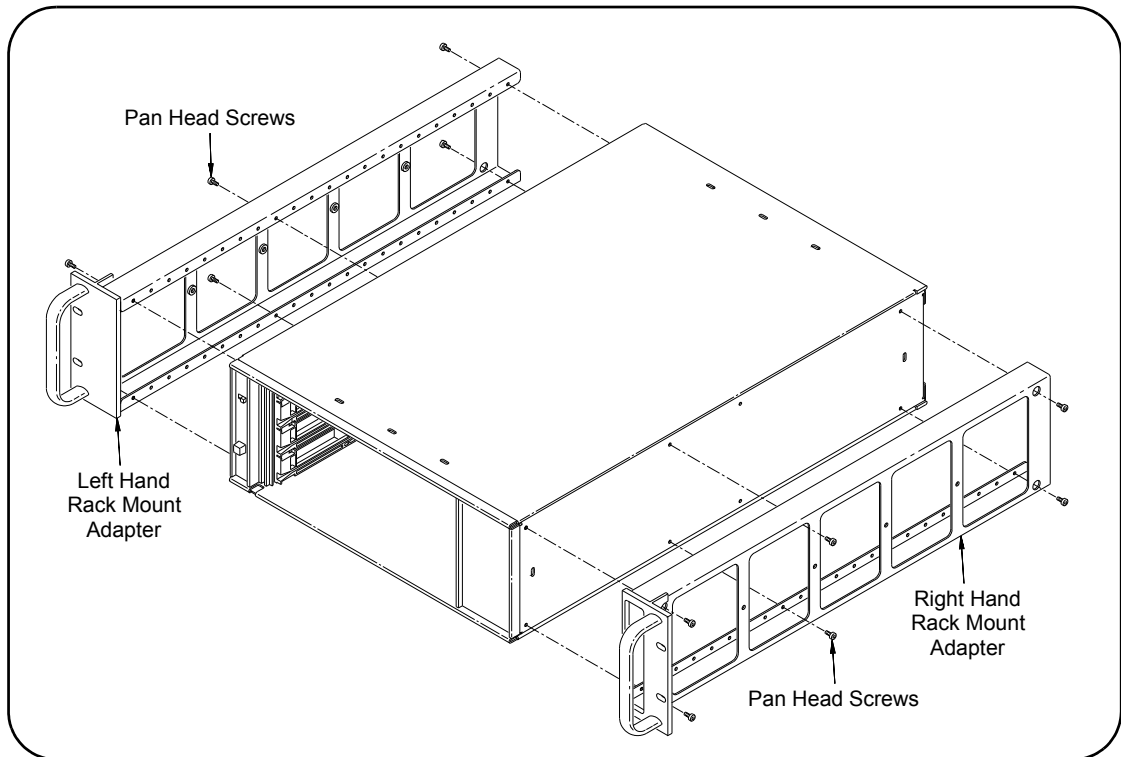

**Figure 2-16. Attaching the Rack Mount Adapters to the Mainframe.**

## Set Up Rack Cabinet    Install Channel Nuts for Rack Mount Adapters (Figure 2-17)

- 1 Determine the location for the mainframe in the cabinet. The E8408A mainframe requires 3 EIA Units, and should be placed between the EIA markers.
- 2 Select the holes for the LH and RH Rack Mount Adapters. See Figure 2-17 for the RH Rack Mount Adapter hole locations. (LH Rack Mount Adapter hole locations are the same.)
- 3 Slide two 10-32 Self-Retained Nuts (provided in the Rack Mount/Cable Route Adapter Kit) over the selected holes in the right hand front vertical column of the cabinet. These nuts will be used to connect the RH Rack Mount Adapter.
- 4 Slide two 10-32 Self-Retained Nuts over the selected holes in the left hand front vertical column of the cabinet. These nuts will be used to connect the LH Rack Mount Adapter.

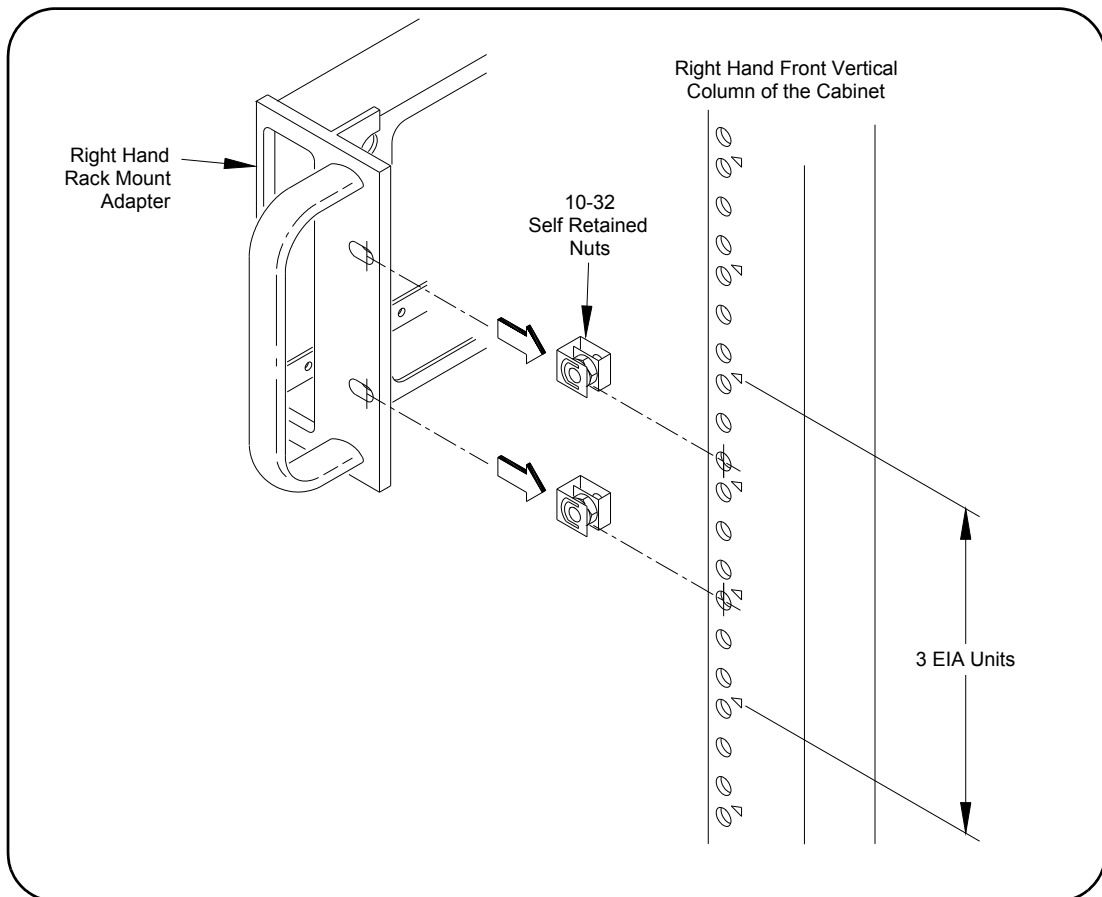

Figure 2-17. Installing Rack Mount Adapter Channel Nuts

## Install Support Rails (Figure 2-18)

- 1 Open the Support Rail Kit (E3663A).
- 2 Hook the Support Rails in position in the Rack Cabinet. The Support Rails occupy the bottom EIA unit of the three units required for the E8408A mainframe.
- 3 Slide a 10-32 Self-Retained Nut (provided in the Support Rail Kit) over the appropriate holes in the front and rear right hand vertical columns in the cabinet. Repeat for the left hand vertical columns.
- 4 Secure each Support Rail to the columns as shown in Figure 2-18.

---

**WARNING**

**To avoid possible injury or equipment damage, always secure the Support Rails with mounting screws before installing equipment.**

---

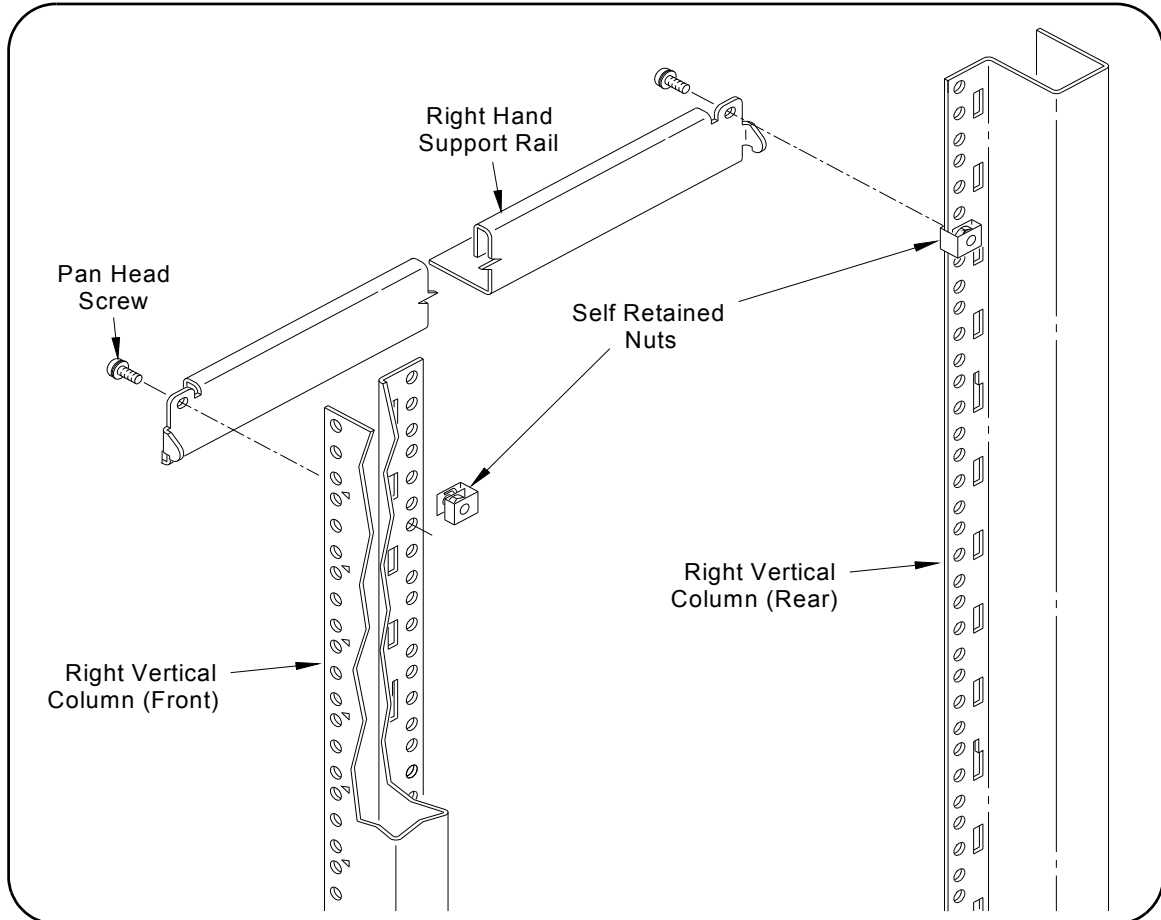

**Figure 2-18. Installing Support Rails**



## Installing the Mainframe    Install the Mainframe in the Rack Cabinet (Figure 2-19)

- 1 With one person on each side, lift the mainframe and slide the mainframe fully onto the Support Rails.

---

**WARNING**    To prevent possible injury during rack mounting, two people should lift the mainframe into the rack.

---

- 2 Slide the mainframe into the rack until the Rack Mount Adapter flanges are against the rack's front vertical columns.
- 3 Secure the mainframe to the rack using the four adapter dress screws.

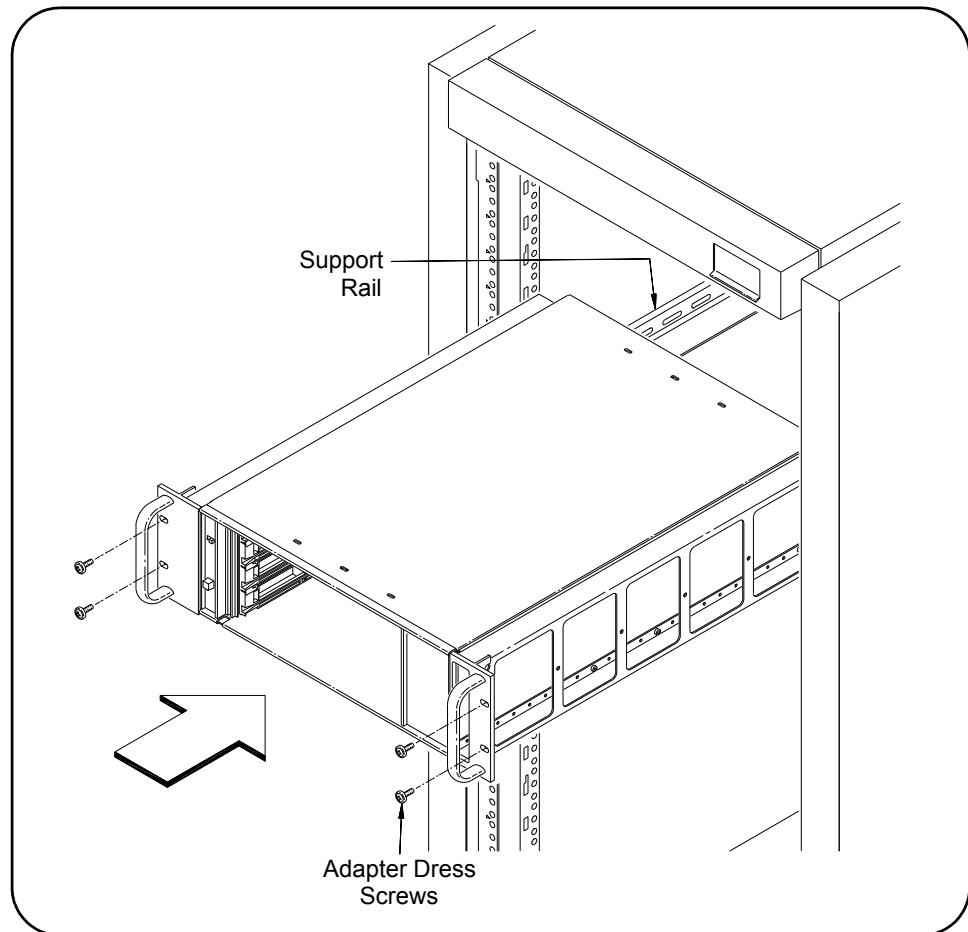

Figure 2-19. Installing the Mainframe

### Connect/Route VXI Instrument Cables (Figure 2-20)

- 1 As required, install VXI instruments in the mainframe (See *Chapter 1 - Getting Started*).
- 2 Connect cable(s) to instrument front panel terminals as required.
- 3 Route cables through the right side cable tray/RH Rack Mount Adapter, as required.

---

**NOTE** *Cables should not be routed on the left side of the mainframe as the cables may interfere with proper airflow.*

---

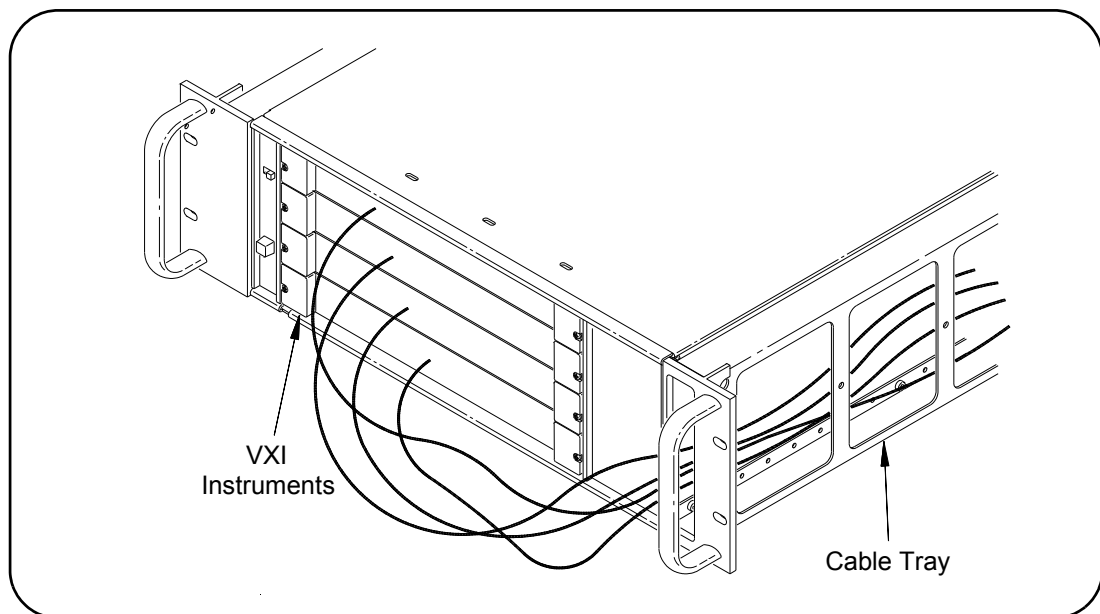

**Figure 2-20. Routing VXI Instrument Cables**

# Installing Intermodule Chassis Shields

This section describes how to install Intermodule Chassis Shields (E8400-80919) in the E8408A mainframe. The chassis shield is the implementation of VXI revision 1.4, specification B.7.3.4 that allows grounded shielding between mainframe slots. The shield is used to isolate VXI modules that generate electromagnetic interference (EMI) at excessive levels, or to protect VXI measurement modules from noise sources.

---

**WARNING** Do not install intermodule chassis shields while the mainframe is turned on or plugged into an AC power source.

---

**Parts List** The parts included in the E8400-80919 kit are shown in Table 2-4.

**Table 2-4. E8408-80919 Parts List.**

Quantity	Description	Part Number
1	Chassis Shield	E8400-00600
8*	Grounding Spring	E8400-09101

\* Includes 4 extra springs.

## Installation Procedure

Each mainframe slot has top and bottom chassis shield guides (Figure 2-21). Chassis shields should be installed on both sides of an instrument generating interference/noise, or installed on both sides of a sensitive instrument.

- 1 **Insert Grounding Springs.** Insert grounding springs into the four sockets (two top, two bottom) along the shield guides. Use a small flat blade screwdriver to secure each spring under the socket tab.

---

**NOTE** Use the chassis shield to cover the vent holes inside the mainframe when installing grounding springs in the top guide sockets. This prevents the springs from falling into the mainframe if they are accidentally dropped.

---

- 2 **Install the Chassis Shield.** Align the chassis shield with the shield guides and gently slide the shield into the mainframe. Be careful not to crimp the front grounding springs with the edge of the shield. Slide the shield in until it reaches the end of the shield guide.

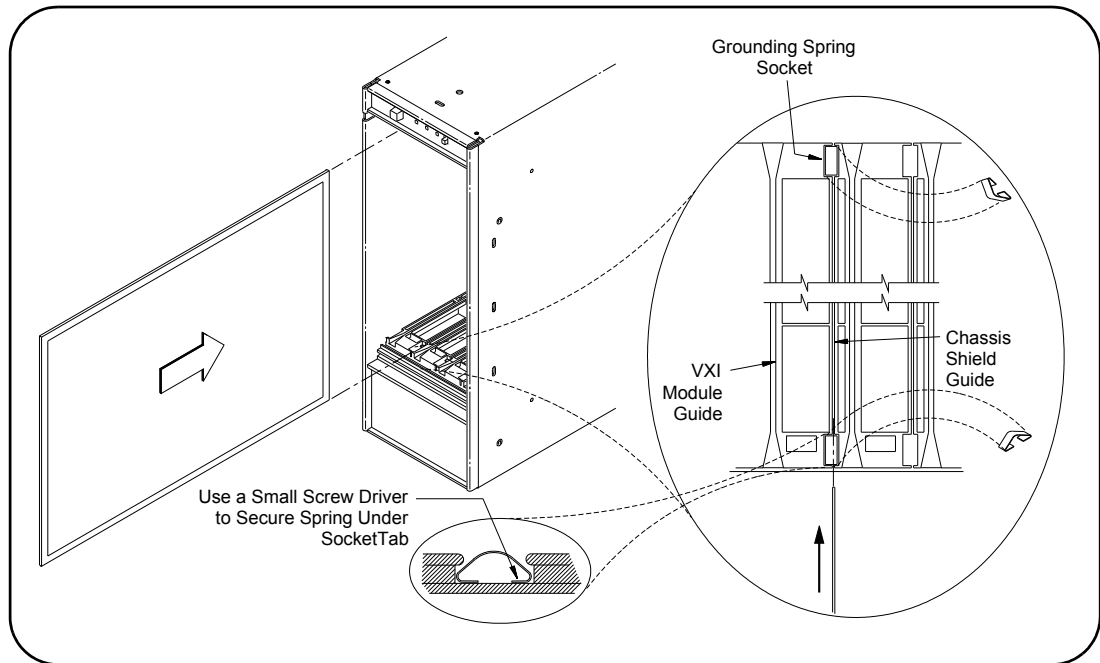

Figure 2-21. Installing the Grounding Springs and Chassis Shield.

## Installing Backplane Connector Shields

This section describes how to install backplane connector shields (E8408-80900) in the E8408A mainframe. The shields are the implementation of VXI revision 2.0, specification B.7.2.3 which ensures compliance with RFI levels specified in standards EN55011 and CISPR11.

A number of VXI instruments require shields for compliance with EN55011 and CISPR11. Refer to the instrument documentation to determine if shields are required.

### WARNING

**Do not install backplane connector shields while the mainframe is turned on or plugged into an AC power source.**

### Parts List

The parts included in the E8408-80900 kit are shown in Table 2-5.

Table 2-5. E8408-80900 Parts List.

Quantity	Description	Part Number
18*	Pan Head Screw - 4-20 x .25	0624-0702
8	Backplane Connector Shield	E1400-80601

\* Includes two extra screws

## Installation Procedure

- 1 **Position Shields.** Position the shields over the backplane connectors as shown in Figure 2-22. Two connector shields and four screws are required for each slot.
- 2 **Install Screws.** To install the screws, firmly press the screw onto a driver. This prevents the screw from falling off as you reach into the mainframe. Placing a sheet of paper under the backplane connectors will catch screws if they fall.
- 3 **Tighten Screws.** Tighten the screws by turning them clockwise. The screws are thread-forming and will go in slowly when you install them the first time.

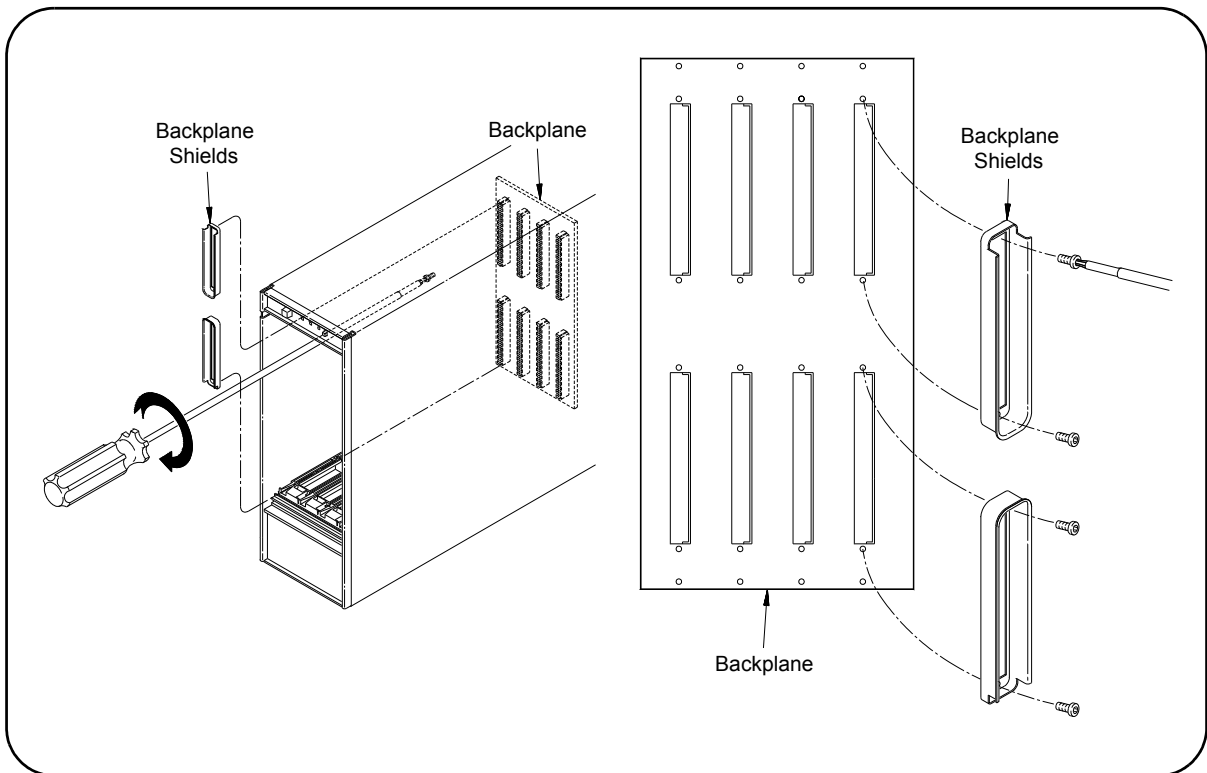
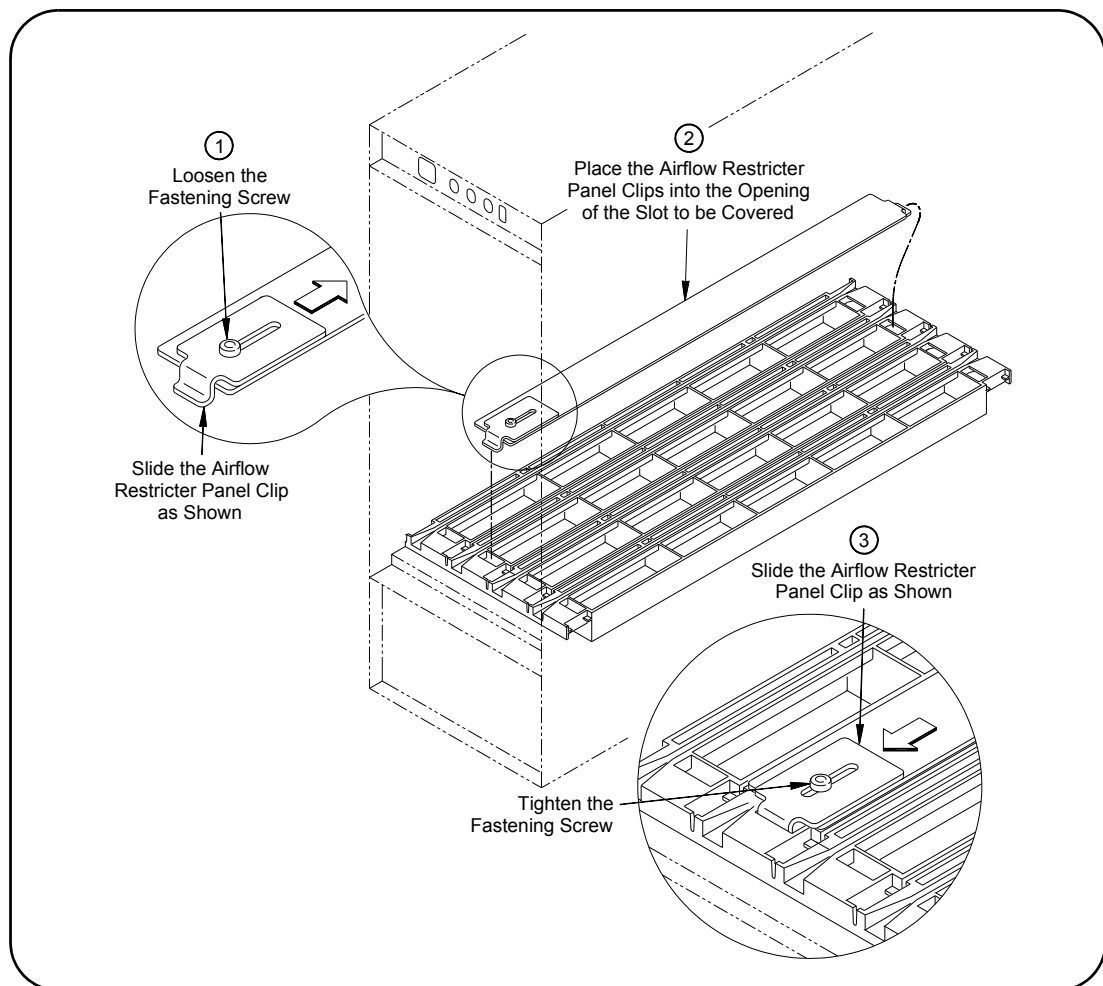

Figure 2-22. Positioning the Backplane Shields on the Connectors.

# Installing the Airflow Restrictor Kit

This section shows how to install an (optional) airflow restrictor kit (E8400-80917) in the E8408A mainframe. To install the kit:

- 1 Disconnect AC power from the mainframe and place mainframe on bench.
- 2 As required, remove filler panels and/or installed VXI instruments from the mainframe.
- 3 Follow the steps in Figure 2-23 to install the Airflow Restrictor.



**Figure 2-23. Installing the Airflow Restrictor**

**Notes:**

---

# Chapter 3

## Servicing the Mainframe

---

### Chapter Overview

This chapter contains information for troubleshooting and replacing selected components of the E8408A VXI mainframe. This chapter includes the following information:

- Replaceable Parts List ..... 45
- Problem Isolation ..... 46
- Replacing Mainframe Components ..... 46
- Cleaning Instructions ..... 53

**WARNING**

---

**There are no user-serviceable parts inside the mainframe. Repair is limited to replacement of the components listed in Table 3-1. Replacement of these components must be performed at a static-controlled workstation by trained service personnel only.**

---

### Replaceable Parts List

These replacement parts are available from Agilent under the part numbers shown in Table 3-1. Contact Agilent to obtain replacement parts.

**Table 3-1. E8408A Replaceable Part Numbers**

Component	Part Number
Power Supply Assembly (includes Power Supply and E8408-66503 Interconnect Board) (Standard)	E8408-69005 (remanufactured)
Power Supply Assembly (includes Power Supply and E8408-66513 Interconnect Board) (Opt. 001)	E8408-69006 (remanufactured)
Monitor Board (E8408-66502)	E8408-66502
Fan Assembly	E8408-68500
Protective Bumper	E8408-86001
Front Panel Tapped Strip	E8408-21201



# Problem Isolation

Table 3-2 lists primary mainframe symptoms, possible cause(s), and suggested actions. Table 3-1 shows replacement part numbers.

**Table 3-2. Isolating Problems in the E8408A Mainframe**

Symptom	Possible Cause	Action
No mainframe power	Power Supply fuse blown or defective Power Supply	- There are <b>NO</b> replaceable power line fuses on mainframe. - If the mainframe power supply fails to operate, replace the Power Supply Assembly.
	Short between some supplies can latch the Power Supply OFF	- Switch to Standby mode, and then remove AC power. - Recovery can occur when AC power is reapplied and the mainframe <b>Power</b> switch is switched to ON. - If problem remains, replace Power Supply Assembly.
Flashing Voltages Indicator	Backplane voltage(s) may be incorrect	- Cycle mainframe <b>Power</b> switch. - Remove VXI instruments to ensure they are not the cause. - Check cable connections at Monitor and Backplane Board. - Replace Power Supply Assembly.
Flashing Temp Indicator	Power supply temperature is high.	- Mainframe is nearing automatic shutdown. - Check for proper air flow and clearance around the fan. - Check power requirements of installed VXI instruments. - Replace Fan Assembly as required. - Replace Power Supply Assembly as required.
Flashing Fan Indicator	Fan has failed or fan connection loose	- Turn off mainframe to avoid possible overheating. - Check fan connections to P3 on Backplane Board. - Replace Fan Assembly as required.
Monitor indicators and fan remain OFF when <b>Power</b> switch is pressed.	Defective Monitor Board (E8408-66502) or loose cable to Monitor Board	- Check cable connections at Monitor and Backplane Board. - Replace Monitor Board as required.
Slot 0 Card SYSFAIL Indicator	VXI Instrument failure	- The Slot 0 card (E1406A, E8491A, etc.) SYSFAIL indicator will turn ON and remain ON when a VXI instrument installed in the mainframe fails.

## Replacing Mainframe Components

This section gives guidelines to replace E8408A mainframe components, including:

- Removing Mainframe Accessory Items
- Removing the Mainframe Cover
- Replacing the Power Supply Assembly
- Replacing the Monitor Board
- Replacing the Fan Assembly
- Replacing the Front Panel Tapped Strip
- Replacement Power Cords

## Removing Mainframe Accessory Items

For some component removal/replacement, you may need to remove mainframe accessory items (as applicable) (see Figure 3-1)

- 1 Remove the carrying handle/carrying strap.
- 2 Remove the two protective bumpers.
- 3 Remove the Accessory Pouch.

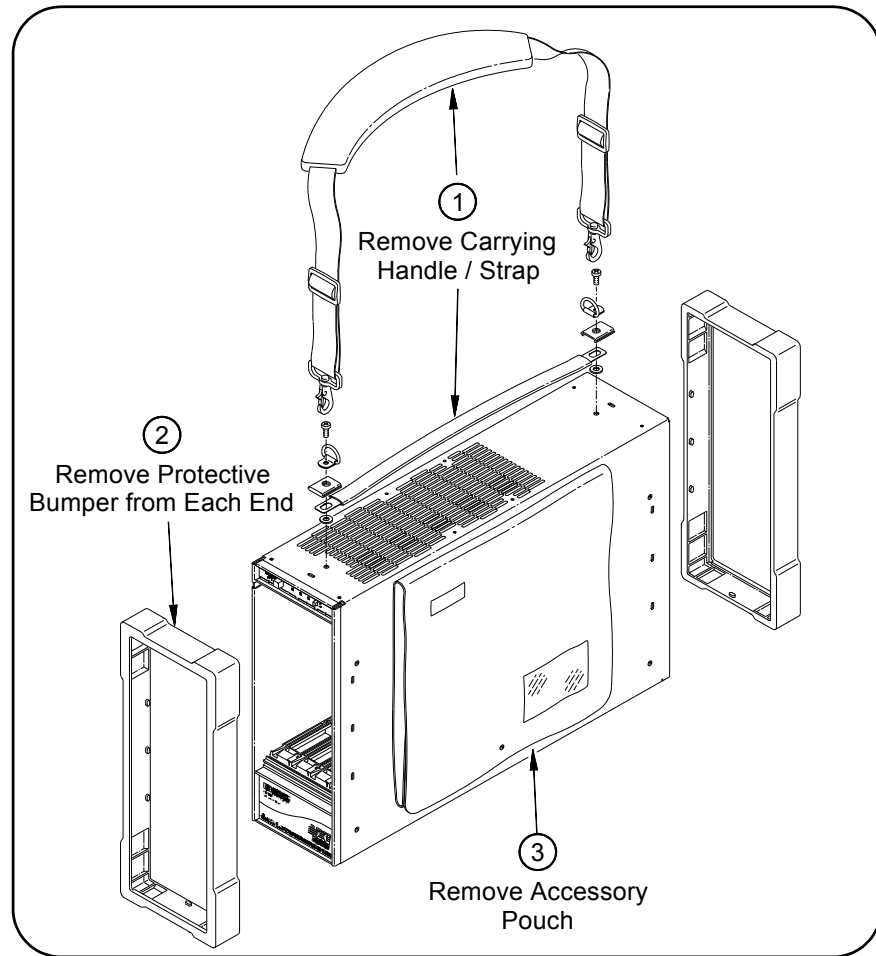

Figure 3-1. Removing Mainframe Accessory Items

## Removing the Mainframe Cover

For some component removal/replacement, you may need to remove mainframe cover (see Figure 3-2).

- 1 Turn off the mainframe and remove the AC power cord.
- 2 If mainframe is rack-mounted, remove the mainframe from the rack and place the mainframe at a static-controlled workstation.
- 3 Remove mainframe items as required. See "Removing Mainframe Items".
- 4 Remove the ten M3x6 flat head screws (five on each side of the mainframe).
- 5 Slide the mainframe cover toward the rear of the mainframe, and then lift the mainframe cover off the mainframe.

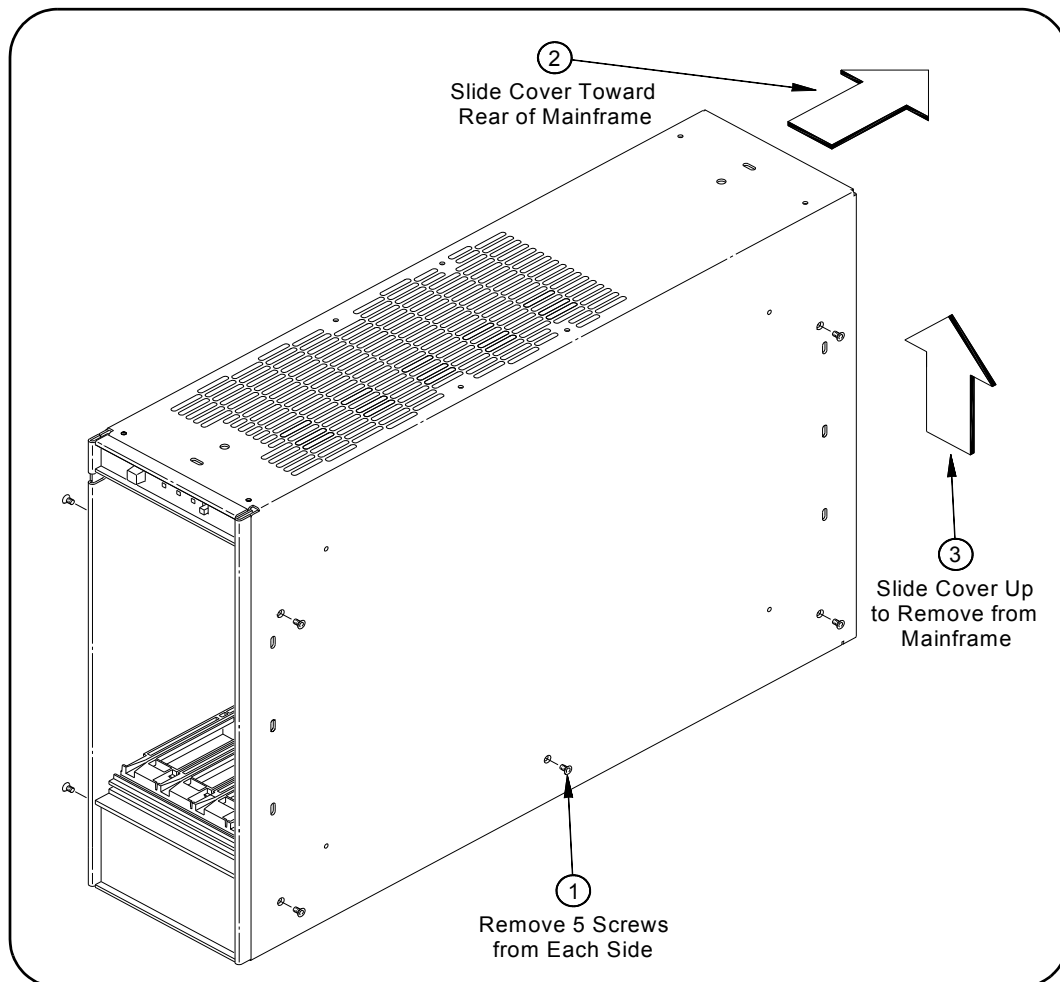

Figure 3-2. Removing the Mainframe Cover

## Replacing the Power Supply Assembly

This section gives guidelines to replace the Power Supply Assembly (E8408-69005 [Standard] or E8408-90006 [Option 001]) in the E8408A mainframe (see Figure 3-3).

**NOTE** *Although the Power Supply Assembly contains the power supply and the Interconnect Board, do NOT remove the Power Supply or the Interconnect Board from the Assembly. Return the entire Power Supply Assembly to Agilent for a (remanufactured) Power Supply Assembly. See Table 3-1 for replacement part numbers.*

*Be sure to observe static-free procedures when removing/installing the Power Supply Assembly.*

- 1 Turn off mainframe power and remove the AC power cord.
- 2 Follow the steps in Figure 3-3 to remove the Power Supply Assembly.
- 3 Reverse the steps in Figure 3-3 to replace the Power Supply Assembly and to restore the mainframe to its original configuration.

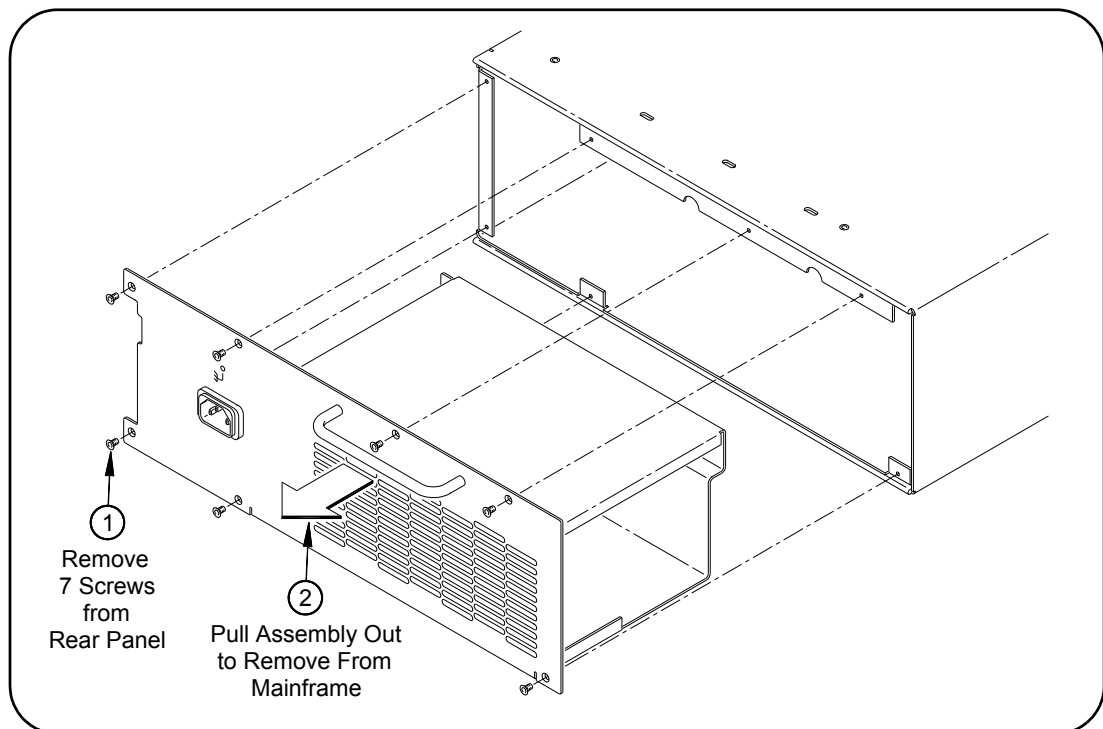

**Figure 3-3. Removing the Power Supply Assembly**

## Replacing the Monitor Board

This section gives guidelines to replace the Monitor Board (E8408-66502). See Table 3-1 for a replacement part number.

- 1 Turn off the mainframe and remove the AC power cord.
- 2 If the mainframe is rack-mounted, remove the mainframe from the rack and place the mainframe at a static-controlled workstation.
- 3 Remove mainframe option items as required. See "Removing Mainframe Accessory Items".
- 4 Remove the mainframe cover. See "Removing the Mainframe Cover".
- 5 Follow the steps in Figure 3-4 to disconnect the ribbon cable and to remove the Monitor Board.
- 6 Reverse the steps in Figure 3-4 to install a replacement Monitor Board and to re-connect the ribbon cable.
- 7 Replace the mainframe cover by reversing the steps in "Removing the Mainframe Cover".
- 8 Reinstall mainframe options removed in step 3 OR reinstall the mainframe in the rack (as required). Reconnect the AC power cord.

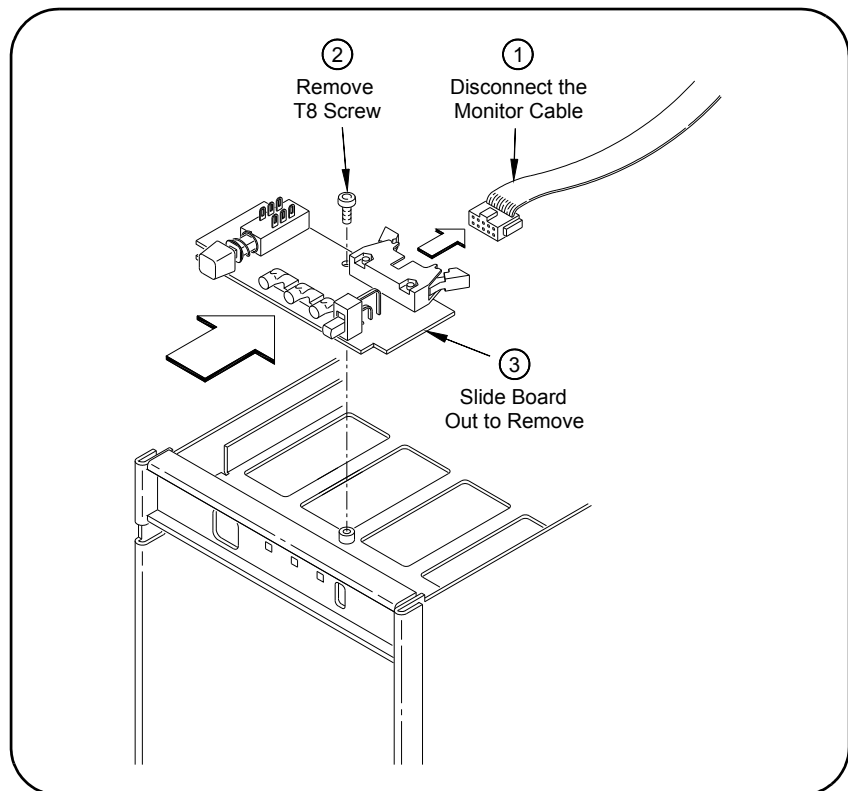

Figure 3-4. Removing the Monitor Board

# Replacing the Fan Assembly

This section gives guidelines to replace the Fan Assembly in the E8408A mainframe (see Figure 3-5). See Table 3-1 for a replacement part number.

- 1 Turn off the mainframe and remove the AC power cord.

---

**NOTE** *Be sure to observe static-free procedures when removing/installing the Fan Assembly.*

---

- 2 Remove mainframe accessory items as required. See "Removing Mainframe Accessory Items".
- 3 Remove the Power Supply Assembly. See "Replacing the Power Supply Assembly".
- 4 Remove the Fan Assembly by following the steps in Figure 3-5.
- 5 Install the replacement fan assembly by reversing the steps in Figure 3-5.
- 6 Reinstall the Power Supply Assembly by reversing the steps in "Replacing the Power Supply Assembly".
- 7 Reinstall mainframe accessory items removed in step 2. Reconnect AC power cord.

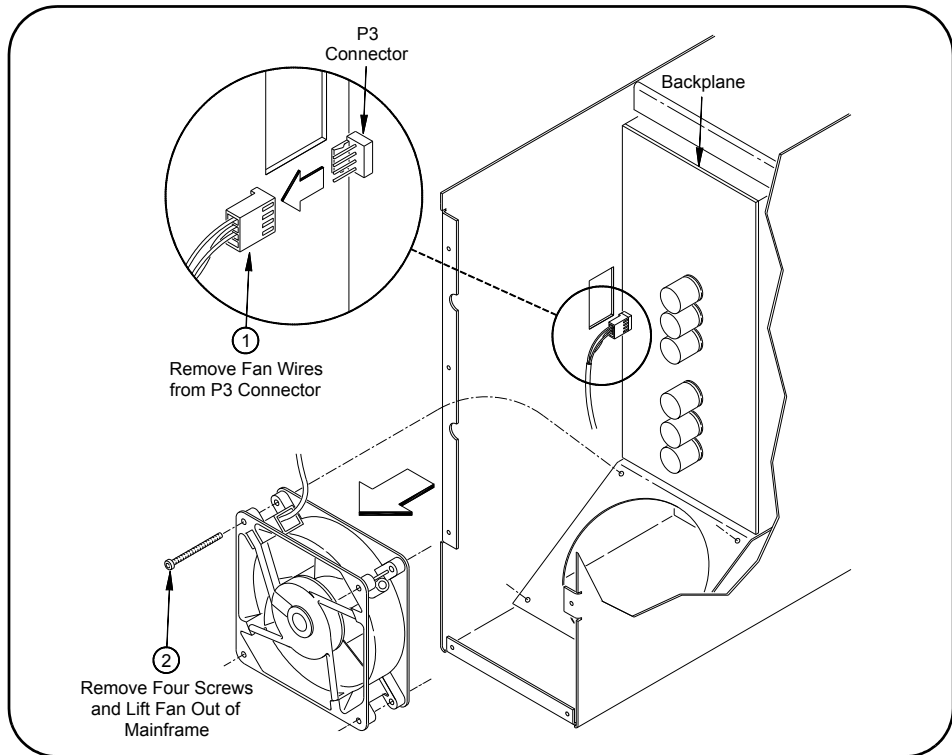

**Figure 3-5. Removing the Fan Assembly**

## Replacing the Front Panel Tapped Strip

This section gives guidelines to replace the Front Panel Tapped Strip. See Table 3-1 for a replacement part number.

- 1 Turn off the mainframe and remove the AC power cord.
- 2 If the mainframe is rack-mounted, remove the mainframe from the rack and place the mainframe at a static-controlled workstation.
- 3 Remove mainframe accessory items as required. See "Removing Mainframe Accessory Items".
- 4 Remove the mainframe cover. See "Removing the Mainframe Cover".
- 5 Remove the Front Panel Tapped Strip as shown in Figure 3-6.
- 6 Install the replacement Front Panel Tapped Strip by reversing the steps in Figure 3-6.
- 7 Replace the mainframe cover by reversing the steps in "Removing the Mainframe Cover".
- 8 Reinstall mainframe accessory items removed in step 3 OR reinstall the mainframe in the rack (as required). Reconnect AC power cord.

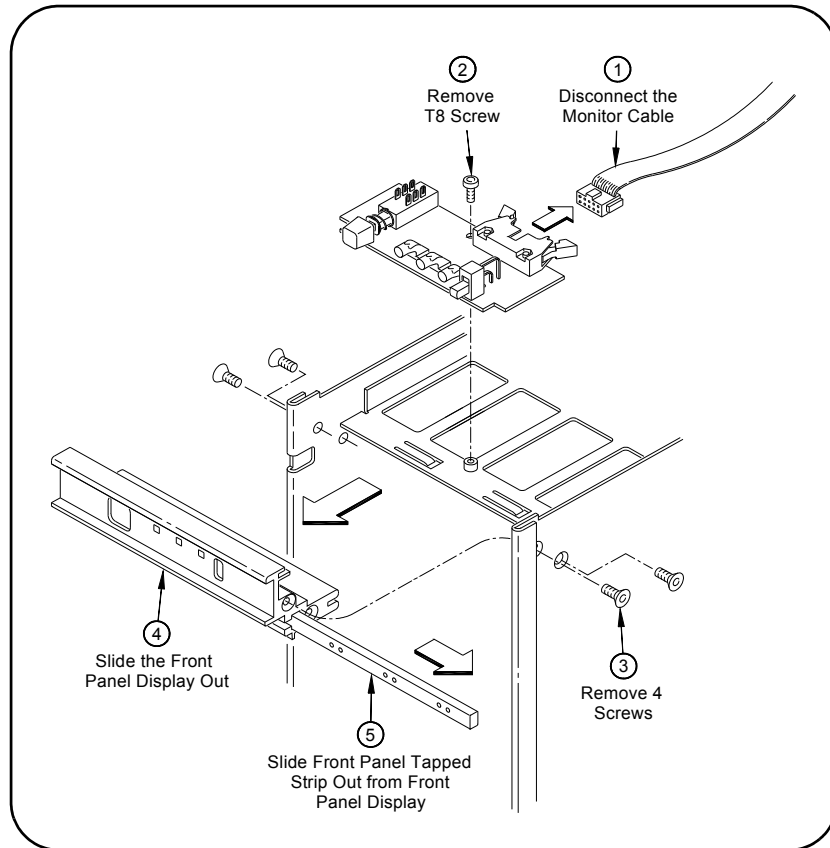

Figure 3-6. Removing the Front Panel Tapped Strip

## Replacement Power Cords

Table 3-3 lists the power cords rated for use with the E8408A mainframe. If it is necessary to replace the power cord, obtain the appropriate cord listed in the table or use a cord with the same voltage and current ratings.

**Table 3-3. Replacement Power Cords for E8408A VXI Mainframe**

Country	Voltage	Part Number	Rated Amps
U.K.	250 VAC	8120-1351	10A
Australia	250 VAC	8120-1369	10A
Europe	250 VAC	8120-1689	10A
U.S./Canada	125 VAC	8120-1378	10A
U.S./Canada	250 VAC	8120-5338	10A
Switzerland	250 VAC	8120-2104	10A
Denmark	250 VAC	8120-2956	10A
Japan	100 VAC	8120-4753	12A
India / South Africa	250 VAC	8120-4211	10A

Power cords supplied by Agilent have polarities matched to the power input socket on the instrument:

- L = line or active conductor (also called "live" or "hot")
- N = neutral or identified conductor
- E = earth or safety ground

## Cleaning Instructions

The only cleaning required for the E8408A mainframe is to wipe the exterior of the mainframe with a clean, damp cloth and dry with a clean, dry cloth. Do not attempt to clean any interior parts of the mainframe.



**Notes:**

---

# Appendix A

## E8408A Product Specifications

### Product Description

This section describes the E8408A mainframe, including:

- Product Dimensions
- Options and Accessories
- General VXI Specifications
- Mainframe Monitor Specifications
- Backplane Specifications

### Product Dimensions

Figure A-1 shows E8408A dimensions. Empty mainframe weight is 8.6 Kg (19 lb.) without protective bumpers and 9.1 Kg (20 lb.) with bumpers. Weight with four average VXI modules installed is 15.9 Kg (35 lb.). Maximum module weight is 3.5 Kg (7.7 lbs) per slot to comply with shock and vibration specifications. Heavier modules may be installed if the shock and vibration environment is less severe.

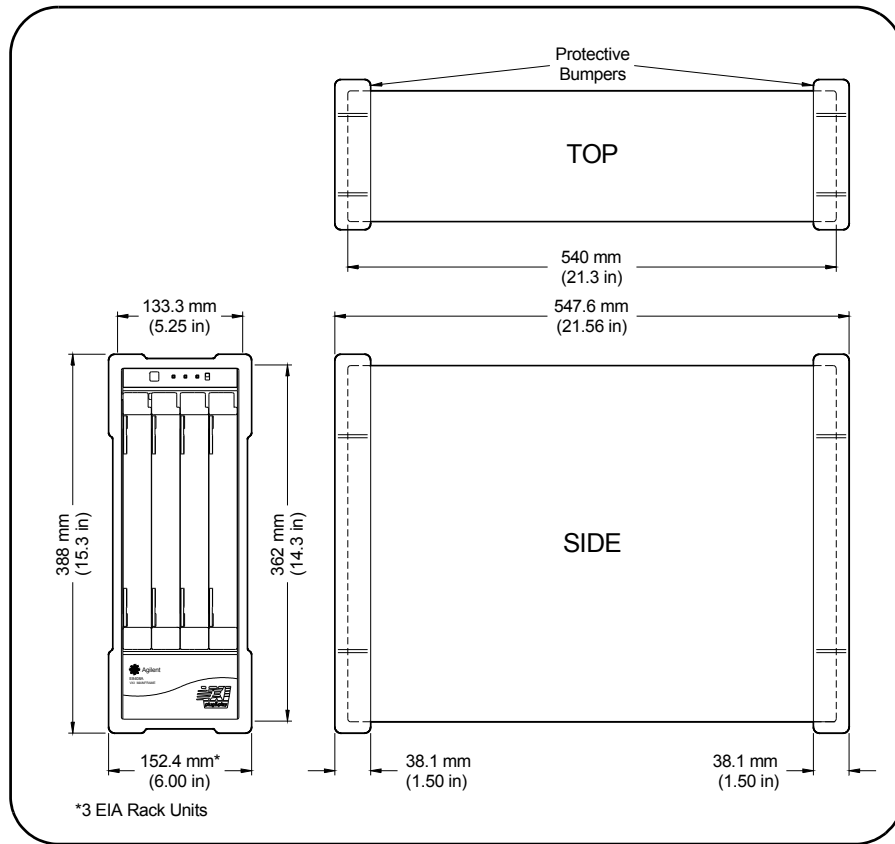

Figure A-1. E8408A Mainframe Dimensions

## Options and Accessories

Description	Product Number
<b>Standard Configuration</b>	
4-Slot, C-Size 175 W VXI Mainframe (includes front panel indicators, protective bumpers, and carrying handle)	E8408A
VXI Instruments (Modules) Installed with Standard Settings	E8404A Option 500
Installed Backplane Connector Shields	E8408A Option 918
Standard Configuration, except Add Additional Current from -5.2V Source	E8408A Option 001
(Remanufactured) Power Supply Assembly (Standard)	E8408-69005
(Remanufactured) Power Supply Assembly (Option 001)	E8408-69006
Airflow Restrictor (1-slot)	E8400-80917
Replacement Fan Assembly	E8408-68500
Intermodule Chassis Shield Kit	E8400-80919
EMC Filler Panel (1-slot)	E8400-60202
VXI Slot Filler Panel (1-slot)	E8400-44305
E8408A User/Service Manual (if ordered separately)	E8408-90001
Convert 3 year return-to-to 1 year On-Site Warranty	E8408A Option W01
<b>Portable Configuration</b>	
Carrying Strap and Accessory Pouch	E8396A
<b>Rack Mount Configuration</b>	
Rack Mount/Cable Route Adapter Kit. Must also use either E3663A Support Rail Kit or 1494-0413 Rack Slide Kit	E8397A
Field Installation Kit for Rack Mount/Cable Route Adapter Kit	E8408-80923
Support Rail Kit. Used with E8397A.	E3663A
Rack Slides to mount in rack cabinet. Used with E8397A.	1494-0413*

\* For non-Agilent cabinets, must also use 1494-0061 End Brackets

## General VXI Specifications

Category	Specifications
VXI Device Type:	Mainframe
Data Transfer Bus:	All per VXIbus Specification, Rev 1.4
Size:	C-Size
Slots:	4 available
Connectors:	P1/P2
Shared Memory:	n/a
VXI Buses:	per VXIbus Spec, Rev 1.4

## Monitor Specifications

Interface	Description																
Power Switch	<b>Stdby</b> - AC power is applied to the mainframe, but not to installed VXI instruments. <b>On</b> - AC power applied to the mainframe, and DC to installed VXI instruments.																
Voltages Indicator	<b>Green</b> - all voltages on the VXI backplane are present. (Does not necessarily indicate that voltages are within the VXI specification.) <b>Flashing Amber</b> - one or more voltages is missing or incorrect. The backplane voltages and allowed variations are listed below:  <table border="0" style="margin-left: 40px;"> <thead> <tr> <th style="text-align: left;"><u>Voltage</u></th> <th style="text-align: left;"><u>Allowed Variation</u></th> </tr> </thead> <tbody> <tr> <td>+5V</td> <td>+4.875V to +5.125V</td> </tr> <tr> <td>+12V</td> <td>+11.64V to +12.6V</td> </tr> <tr> <td>-12V</td> <td>-12.6V to -11.64V</td> </tr> <tr> <td>+24V</td> <td>+23.28V to +25.2V</td> </tr> <tr> <td>-24V</td> <td>-25.2V to -23.28V</td> </tr> <tr> <td>-5.2V</td> <td>-5.46V to -5.044V</td> </tr> <tr> <td>-2V</td> <td>-2.1V to -1.9V</td> </tr> </tbody> </table>	<u>Voltage</u>	<u>Allowed Variation</u>	+5V	+4.875V to +5.125V	+12V	+11.64V to +12.6V	-12V	-12.6V to -11.64V	+24V	+23.28V to +25.2V	-24V	-25.2V to -23.28V	-5.2V	-5.46V to -5.044V	-2V	-2.1V to -1.9V
<u>Voltage</u>	<u>Allowed Variation</u>																
+5V	+4.875V to +5.125V																
+12V	+11.64V to +12.6V																
-12V	-12.6V to -11.64V																
+24V	+23.28V to +25.2V																
-24V	-25.2V to -23.28V																
-5.2V	-5.46V to -5.044V																
-2V	-2.1V to -1.9V																
Temp Indicator	<b>Green</b> - the power supply temperature is acceptable. <b>Flashing Amber</b> - the power supply is approaching thermal shutdown.																
Fan Indicator	<b>Green</b> - mainframe cooling fan is operating properly. <b>Flashing Amber</b> - mainframe cooling fan is not operating.																
Fan Speed Switch	<b>Full</b> - the mainframe cooling fan is operating at full speed. <b>Var(iable)</b> - the mainframe cooling fan is providing adequate cooling (default setting).																

## Backplane Specifications

- Automatic daisy-chain jumpering for BUS GRANT and IACK signals.
- Full differential distribution of CLK10.
- ACFAIL\* and SYSRESET\* in full compliance with the VMEbus and VXIbus Specifications.
- Surface mount construction and no sockets for maximum reliability.

# Power Specifications

This section describes E8408A mainframe power specifications for the Standard and Option 001 configurations. The total power delivered from the Option 001 configuration cannot exceed the total power delivered from the Standard configuration.

## Total Usable Power

Temperature	Usable Power (90-264 Vac) <sup>1</sup>
0 - 40°C	175 W
40 - 50°C	150 W
50 - 55°C	125 W

<sup>1</sup> Total output before thermal shutdown or safety limitation.

## Peak and Dynamic Current

Voltage	Peak Current I <sub>MP</sub> (Amps) <sup>1,2</sup>		Dynamic Current I <sub>MD</sub> (Amps) <sup>1,3</sup>	
	Standard	Option 001	Standard	Option 001
+5V <sup>4,5</sup>	17A	19.4A	2.5A	2.5A
+12V <sup>7</sup>	2.7A	2.7A	1.0A	1.0A
- 12V <sup>7</sup>	2A	2A	0.8A	0.8A
+24V	2A	2A	1.0A	1.0A
- 24V <sup>6</sup>	2A	0.5A	1.0A	0.25A
-5.2V <sup>5</sup>	2A	5.8A	1.0A	1.0A
- 2V	2A	2A	1.0A	1.0A

<sup>1</sup> Specifications apply at the mainframe backplane, 0 - 55°C.

<sup>2</sup> I<sub>MP</sub> = Rated mainframe peak DC output current as defined by the VXIbus Specification.

<sup>3</sup> I<sub>MD</sub> = Rated mainframe peak-to-peak dynamic current as defined in the VXIbus Specification by a current vs. frequency curve.

<sup>4</sup> +5V must have 1.0A minimum load for other supplies to be in regulation specification.

<sup>5</sup> (Standard Only) Maximum +5V current can be increased if -5.2V load is less than 2.0A maximum  
Maximum = 17.0A + 1.2\*(2.0A - Load on -5.2V).

<sup>6</sup> (Option 001 Only) Maximum -24V current can be increased if -5.2V load is less than 5.8A maximum  
Maximum = 0.5A + 0.24\*(5.8A - Load on -5.2V).

<sup>7</sup> Maximum +12V current can be increased if -12V load is less than 2.0A maximum  
Maximum = 2.7A + 1.2\*(2.0A - Load on -12V)

## Output Voltage

Voltage	Allowed Variation*	Ripple/Noise DC Load*	Induced Ripple/Noise*
+5V	+0.25V / -0.125V	50mV	50mV
+12V	+0.60V / -0.36V	50mV	50mV
-12V	-0.60V / +0.36V	50mV	50mV
+24V	+1.20V / -0.72V	150mV	150mV
-24V	-1.20V / +0.72V	150mV	150mV
-5.2V	-0.26V / +0.156V	50mV	50mV
-2V	-0.10V / +0.10V	50mV	50mV

\* Specifications apply at the backplane, 0 - 55 °C.

## Power Input

Area	Specification	Comments
Input Voltage/ Frequency	90 Vac min - 140 Vac max (47 Hz min - 440 Hz max)  90 Vac min - 264 Vac max (47 Hz min - 66 Hz max)	
Input Voltage	90 Vac to 264 Vac CAT II 280 VA max	Automatic Ranging
Inrush Current	< 75A @ 264 Vac < 35A @ 132 Vac	Cold start
Power Switch	On/Standby	
Chassis Ground Tap	M4 x 0.7 threaded nut insert	On rear of mainframe

# Cooling Specifications

This section lists E8408A mainframe cooling specifications, including:

- Cooling Table
- Cooling Chart

## Cooling Table

Area	Specification/Comments
Cooling Modes	High or variable cooling mode switchable on the front panel. Same fan cools power supply and modules.
High-Speed Fan Mode	Maximum airflow all the time.
Variable Fan Speed Mode:	Fan speed changes between high and low as a function of ambient and power supply temperatures.
AirFlow Path	Air is routed into the mainframe rear and exhausted out the left side (viewed from the front) when the mainframe is in horizontal orientation. When the mainframe is rack-mounted, allow 50 mm of clearance at the rear and left side for proper airflow.
Acoustic Noise*	High Speed Fan Mode: <40 dBA. Variable Fan on Low Speed: <30 dBA.

\* Sound power at bystander position one meter in front of mainframe.

## Cooling Chart

Figure A-2 shows E8408A cooling specifications (for all E8408A slots) per VXI-8 Specification Draft 2.0 and Airflow Test Fixture revision 1.7 with:

- VXI-8 Standard Modules installed in other slots.
- Measurements taken at 1,500 m altitude.

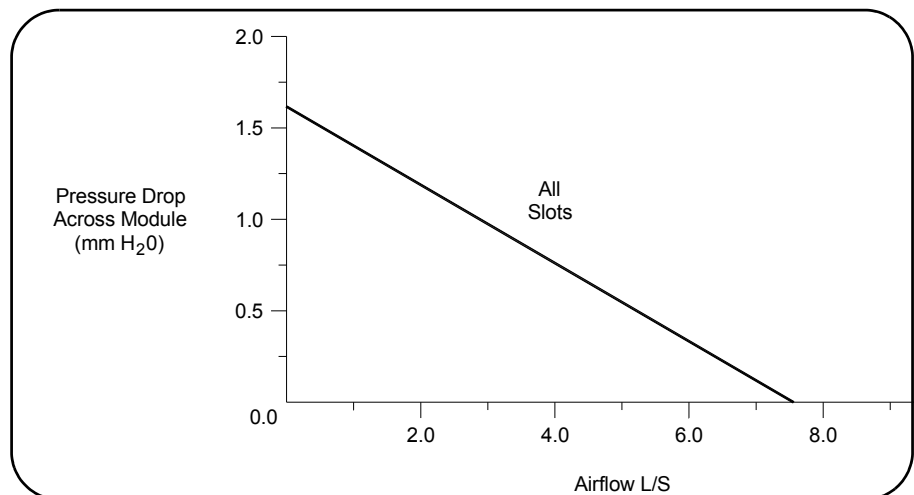

Figure A-2. E8408A Mainframe Cooling Capacity

# Safety/Environmental Specifications

This section describes safety and environmental specifications for the E8408A mainframe, including:

- Environmental Specifications
- Electromagnetic Compliance/Safety Specifications
- Power Supply Protection
- Repair

## Environmental Specifications

Area	Specification
Operating Location	Indoor: Sheltered location where air temperature and humidity is controlled within this product's specifications and the equipment is protected against direct exposure to climatic conditions such as direct sunlight, wind, rain, snow, sleet and icing, water spray or splash, hoarfrost, or dew (typically indoors). Pollution degree 2.
Temperature	Operating Temperature Range: 0°C to +55°C Storage Temperature Range: -40 °C to +70° C
Humidity (Non-condensing)	<u>Operating Humidity Range:</u> - Up to 95% RH from 0°C to +40 °C - Up to 65% RH from +40°C to +55°C  <u>Storage Humidity Range:</u> - Up to 95% RH from 0°C to +55°C - Up to 90% RH from +55 °C to +65°C
Shock	<u>End Use Handling:</u> Half sine waveform, <3 msec duration, $\Delta v = 160$ cm/sec minimum  <u>Transportation:</u> Trapezoidal waveform, $\Delta v = 605$ cm/sec, 30 g minimum
Vibration	<u>Operating and Functional:</u> 5 to 500 Hz, 0.0001 g <sup>2</sup> /Hz Spectral Density  <u>Survival. Swept Sine:</u> 5 to 500 Hz Resonance Search, 5 minute dwell on resonances at 0.5g  <u>Survival. Random:</u> 0.015 g <sup>2</sup> /Hz Spectral Density
Altitude	Up to 3,000 m



## Electromagnetic Compliance/Safety Specifications

The E8408A mainframe conforms to the EMC and safety product specifications listed in the Declaration of Conformity (see Page 7). EMC performance can be further enhanced with the following shields:

- Front panel gasketing provided per VXI Rev. 2.0, B.7.2.3
- Backplane connector shields per VXI Rev 2.0, B.7.2.3
- Intermodule chassis shields per VXI Rev 2.0, B.7.3.4

## Power Supply Protection

The supply is protected from over-temperature, over-voltage, short-to-ground, and short-to-other output. Protection modes vary, from removing the fault condition to cycling the power on/standby switch to removing and reconnecting AC power.

## Over-Temperature Protection

The front panel **Temp** (temperature) indicator flashes when an internal temperature is high enough to cause the mainframe to approach thermal shutdown, but the **Temp** indicator does not cause shutdown. When thermal shutdown limit is reached, all supplies are automatically turned off. Recovery occurs automatically when the mainframe has cooled sufficiently.

## Over-Voltage Protection

Over-voltage will generally cause a global shutdown, and recovery occurs when the **Power On/Standby** switch is cycled. However, some over-voltage conditions on the +5V and +12V can cause a shutdown that will not respond by cycling the **Power On/Standby** switch. In this case, the **Power On/Standby** switch should be placed in Standby position and AC power must be removed and reapplied before the mainframe will turn on again.

## Short-to-Ground Protection

Short circuit behavior varies with the specific supply, but (in general) recovery should occur when the short is removed. This table summarizes short-circuit behavior for each supply voltage.

Supply Shorted	Short-Circuit Behavior
+5V or +12V	Causes global shutdown. After about 250 msec, the supplies will automatically attempt to turn on. Global shutdown and restart attempts will continue until the fault is removed.
+24V	Puts supply in foldback current limiting mode.
-24V	Puts supply in foldback current limiting mode, and shuts down the -12V, -5.2V, and -2V supplies.
-12V	Continuously draws about 7 Amps and shuts down the -5.2V and -2V supplies.
-5.2V	Continuously draws about 7 Amps (Standard).
-5.2V	Continuously draws about 12 Amps (Option 001).
-2V	Continuously draws about 5 Amps.

## Short-to-Other Protection

A short-to-other output will generally cause a global shutdown. When the fault is removed, the supplies will typically recover when the **Power On/Standby** switch is cycled. However, if this switch is cycled while the fault is still present, some supplies may become active or global shutdown may occur again.

Conditions such as +5V-to-other output and -12V-to-(-5.2V) may cause a shutdown that will not respond to cycling the **Power On/Standby** switch. In this case, the **Power On/Standby** switch should be placed in Standby position and AC power must be removed and reapplied before the mainframe will turn on again.

## Repair

Diagnosis and troubleshooting through the front panel monitor (*MTTR = Mean Time to Repair*).

Item	Time
MTTR, power supply assembly:	< 20 min (w/mainframe and modules fully installed in rack)
MTTR, fan:	< 30 min (w/mainframe and modules fully installed in rack)

**Notes:**

---

**A**

AC power requirements, 11  
airflow restricter kit, installing, 44

**B**

backplane connector shields, installing, 43

**C**

component failures, 48  
cooling chart, 62  
cooling specifications, 62  
cooling table, 62  
cooling, mainframe, 11

**D**

display, front panel, 16  
documentation history, 6

**E**

electromagnetic compliance specifications, 63–64  
environmental specifications, 63

**F**

fan, replacing, 53  
front panel features, 16  
front panel tapped strip, replacing, 54

**I**

installing VXI instruments, 13  
  A- and B-size, 15  
  C-size, 14

**L**

locating mainframe problems, 48

**M**

mainframe  
  cooling, 11  
  portable configuration, 19  
  rack mounting using rack slide kit, 21  
  rack mounting using support rail kit, 32

mainframe components, replacing, 48  
monitor board, replacing, 52

**O**

options and accessories, 58

**P**

parts list, replaceable, 47  
peak and dynamic current, 60  
portable configuration, mainframe, 19  
positioning mainframe for cooling, 11  
power cords, replacement, 55  
power input, 61  
power requirements, 11  
power specifications, 60  
power supply  
  cooling, 11  
  protection, 64  
power supply assembly, removing, 51  
problem isolation, 48  
product description, 57–58  
product dimensions, 57  
product overview, 9

**R**

rack mounting  
  using rack slide kit, 21  
  using support rail kit, 32  
removing mainframe cover, 50  
removing the power supply assembly, 51  
repair, 65  
repair, mainframe, 48  
replaceable parts list, 47  
replacement power cords, 55  
replacing components  
  removing mainframe cover, 50  
  removing mainframe items, 49  
  removing power supply assembly, 51  
  replacement power cords, 55  
  replacing fan, 53  
  replacing front panel tapped strip, 54  
  replacing monitor board, 52  
replacing mainframe components, 48  
replacing the fan, 53

replacing the front panel tapped strip, 54  
replacing the monitor board, 52  
restricted rights statement, 5

## **S**

safety symbols, 6  
safety/environmental specifications, 63  
specifications  
    backplane specifications, 59  
    cooling, 62  
    cooling chart, 62  
    cooling table, 62  
    dynamic and peak current, 60  
    electromagnetic compliance, 63–64  
    environmental, 63  
    front panel monitor, 59  
    general, 59  
    mainframe, 57  
    options and accessories, 58  
    output voltage, 61  
    peak and dynamic current, 60  
    power, 60  
    power input, 61  
    power supply protection, 64  
    product description, 57–58  
    product dimensions, 57–58  
    repair, 65  
    safety, 63  
    total usable power, 60

## **T**

total usable power, 60  
trademark information, 5

## **V**

VXI instruments, installing, 13

## **W**

WARNINGS, 6, 47  
warranty statement, 5