

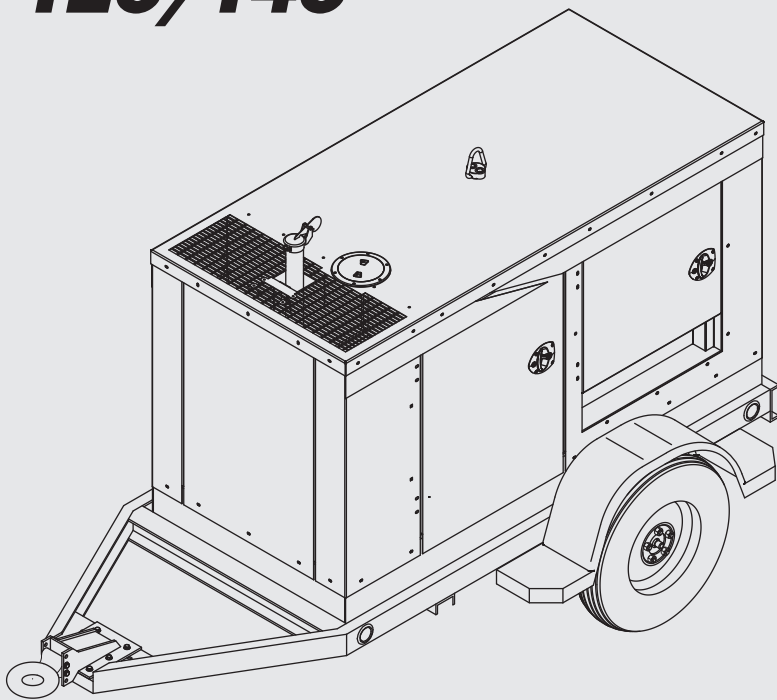

TEREX[®]

Service Manual

T25/T45



First Edition

Rev A

Part No. 134878

August 2008

Introduction

Important

Read, understand and obey the safety rules and operating instructions in the appropriate Operator's Manual on your machine before attempting any maintenance procedure.

Basic mechanical, hydraulic and electrical skills are required to perform most procedures. However, several procedures require specialized skills, tools, lifting equipment and a suitable workshop. In these instances, we strongly recommend that maintenance and repair be performed at an authorized TEREX dealer service center.

Technical Publications

TEREX Corporation has endeavored to deliver the highest degree of accuracy possible. However, continuous improvement of our products is a TEREX policy. Therefore, product specifications are subject to change without notice.

Readers are encouraged to notify TEREX of errors and send in suggestions for improvement. All communications will be carefully considered for future printings of this and all other manuals.

Contact Us:

www.TEREX.com

Serial Number Information

TEREX Corporation offers the following manuals for these models:

Title	Part No.
TEREX T25I & T45I Operator's Manual, First Edition	133255
TEREX T25I & T45I Parts Manual, First Edition	134877
Newage Generator Manual	836430
Isuzu Engine Manual	116133
Cascade Controller Manual	833011
Dexter Axle Manual	833014

Copyright © 2008 by TEREX Corporation

134878 Rev A August 2008
First Edition, First Printing

"TEREX" is a registered trademark of TEREX Corporation in the USA and many other countries. "Super Quiet" is a trademark of TEREX Corporation.

 Printed on recycled paper

Printed in U.S.A.

How to Read Your Serial Number

Serial Number Legend

The serial number plate on your T25I & T45I Super Quiet Generator is located on the twist lock area of the lower control panel.

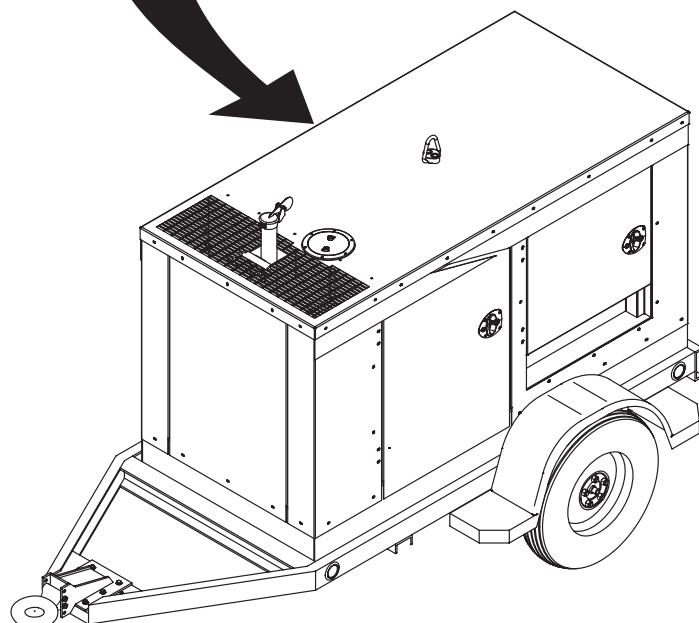
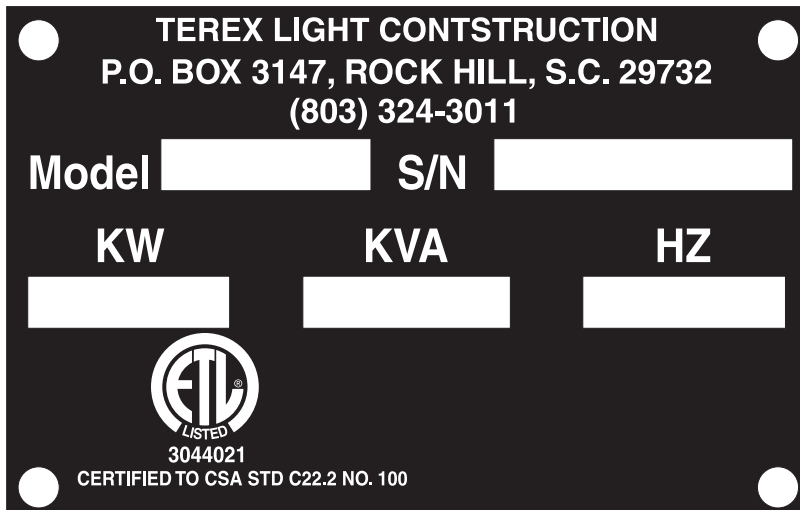

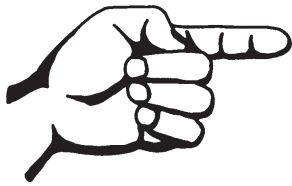

This page intentionally left blank.



Danger

Failure to obey the instructions and safety rules in this manual and the appropriate Operator's Manual on your machine will result in death or serious injury.

Many of the hazards identified in the operator's manual are also safety hazards when maintenance and repair procedures are performed.

Do Not Perform Maintenance Unless:

- You are trained and qualified to perform maintenance on this machine.
- You read, understand and obey:
 - manufacturer's instructions and safety rules
 - employer's safety rules and worksite regulations
 - applicable governmental regulations
- You have the appropriate tools, lifting equipment and a suitable workshop.

SAFETY RULES

Personal Safety

Any person working on or around a machine must be aware of all known safety hazards. Personal safety and the continued safe operation of the machine should be your top priority.



Read each procedure thoroughly. This manual and the decals on the machine, use signal words to identify the following:



Safety alert symbol—used to alert personnel to potential personal injury hazards. Obey all safety messages that follow this symbol to avoid possible injury or death.



Indicates an imminently hazardous situation which, if not avoided, will result in death or serious injury.



Indicates a potentially hazardous situation which, if not avoided, could result in death or serious injury.



Indicates a potentially hazardous situation which, if not avoided, may cause minor or moderate injury.



Indicates a potentially hazardous situation which, if not avoided, may result in property damage.



Be sure to wear protective eye wear and other protective clothing if the situation warrants it.



Be aware of potential crushing hazards such as moving parts, free swinging or unsecured components when lifting or placing loads. Always wear approved steel-toed shoes.

Workplace Safety



Be sure to keep sparks, flames and lighted tobacco away from flammable and combustible materials like battery gases and engine fuels. Always have an approved fire extinguisher within easy reach.



Be sure that all tools and working areas are properly maintained and ready for use. Keep work surfaces clean and free of debris that could get into machine components and cause damage.



Be sure any forklift, overhead crane or other lifting or supporting device is fully capable of supporting and stabilizing the weight to be lifted. Use only chains or straps that are in good condition and of ample capacity.



Be sure that fasteners intended for one time use (i.e., cotter pins and self-locking nuts) are not reused. These components may fail if they are used a second time.



Be sure to properly dispose of old oil or other fluids. Use an approved container. Please be environmentally safe.



Be sure that your workshop or work area is properly ventilated and well lit.



Table of Contents

Introduction

Important Information - Introduction	<i>ii</i>
How to Read Your Serial Number	<i>iii</i>
Parts Stocking List	<i>ix</i>
How to Order Parts	<i>xi</i>
Service Parts Fax Order Form	<i>xii</i>

Section 1**Safety Rules**

General Safety Rules	<i>v</i>
----------------------------	----------

Section 2**Rev****Specifications**

A	Specifications	2 - 1
A	Specifications (Continued)	2 - 2
A	Torque Specifications	2 - 3
A	Generator Torque Specifications	2 - 4

Section 3**Rev****Scheduled Maintenance Procedures**

	Introduction	3 - 1
	Pre-delivery Preparation Report	3 - 2
A	Maintenance Schedules	
	Isuzu Lubrication and Maintenance Service Intervals	3 - 3
	Newage Generators Maintenance Schedule	3 - 4

Section 4**Rev****Troubleshooting**

	Introduction	4 - 1
A	Troubleshooting Guide	4 - 2

TABLE OF CONTENTS

Section 5	Rev	Schematics	
	A	Introduction	5 - 1
	A	Electrical Schematic - Control Panel Wiring for Murphy Cascade Controller	5 - 2
	A	Electrical Schematic - Control Panel Wiring for Murphy Cascade Controller w/Electronic Governor	5 - 3
	A	Electrical Schematic - Distribution Panel Wiring	5 - 4
	A	Electrical Schematic - Three Position Stack Switch Wiring	5 - 5
	A	Electrical Schematic- Overcurrent Relay	5 - 6
	A	Electrical Schematic - Generator Wiring Breakdown	5 - 7
	A	Electrical Schematic - Standard Generator Wiring	5 - 8



Parts Stocking List

Required Parts

The following parts are required to perform maintenance procedures as outlined in the *TEREX T25I & T45I Parts and Service Manual*.

Description	Part No.
Isuzu Models	
Oil Filter	868075
Air Filter	834460
Fuel Filter	868137
Belt	868067

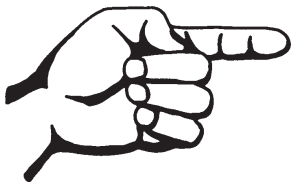

This page intentionally left blank.



How To Order Parts

Please be prepared with the following information when ordering replacement parts for your TEREX product:

- Machine model number
- Machine serial number
- Terex part number
- Part description and quantity
- Purchase order number
- "Ship to" address
- Desired method of shipment
- Name and telephone number of the authorized TEREX Distributor in your area

TEREX North America

Telephone (803) 324-3011

Toll Free (800) 433-3026 in U.S.A. and Canada

Fax (803) 366-1101

Use the Service Parts Fax Order Form on the next page and fax your order to our Parts Department.

If you don't know the name of your authorized distributor, or if your area is not currently serviced by an authorized distributor, please call TEREX Corporation.

Machine Information

Model

Serial Number

Date of Purchase

Authorized TEREX Distributor

Phone Number



August 2008

Service Parts fax Order Form

FAX TO: (800) 633-5534 OR TOLL FREE: 800-433-3026

Please fill out completely

Date _____ Account Number _____

Your Name _____ **Your Fax Number** _____

_____ Your Phone Number _____

Bill To _____ Ship To _____

Purchase Order Number _____ Ship Via _____

Model(s) _____ **Serial No.(s)** _____

Optional Equipment _____

Part Number	Description	Quantity	Price

All backordered parts will be shipped when available via the same ship method as the original order unless noted below:

- Ship complete order only - no backorders
- Ship all available parts and contact customer on disposition of backordered parts
- Other (please specify)

FOR TEREX USE ONLY

Order Number _____ Origin Code _____ Comments _____

Date Scheduled _____ Ship Condition _____

Order Total _____ Terms Code _____

remove this page and make copies

remove this page and make copies



Specifications

REV A

MODEL		T25I	T45I
POWER CAPABILITY-PRIME			
kVA (kilovolt-amperes)		25	45
kW		20	36
3 Phase Amp Ratings			
	208V	69	125
	240V	60	108
	480V	30	54
POWER CAPABILITY-STANDBY			
kVA (kilovolt-amperes)		30	50
kW (kilowatts)		24	40
3 Phase Amp Ratings			
	208V	83	139
	240V	72	120
	480V	36	60
VOLTAGE			
3 Phase 208, 220, 240, 416, 440, 480		Standard	Standard
600 Volt		Optional	Optional
1 Phase 120, 127, 139, 240, 254, 277		Standard	Standard
Max Motor Starting ¹	Hp	12	27
	kW	9	20
SKVA		70	165
DIESEL ENGINE			
Manufacturer		Isuzu	Isuzu
Model		4LE1PV02	4JG1TPV
Cylinder		4	4
Air Intake (aspiration)		Natural	Turbo
Cooling System		Std Rad	Std Rad
Fuel Capacity (gal)		64	64
Run Time (75% load)		53	29
Fuel Consumption, Prime Power (gal per hr)	100% load	1.5	2.8
	75% load	1.1	2.2
	50% load	0.8	1.7
	25% load	0.4	1.2
dBA		64	64
Controller Type		Analog/Digital	Analog/Digital
Start/Stop Controller		Cascade	Cascade
12V Battery (CCA)		750	750



SPECIFICATIONS

REV A

MODEL		T25I	T45I
GENERATOR			
Brushless, 4 pole, Synchronous, Single-bearing		Standard	Standard
1,800 rpm, Class H Insulation Generator		Standard	Standard
High wye, Low wye, Zig-zag Voltage Selector		Standard	Standard
3 Phase Voltage: 208, 220, 240,416, 440, 480		Standard	Standard
600 Volt		Optional	Optional
1Phase Voltage: 120, 127, 139, 240, 254, 277		Standard	Standard
Convenience Receptacles:		Standard	Standard
2 - 20A GFCI Duplex Receptacles		Standard	Standard
2 - 50A Tempowers		Standard	Standard
AVR Voltage Regulation		Standard	Standard
Mechanical Standard (5%) Speed Control (governor)		Standard	Standard
Murphy Cascade Start/Stop Controller on All Engines		Standard	Standard
TRAILER			
No Brakes		Standard	Standard
Hydraulic Brakes		Optional	Optional
Electric Brakes		Optional	Optional
Pintle Rng, 3 inch		Standard	Standard
Coupler Hitch, 2 inch		Optional	Optional
Coupler Hitch, 2 5/16 inch		Optional	Optional
1 Maximum motor size is based on 35% voltage dip at 480V AC 3 phase 60Hz with a code G motor			
SKID MOUNT			
DIM (L x W x H - in)		84x39x51	84x39x51
Weight Dry (lbs)		1,900	2,725
Weight Full (lbs)		2,354	3,173
TRAILER MOUNT			
Dim (L x W x H)		137x66x68	137x66x68
Weight Dry (lbs)		2,375	3,200
Weight Full (lbs)		2,829	3,648



SAE FASTENER TORQUE CHART											
• This chart is to be used as a guide only unless noted elsewhere in this manual •											
SIZE	THREAD	Grade 5				Grade 8				A574 High Strength Black Oxide Bolts	
		LUBED		DRY		LUBED		DRY		LUBED	
		in-lbs	Nm	in-lbs	Nm	in-lbs	Nm	in-lbs	Nm	in-lbs	Nm
1/4	20	100	11.3	80	9	140	15.8	110	12.4	130	14.7
	28	90	10.1	120	13.5	120	13.5	160	18	140	15.8
		LUBED		DRY		LUBED		DRY		LUBED	
		ft-lbs	Nm	ft-lbs	Nm	ft-lbs	Nm	ft-lbs	Nm	ft-lbs	Nm
5/16	18	13	17.6	17	23	18	24	25	33.9	21	28.4
	24	14	19	19	25.7	20	27.1	27	36.6	24	32.5
3/8	16	23	31.2	31	42	33	44.7	44	59.6	38	51.5
	24	26	35.2	35	47.4	37	50.1	49	66.4	43	58.3
7/16	14	37	50.1	49	66.4	50	67.8	70	94.7	61	82.7
	20	41	55.5	55	74.5	60	81.3	80	108.4	68	92.1
1/2	13	57	77.3	75	101.6	80	108.4	110	149	93	126
	20	64	86.7	85	115	90	122	120	162	105	142
9/16	12	80	108.4	110	149	120	162	150	203	130	176
	18	90	122	120	162	130	176	170	230	140	189
5/8	11	110	149	150	203	160	217	210	284	180	244
	18	130	176	170	230	180	244	240	325	200	271
3/4	10	200	271	270	366	280	379	380	515	320	433
	16	220	298	300	406	310	420	420	569	350	474
7/8	9	320	433	430	583	450	610	610	827	510	691
	14	350	474	470	637	500	678	670	908	560	759
1	8	480	650	640	867	680	922	910	1233	770	1044
	12	530	718	710	962	750	1016	990	1342	840	1139
1.125	7	590	800	790	1071	970	1315	1290	1749	1090	1477
	12	670	908	890	1206	1080	1464	1440	1952	1220	1654
1.25	7	840	1138	1120	1518	1360	1844	1820	2467	1530	2074
	12	930	1260	1240	1681	1510	2047	2010	2725	1700	2304
1.5	6	1460	1979	1950	2643	2370	3213	3160	4284	2670	3620
	12	1640	2223	2190	2969	2670	3620	3560	4826	3000	4067

METRIC FASTENER TORQUE CHART																
• This chart is to be used as a guide only unless noted elsewhere in this manual •																
Size (mm)	Class 4.6				Class 8.8				Class 10.9				Class 12.9			
	LUBED		DRY		LUBED		DRY		LUBED		DRY		LUBED		DRY	
	in-lbs	Nm	in-lbs	Nm	in-lbs	Nm	in-lbs	Nm	in-lbs	Nm	in-lbs	Nm	in-lbs	Nm	in-lbs	Nm
5	16	1.8	21	2.4	41	4.63	54	6.18	58	6.63	78	8.84	68	7.75	91	10.3
6	19	3.05	36	4.07	69	7.87	93	10.5	100	11.3	132	15	116	13.2	155	17.6
7	45	5.12	60	6.83	116	13.2	155	17.6	167	18.9	223	25.2	1.95	22.1	260	29.4
	LUBED		DRY		LUBED		DRY		LUBED		DRY		LUBED		DRY	
	ft-lbs	Nm	ft-lbs	Nm	ft-lbs	Nm	ft-lbs	Nm	ft-lbs	Nm	ft-lbs	Nm	ft-lbs	Nm	ft-lbs	Nm
8	5.4	7.41	7.2	9.88	14	19.1	18.8	25.5	20.1	27.3	26.9	36.5	23.6	32	31.4	42.6
10	10.8	14.7	14.4	19.6	27.9	37.8	37.2	50.5	39.9	54.1	53.2	72.2	46.7	63.3	62.3	84.4
12	18.9	25.6	25.1	34.1	48.6	66	64.9	88	69.7	94.5	92.2	125	81	110	108	147
14	30.1	40.8	40	54.3	77.4	105	103	140	110	150	147	200	129	175	172	234
16	46.9	63.6	62.5	84.8	125	170	166	226	173	235	230	313	202	274	269	365
18	64.5	87.5	86.2	117	171	233	229	311	238	323	317	430	278	377	371	503
20	91	124	121	165	243	330	325	441	337	458	450	610	394	535	525	713
22	124	169	166	225	331	450	442	600	458	622	612	830	536	727	715	970
24	157	214	210	285	420	570	562	762	583	791	778	1055	682	925	909	1233

GENERATOR TORQUE SPECIFICATIONS

Generator	FT*LB
Flex Plate to Flywheel	12-15
Generator Case to Bellhousing	60
1/2" Socket Head Cap Screws for Lifting Channel	126
1/2-13" Hex Head Screws for Lifting Channel	120
Genset Isolators	33



Scheduled Maintenance Procedures



Observe and Obey:

- ☑ Maintenance inspections shall be completed by a person trained and qualified on the maintenance of this machine.
- ☑ Scheduled maintenance inspections shall be completed as specified using the supplied *Lubrication and Maintenance Service Interval Charts* provided in this section.

⚠ WARNING Failure to perform each procedure as presented and scheduled could result in death, serious injury or substantial damage.

- ☑ Immediately tag and remove from service a damaged or malfunctioning machine.
- ☑ Repair any machine damage or malfunction before operating the machine.
- ☑ Keep records on all inspections for three years.
- ☑ Machines that have been out of service for a period longer than 3 months must complete the quarterly inspection.
- ☑ Unless otherwise specified, perform each maintenance procedure with the machine in the following configuration:
 - Machine parked on a firm, level surface
 - Toggle switch in the "OFF" position
 - Wheels chocked

About This Section

This section contains detailed procedures for each scheduled maintenance inspection.

Each procedure includes a description, safety warnings and step-by-step instructions.

Symbols Legend



Safety alert symbol—used to alert personnel to potential personal injury hazards. Obey all safety messages that follow this symbol to avoid possible injury or death.

⚠ DANGER

Used to indicate the presence of an imminently hazardous situation which, if not avoided, will result in death or serious injury.

⚠ WARNING

Used to indicate the presence of a potentially hazardous situation which, if not avoided, could result in death or serious injury.

⚠ CAUTION

Used to indicate the presence of a potentially hazardous situation which, if not avoided, may cause minor or moderate injury.

NOTICE

Used to indicate operation or maintenance information.

- ⦿ Indicates that a specific result is expected after performing a series of steps.
- ⊗ Indicates that an incorrect result has occurred after performing a series of steps.

Pre-Delivery Preparation

Fundamentals

It is the responsibility of the dealer to perform the Pre-delivery Preparation.

The Pre-delivery Preparation is performed prior to each delivery. The inspection is designed to discover if anything is apparently wrong with a machine before it is put into service.

A damaged or modified machine must never be used. If damage or any variation from factory delivered condition is discovered, the machine must be tagged and removed from service.

Repairs to the machine may only be made by a qualified service technician, according to the manufacturer's specifications.

Scheduled maintenance inspections shall be performed by qualified service technicians, according to the manufacturer's specifications and the requirements listed in the responsibilities manual.

Instructions

Use the operator's manual on your machine.

The Pre-delivery Preparation consists of completing the Pre-operation Inspection, the Maintenance items and the Function Tests.

Use this form to record the results. Place a check in the appropriate box after each part is completed. Follow the instructions in the operator's manual.

If any inspection receives an N, remove the machine from service, repair and re-inspect it. After repair, place a check in the R box.

Legend

Y = yes, completed

N = no, unable to complete

R = repaired

Comments

Pre-Delivery Preparation	Y	N	R
Pre-operation inspection completed			
Maintenance items completed			
Function tests completed			

Model

Serial number

Date

Machine owner

Inspected by (print)

Inspector signature

Inspector title

Inspector company



TEREX North America

P.O. BOX 3147

Rock Hill, SC 29732 USA

Toll Free (800) 433-3026 in U.S.A. and Canada

Copyright © 2006 by TEREX Corporation. TEREX® is a registered trademark of TEREX Corporation.

Rev B



Maintenance Schedules

REV A

Isuzu Lubrication and Maintenance Service Intervals

ITEM	Daily	First 50 Hours	Every 250 Hours	Every 500 Hours	Every 750 Hours	Every 1000 Hours	Every 1250 Hours	Every 1500 Hours
Oil level and oil fouling	•							
Oil leakage check	•							
Oil pressure warning lamp	•							
Fuel leakage check	•							
Draining water in fuel filter	•							
Coolant level and fouling check	•							
Coolant leakage check	•							
Radiator filler cap fitting condition	•							
Fan belt tension check (Replace if necessary)	•							
Coolant replacement	•							
Electrolyte level check	•							
Battery cleaning	•							
Battery charge condition	•							
Preheating condition check	•							
Engine starting conditions and noise conditions	•							
Exhaust smoke condition	•							
Engine oil replacement		•	•	•	•	•	•	•
Oil filter element replacement		•		•		•		•
Fuel filter element replacement				•		•		•
Injection nozzle check				•		•		•
Cooling system circuit cleaning						•		
Starter and alternator check and cleaning						•		
Cylinder compression pressure						•		
Valve clearance check						•		
Positive crankcase ventilation valve cleaning								•

*Refer to the manufacturers manuals for detailed maintenance intervals and instructions. If the information in the manufacturer's manual differs from that in this manual the manufacturer's manual should take precedence.

Newage Maintenance Service Intervals

ITEM	DAILY	250 Hours or 3 Months	1500 Hours or 12 Months	4500 Hours or 3 Years	15000 Hours or 19 Years
Visual inspection	•				
Visual inspection plus running audible check		•			
Measure stator winding insulation resistance and record			•		
Monitor bearing/s condition			•		
Remove terminal box lid and check connections			•		
Re-grease bearings				•	
Measure vibration levels					•
Replace bearing/s					•
Replace NDE o-ring					•
Inspect bearing housings					•
Inspect winding conditions					•
Inspect rotating diode assembly					•

*Refer to the manufacturers manuals for detailed maintenance intervals and instructions. If the information in the manufacturer's manual differs from that in this manual the manufacturer's manual should take precedence.



Troubleshooting



Observe and Obey:

- ☑ Troubleshooting and repair procedures shall be completed by a person trained and qualified on the repair of this machine.
- ☑ Immediately tag and remove from service a damaged or malfunctioning machine.
- ☑ Repair any machine damage or malfunction before operating the machine.
- ☑ Unless otherwise specified, perform each repair procedure with the machine in the following configuration:
 - Machine parked on a firm, level surface.
 - Wheels chocked.
 - Toggle switch in "OFF" position.

Before Troubleshooting:

- ☑ Read, understand and obey the safety rules and operating instructions in the appropriate operator's manual on your machine.
- ☑ Be sure that all necessary tools and test equipment are available and ready for use.
- ☑ Be aware of the following hazards and follow generally accepted safe workshop practices.

⚠ DANGER Electrocutation hazard. Exposure to electrically charged circuits could result in death or serious injury. Remove all rings, watches and other jewelry.

⚠ DANGER Electrocutation hazard. Attempting to service the machine before the capacitors are fully discharged will result in death or serious injury.

⚠ DANGER High voltage. Exposure to electrical wires or electrical current will result in death or serious injury. Remove all rings, watches and other jewelry. Turn off all power when not needed for testing. Use extreme caution when working with high voltage electrical components.

⚠ CAUTION Burn hazard. Contact with hot engine components may cause severe burns. Use caution when working around a hot engine.

Troubleshooting Guide

The engine/generator set is tested and set at the factory for proper operation in the field. These units should never require additional adjustments in the field. If needed, adjustments should only be made by a qualified service technician, otherwise the manufacturer's warranty may become void.

<u>FAULT</u>	<u>POSSIBLE CAUSE</u>	<u>SOLUTION</u>
No generator output voltage	Circuit breaker tripped	Reset circuit breaker
	Voltage regulator	Check voltage regulator wiring
	Defective voltage regulator	Replace voltage regulator
	Defective Selector Switch	By pass by hardwiring generator
	Defective generator	Refer to generator manual
Low generator output voltage	Voltage adjustment set too low	Adjust voltage potentiometer
	Defective potentiometer	By pass or replace
	Low engine speed	Call TEREX Service
	Loose wire on voltage selector switch	Check wiring
	Fluctuating or surging engine speed	Check engine fuel, oil, and air filters
	Loose wire on voltage regulator sensing circuit	Check wiring
	Defective voltage regulator	Replace voltage regulator
High generator output voltage	Voltage adjustment potentiometer	Adjust potentiometer
	High engine speed	Call TEREX Service



TROUBLESHOOTING

<u>FAULT</u>	<u>POSSIBLE CAUSE</u>	<u>SOLUTION</u>
High generator output voltage	Defective automatic voltage regulator	Replace voltage regulator
	Loose wire on voltage adjustment potentiometer	Check wiring
	Neutral binding strap not in place.	Install neutral binding strap
Fluctuating generator output voltage	An "ON/OFF" type load may be the cause	Redistribute load if possible
	Fluctuating or surging engine speed	Check engine fuel, oil, and air filters
	Loose wiring in generator	Check connections
	Automatic voltage regulator stability setting may be wrong	Call TEREX Service
	Loose wire on the automatic voltage regulator sensing lead	Check wiring
Low engine speed	Engine speed adjustment has slipped	Call TEREX Service
	Clogged fuel system	Check for air leaks, clogged fuel filter, kinked fuel line, or clogged fuel pick-up tube
	Blocked air intake	Check air filter
	Blocked exhaust system	Check engine exhaust system, remove obstructions
	Contaminated fuel	Check fuel/water separator and fuel tank for contamination. Replace fuel if needed
	Defective governor on engine	Call TEREX Service

TROUBLESHOOTING

<u>FAULT</u>	<u>POSSIBLE CAUSE</u>	<u>SOLUTION</u>
Low Speed	Defective injectors on engine	Have injectors checked by a qualified technician
	"Surging" engine speed	Check engine fuel, oil, and air filters
Engine turns over (cranks), but won't run	Unit out of fuel	Check fuel level in tank, fill as needed
	Loose or broken wire in control circuit fuel injection pump solenoid	Check wiring to verify 12V DC is being supplied to the pump solenoid
	Defective solenoid	Replace solenoid
	Clogged fuel system	Check fuel system
	Air in fuel system	"Bleed" fuel system
	Defective fuel pump	Check and replace if defective
	Clogged air intake	Check air cleaner
	Clogged exhaust	Check exhaust system
	Contaminated fuel	Check fuel/water separator and tank for contamination
	Defective injectors	Have injection system checked by a trained technician
Lost engine compression	Have compression checked by a trained technician	
Engine won't crank	Loose battery cable or discharged battery	Check cables and battery electrolyte level. Recharge as necessary



TROUBLESHOOTING

<u>FAULT</u>	<u>POSSIBLE CAUSE</u>	<u>SOLUTION</u>
Engine won't crank	Engine "ON/OFF" switch set in "OFF" position	Check switch position
	Blown fuse in DC control circuit	Replace with 25 Amp. SLO-BLO TYPE fuse if needed.
	E-Stop	Check to see if engaged
	Defective starter solenoid	Replace solenoid
	Defective starter	Replace starter
	Seized engine	Have engine checked by a qualified technician
Engine runs, but loses speed	Unit is overloaded	Reduce load
	Improper connection	Check or Call TEREX Service
Engine runs, but loses power under load	Clogged fuel system	Check fuel system air in fuel lines
	Blocked air intake	Check air cleaner
	Blocked exhaust	Check exhaust system
	Contaminated fuel	Check fuel/water separator and fuel tank for contamination
	Faulty governor, defective injectors, or defective fuel pump	Have unit checked by a trained service technician for all of these items
Engine shuts down automatically and TROUBLE LIGHT on CONTROL PANEL is illuminated	Oil Pressure Switch	Not opening
	Improper coolant or water mixture	Use a 50/50 mix of water and anti-freeze only

TROUBLESHOOTING

<u>FAULT</u>	<u>POSSIBLE CAUSE</u>	<u>SOLUTION</u>
Engine shuts down automatically and TROUBLE LIGHT on CONTROL PANEL is illuminated	Overloaded engine	Reduce load
	Broken fan belt	Inspect fan belt and replace as needed
	Defective thermostat or thermocouple switch	Inspect thermostat switch
	Defective water pump	Inspect water pump and replace if needed
	Blocked cooling air inlet or exhaust	Inspect and remove any obstructions
	Defective or grounded temperature switch	Inspect switch and repair or replace
	Defective injectors or injector pump	Have the engine inspected by a trained service technician
	Defective oil pump	Have the engine inspected by a trained service technician
	Defective or grounded oil pressure switch	Inspect switch and repair or replace

IF YOU FEEL AN ELECTRIC SHOCK AT ANY TIME WHILE OPERATING THIS UNIT, SHUT IT DOWN IMMEDIATELY! HAVE THE UNIT INSPECTED BY A TRAINED ELECTRICIAN.

THIS ENGINE/GENERATOR SET IS FACTORY INSTALLED, TESTED, AND SET FOR FIELD OPERATION. ANY DAMAGE TO THE ENGINE OR GENERATOR UNITS OCCURRING AFTER ADJUSTMENTS ARE MADE IN THE FIELD BY UNAUTHORIZED PERSONNEL WILL NOT BE COVERED BY YOUR MANUFACTURER'S WARRANTY AND WILL ALSO VOID THE MANUFACTURER'S WARRANTY ON THIS PARTICULAR UNIT. IF YOU CAN NOT REACH YOUR LOCAL DEALER, CONTACT THE FACTORY SERVICE MANAGER TOLL FREE AT 1-800-433-3026.

Electrical Troubleshooting

5 Components that cause voltage related problems

Potentiometer

Connects to voltage regulator. Bypass potentiometer by unplugging from voltage regulator and installing jumper on 2 male spades on regulator.

Voltage Regulator

(Located inside the generator rear housing.)

Measure DC voltage at F1 & F2. Normal voltage is 10 to 12 V DC. Remove 2 wires marked (F1, X)(F2, X X) from voltage regulator. Connect wire marked F1 to positive and F2 to negative of a 12 volt battery. Start unit and measure voltage. If unit produces close to maximum output, replace Automatic Voltage Regulator.

Voltage Selector Switch

The correct way to test is to disconnect from generator and hard wire the generator into one configuration. This will eliminate the switch from the circuit and verify that the generator is functioning properly. All contacts should be checked following the proper schematic with the switch disconnected from the generator set. Actual loads can cause failures in contacts that cannot be duplicated using a meter.

Overcurrent Relay

This device causes the 3-phase breaker to trip that supplies AC power to the distribution lugs if uneven or excessive current is measured at the distribution lugs. It is also connected to the 3-phase door switch and will automatically trip the 3-phase breaker when the door is open and prevents the breaker from being reset while it is open.

Generator

Test resistance of field, stator and exciter windings. Contact **TEREX** for procedures or repair facility recommended by generator manufacturer.



Procedure for testing generator with no output

THIS EQUIPMENT USES HIGH VOLTAGE CIRCUITS CAPABLE OF CAUSING SERIOUS INJURY OR DEATH! EXERCISE EXTREME CAUTION AROUND ANY ELECTRICAL COMPONENT WHEN OPERATING THIS UNIT.

IT IS ESSENTIAL THAT ALL TEST INSTRUMENTS ARE REGULARLY CHECKED FOR SAFETY, AND ANY CONNECTION LEADS, PROBES, OR CLIPS, ARE CHECKED TO ENSURE THAT THEY ARE SUITABLE FOR THE VOLTAGE LEVELS BEING TESTED.

NEVER ATTEMPT TO TEST A "LIVE" GENERATOR UNLESS THERE IS ANOTHER COMPETENT PERSON PRESENT WHO CAN SWITCH OFF THE POWER SUPPLY OR SHUT DOWN THE ENGINE IN AN EMERGENCY.

NEVER EXPOSE "LIVE" CONNECTIONS UNLESS YOU HAVE CREATED A SAFE WORKING AREA AROUND YOU. MAKE SURE YOU HAVE MADE ALL OTHER PERSONS IN THE IMMEDIATE AREA FULLY AWARE OF WHAT YOU ARE DOING.

- When a new generator is not producing voltage, the testing or wiring personnel should first verify that the unit is wired correctly! The stack switch and generator leads should all be checked as well as the breaker and sensing leads. If the unit was not wired correctly and you flashed the generator, you could burn up the unit. **(Do not forget to check the sensing leads!).**

TROUBLESHOOTING

 **Procedure for testing generator with no output (cont.)**

- After performing the initial checks above, remove the field wires from the voltage regulator (F1 or X is positive and F2 or XX is negative). Connect the battery + to the F1 or X wire and battery - to the F2 or XX wire. Start the engine and check for the rated voltage. **Hooking this up incorrectly will reverse polarity and could damage the voltage regulator and /or generator end.** This check should correct any voltage problems. If your voltage does not come up to the rated voltage, this indicates an internal problem with the generator end. The output should be close to proper voltage. Also, if the unit comes up to voltage, check for even reading across the lines if they are not this would mean you probably have a problem with the wiring of the switch or generator. If the generator voltage reads correctly you know there is not a problem with the generator end. Your problem is more than likely with the voltage regulator. In this case, you should contact the **TEREX** service department.
- If the voltage is uneven between the legs when you apply 24 volts to the field wires you need to recheck your wiring connections. **(If you can not find the problem hard wire the generator!)** After you have the field wire connected start the unit again and check your output voltage. It may still be necessary to flash the fields to restore residual voltage. This needs to be done with the unit off and the field wires removed. **(Do not flash the regulator, flash the field wires)**
- As with any electrical device use extreme caution when working around a running generator it could cost you your life. Observe proper polarity when working with the regulator so you don't break something that is not broken to begin with, and if you are ever in doubt, ask.

INSTALLATION AND ANY WORK PERFORMED ON THIS UNIT SHOULD BE DONE ONLY BY A QUALIFIED ELECTRICIAN.

 **Procedure for changing the voltage potentiometer**

THIS EQUIPMENT USES HIGH VOLTAGE CIRCUITS CAPABLE OF CAUSING SERIOUS INJURY OR DEATH! EXERCISE EXTREME CAUTION AROUND ANY ELECTRICAL COMPONENT WHEN OPERATING THIS UNIT.

INSTALLATION AND ANY WORK PERFORMED ON THIS UNIT SHOULD BE DONE ONLY BY A QUALIFIED ELECTRICIAN.

- Make sure generator is turned off and e-stop is engaged before opening control panel.
- Locate the two wires going to the back of the potentiometer. Both wires will be white with a red stripe.
- Disconnect both wires.
- Once the wires are loose, go to the front of the control panel and loosen the lock nut holding the potentiometer.
- Put the new potentiometer in its place and retighten lock nut.
- Reattach the disconnected wires that were disconnected in step 3.
- After completing the installation of the new potentiometer go back and check all connections to make sure everything is tight and that no connections are loose, this includes all other wiring on the back of the control panel and on the inside of the control box.
- You should now be able to restart the generator and check for proper operation.

If any further adjustment is needed to the voltage of the generator please call **TEREX** at 1-800-433-3026 for assistance.

REV A



Observe and Obey:

- ☑ Troubleshooting and repair procedures shall be completed by a person trained and qualified on the repair of this machine.
- ☑ Immediately tag and remove from service a damaged or malfunctioning machine.
- ☑ Repair any machine damage or malfunction before operating the machine.

Before Troubleshooting:

- ☑ Read, understand and obey the safety rules and operating instructions in the appropriate operator's manual on your machine.
- ☑ Be sure that all necessary tools and test equipment are available and ready for use.

About This Section

There are two groups of schematics in this section. An illustration legend precedes each group of drawings.

Electrical Schematics

⚠WARNING Electrocution hazard. Contact with electrically charged circuits could result in death or serious injury. Remove all rings, watches and other jewelry.

General Repair Process

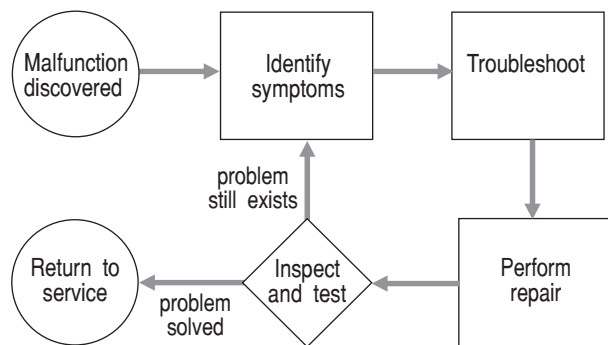

Control Panel Wiring

for Murphy Cascade Controller
Drawing #ES10001 (Standard)

REV A

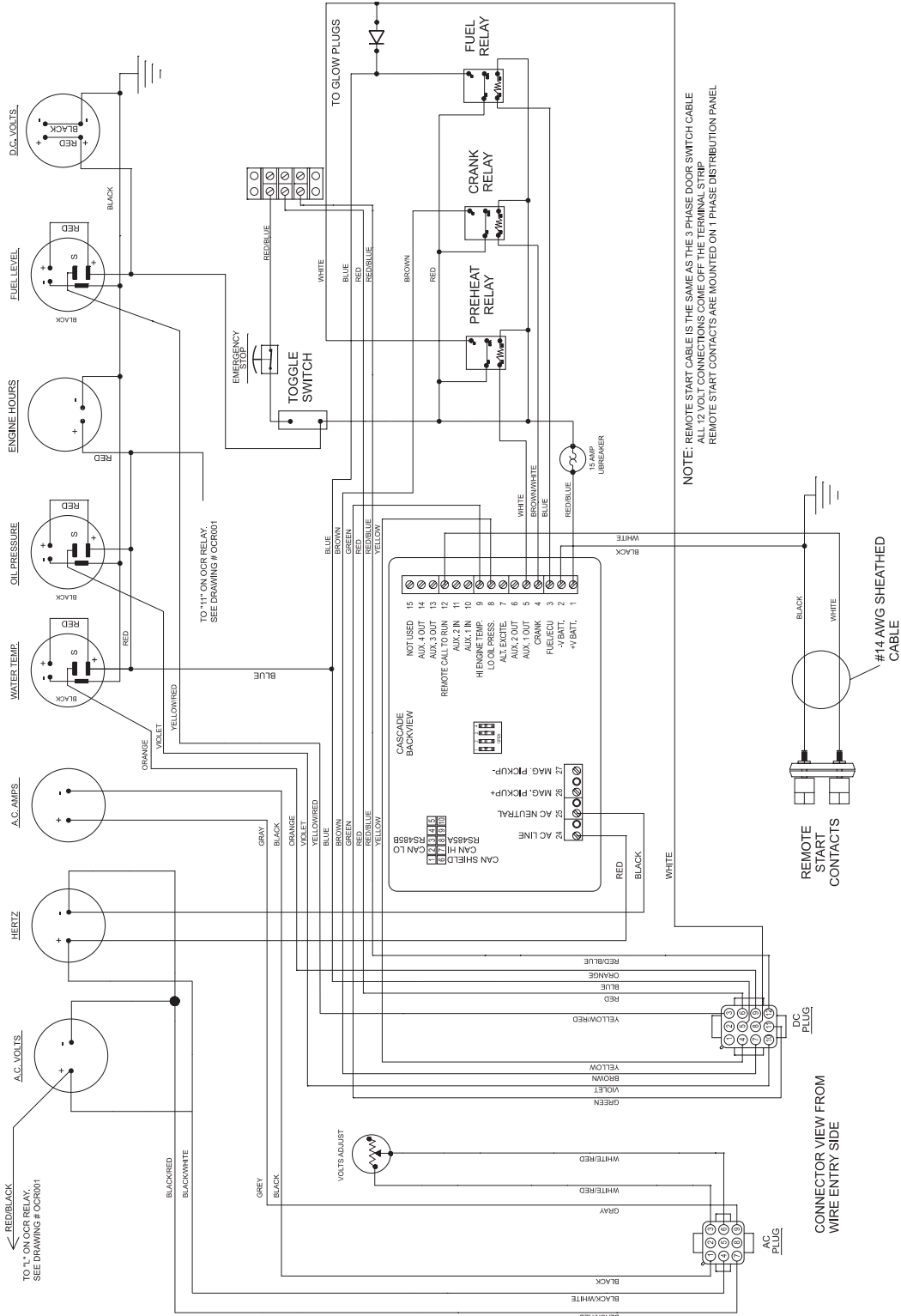



Control Panel Wiring

for Cascade w/Electronic Governor Drawing #ES10000 (Optional)

REV A

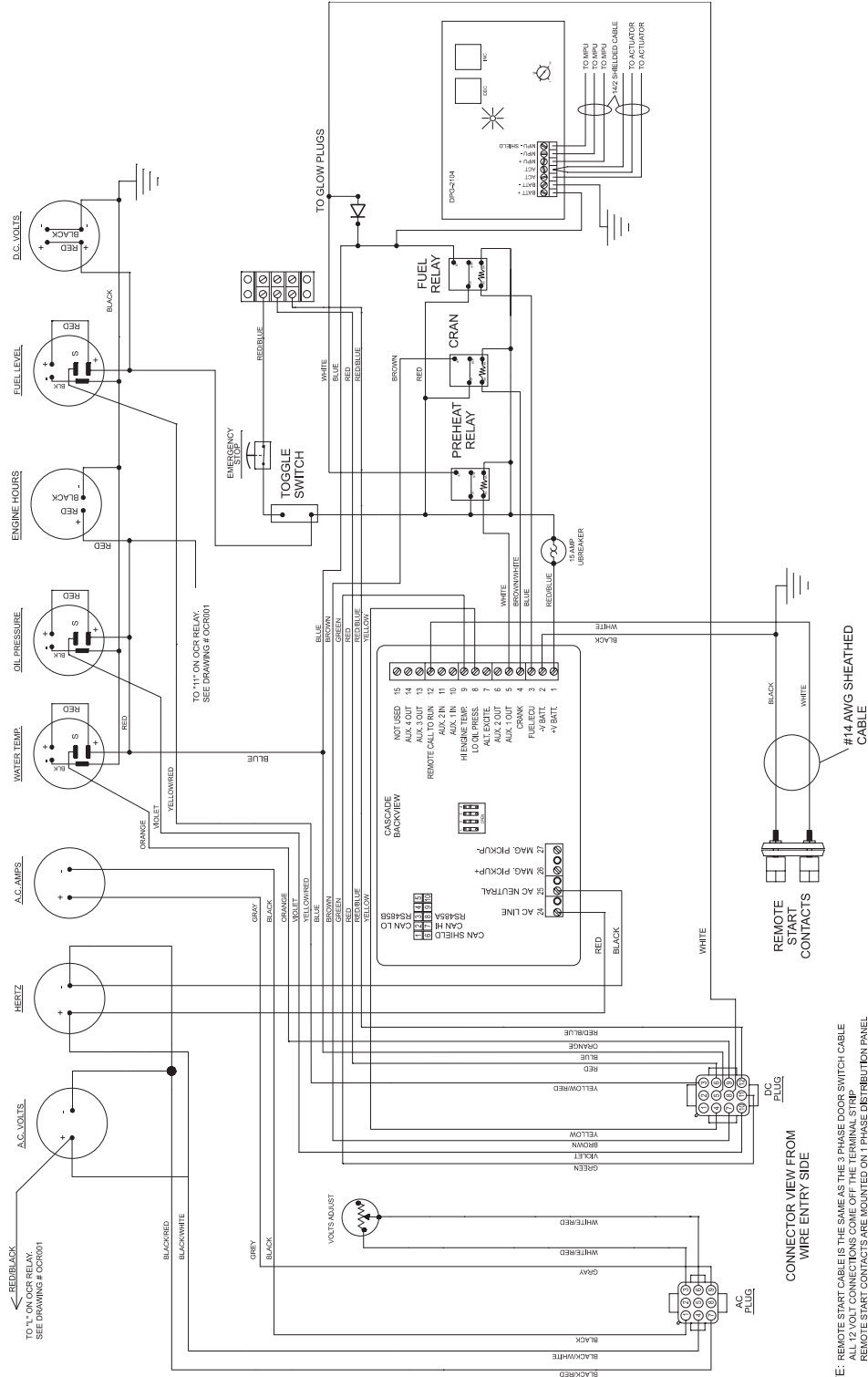

NOTE: REMOTE START CABLE IS THE SAME AS THE 3 PHASE DOOR SWITCH CABLE
 ALL 12 VOLT CONNECTIONS COME OFF THE TERMINAL STRIP
 REMOTE START CONTACTS ARE MOUNTED ON 1 PHASE DISTRIBUTION PANEL

Distribution Panel Wiring

for T25I & T45I Series Single Phase Control
 Drawing #ES100003

REV A

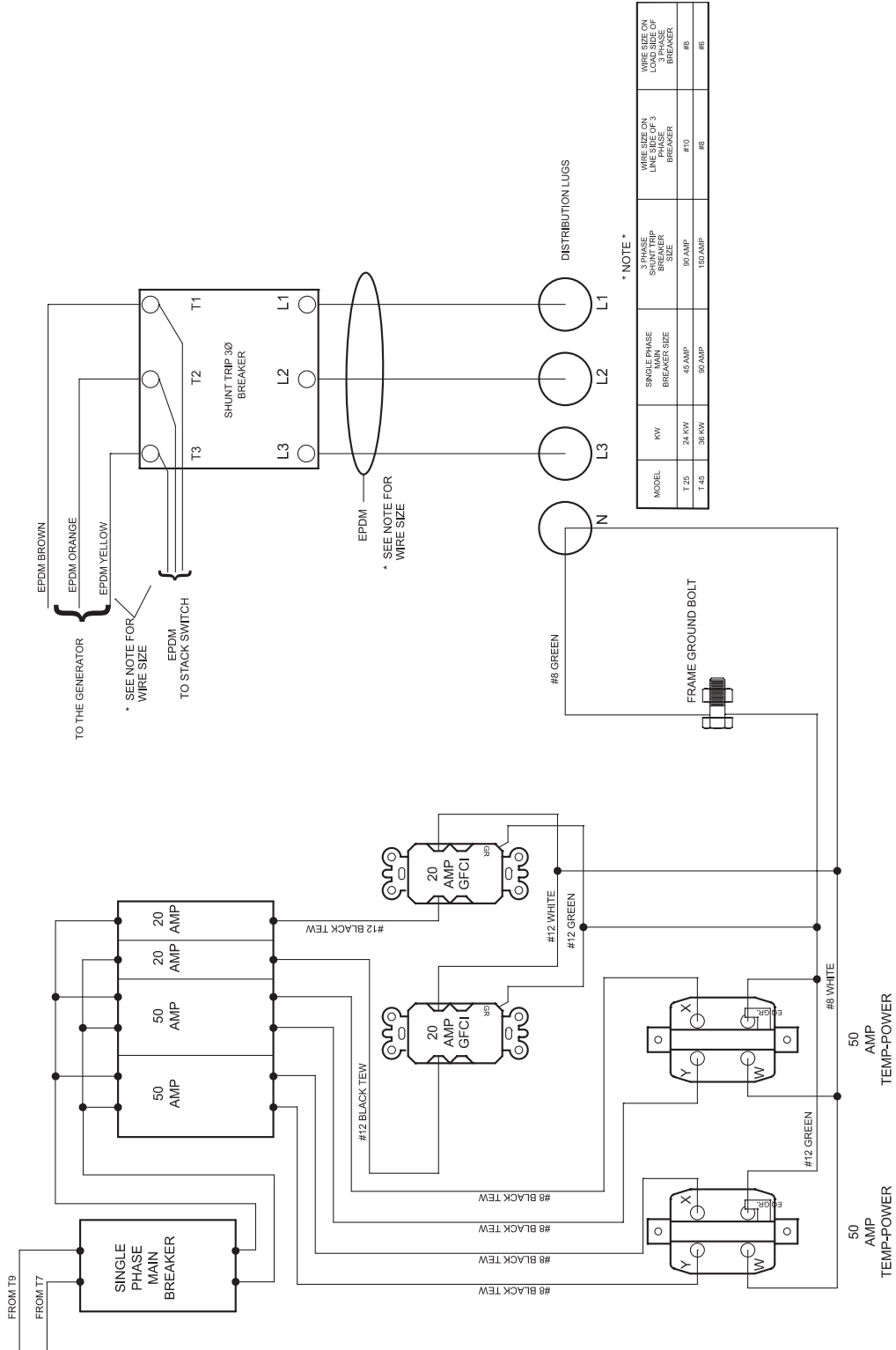



Three Position Stack Switch Wiring

Drawing #ES100005

REV A

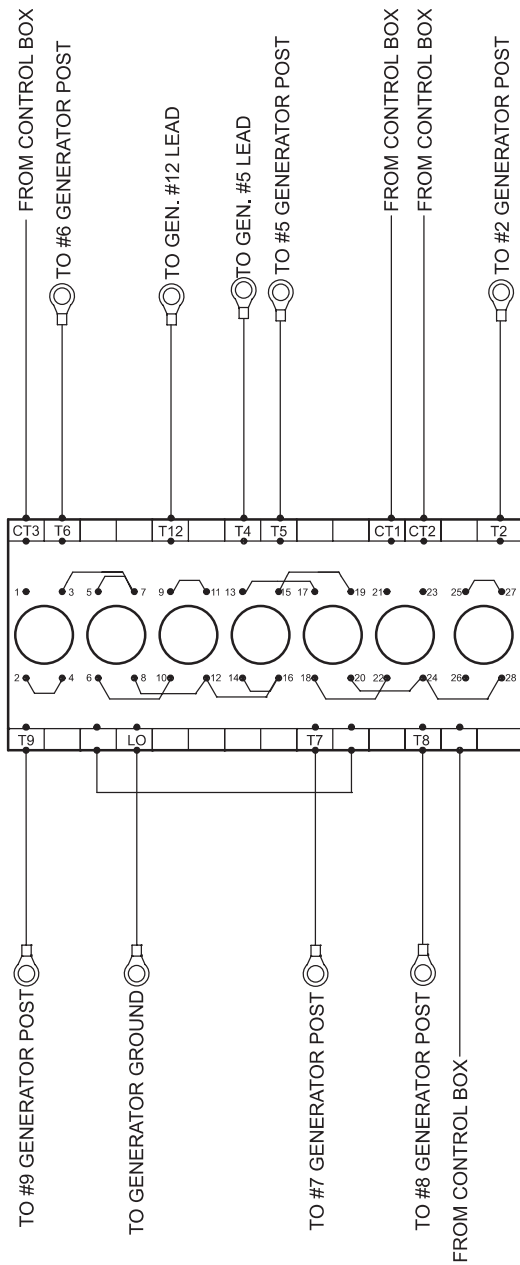

GENERATOR	STACK SWITCH #	WIRE SIZE
T25I	C42201102	10 GA. EPDM
T45I	C42202402	8 GA. EPDM

NOTE: FOR REFERENCE SEE DRAWINGS #ES100007 & ES100008

Overcurrent Relay Wiring

Drawing #ES100006

REV A

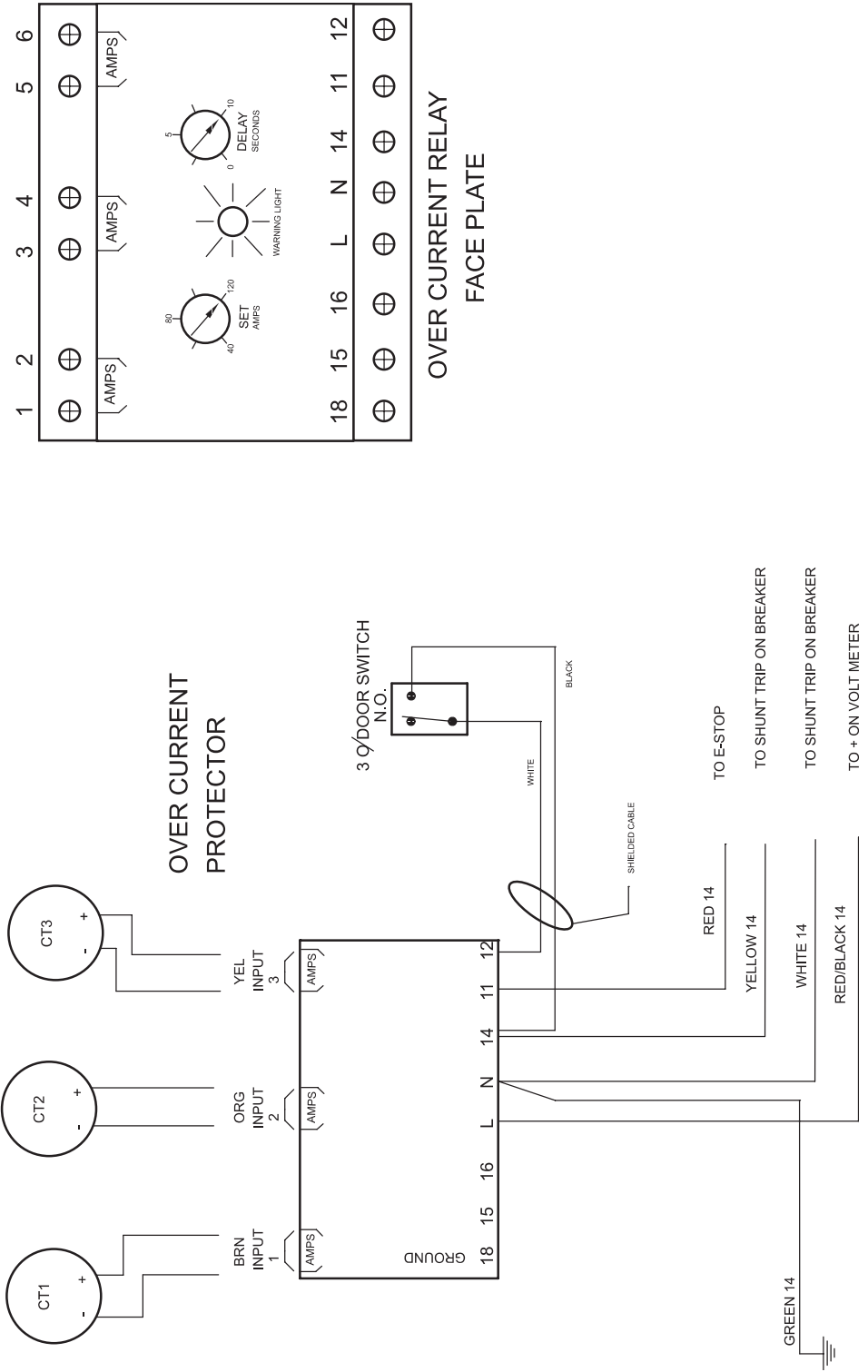



Generator Wiring Breakdown

Drawing #ES100007

REV A



GENERATOR
TOPPOSTS

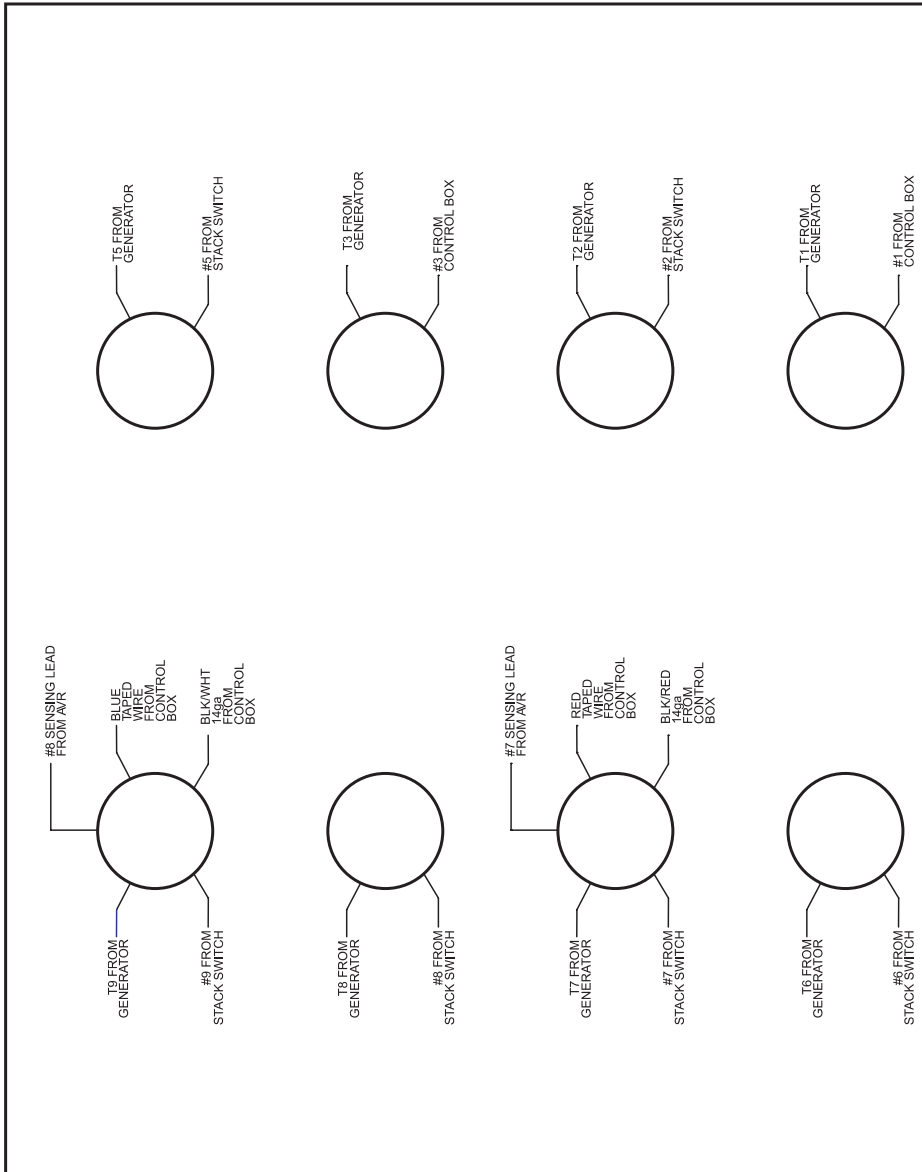

- F1 AND F2 FROM GENERATOR TO AVR
- #4 FROM GENERATOR TO #4 FROM STACK SWITCH
- #12 FROM GENERATOR TO #12 FROM STACK SWITCH
- BROWN TAPED WIRE FROM CONTROL BOX TO #21 POSITION ON STACK SWITCH
- ORANGE TAPED WIRE FROM CONTROL BOX TO #23 POSITION ON STACK SWITCH
- YELLOW TAPED WIRE FROM CONTROL BOX TO #1 POSITION ON STACK SWITCH
- #2 ORANGE TAPED WIRE FROM CONTROL BOX TO #26 POSITION ON STACK SWITCH



Standard Generator Wiring

Drawing #ES1000008

REV A

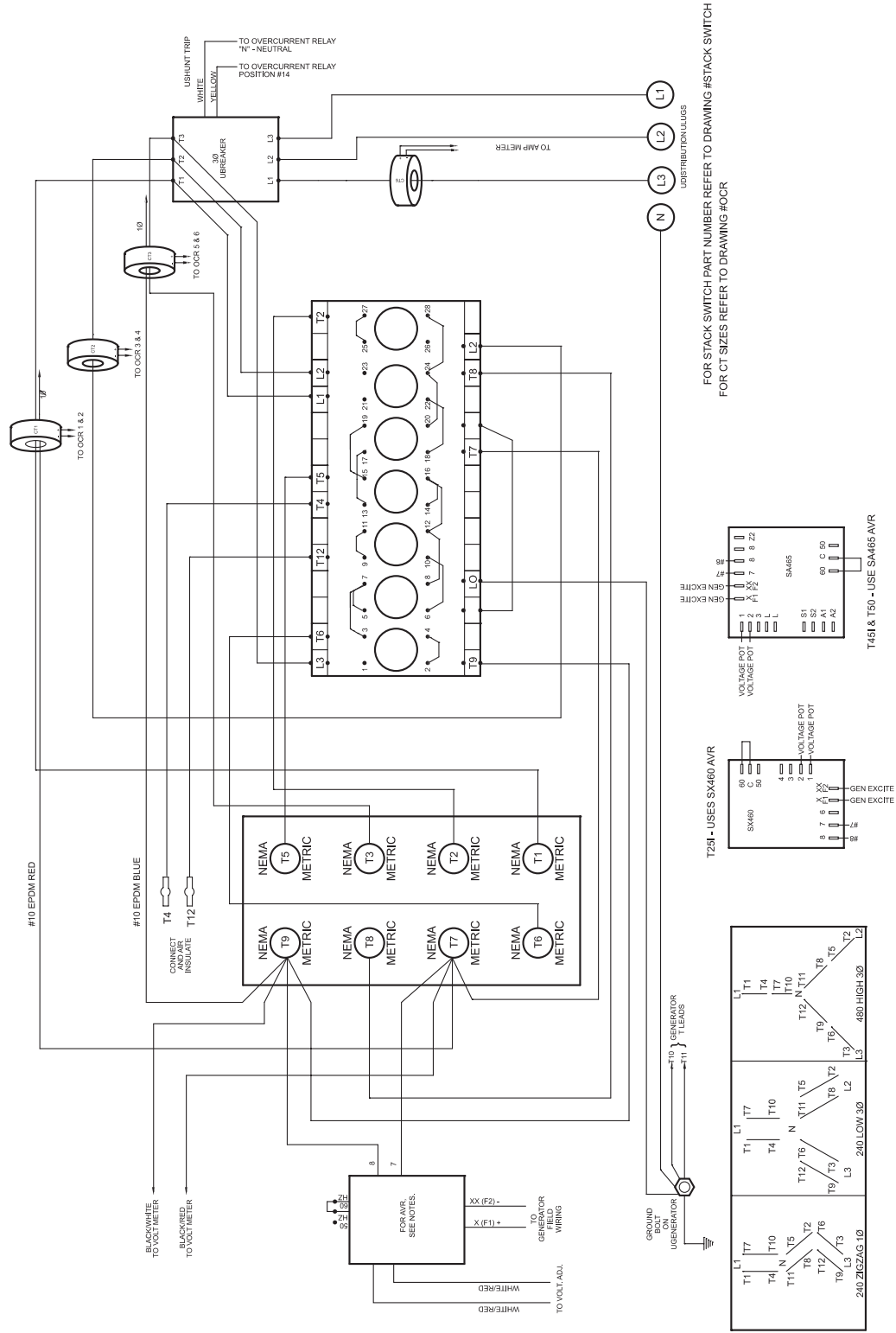

FOR STACK SWITCH PART NUMBER REFER TO DRAWING #STACK SWITCH
 FOR CT SIZES REFER TO DRAWING #OCR

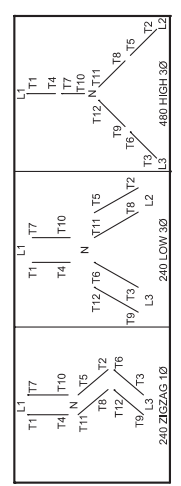
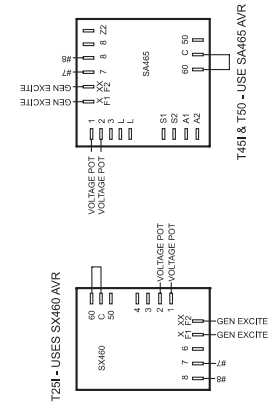

California Proposition 65

Warning

The exhaust from this product contains chemicals known to the State of California to cause cancer, birth defects or other reproductive harm.

Towing Checklist

(Use at each stop)

Before Towing

- Towing hitch is properly secured to tow vehicle
- Safety chains (if required) are properly attached and secure (chains are crossed below hitch)
- All lights are connected and working
- Tires are properly inflated

Before Driving

- Fasten safety restraints
- Properly adjust mirrors

On The Road

- Do not exceed 60 mph / 97 km/h. Obey all local and national towing speed laws
- Check connections and tire pressure at each stop
- Slow down for hazardous conditions
- Allow extra distance for following and passing other vehicles

Genie North America
Phone 425.881.1800
Toll Free USA and Canada
800.536.1800
Fax 425.883.3475

Genie Australia Pty Ltd.
Phone +61 7 3375 1660
Fax +61 7 3375 1002

Genie China
Phone +86 21 53852570
Fax +86 21 53852569

Genie Malaysia
Phone +65 98 480 775
Fax +65 67 533 544

Genie Japan
Phone +81 3 3453 6082
Fax +81 3 3453 6083

Genie Korea
Phone +82 25 587 267
Fax +82 25 583 910

Genie Brasil
Phone +55 11 41 665 755
Fax +55 11 41 665 754

Genie Holland
Phone +31 183 581 102
Fax +31 183 581 566

Genie Scandinavia
Phone +46 31 575100
Fax +46 31 579020

Genie France
Phone +33 (0)2 37 26 09 99
Fax +33 (0)2 37 26 09 98

Genie Iberica
Phone +34 93 579 5042
Fax +34 93 579 5059

Genie Germany
Phone +49 (0)4202 88520
Fax +49 (0)4202 8852-20

Genie U.K.
Phone +44 (0)1476 584333
Fax +44 (0)1476 584334

Genie Mexico City
Phone +52 55 5666 5242
Fax +52 55 5666 3241

Distributed By: