

---

# EVOLVER™ SOLVENTBORNE ROBOTIC ATOMIZERS

---

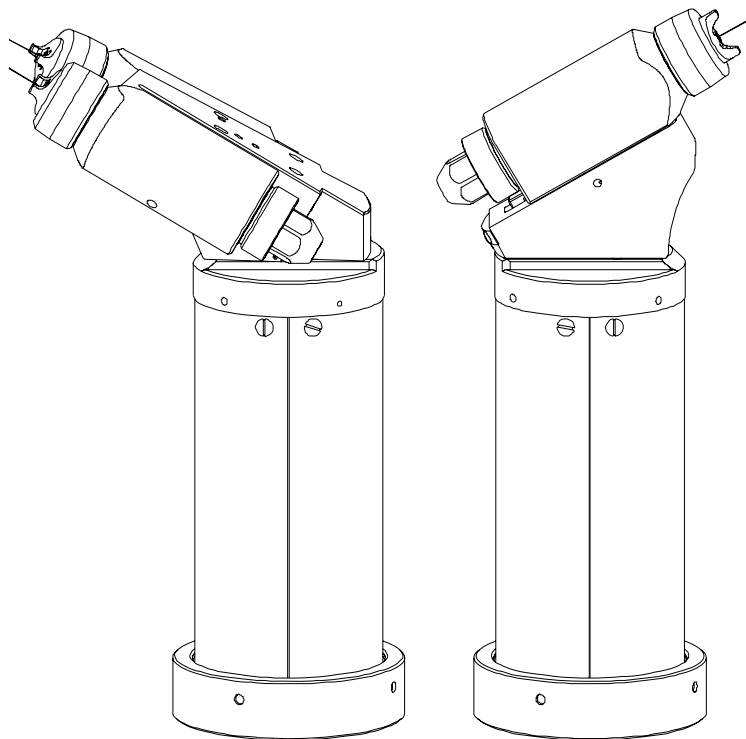

**MODEL: 79190-XXXXXXXX**



**APPROVED**

**IMPORTANT:** Before using this equipment, carefully read **SAFETY PRECAUTIONS**, starting on page 1, and all instructions in this manual. Keep this Service Manual for future reference.

Service Manual Price: €40.00 (Euro)  
\$50.00 (U.S.)

**NOTE:** This manual has been changed from revision **AA-03-02.9** to revision **AA-03-02.10**. Reasons for this change are noted under “Manual Change Summary” inside the back cover of this manual.

# CONTENTS

	<b>PAGE</b>
<b>SAFETY:</b>	<b>1-4</b>
SAFETY PRECAUTIONS.....	1
HAZARDS/SAFEGUARDS.....	2-4
<b>ATEX</b>	<b>5-6</b>
EUROPEAN ATEX DIRECTIVE.....	5
EUROPEAN ATEX LABELS.....	6
<b>INTRODUCTION:</b>	<b>7-14</b>
ITW RANSBURG ELECTROSTATIC PROCESS.....	7
EVOLVER SOLVENTBORNE GUNS.....	7-8
SPECIFICATIONS.....	8
EVOLVER GUN SELECTION GUIDE.....	9-10
EVOLVER SOLVENTBORNE ROBOTIC ATOMIZER	11
GUNS FEATURES.....	12
79190-XXXXXXX EVOLVER GUN ASSEMBLY.....	13
<b>INSTALLATION:</b>	<b>15-20</b>
EVOLVER ROBOTIC ATOMIZER INSTALLATION.....	15
POWER SUPPLY ASSEMBLY.....	15
LOW VOLTAGE CABLE CONNECTIONS.....	16
GUN AND MANIFOLD ASSEMBLY / PARTS LIST.....	17-20
<b>OPERATION:</b>	<b>21-24</b>
SPRAY GUN CONTROLS.....	21
HVLP SPRAY.....	21
BACK PRESSURE - 48-1 & 481-1.....	21
FLUID VALVE CONTROLS.....	22
DUAL PURGE SPRAYING.....	22-23
SIMPLIFIED AIR AND FLUID FLOW PASSAGE LAYOUT.....	24
<b>MAINTENANCE:</b>	<b>25-52</b>
ROUTINE MAINTENANCE SCHEDULE.....	25-26
PROCEDURES.....	26-27
SPRAY HEAD REMOVAL ASSEMBLY / PARTS LIST.....	29-30
SERVICE.....	31
SPRAY HEAD ASSEMBLY.....	31-33
79138 EVOLVER GUN HEAD ASSEMBLY / PARTS LIST.....	35-36
REMOVING GUN FROM THE REAR MANIFOLD ASSEMBLY.....	37

(Continued On Next Page)

	<b>PAGE</b>
<b>MAINTENANCE (Cont.):</b>	<b>25-52</b>
79190 EVOLVER GUN ASSEMBLY / PARTS LIST.....	38
MOUNTING BLOCK, SHROUD HALVES & RETAINING RING REMOVAL / PARTS LIST.....	39-40
DISASSEMBLY OF INTERMEDIATE GUN HOUSING / PARTS LIST.....	41-42
VALVE MANIFOLD DISASSEMBLY / PARTS LIST.....	43-44
LOW VOLTAGE CABLE REMOVAL / PARTS LIST.....	45-46
FLUID REGULATOR (When Equipped).....	46-47
FLUID REGULATOR ASSEMBLY / PARTS LIST.....	48
A10406 OR LECU5004 MICROPAK CONTROL UNIT.....	49
ACCESSORIES.....	49-50
TROUBLESHOOTING GUIDE.....	51-52
<b>PARTS IDENTIFICATION:</b>	<b>53-78</b>
79190-XXXXXXX GUN ASSEMBLY / PARTS LIST.....	53-56
SPRAYHEAD ASSEMBLY.....	57
79138-01 CONVENTIONAL SPRAY HEAD ASSEMBLY / PARTS LIST.....	58
79138-02 HVLP SPRAY HEAD ASSEMBLY PARTS LIST.....	59
79179-00 SINGLE HEAD 60° / PARTS LIST.....	60
79243-00 DUAL HEAD 60° / PARTS LIST.....	60
79180-00 SINGLE HEAD 90° / PARTS LIST.....	61
79224-00 DUAL HEAD 90° / PARTS LIST.....	61
79175-XX MANIFOLD ASSEMBLY.....	62
79175-XX OPTIONAL REGULATED VERSION.....	63
79175-XX MANIFOLD ASSEMBLY PARTS LIST.....	64-65
79175-07 MANIFOLD ASSEMBLY (ONLY) / PARTS LIST.....	67-68
79156 REAR TUBING MANIFOLD ASSEMBLY - ENGLISH / PARTS LIST.....	69-71
A10853 REAR TUBING MANIFOLD ASSEMBLY - METRIC / PARTS LIST.....	72-74
SIGNAL IDENTIFICATION TABLE - ENGLISH AND METRIC.....	75
SERVICE PARTS.....	76
REPAIR KITS.....	77-78
<b>WARRANTY POLICIES:</b>	<b>79</b>
LIMITED WARRANTY.....	79



# SAFETY

## SAFETY PRECAUTIONS

Before operating, maintaining or servicing any ITW Ransburg electrostatic coating system, read and understand all of the technical and safety literature for your ITW Ransburg products. This manual contains information that is important for you to know and understand. This information relates to **USER SAFETY** and **PREVENTING EQUIPMENT PROBLEMS**. To help you recognize this information, we use the following symbols. Please pay particular attention to these sections.

**A WARNING!** states information to alert you to a situation that might cause serious injury if instructions are not followed.

**A CAUTION!** states information that tells how to prevent damage to equipment or how to avoid a situation that might cause minor injury.

**A NOTE** is information relevant to the procedure in progress.

While this manual lists standard specifications and service procedures, some minor deviations may be found between this literature and your equipment. Differences in local codes and plant requirements, material delivery requirements, etc., make such variations inevitable. Compare this manual with your system installation drawings and appropriate Ransburg equipment manuals to reconcile such differences.



Careful study and continued use of this manual will provide a better understanding of the equipment and process, resulting in more efficient operation, longer trouble-free service and faster, easier troubleshooting. If you do not have the manuals and safety literature for your ITW Ransburg system, contact your local ITW Ransburg representative or ITW Ransburg.



### WARNING

- ▶ The user **MUST** read and be familiar with the Safety Section in this manual and the ITW Ransburg safety literature therein identified.
- ▶ This manual **MUST** be read and thoroughly understood by **ALL** personnel who operate, clean or maintain this equipment! Special care should be taken to ensure that the **WARNINGS** and safety requirements for operating and servicing the equipment are followed. The user should be aware of and adhere to **ALL** local building and fire codes and ordinances as well as **NFPA-33 SAFETY STANDARD**, prior to installing, operating, and/or servicing this equipment.

### WARNING

- ▶ The hazards shown on the following page may occur during the normal use of this equipment. Please read the hazard chart beginning on page 2.

<b>AREA</b> Tells where hazards may occur.	<b>HAZARD</b> Tells what the hazard is.	<b>SAFEGUARDS</b> Tells how to avoid the hazard.
<p><b>Spray Area</b></p> 	<p><b>Fire Hazard</b></p> <p>Improper or inadequate operation and maintenance procedures will cause a fire hazard.</p> <p>Protection against inadvertent arcing that is capable of causing fire or explosion is lost if any safety interlocks are disabled during operation. Frequent power supply shut-down indicates a problem in the system requiring correction.</p>	<p>Fire extinguishing equipment must be present in the spray area and tested periodically.</p> <p>Spray areas must be kept clean to prevent the accumulation of combustible residues.</p> <p>Smoking must never be allowed in the spray area.</p> <p>The high voltage supplied to the atomizer must be turned off prior to cleaning, flushing or maintenance.</p> <p>When using solvents for cleaning:</p> <p>Those used for equipment flushing should have flash points equal to or higher than those of the coating material.</p> <p>Those used for general cleaning must have flash points above 100°F (37.8°C).</p> <p>Spray booth ventilation must be kept at the rates required by NFPA-33, OSHA, and local codes. In addition, ventilation must be maintained during cleaning operations using flammable or combustible solvents.</p> <p>Electrostatic arcing must be prevented.</p> <p>Test only in areas free of combustible material.</p> <p>Testing may require high voltage to be on, but only as instructed.</p> <p>Non-factory replacement parts or unauthorized equipment modifications may cause fire or injury.</p> <p>If used, the key switch by-pass is intended for use only during set-up operations. Production should never be done with safety interlocks disabled.</p> <p>Never use equipment intended for use in waterborne installations to spray solvent based materials.</p> <p>The paint process and equipment should be set up and operated in accordance with NFPA-33, NEC, and OSHA requirements.</p>
<p><b>General Use and Maintenance</b></p> 	<p>Improper operation or maintenance may create a hazard.</p> <p>Personnel must be properly trained in the use of this equipment.</p>	<p>Personnel must be given training in accordance with the requirements of NFPA-33.</p> <p>Instructions and safety precautions must be read and understood prior to using this equipment.</p> <p>Comply with appropriate local, state, and national codes governing ventilation, fire protection, operation maintenance, and housekeeping. Reference OSHA, NFPA-33, and your insurance company requirements.</p>

<b>AREA</b> Tells where hazards may occur.	<b>HAZARD</b> Tells what the hazard is.	<b>SAFEGUARDS</b> Tells how to avoid the hazard.
<b>Electrical Equipment</b>  	<p>High voltage equipment is utilized. Arcing in areas of flammable or combustible materials may occur. Personnel are exposed to high voltage during operation and maintenance.</p> <p>Protection against inadvertent arcing that may cause a fire or explosion is lost if safety circuits are disabled during operation.</p> <p>Frequent power supply shutdown indicates a problem in the system which requires correction.</p> <p>An electrical arc can ignite coating materials and cause a fire or explosion.</p>	<p>The power supply, optional remote control cabinet, and all other electrical equipment must be located outside Class I or II, Division 1 and 2 hazardous areas. Refer to NFPA-33.</p> <p>Turn the power supply OFF before working on the equipment.</p> <p>Test only in areas free of flammable or combustible material.</p> <p>Testing may require high voltage to be on, but only as instructed.</p> <p>Production should never be done with the safety circuits disabled.</p> <p>Before turning the high voltage on, make sure no objects are within the sparking distance.</p>
<b>Explosion Hazard/ Incompatible Materials</b>  	<p>Halogenated hydrocarbon solvents for example: methylene chloride and 1,1,1,-Trichlor-oethane are not chemically compatible with the aluminum that might be used in many system components. The chemical reaction caused by these solvents reacting with aluminum can become violent and lead to an equipment explosion.</p>	<p>Aluminum is widely used in other spray application equipment - such as material pumps, regulators, triggering valves, etc. Halogenated hydrocarbon solvents must never be used with aluminum equipment during spraying, flushing, or cleaning. Read the label or data sheet for the material you intend to spray. If in doubt as to whether or not a coating or cleaning material is compatible, contact your material supplier. Any other type of solvent may be used with aluminum equipment.</p>
<b>Toxic Substances</b>  	<p>Certain material may be harmful if inhaled, or if there is contact with the skin.</p>	<p>Follow the requirements of the Material Safety Data Sheet supplied by coating material manufacturer.</p> <p>Adequate exhaust must be provided to keep the air free of accumulations of toxic materials.</p> <p>Use a mask or respirator whenever there is a chance of inhaling sprayed materials. The mask must be compatible with the material being spray-ed and its concentration. Equipment must be as prescribed by an industrial hygienist or safety expert, and be NIOSH approved.</p>



<b>AREA</b> Tells where hazards may occur.	<b>HAZARD</b> Tells what the hazard is.	<b>SAFEGUARDS</b> Tells how to avoid the hazard.
<p><b>Spray Area / High Voltage Equipment</b></p> 	<p>There is a high voltage device that can induce an electrical charge on objects which is capable of igniting coating materials.</p> <p>Inadequate grounding will cause a spark hazard. A spark can ignite many coating materials and cause a fire or explosion.</p>	<p>Parts being sprayed must be supported on conveyors or hangers and be grounded. The resistance between the part and ground must not exceed 1 megohm.</p> <p>All electrically conductive objects in the spray area, with the exception of those objects required by the process to be at high voltage, must be grounded.</p> <p>Any person working in the spray area must be grounded.</p> <p>Unless specifically approved for use in hazardous locations, the power supply and other electrical control equipment must not be used in Class 1, Division 1 or 2 locations.</p>
<p><b>Robot Work Area-General Use and Maintenance</b></p>	<p>Improper use or maintenance can lead to hazardous conditions, particularly from unexpected robot manipulator movement.</p>	<p>Applicator adjustments or maintenance should be done after the robot is taken out of service. Do not adjust or repair the applicator if the robot is operating or standing ready to start.</p> <p>Refer to robot operating instructions for the procedures to take the robot out of service.</p>
<p><b>Personnel Safety</b></p>	<p>Skin puncturing by sharp electrode.</p>	<p>Take precautions to see that flesh is not punctured by sharp electrode.</p>

---

## EUROPEAN ATEX DIRECTIVE 94/9/EC, ANNEX II, 1.0.6

---

The following instructions apply to equipment covered by certificate number Sira 05ATEX5127X:

1. The equipment may be used with flammable gases and vapors with apparatus groups II and with temperature class T6.
2. The equipment is only certified for use in ambient temperatures in the range +12.8°C to +55°C and should not be used outside this range.
3. Installation shall be carried out by suitably trained personnel in accordance with the applicable code of practice e.g. EN 60079-14:1997.
4. Inspection and maintenance of this equipment shall be carried out by suitably trained personnel in accordance with the applicable code of practice e.g. EN 60079-17.
5. Repair of this equipment shall be carried out by suitable trained personnel in accordance with the applicable code of practice e.g. EN 60079-19.
6. Putting into service, use, assembling, and adjustment of the equipment shall be fitted by suitably trained personnel in accordance with the manufacturer's documentation.

Refer to the "Table of Contents" of this service manual.

- a. Installation
- b. Operation
- c. Maintenance
- d. Parts Identification

7. Components to be incorporated into or used as replacement parts of the equipment shall be fitted by suitably trained personnel in accordance with the manufacturer's documentation.

8. The certification of this equipment relies upon the following materials used in its construction: If the equipment is likely to come into contact with aggressive substances, then it is the responsibility

of the user to take suitable precautions that prevent it from being adversely affected, thus ensuring that the type of protection provided by the equipment is not compromised.

Aggressive substances: e.g. acidic liquids or gases that may attack metals, or solvents that may affect polymeric materials.

Suitable precautions: e.g. regular checks as part of routine inspections or establishing from the material's data sheets that it is resistant to specific chemicals.

Refer to "Specifications" in the "Introduction" section:

- a. All fluid passages contain stainless steel or nylon fittings.
- b. High voltage cascade is encapsulated with a solvent resistant epoxy.

9. A recapitulation of the certification marking is detailed in the "ATEX" section, on the next page, drawing numbers: A10752, A10754, A10755, and A10915.

10. The characteristics of the equipment shall be detailed e.g. electrical, pressure, and voltage parameters.

**The manufacturer should note that, on being put into service, the equipment must be accompanied by a translation of the instructions in the language or languages of the country in which the equipment is to be used and by the instructions in the original language.**

### Evolver 79190 ATEX Product Marking Definitions

Ex Certificate Number: Sira 05 ATEX 5 127 X

- Sira = Notified Body performing EC-type examination
- 05 = Year of certification
- ATEX = Reference to ATEX Directive
- 5 = Protection Concept Code (code 5 is titled Encapsulation)
- 127 = Document serial number
- X = Special conditions for safe use apply

Special conditions for safe use: The Evolver 79190 Series Automatic Atomizers shall only be used with associated Micropak A10406 or LECU5004-31 Power Supplies.

### Product Marking



- Ex = Specific marking of explosive protection
- II = Equipment Group hazardous area characteristics
- 2 = Equipment Category
- G = Type of explosive atmosphere (gases, vapors, or mists)

**EEx 0.24mJ** = The Evolver 79190 Series of automatic atomizers are suitable for use in automatic spraying installations complying with EN 50176 as they are a Type A class with a discharge energy limit of 0.24mJ.

### Label A10754

**ITW Ransburg, Angola, IN, USA**  
Electrostatic Systems

SIRA 05ATEX5127X

APPROVED

APPROVED FOR ELECTROSTATIC FINISHING APPLICATIONS USING CLASS I, GROUP D, SPRAY MATERIAL.  
OPERATING TEMPERATURE RANGE: 55°F(12.8°C)–131°F(55°C)  
EVOLVER™ GUN ATOMIZER SYSTEM WHICH CONSISTS OF THE FOLLOWING:

79190(ALL VER.) EVOLVER™ SINGLE 60° GUN ATOMIZER	79190(ALL VER.) EVOLVER™ SINGLE 90° GUN ATOMIZER
79190(ALL VER.) EVOLVER™ DUAL 60° GUN ATOMIZER	79190(ALL VER.) EVOLVER™ DUAL 90° GUN ATOMIZER
7900B-25(or 50,75,100) LOW VOLTAGE CABLE ASSEMBLY	A10406-01(or 02) POWER SUPPLY
LECU5004-31 MICROPAK CONTROLLER	

### Label A10755

**ITW Ransburg, Angola, IN, USA**  
Electrostatic Systems

SIRA 05ATEX5127X

APPROVED

**WARNING**  
FAILURE TO OBSERVE THE FOLLOWING PRECAUTIONS MAY RESULT IN AN ELECTRICAL DISCHARGE CAPABLE OF STARTING A FIRE.

- THE ARTICLE BEING COATED MUST BE GROUND.
- ALL OTHER ELECTRICALLY CONDUCTING OBJECTS WITHIN ABOUT TEN FEET OF THE OPERATING SPRAY GUN MUST BE GROUND.
- THIS CONTROL UNIT/POWER SUPPLY MUST BE INTERLOCKED WITH THE SPRAY BOOTH VENTILATORS SO AS TO PREVENT OPERATION OF THE POWER SUPPLY UNLESS VENTILATING FANS ARE IN OPERATION.
- SERVICE WARNING – ENCLOSURE PROTECTS AGAINST SHOCK AND INJURY. SERVICE TRAINING REQUIRED.

KEEP POWER SUPPLY OUTSIDE THE HAZARDOUS AREA.  
DO NOT ATTEMPT REPAIR BEFORE READING SERVICE MANUAL.  
FOR ELECTROSTATIC PAINT FINISHING APPLICATIONS THE SERIAL NUMBER INCLUDES THE DATE OF MANUFACTURE.

PART No.	INPT. VOLTAGE	SERIAL No.	INPT. CURRENT
	90–264 VAC		1.5 A MAX.
	47/63 Hz		1
	OUTPUT VOLTAGE		PHASE
	0–100KV DC		180 MAX.
	HUMIDITY		OUTPUT CURRENT
	95% NON-CONDENSING		85 uAmps MAX.
			TEMP
			0 TO 55 C

THE SPRAY GUN/CABLE ASSEMBLY IS ONLY "FM" & "SIRA" APPROVED WHEN USED WITH EITHER THE LECU5004-31 MICROPAK CONTROLLER ASSEMBLY OR THE A10406 STANDALONE CONTROL/POWER SUPPLY ASSEMBLY.

LABEL REMOVAL VOID WARRANTY

### Label A10915

**ITW Ransburg, Angola, IN, USA**  
Electrostatic Systems

SIRA 05ATEX5127X

APPROVED

PART No.	INPT. VOLTAGE	SERIAL No.	INPT. CURRENT
	24 VDC		2.5 A MAX.
			60 MAX.
	OUTPUT VOLTAGE		85 uAmps MAX.
	0–100 KV DC		OUTPUT CURRENT
	HUMIDITY		TEMP
	95% NON-CONDENSING		0 TO 55 C

- THE SERIAL NUMBER INCLUDES THE DATE OF MANUFACTURE.  
THE SPRAY GUN/CABLE ASSEMBLY IS ONLY "FM" & "SIRA" APPROVED WHEN USED WITH EITHER THE LECU5004-31 MICROPAK CONTROLLER ASSEMBLY OR THE A10406 STANDALONE CONTROL/POWER SUPPLY ASSEMBLY.

### Label A10752

**ITW Ransburg, Angola, IN, USA**  
Electrostatic Systems

ITW RANSBURG "EVOLVER" MODEL-79190 ALL VERSIONS FOR ELECTRO. FIN. APPL. CL.1, GP.D, SPRAY MAT'L. MADE IN U.S.A.

S/N:

EEx 0.24 mJ

SIRA 05ATEX5127X

APPROVED

**WARNING**  
SUBSTITUTION OF COMPONENTS MAY IMPAIR SAFETY RATINGS

- THE SERIAL NUMBER INCLUDES THE DATE OF MANUFACTURE.  
THE SPRAY GUN/CABLE ASSEMBLY IS ONLY "FM" & "SIRA" APPROVED WHEN USED WITH EITHER THE LECU5004-31 MICROPAK CONTROLLER ASSEMBLY OR THE A10406 STANDALONE CONTROL/POWER SUPPLY ASSEMBLY.

LABEL REMOVAL VOID WARRANTY

- 5 FILL IN AT TIME OF ASSEMBLY WITH THE NUMBER ASSIGNED TO THE NOTIFYING BODY RESPONSIBLE FOR THE QUALITY ASSURANCE NOTIFICATION FOR THE PRODUCTION PHASE.
- 4 FILL IN AT TIME OF ASSEMBLY WITH SERIAL NUMBER.

# INTRODUCTION

## THE ITW RANSBURG ELECTROSTATIC PROCESS

This process is a method for electrostatically applying coatings to objects. A power supply produces a high voltage charge which is supplied to the applicator, creating an electrostatic field between the applicator and the target object. The target is electrostatically grounded through its support which may be either stationary or moving.

A regulated fluid system delivers coating material to the applicator, where it is atomized forming a spray mist. There, under the influence of the electrostatic field, the atomized coating becomes electrostatically charged. The charged particles are attracted to and deposited on the grounded target object. The forces between the charged particles and the target are sufficient to turn overspray around and deposit it on the back surface of the target. Therefore, a higher percentage of the spray is deposited.

## EVOLVER SOLVENTBORNE GUNS

The *Evolver™ Solventborne Gun Line* consists of both 60° and 90° single and dual-headed 100 kV automatic electrostatic spray guns. Developed for use on robots, the Evolver gun incorporates a unique 1/3 turn quick-disconnect spray head and a two piece snap together manifold cover, providing the user an efficient tool for the electrostatic application of coatings.

The Evolver gun also has the ability to color change while spraying with no voltage draw down, a true dual purge function.

There are two single head models of the Evolver Gun (see Figure 1). Each model differs in the gun to axis orientation of the spray head. These models are:

- 79190-X0XXXXXX 60° Single Head
- 79190-X1XXXXXX 90° Single Head

Two dual-head versions of the Evolver Gun are also available (see Figure 1). The dual headed guns are primarily used where high volume fluid delivery is required. The dual headed gun is available in two different configurations as follows:

- 79190-X2XXXXXX 60° Dual Head
- 79190-X3XXXXXX 90° Dual Head

The Evolver Spray Gun System consists of four major components:

1. Quick-Disconnect Spray Head
2. Gun Head Mounting Block Assembly
3. Valve Manifold Assembly (Includes the High Voltage Cascade with a Quick-Disconnect Ring)
4. Rear Tubing Manifold Assembly (Both English and Metric)

The spray head(s) and valve manifold contain the fluid, air, and high voltage passages. All fluid passages contain stainless steel and/or nylon fittings, compatible with halogenated hydrocarbon solvents. The robot manifold incorporates stainless steel fluid connections.

The high voltage cascade is entirely encapsulated with a solvent resistant epoxy. This cascade generates voltages up to 100 kV fed by a low voltage cable.

### NOTE

- The Evolver Gun assemblies are **NOT** FM approved when used with any other power source.

There are two sources for the high voltage supply to the Evolver guns:

- Stand-alone control/power supply unit (A10406)
- MicroPak™ control unit (LECU5004-31)

The MicroPak power supply control unit provides a low voltage signal through the robot manifold to the spray gun. The high voltage cascade located within the gun converts the low voltage DC signal to a high voltage electrostatic output. (See the most current "MicroPak" and "Stand-Alone Evolver MicroPak Controller" Service Manuals for details of the control unit.)

## SPECIFICATIONS

### Environmental/Physical

**Robot/Mounting Compatibility:**  
All hollow wrist robots

**Gun Control Unit:**  
MicroPak Control Unit - LECU5004-31  
Stand-Alone Control Unit - A10406

**Operating Temperature Range:**  
55°F (12.8°C) - 131°F (55°C)

#### Weight

<b>Single-Headed:</b>	
60°	9.9 lbs. (4.5 Kg)
90°	9.6 lbs. (4.4 Kg)
<b>Dual-Headed:</b>	
60°	10.4 lbs. (4.7 Kg)
90°	10.4 lbs. (4.7 Kg)
<b>Manifold:</b>	
79175-XX	1.7 lbs. (.77 Kg) (No tubing or cable)

#### Length

<b>Single-Headed:</b>	
60°	17" (43.18cm)
90°	14 1/2" (36.83 cm)
<b>Dual-Headed:</b>	
60°	16-1/4" (41.28cm)
90°	13" (33.02cm)

<b>Tubing Manifolds (English):</b>	
79156-01	25 ft.
79156-02	50 ft.
79156-03	75 ft.
79156-04	100 ft.

<b>Tubing Manifolds (Metric):</b>	
A10853-01	7.62m
A10853-02	15.24m
A10853-03	22.86m
A10853-04	30.48m

### Electrical Requirements

**Output Voltage:** 30-100 kV

**Output Range:** 0-85 µA

**Paint Flow Rate:**  
Variable to 1500 cc/min. (Depending on viscosity & configuration)

**Trigger Response Time:** 150m sec. Open  
220m sec. Closed

#### Operating Air Pressures

**Atomizing Air:** 100 psig (6.9 bar) max.

**Fan Air:** 100 psig (6.9 bar) max.

**Trigger Air:** 70 psig min./100 psig (4.8 - 6.9 bar) max.

**Regulator Pilot:** 0 psig min./100 psig (0 - 6.9 bar) max.

**Dump Pilot:** 70 psig min./100 psig max. (4.8 - 6.9 bar)

**Operating Fluid Pressure:** 200 psig (13.8 bar) max.  
100 psig (6.9 bar) max.  
Regulated (with on-board regulator)

#### Robot Manifold Tubing Requirements

	English	Metric
Atomizing Air	3/8"	10mm OD Nylon
Fan Air	3/8"	10mm OD Nylon
Trigger Air	3/16"	4mm OD Nylon
Regulator Pilot	3/16"	4mm OD Nylon
Dump Pilot	3/16"	4mm OD Nylon
Fluid:		
Polyethylene	1/4" or 3/16" ID (Shielded & Non-Shielded)	
Teflon	1/4" or 3/16" ID (Shielded & Non-Shielded)	6mm (Non-Shielded)
Dump:		
Teflon	3/16" ID	6mm

<b>EVOLVER GUN SELECTION GUIDE</b>	
79190 -	<b>A</b> <b>B</b> <b>C</b> <b>D</b> <b>E</b> <b>FF</b> <b>G</b>
<p><b>Table A = Atomization Technology</b></p> <p>0 = Air Spray 1 = HVLP</p> <p><b>Table B = Spray Head Configuration</b></p> <p>0 = 60° Single Head 1 = 90° Single Head 2 = 60° Dual Head 3 = 90° Dual Head</p> <p><b>Table C = Purge/Regulator Configuration</b></p> <p>0 = Single Purge / No Regulator 1 = Dual Purge / No Regulator 2 = Single Purge / With Fluid Regulator 3 = Dual Purge / With Fluid Regulator 4 = Single Purge / No Regulator / Non-Electrostatic 5 = Dual Purge / No Regulator / Non-Electrostatic 6 = Single Supply / No Valves / Short Fluid Tube</p> <p><b>Table D = Robot Adapter Plate</b></p> <p>0 = No Adapter 1 = ABB 2 = Fanuc P-155 3 = Fanuc P-200 4 = Adapter (KAWASAKI-KE610L) 5 = Adapter (MOTOMAN-PX2850) 6 = Adapter (MOTOMAN-PX2900)</p> <p><b>Table E = Fluid Hose Type</b></p> <p>0 = No Fluid Hose 1 = 3/16" ID Non-Shielded 2 = 3/16" ID Shielded 3 = 1/4" ID Non-Shielded 4 = 1/4" ID Shielded 5 = 6 mm ID Non-Shielded</p>	

(Continued on next page)

**EVOLVER GUN SELECTION GUIDE (Cont.)**

79190 - A B C D E FF G

**Table FF = Cable & Tubing Manifold Configuration**

- 00 = Gun Only (No cable or manifold)
- 23 = No Cable (English tubing manifold)
- 24 = No Cable (Metric tubing manifold)

**For Use W/Power Supply Configuration 3 or 4:**

<u>English</u>	<u>Metric</u>
01 = 25' Cable (one-piece cable)	12 = 7.6m Cable (one-piece cable)
02 = 50' Cable (one-piece cable)	13 = 15.2m Cable (one-piece cable)
03 = 75' Cable (one-piece cable)	14 = 22.9m Cable (one-piece cable)
04 = 100' Cable (one-piece cable)	15 = 30.5m Cable (one-piece cable)
05 = 15' Cable to Junction Box; 15' Cable to Robot	16 = 4.6m Robot to Junction Box; 4.6m Cable to Robot
06 = 40' Cable to Junction Box; 15' Cable to Robot	17 = 12.2m Cable to Junction Box; 4.6m Cable to Robot
07 = 60' Cable to Junction Box; 15' Cable to Robot	18 = 18.3m Cable to Junction Box; 4.6m Cable to Robot
08 = 75' Cable to Junction Box; 15' Cable to Robot	19 = 22.9m Cable to Junction Box; 4.6m Cable to Robot
09 = 25' Cable to Junction Box; 25' Cable to Robot	20 = 7.6m Cable to Junction Box; 7.6m Cable to Robot
10 = 50' Cable to Junction Box; 25' Cable to Robot	21 = 15.2m Cable to Junction Box; 7.6m Cable to Robot
11 = 75' Cable to Junction Box; 25' Cable to Robot	22 = 22.9m Cable to Junction Box; 7.6m Cable to Robot

**For Use W/Power Supply Configuration 1 or 2:**

<u>English</u>	<u>Metric</u>
31 = 25' Cable (one-piece cable)	51 = 7.6m Cable (one-piece cable)
32 = 50' Cable (one-piece cable)	52 = 15.2m Cable (one-piece cable)
33 = 75' Cable (one-piece cable)	53 = 22.9m Cable (one-piece cable)
34 = 100' Cable (one-piece cable)	54 = 30.5m Cable (one-piece cable)
35 = 15' Cable to Junction Box; 15' Cable to Robot	55 = 4.6m Cable to Junction Box; 4.6m Cable to Robot
36 = 40' Cable to Junction Box; 15' Cable to Robot	56 = 12.2m Cable to Junction Box; 4.6m Cable to Robot
37 = 60' Cable to Junction Box; 15' Cable to Robot	57 = 18.3m Cable to Junction Box; 4.6m Cable to Robot
38 = 75' Cable to Junction Box; 15' Cable to Robot	58 = 22.9m Cable to Junction Box; 4.6m Cable to Robot
39 = 25' Cable to Junction Box; 25' Cable to Robot	59 = 7.6m Cable to Junction Box; 7.6m Cable to Robot
40 = 50' Cable to Junction Box; 25' Cable to Robot	60 = 15.2m Cable to Junction Box; 7.6m Cable to Robot
41 = 75' Cable to Junction Box; 25' Cable to Robot	61 = 22.9m Cable to Junction Box; 7.6m Cable to Robot

**Table G = Power Supply Configuration**

- 0 = No Power Supply
- 1 = A10406-01 Power Supply Enclosure with one MicroPak and one Discreet I/O Card
- 2 = A10406-01 Power Supply Enclosure with two MicroPaks and two Discreet I/O Cards
- 3 = One LECU5004-31 MicroPak (FM Approved)
- 4 = One LECU5004-11 MicroPak (Not FM Approved)

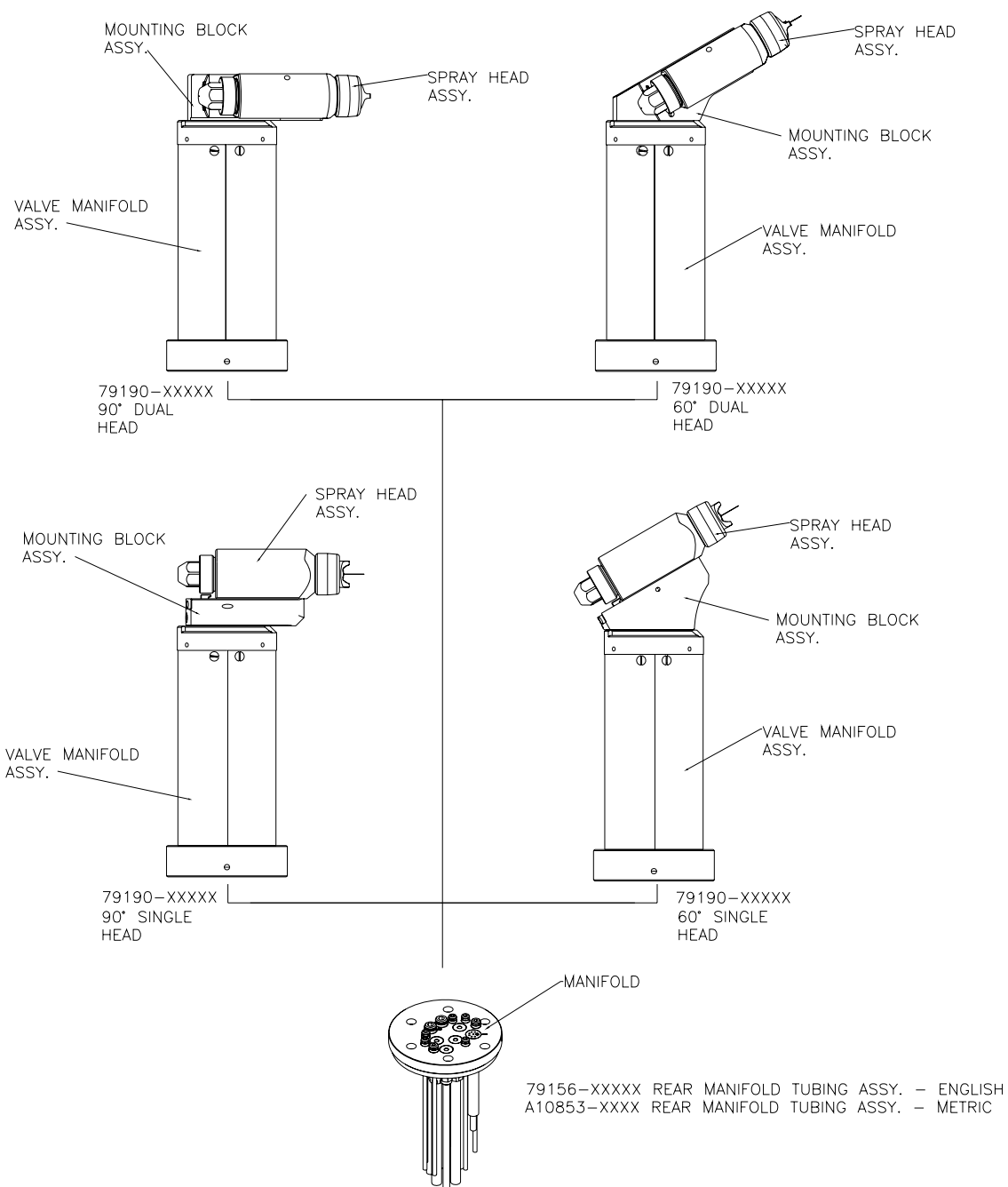

Figure 1: Evolver Solventborne Robotic Atomizer Guns



## FEATURES

The features of the Evolver series guns include:

- Quick-disconnect spray head
- High quality ITW Ransburg air cap and fluid nozzle
- True "dual purge function"
- Dual fluid supply passages
- Dual fluid dump valves are located adjacent to the fluid passages
- Internal fluid regulator
- Field proven high voltage system
- Dual start, dual pitch air cap retaining ring
- Quick-disconnect robot mount plate
- Quick color change capability with integrated solvent valve
- Clean interior design with split shroud
- Internal fan and atomization air control valve, with a mechanically timed trigger sequence
- Color coded air and trigger actuation lines

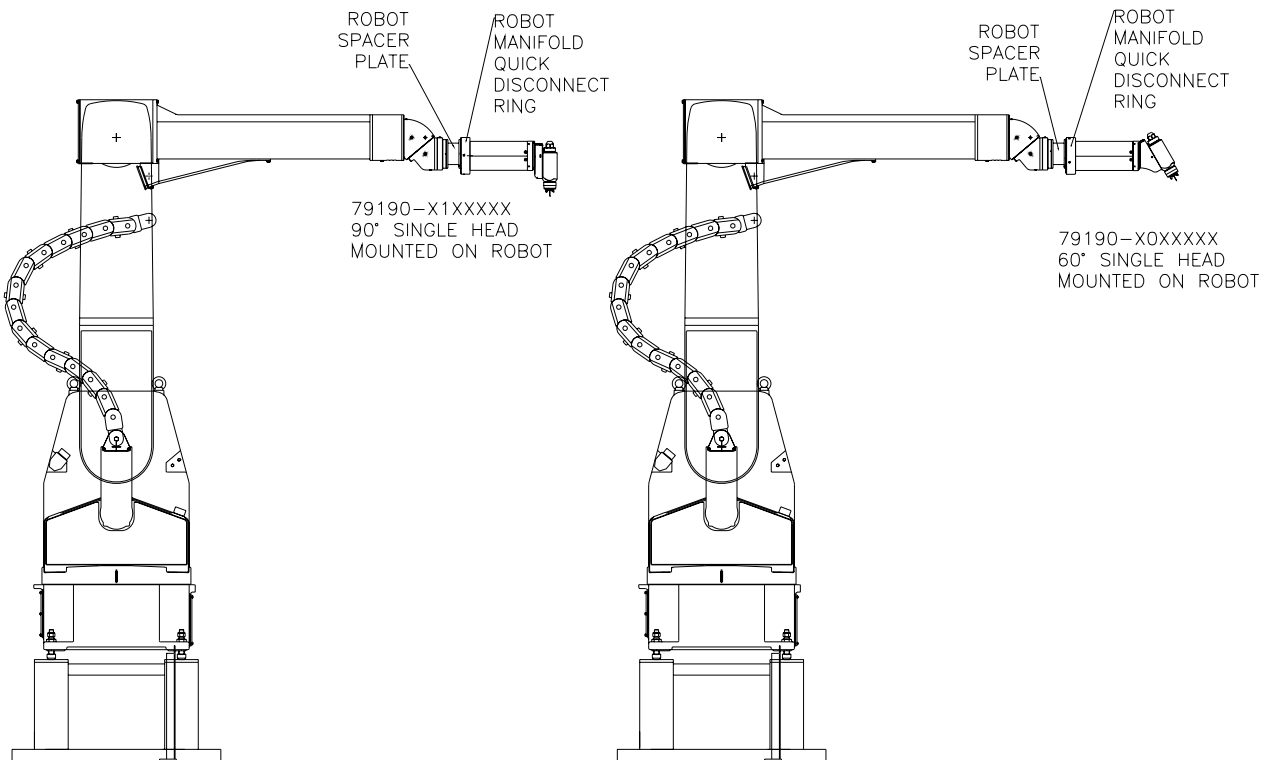

Figure 2: Typical Robotic Applicator Mounting

# 79190-XXXXXXX EVOLVER GUN ASSEMBLY

The gun assembly is designed to connect to hollow wrist robots. A low voltage control cable is supplied with the gun to connect the cascade to the MicroPak power supply.

The "Paint In" lines come in both 3/16" ID and 1/4" ID shielded or non-shielded.

## Tool Center-Point

Figure 3 shows the tool center-point information for the four guns. They are all based upon a 10" (245mm) target distance.

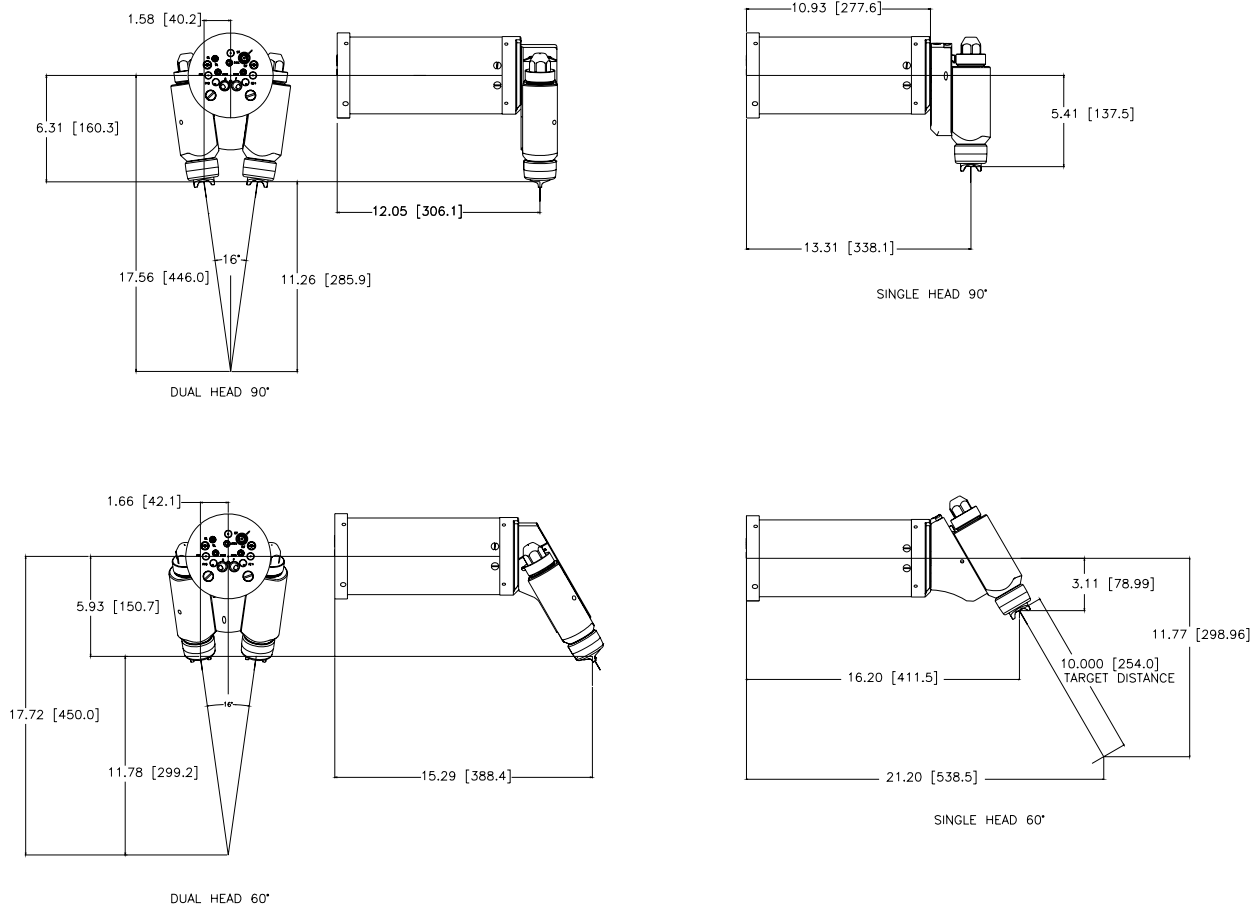

Figure 3: Tool Center-Point

**NOTES**

---

# INSTALLATION

---

## EVOLVER ROBOTIC ATOMIZER INSTALLATION

This information is intended **ONLY** to indicate the general installation parameters of this product and, where applicable, its working relationship to other ITW Ransburg system components in typical use. Each installation is unique and should be directed by an authorized ITW Ransburg representative or conducted from the ITW Ransburg installation drawings provided for your particular installation.

## POWER SUPPLY ASSEMBLY

Refer to the most current Power Supply Unit manuals for complete information regarding power supply installation.

### **WARNING**

- ▶ The power supply **MUST** be located outside the **HAZARDOUS** area (Reference OSHA, NFPA-33, and your insurance company requirements.)
- ▶ User should be aware of, and adhere to, all local fire codes and ordinances.
- ▶ The user **MUST** provide a properly fused disconnect between the power source and the power supply which complies with appropriate codes.
- ▶ Fluid supply must be grounded per NFPA-33.

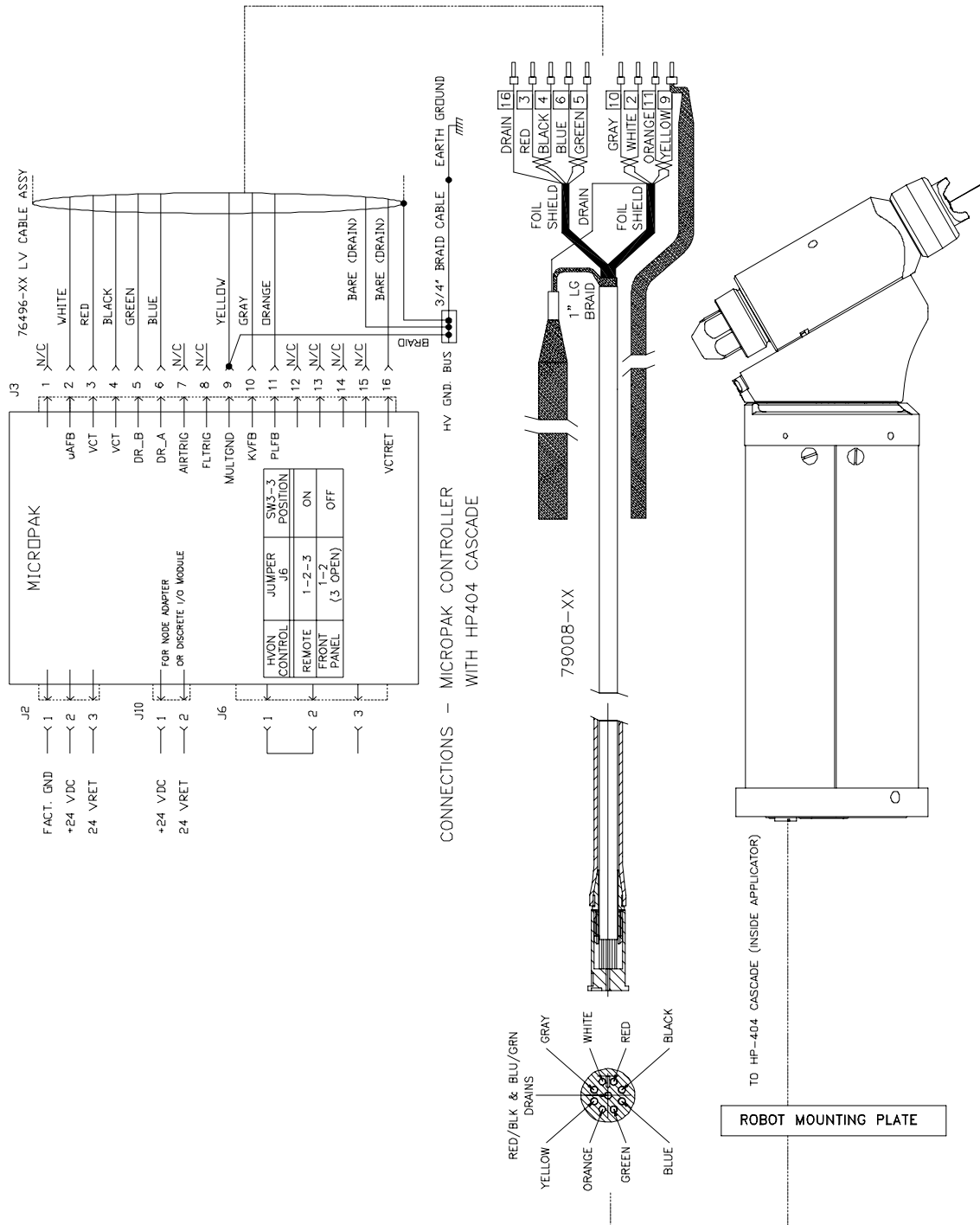

**Figure 4: Low Voltage Cable Connections**

# GUN AND MANIFOLD ASSEMBLY

(See Figures 4 and 5)

The tubing, hose, and low voltage cable come bundled from the factory. Pull the bundle through the robot spacer plate and robot wrist carefully to prevent any cuts on the cable or hoses. Use the six (6) socket head cap screws (7959-32C) included with the rear manifold tubing assembly to attach the rear manifold assembly (79156) to the robot spacer plate (see Table 1).

Connect each signal line as required per signal legend for both English and Metric tubing bundles, table following.

## Robot Spacer Plate

The robot spacer plate is included with the robot manifold assembly to increase life of the tubing bundle. The extra spacing it provides, increases the bend radius of the tubes and decreases the hose or cable stress at the connector.

There is only one way the spacer plate may be assembled to the mounting plate. The spacer plate has an alignment pin that may only engage in one hole position in the robot mount plate. This provides the final position to top dead center of the robot.

The six (6) robot spacer plates, Table 1, are available for this product.

TABLE 1 - SPACER PLATES	
Part #	Description
79107-00	ABB Robots
78983-00	Fanuc P155, 145 Robots
79131-00	Fanuc P200 Robot
A10847-00	Adapter (Kawasaki-KE610L)
A10848-00	Adapter (Motoman-PX2850)
A10849-00	Adapter (Motoman-PX2900)

For installations utilizing the LECU5004-XX MicroPak Power Supply, connect the low voltage cable (79008-XX) from the robot manifold assembly to the LECU5004-XX MicroPak Controller or junction box. If connecting to a junction box, use a junction cable (77062-XX) to make the connection from the junction box to the LECU5004-XX MicroPak. Make connections as shown in Figure 4.

For installations utilizing the A10406-XX Evolver MicroPak Power Supply, connect the low voltage cable (A11353-XX or A11356-XX) from the robot manifold assembly or junction box to the receptacle on the rear of the A10406-XX power supply. To maintain FM Approval, this cable must be secured to the stress relief bar on the rear of the power supply. (See "A10406-XX Evolver MicroPak Power Supply" manual for further information on connecting the low voltage cable.)

**CAUTION**

▶ Leave 12-24 inches of extra length on all lines to prevent extreme tension being applied to these lines during robot movement.

**CAUTION**

▶ Do not exceed 100' combined length of the low voltage cables.

**WARNING**

▶ Install and route the hoses and cable so that they are **NOT** exposed to temperatures in excess of 120° F. Ensure that all hose and cable bends are **NOT LESS THAN** a 6 inch (15cm) radius and are not subjected to more than 360° of torsional twist. Failure to comply with these parameters could cause equipment malfunctions that might create **HAZARDOUS CONDITIONS!**

**WARNING**

▶ If a non-explosion proof junction box/terminal strip is used, it must be located outside the hazardous area.

<b>SIGNAL IDENTIFICATION TABLE - ENGLISH</b>					
<b>Abbr.</b>	<b>Description</b>	<b>Color</b>	<b>Tubing Material</b>	<b>Tubing Size</b>	<b>Item #</b>
P1	Paint #1	Clear	Teflon	5/16" OD X 3/16" ID	29
P2	Paint #2	Black	Urethane/Poly/Teflon	5/16" OD X 3/16" ID	29
P1	Paint #1	Clear	Teflon	3/8" OD X 1/4" ID	29
P2	Paint #2	Black	Urethane/Poly/Teflon	3/8" OD X 1/4" ID	29
SOL	Solvent	Black	Urethane/Poly	3/8" OD X .187" ID	28
P1T	Paint #1 Trigger	Green	Nylon	3/16" OD X .050" Wall	24
P1D	Paint #1 Dimp	Gray	Nylon	3/16" OD X .050" Wall	25
P2T	Paint #2 Trigger	Natural	Nylon	3/16" OD X .050" Wall	17
P2D	Paint #2 Dump	Black	Nylon	3/16" OD X .050" Wall	31
TP	Trigger Pilot	Black	Nylon	3/16" OD X .050" Wall	27
DL	Dump Line	Natural	Teflon	.313" OD X .188" ID	19
RP	Regulator Pilot	Natural	Nylon	3/16" OD X .050" Wall	17
ST	Solvent Trigger	Blue	Nylon	3/16" OD. X .050" Wall	26
F	Fan Air	Black	Nylon	3/8" OD X .250" ID	23
A	Atomization Air	Natural	Nylon	3/8" OD X .250" ID	16
LV	Low Voltage Cable	Black	N/A	N/A	2

<b>SIGNAL IDENTIFICATION TABLE - METRIC</b>					
<b>Abbr.</b>	<b>Description</b>	<b>Color</b>	<b>Tubing Material</b>	<b>Tubing Size</b>	<b>Item #</b>
P1	Paint #1	Clear	Teflon	8mm OD X 6mm ID	29
P2	Paint #2	Clear	Teflon	8mm OD X 6mm ID	29
SOL	Solvent	Clear	Teflon	8mm OD X 6mm ID	29
P1T	Paint #1 Trigger	Green	Nylon	4mm OD X .106" ID	24
P1D	Paint #1 Dimp	Silver	Nylon	4mm OD X .106" ID	25
P2T	Paint #2 Trigger	Natural	Nylon	4mm OD X .106" ID	17
P2D	Paint #2 Dump	Black	Nylon	4mm OD X .106" ID	31
TP	Trigger Pilot	Yellow	Nylon	4mm OD X .106" ID	27
DL	Dump Line	Clear	Teflon	8mm OD X 6mm ID	29
RP	Regulator Pilot	Natural	Nylon	4mm OD X .106" ID	17
ST	Solvent Trigger	Blue	Nylon	4mm OD X .106" ID	26
F	Fan Air	Black	Nylon	10mm OD X 8mm ID	23
A	Atomization Air	Natural	Nylon	10mm OD X 8mm ID	16
LV	Low Voltage Cable	Black	N/A	N/A	2

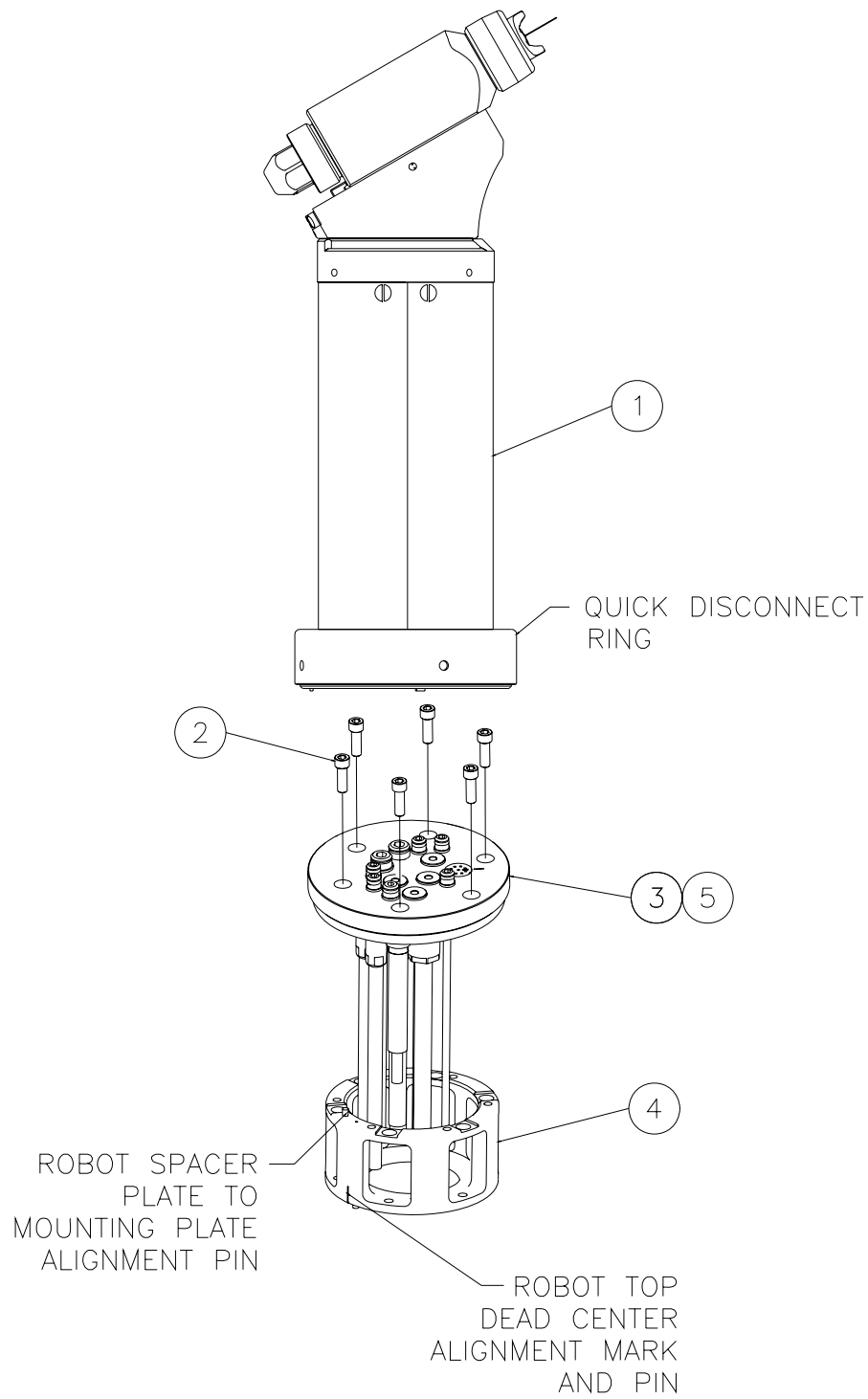

**Figure 5: Gun and Manifold Assembly**



<b>GUN AND MANIFOLD ASSEMBLY - PARTS LIST (Figure 5)</b>			
<b>Item #</b>	<b>Part #</b>	<b>Description</b>	<b>Qty</b>
1	79190-XXXXXXXX	Evolver Spray Gun	1
2	76566-32C	Socket Head Cap Screws, 1/4-20 X 1" Long, Stainless Steel	6
3	79156-XXXX	Rear Manifold Tubing Assembly (English)	1
4	<b>See Table 1</b>	Spacer Plates	1
5	A10853-XXXX	Rear Manifold Tubing Assembly (Metric)	1

# OPERATION

## SPRAY GUN CONTROLS

### Atom (A) / Fan Air (F)

The atomization and fan air are turned on by the trigger line and are controlled by an internal air valve located in the gun head. During normal operation with gun triggered off, there is a slight bleed of air through the atomization part.

### Atomizing Air

Adjustments are made through the robot PLC or a manually adjustable air regulator. The lowest air pressure required to break up the paint should be used. Lower atomizing air pressures result in less overspray and increased transfer efficiency.

### Fan Air

Adjusting the fan air increases or decreases the size of the spray pattern. Increasing pressure increases pattern size. Pattern adjustment should be made to suit the size and shape of the object being painted. This adjustment is made through the robot PLC or a manually adjustable air regulator.

Air cap pressures should be set using air cap test kit. This provides a consistent measurement, so initial settings may be duplicated at any time. (See "Parts Identification" section for "Air Cap Test Kit part numbers".)

**NOTE**

- ▶ Insure that the fan and atomization air are on and flowing prior to triggering the fluid. Failure to follow this sequence will cause spits and defects on the part being painted.

## HVLP SPRAY

The Evolver HVLP models, when properly set-up, are designed to provide maximum transfer efficiency by limiting air cap pressures to 10 psi (0.7 bar) (in the U.S., this complies with rules issued by SCAQMD and other air quality authorities). Air cap pressures should be measured with an optional air cap test kit. (See "Accessories" in the "Maintenance" section.)

**NOTE**

- ▶ For HVLP operation (max. 10 psi, -0.7 bar cap pressure), **DO NOT** exceed the air inlet pressure, which was read at the gun base before the tubing manifolds, given as follows:

PSI	(Bar)	CAP #
42	(2.9)	48-1
42	(2.9)	481-1

## BACK PRESSURE - 48-1 and 481-1

Due to the unique cone shape of the MP fluid tips (nozzle), a slight back pressure is created against the fluid column. This will reduce the amount of fluid output. To compensate, increase the fluid regulator pressure slightly if necessary. With 10 psi (0.7 bar) cap pressure, back pressures are approximately 3.5 psi (0.24 bar).

## FLUID VALVE CONTROLS

### Trigger, Dump, & Solvent (See Figure 6)

The fluid valves in the Evolver are actuated by an air signal. The air pressure must exceed 70 psi (4.83 bar) to assure proper actuation of the valve. Applying air to the valve actuator turns on the fluid flow for that valve.

The trigger valve controls the paint flow to the gun. When actuated, paint flows through the valve to the fluid tube and into the spray head.

The dump valve controls the paint flow through the dump line. When actuated, paint flow is direct to the dump return line. This provides a method of rapidly removing paint from the incoming line for cleaning and/or color change. Normally, the dump valve is not actuated at the same time as the paint trigger valve since the trigger valve is intended to cause the fluid to flow to the gun at the prescribed input pressure.

The solvent valve controls the flow of cleaning solvent to the gun. When actuated, solvent flows through the fluid tube and into the spray head. The solvent valve is not triggered at the same time as the paint trigger valve to prevent solvent from flowing backward into the paint line.

## DUAL PURGE SPRAYING

The Evolver has optional dual purge capability. This means the applicator can continue to spray paint, at voltage, while side "B" or "Paint 2" is being flushed or cleaned. To operate in the dual purge mode, **two (2) separate color valve systems must be installed.**

When the target part is finished and a color change is desired, insure voltage is turned off.

The solvent valve controls the flow of cleaning solvent to the gun. When actuated, solvent flows through the fluid tube and into the spray head. The solvent valve is not triggered at the same time as the paint trigger valve to prevent solvent from flowing backward into the paint line.

**WARNING**

► Failure to turn voltage OFF during color change sequence could cause a fire or explosion.

When the cleaning cycle with solvent is complete, an air purge for several seconds is recommended to clean and dry the ID of the dump line hose.

### Paint Viscosity

The applicator is capable of atomizing paint of most any desired viscosity. It is recommended to keep the material viscosity as low as possible. This allows spraying at lower fan and atomization air pressures which results in less overspray and higher transfer efficiency.

**WARNING**

► Most paints and solvents, including those listed in Figure 7, are toxic to a certain degree and flammable or combustible. Use them only in a well ventilated atmosphere. Use protective equipment as required in the Material Safety Data Sheet supplied with the substance.

### Fluid Flow Rate

Fluid flow is adjusted through the robot PLC by varying the pilot pressure to either an exterior or the on-board fluid regulator within the spray gun. Fluid pressures from the circulating system may exceed the maximum fluid pressure rating of the Evolver gun. Because of these high fluid pressures, a manual step-down fluid regulator must be used.

### Trigger Control Air

The Evolver guns require a minimum of 70 psig trigger control air pressure to ensure proper operation of the gun piston.

### Electrostatic Voltage

Under no load conditions, the maximum voltage limit for these spray guns is 100 kV. Some painting operations may require different voltage settings to obtain optimum transfer efficiencies. If Faraday cage areas are predominant on the item being painted, a lower voltage setting would aid in coating these areas.

When not spraying, it is recommended to set back voltage to 30-40 kV or off between target parts.

#### NOTE

- ▶ If a 0 kV command is sent to the MicroPak, a feedback fault will occur.

Sometimes, depending upon target carrier spacing, higher setback voltages may be required. The ramp-up time for the HP-404 cascade (0-100 kV) is approximately 3 seconds.

The MicroPak voltage ramp-down works at a rate of 33 kV/sec.

### Target Distance

The distance between the gun tip and the article being painted should be 10-14 inches. Excessive distance causes a waste of coating material and wrap back (paint particles being deposited on the gun body or the robot arm). At close distances the voltage at the tip of the gun will be reduced, which decreases the charging effect of the gun.



#### WARNING

- ▶ If target distance is less than 8 inches, an arc could occur.

## NOTES

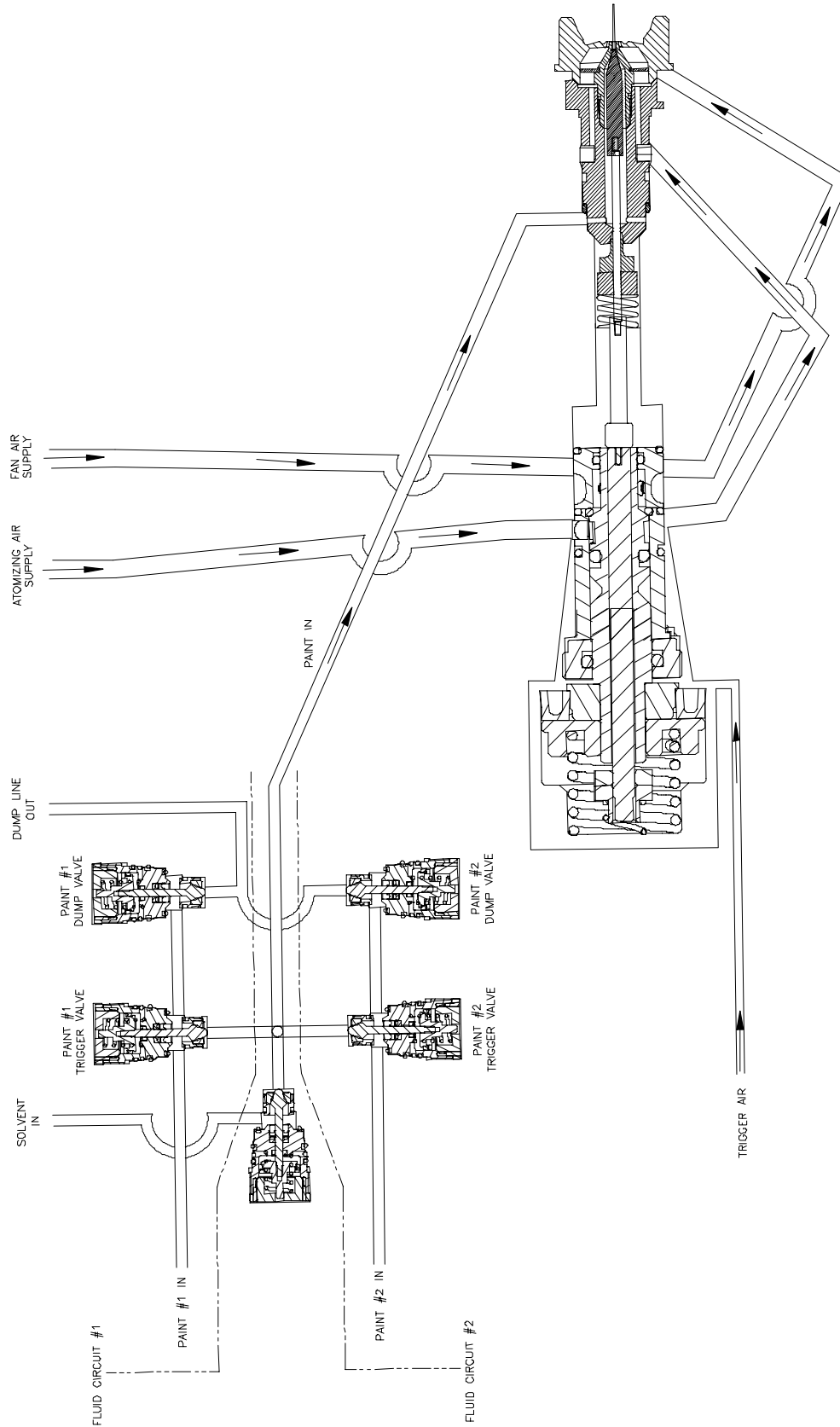

**Figure 6: Simplified Air and Fluid Flow Passage Layout**

# MAINTENANCE

Good maintenance is essential to safe and productive operation. Schedules should be established by the user, based on the following general information and observations of the initial production requirements. The ITW Ransburg maintenance and safety information should be made available to each operator.

Normal fire protection measures are necessary, including proper storage of paints and solvents and the proper disposal of waste. Ready access to appropriate fire extinguishing equipment is required. For details, consult the appropriate NFPA safety information, your local fire codes, and local painting equipment standards. Reference OSHA, NFPA-33, and your insurance company information.

**WARNING**

- ▶ An electrical discharge or spark may create an electrical and/or fire hazard during maintenance. Do not clean or service the spray gun with the power supply on. Verify that the power supply has been locked out and tagged out per OSHA.
- ▶ Unexpected robot movement can be hazardous. Do not adjust or repair the spray gun when the robot is operating or waiting to start. The robot must be locked out and tagged out per OSHA.
- ▶ Solvents used for equipment flushing must have flash point ratings equal to or greater than the flash point rating of the coating material. Solvents used for general cleaning must have flash point ratings higher than 100°F (37.8°C).
- ▶ Never remove spray gun head from assembly while under pressure.

## ROUTINE MAINTENANCE SCHEDULE

Follow these maintenance steps to extend the life of the gun and ensure efficient operation:

### Several Times Daily

1. Turn the MicroPak Control Unit **OFF!** Follow Lockout/Tagout procedures.
2. Inspect the fluid nozzle and electrode wire for paint accumulation. Clean as frequently as necessary. See "Procedures" in the "Maintenance" section.

**WARNING**

- ▶ Take precautions to see that skin is not punctured by sharp electrode.

**CAUTION**

- ▶ Do not bend the gun electrode while wiping. Never immerse the gun in solvents. This will cause damage to the electrical components.

### Daily (Or at Shift Start)

1. Turn the MicroPak Control Unit **OFF** and:
  - Check within 20' (6.1 meters) of the point of operation (of the gun) and remove or ground **ALL** loose or ungrounded containers.
  - Inspect workholders for accumulated coating materials (remove such accumulations if present).
  - Check that the nozzle assembly is clean and undamaged.

2. Turn the MicroPak Control Unit **ON!** Energize high voltage.

**Shut-Down (Or at Shift End)**

1. Turn the MicroPak Control Unit OFF.
2. Flush the lines and allow the solvent to remain in the lines. See "Procedures" in the "Maintenance" section.
3. Wipe the gun and robot wrist with a cloth and a suitable, clean non-polar solvent.

**Weekly**

1. Check the entire system for damage, leaks and paint accumulation.
2. Clean the atomizer assembly.
3. Conduct a current output test. See "Procedures" in the "Maintenance" section.

**PROCEDURES**

**Gun Cleaning/Service (See Figure 8)**

1. Flush the paint supply line and the gun paint passages using a solvent which is compatible with the material being sprayed. Continue to flush until all traces of paint are gone.
2. Turn off the solvent supply, actuate paint push-out air at color changer and trigger the gun. Allow all of the fluid to drain from the spray gun fluid passages.
3. Clean the exterior surfaces of the spray gun with a solvent soaked rag. As long as the gun is intact, a **polar** solvent may be used for all cleaning, however, after cleaning, wipe off all surfaces with a **non-polar** solvent to reduce conductive residue on the gun's surface. (See Figure 7 regarding proper solvent selection.)

	<b>CAUTION</b>
<p>► Failure to use a non-polar solvent will cause a decrease in voltage at the tip of the gun. This will significantly decrease transfer efficiency.</p>	

4. Remove end cap [1]. Removing the end cap releases tension on all internal spray head components. Remove needle spring [2] and valve spring [3], which are loose after removing the piston cap.

	<b>CAUTION</b>
<p>► Never attempt to clean the air cap holes with a wire or other metal object. Doing so may damage the air cap, resulting in distortion of the spray pattern.</p>	

5. Remove the air cap retainer [36] and air cap [35]. Soak in a non-polar solvent if necessary. If paint remains in the air cap holes, clean with a toothpick or similar soft wood object. Air caps are best cleaned in an ultrasonic cleaner.

6. Remove the air cap locator [33] and fluid tip [34]. Clean using a non-polar solvent.

7. Tightly grip the plastic needle [6] and unscrew counter-clockwise to remove the front electrode needle assembly. A short piece of H-2339 tubing (1/4" OD x 0.175" ID) pressed over the front needle will assist in unscrewing the assembly. If required, use needle nose pliers with masking tape or duct tape. Carefully clean with a non-polar solvent. Replace any parts that show signs of wear or damage.

	<b>CAUTION</b>
<p>► If using needle nose pliers to unscrew the front needle, be very careful. Do not grip on the tapered sealing surface. If the pliers slip, they could damage the tapered sealing surface of the needle.</p>	

<b>POLAR AND NON-POLAR SOLVENTS</b>		
<b>Non-Conductive (Non-Polar)</b>	<b>Moderately Conductive</b>	<b>Extremely Conductive (Polar)</b>
Amyl Acetate Methyl Amyl Acetate Toluene Xylene High Flash Naptha Mineral Spirits	Methyl Isobutyl Ketone Ethyl Acetate Methyl Ethyl Ketone Butyl Carbitol	Methanol Carbitol Diacetone Butyl Alcohol Acetone Butyl Cellosolve

**Figure 7: Polar and Non-Polar Solvents**

8. Remove fluid nozzle [32] by unscrewing counter-clockwise. Inspect o-ring [30] and all passages for build up or damage. Clean or replace as necessary. Lubricate and reinsert o-ring into gun barrel and reinstall fluid nozzle. Torque fluid nozzle to 25 lbs•in (2.82 Nm).

**NOTE**

- ▶ There should be a small gap between the fluid nozzle and the gun barrel after tightening.

9. After cleaning, insert the electrode assembly [31] back into the spray head assembly. Apply Loctite #222, low strength (purple) thread-locker, to the threads of the electrode assembly before reassembly.

**NOTE**

- ▶ The fluid tip [34] should always be installed and tightened before installing the needle and valve springs.

<b>CAUTION</b>
▶ After tightening the fluid tip, always check to see if the proper gap (1/16") between the needle nuts and air valve stem occur, before installing the needle and valve springs back into the head.

10. Screw fluid tip [34] back into place. Hand tighten first, then with a small wrench, tighten an additional 30 degrees.

11. Replace air cap locator [33], air cap [35], and air cap retainer [36].

12. Apply a thin film of petroleum jelly to valve and needle springs [2] and [3]. Install the springs back into the end cap and the spray head assembly.

13. Screw end cap [1] back on.

**Current Output Test**

1. Clean and blow out all fluid passages with non-conductive solvent.

2. Remove from robot and perform bench test using a spare tubing bundle.

3. Turn the control unit power **ON**.

4. Activate high voltage and slowly approach the gun electrode with ground hook or wire.

5. Monitor the current output on the MicroPak. Current should rise as ground approaches. At approximately 85 microamperes, the MicroPak will shut off. The **OVERCURRENT** indicator should come on.

The spray head can be removed from assembly as shown in Figure 8 for cleaning and service.



**NOTES**

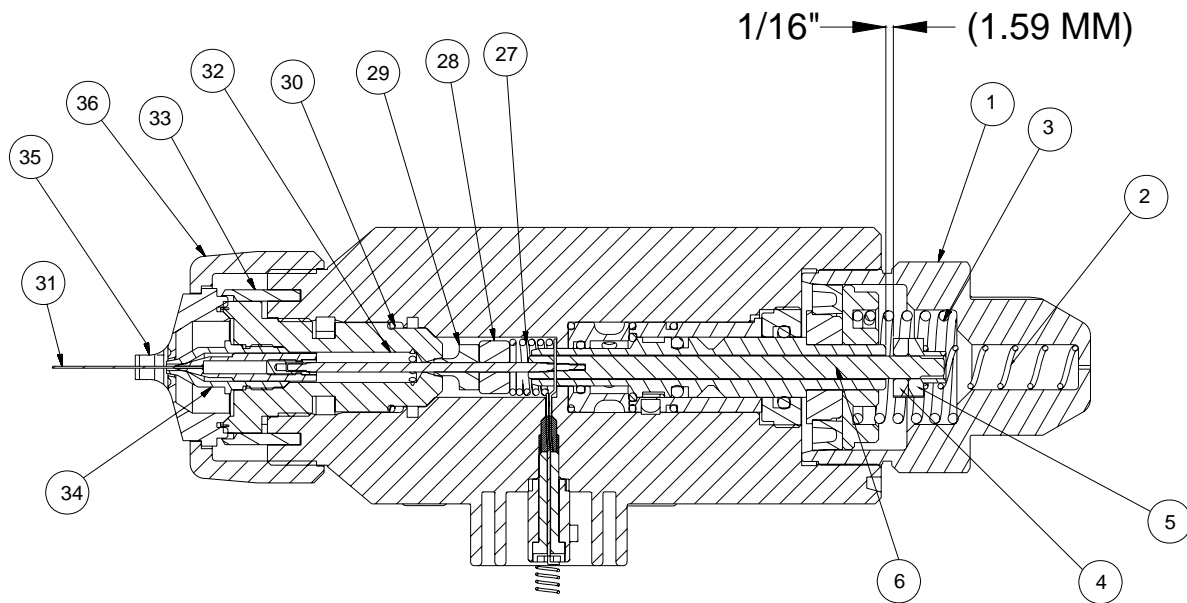
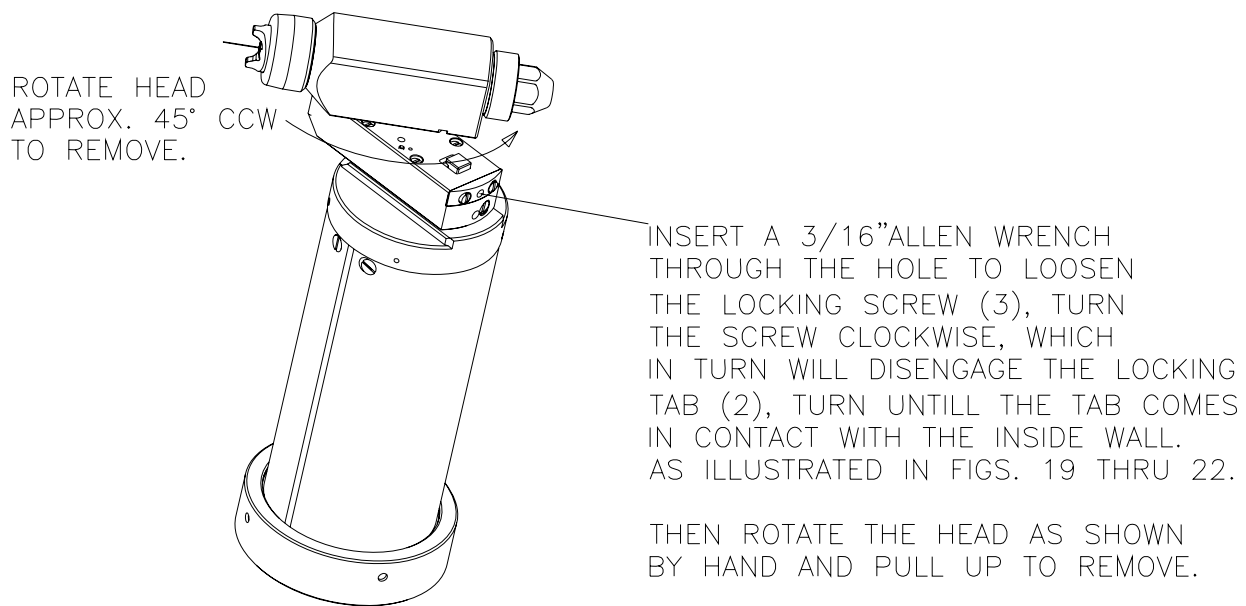

Figure 8: Spray Head Removal Assembly

<b>SPRAY HEAD REMOVAL ASSEMBLY - PARTS LIST (Figure 8)</b>			
<b>Item #</b>	<b>Part #</b>	<b>Description</b>	<b>Qty</b>
1	79148-00	End Cap, Spray Head	1
2	17615-00	Spring, Compression	1
3	9334-00	Spring, Valve Return	1
4	7733-07	Jam Nut	1
5	76199-00	Rear Adjusting Nut	1
6	79151-00	Assembly, Needle Shaft	1
27	RME-38	Return Spring, Piston	1
28	EMF-7	Seal, Washer	1
29	RME-32	Seal	1
30	79001-01	O-Ring, Solvent Proof	1
31	70430-01	Electrode, High Wear	1
32	EMF-195	Nozzle, Fluid Hole	1
33	EMF-192	Locator, Air Cap	1
34	79140-02	Fluid Tip, .055 (1.4mm) Diameter	1
35	79153-65R-1	Air Cap, Pined	1
36	79154-00	Retaining Ring, Tapered	1

## SERVICE

Because we want to provide our users with the most up-to-date technology possible, we are constantly seeking to improve products. If a change in product configuration occurs after it is on the market, we will implement that technology in future production and, if practical, make it available to current users. The following service information is based on standard specifications and procedures for this product. If you find some minor deviations between this information and your equipment because of design or manufacturing changes, contact your ITW Ransburg representative to resolve the difference.

**⚠ WARNING**

- ▶ An electrical discharge or spark may create an electrical and/or fire hazard during maintenance. Do not service the spray gun with the power supply on. Verify that the power supply on/off switch has been turned off.
- ▶ Unexpected robot movement can be hazardous. Do not adjust or repair the spray gun when the robot is operating or waiting to start. The robot must be locked out and tagged out per OSHA prior to removing the gun from the robot manifold assembly.

Before performing any work on the spray gun, always flush the fluid passages and blow dry with pushout air, and wipe the spray gun clean. Refer to "Gun Cleaning" in the "Maintenance" section for instructions on how to properly clean the spray gun. Depressurize all fluid and air pressures before removing the gun from its manifold. Always work in a clear, clean space to minimize parts loss and damage.

**⚠ CAUTION**

- ▶ As the spray head is removed from the valve manifold assembly, a certain amount of residual fluid may be present. Care must be taken not to allow this fluid to drain into the high voltage terminal rings or air passages.

**⚠ WARNING**

- ▶ Eye protection should be worn while servicing gun.

## SPRAY HEAD ASSEMBLY

**NOTE**

- ▶ Disassemble spray head only enough to remove and replace defective parts. For instance, if only replacing the front electrode it is not necessary to remove the fluid nozzle.

**NOTE**

- ▶ At assembly, apply a small amount of dielectric grease to grooves in spray head and valve manifold to reduce high voltage breakdown. Excessive grease will not allow spray head [2] to seat fully against mounting block assembly [3] (see Figure 10).
- ▶ To prevent damage, always lubricate the o-rings located on the underside of the spray head.

## Rear Needle Replacement (See Figure 8)

1. Remove the air cap, fluid tip, and the fluid nozzle as described in steps 1 through 8 of the "Fluid Tip, Nozzle, and Front Needle Replacement" in the "Maintenance" section.

2. Remove the rear needle [6] and lock nuts [4] and [5] as an assembly. Pull the assembly out from the rear of the spray head.

 <b>CAUTION</b>
<p>► Fluid seal [29], seal washer [28], and seal spring [27], will come free at this point. Place hand over end as not to drop parts.</p>

3. Inspect metal portion of the rear needle [6] for excessive wear. If wear is observed (longitudinal grooves or a noticeable reduction in diameter), replace the needle. Remove the two (2) lock nuts from the rear needle and save. When ever replacing rear needle section, you must also replace the seal [29] at the same time.

4. Place the rear needle assembly back into the spray head.

5. Place seal spring [27] over the rear needle in the front end of the spray head. Hold the spray head upward as the spring will want to fall out.

6. Still holding the spray head upward, place the seal washer [28] and thread the fluid seal [29] onto the rear needle. The tapered end of the fluid seal should be pointed toward the front of the gun.

7. Insert the lubricated o-ring [30] into the gun head. Gently push, with small flat object, down upon its seating edge. Be careful not to push o-rings into fluid groove (see Figure 8).

8. Reassemble fluid nozzle [32] by pushing the nozzle into the spray head and through the o-ring until the threads engage. Screw the nozzle into the spray head. Torque to 23-25 lbs•in (2.6-2.8 Nm). Plastic threads damage easily; do not over-tighten. Note the front flange of the fluid nozzle will not seat flush against the spray head.

9. Apply Loctite #222 Low Strength (purple) Threadlocker into the threads of plastic front needle [31] before assembling onto the rear needle. Be sure that the rear needle assembly is pushed all the way forward before threading on front needle.

10. Reassemble fluid tip [34]. Hand tighten first; then with a small wrench turn an additional 30°.

11. Reinstall the two (2) lock nuts [4] and [5] in the correct order on the back needle as shown making sure to maintain an 1/16" clearance (see Figure 8).

12. Reassemble air cap [35] and air cap retainer [33]. The air cap rotate positioning pins must be engaged with the air cap locator holes before final tightening.

13. Apply a thin film of petroleum jelly to valve spring [3] and needle spring [2], and insert back into the end cap. Screw end cap [1] back on.

14. Lubricate all of the o-rings on the underside of the spray head with petroleum jelly, and apply a thin coat of dielectric grease to the grooves of the spray head and the valve manifold before reassembly.

15. Reattach spray head to manifold block by engaging the connection plug [24] into the mounting block cavity [3], and turn clockwise until head contacts stop pin on the block.

## Air Valve Removal (See Figure 9)

1. After removal of end cap and spring, the air valve can be pulled straight out the back of the head assembly.

2. Inspect and replace the u-cup [8], if necessary, by holding the air valve shaft on it's flats and loosening the piston nut [7] counter-clockwise.

3. Remove the seal carrier with seal removal tool [B].

4. Use a bent hook to reach inside the air valve bushing [14], grip slot and pull out. Use the same procedure to pull out the rear seal carrier [17].

**CAUTION**

► Use Caution as **NOT TO** scratch or raise burrs on inside diameters of the parts.

5. Remove and replace all o-rings if necessary.
6. O-rings [12] and [18] must be installed inside their mating parts (see Figure 9).
7. The Teflon o-ring [16] should be inserted into the front of the bushing [14] and one of the o-rings [15] installed onto the outside groove before the bushing is installed.
8. Reassemble the remaining parts, as shown in Figure 9, making sure that the alignment tab on the bushing [14] lines up with the align groove in the body [19].
9. Torque the seal carriage [13] to 30-35 lbs•in (4.0-4.5 Nm).
10. If the u-cup needs to be replaced, assemble on piston plate [9] and push both onto shaft, tighten securely with piston nut [7], and install in body as one assembly.
11. Assemble the remainder of the gun head as stated earlier.
12. If the locking tab plug connection [24] needs to be replaced, first remove the electrode spring connector [23] by pulling straight out with a needle nose pliers. If removed, the spring wire should be replaced.
13. Remove socket head screw [22] and connection plug [24] from body.
14. Replace conductive compressable contact [25] if necessary.
15. Reinstall the connection plug [24] into the body, making sure the tabs on the bottom align with the notches in the body [19].
16. Insert and tighten the screw [22], making sure the tabs remain inside the notches [24] in the body.
17. Insert the spring electrode wire [23] through the hole in the screw using a needle nose pliers on the straight wire portion. Carefully rotate and push the wire through the screw hole and into the compressable contact until the spring contacts the screw head.

**NOTES**

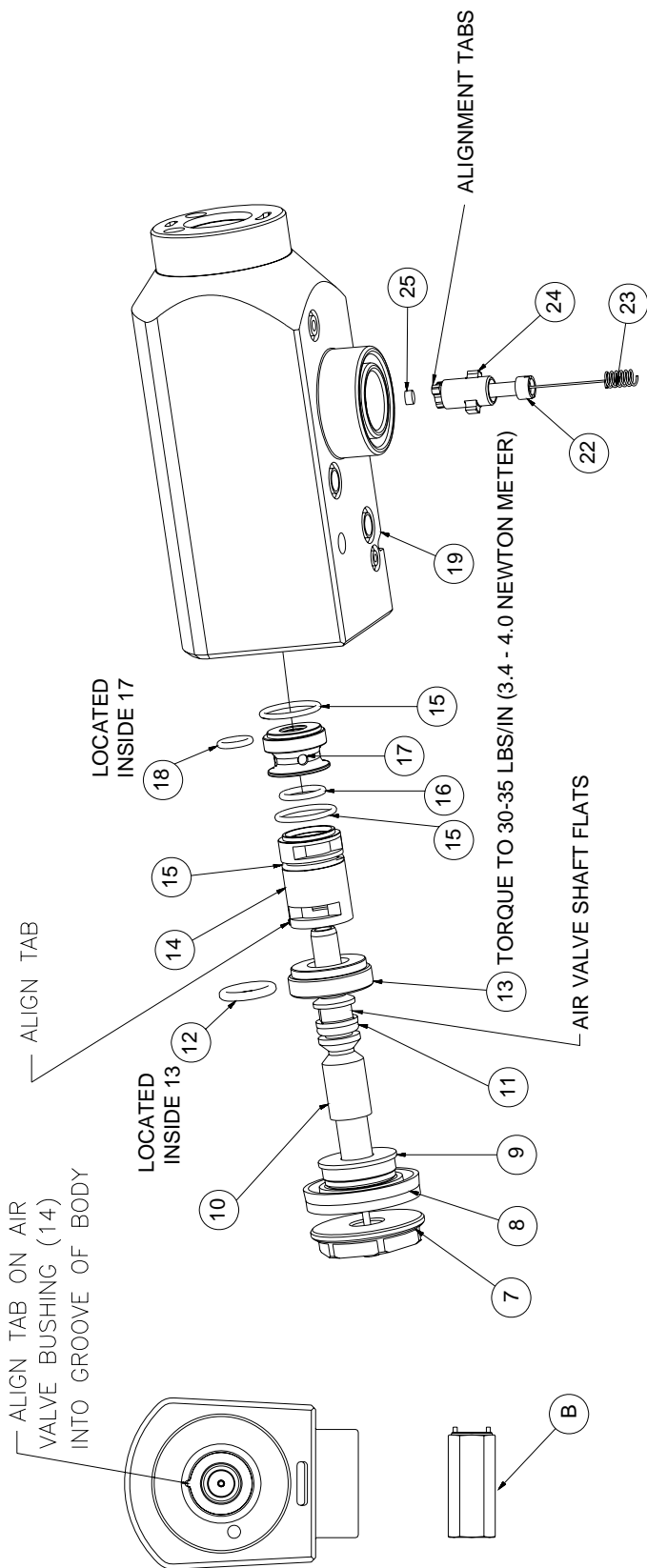

Figure 9: 79138 Evolver Gun Head Assembly



<b>79138 EVOLVER GUN HEAD ASSEMBLY - PARTS LIST (Figure 9)</b>			
<b>Item #</b>	<b>Part #</b>	<b>Description</b>	<b>Qty</b>
7	79147-00	Nut, Piston	1
8	7723-06	Piston, U-Cup	1
9	79145-00	Plate, Piston	1
10	79144-00	Shaft, Air Valve	1
11	79001-28	O-Ring, Solvent Proof	1
12	79001-29	O-Ring, Solvent Proof	1
13	79146-00	Seal Carrier, Rear Piston	1
14	79143-00	Bushing, Air Valve	1
15	79001-01	O-Ring, Solvent Proof	3
16	13076-13	O-Ring, Teflon	1
17	79172-00	Carrier, Rear Seal	1
18	79001-06	O-Ring, Solvent Proof	1
19	79137-00	Head, Machining	1
22	79142-00	Screw, 8-32 X .75" Long, SHCS	1
23	79171-00	Spring, Connector	1
24	79141-00	Plug, Connection	1
25	14061-09	Conductive Compressable Contact	1

## REMOVING GUN FROM THE REAR MANIFOLD ASSEMBLY

(See Figure 10)

Anytime service is required within the gun shroud, the gun must be removed from the rear manifold assembly. After the gun is removed from the robot, always move to a clear, clean work area to remove the gun shroud and begin servicing.

1. Purge all fluid from the system and blow lines dry with pushout air before the gun is removed.
2. All pressures must be removed, both air and fluid, before removing the gun. Fluid pressure can be removed by actuating the gun trigger with the fluid regulator open.
3. Remove gun from robot by turning the retaining ring counter-clockwise from the manifold robot mounting plate (see Figure 10).
4. Remove spray head [1] as described previously (see Figure 10).

### ***Gun Disassembly*** (See Figures 11, 12, and 13)

5. Remove four (4) screws [1] from mounting block and pull block out of the upper manifold [9] as shown in Figure 11.
6. Remove and inspect the o-rings [12, 13, and 37]. Replace if necessary (see Figure 11).
7. Remove retaining ring [22] by pulling straight up as shown in Figure 11.
8. Remove the four (4) screws [28] from the shroud halves. Carefully pry the shroud halves [30] apart by placing a thin blade screwdriver in slot. Pull the shroud half out at the top and up from the valve manifold [3].
9. Loosen one end of the coiled fluid tube [29] by removing the nut [14] and ferrules [15 and 16] from tube fitting [4].

10. Remove the two (2) screws [6] and the two (2) screws [11] from the bottom of the valve body [3] (see Figure 12). Inspect the two (2) o-rings [5] located within the screws [6] and replace if necessary.

11. Carefully pull upward on the head manifold block [9] which will disengage from the bottom valve assembly block [3]. Inspect o-rings [7] and [34], replace if necessary (see Figure 12).

12. Remove the two (2) connecting air rods [18] and the two (2) trigger tie rods [19] by unscrewing counter-clockwise. Remove and inspect the four (4) studs [8] and [21] and the o-rings [35] and [7] and replace if necessary.

13. Remove and inspect the coiled fluid tube by removing the tube nut [25] and ferrule [26] from the upper head manifold [9].

14. Release the cascade cable from the valve manifold by loosening the set screw [17], pull cable out of block, and cascade out of the upper head manifold.

15. Reassemble in reverse order making sure to align the cascade wire plug timing mark with the timing mark on the lower valve block [3] as shown. Tighten set screw [17].

16. Refer to Figure 13 to remove dump and pilot valves. Using the valve removal tool [A], remove the valve assemblies [2] and [32] by turning counter-clockwise. Also use the same tool to remove the seat [1]. When replacing parts lubricate o-rings. Torque both the valve and seat to 15-20 lbs•in (1.7 - 2.0 Nm).

17. The dump line plugs and o-rings [20] and [24] only need to be removed if the valve body becomes plugged.

18. If removing or replacing the ground fluid fitting [4] make sure when reassembling that the washer makes contact with the protruding ground pin.

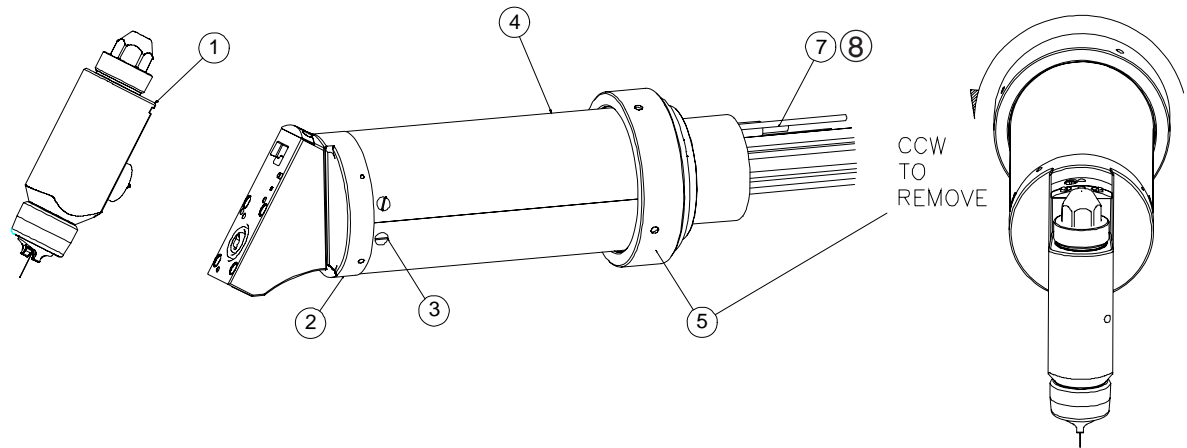

**Figure 10: 79190 Evolver Gun Assembly**

<b>79190 EVOLVER GUN ASSEMBLY - PARTS LIST (Figure 10)</b>			
<b>Item #</b>	<b>Part #</b>	<b>Description</b>	<b>Qty</b>
1	79138-01	Spray Head Assembly, Conventional Spray	1
2	79175-02	Dual Purge, No Regulator	1
3	79161-00	Screw, Flat Head, Slotted	4
4	79157-00	Shroud, Matched Set	1
5	79158-00	Retaining Ring	1
7	79156-XXXX	Rear Manifold Assembly (English)	1
8	A10853-XXXX	Rear Manifold Assembly (Metric)	1

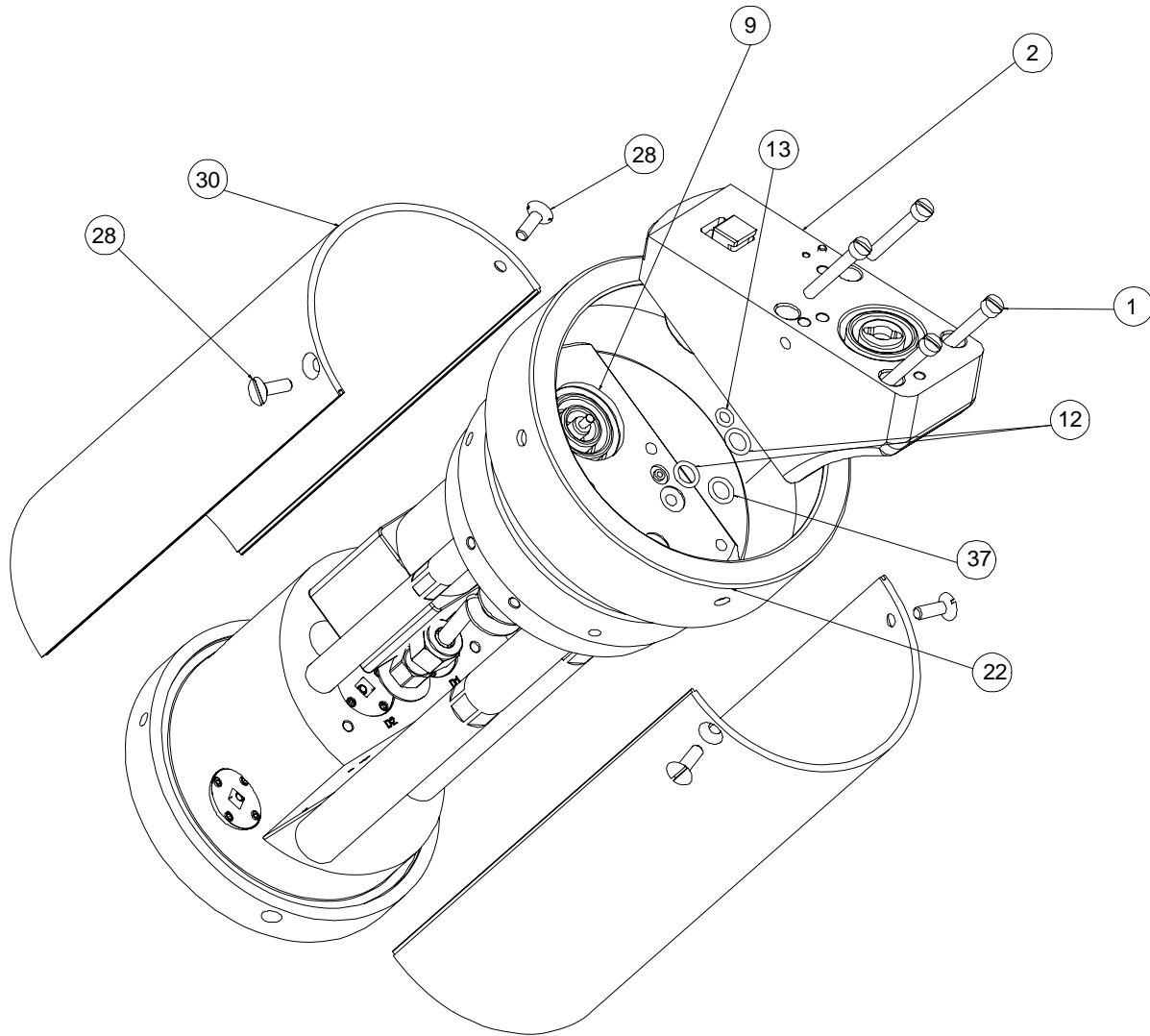

**Figure 11: Mounting Block, Shroud Halves, and Retaining Ring Removal**

<b>MOUNTING BLOCK, SHROUD HALVES, AND RETAINING RING REMOVAL - PARTS LIST (Figure 11)</b>			
<b>Item #</b>	<b>Part #</b>	<b>Description</b>	<b>Qty</b>
1	LSFA0027-00	Screw, for Both Single Head Mounting Blocks	4
	79206-00	Screw, for Both Dual Head Mounting Blocks	
2	79179-00	60° Single Head Mounting Block	1
9	79136-00	Upper Manifold	1
12	79001-06	O-Ring	2
13	79001-04	O-Ring	1
22	79158-00	Retaining Ring	1
28	79161-00	Screw, Flat Head Slotted	4
30	79157-00	Shroud, Matched Set	2
37	79001-14	O-Ring	1

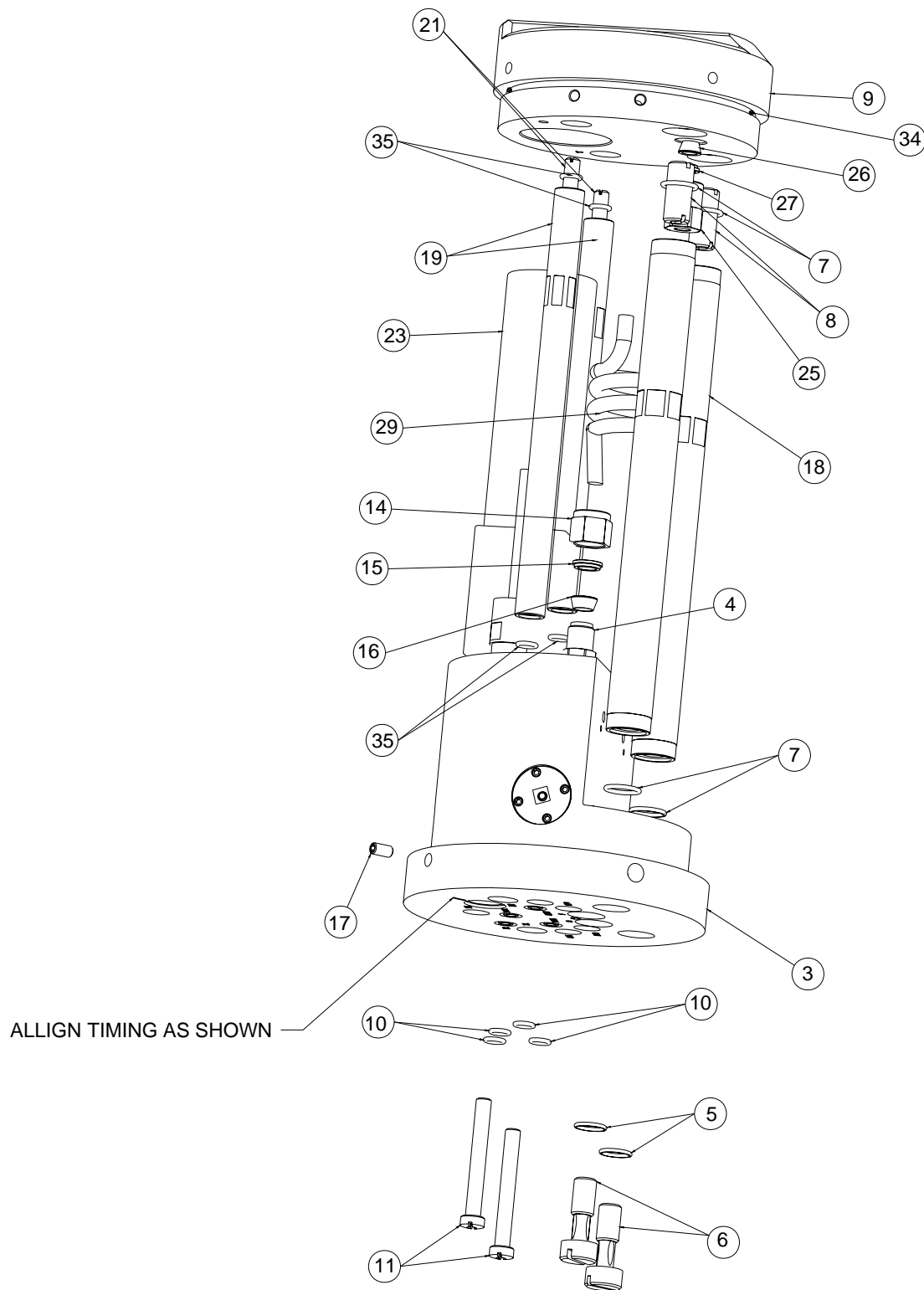

Figure 12: Disassembly of Intermediate Gun Housing

<b>INTERMEDIATE GUN HOUSING - PARTS LIST (Figure 12)</b>			
<b>Item #</b>	<b>Part #</b>	<b>Description</b>	<b>Qty</b>
3	79169-00	Valve Manifold Assembly	1
4	79177-00	Fluid Fitting Assembly	1
5	7554-10	O-Ring	2
6	77508-00	Airbolt, Machined	2
7	7554-11	O-Ring	4
8	77509-00	Threaded Stud	2
9	79136-00	Upper Manifold	1
10	79001-05	O-Ring	4
11	79160-00	Retaining Screw	2
14	70591-01	Fluid Fitting Nut	1
15	70606-01	Front Tube Ferrule	1
16	70607-01	Back Tube Ferrule	1
17	SSF-2052	Set Screw	1
18	79134-00	Connecting Rod	2
19	79135-00	Triggering Tie Rod	2
21	79166-00	Air Connector	2
23	79010-00	HP-404 Cascade Assembly	1
25	78449-00	Fluid Fitting	1
26	EMF-202-04	Back Tube Ferrule	1
27	EMF-203-04	Front Tube Ferrule	1
29	78450-00	Coiled Tube	1
34	79209-00	O-Ring	1
35	7554-07	O-Ring	4

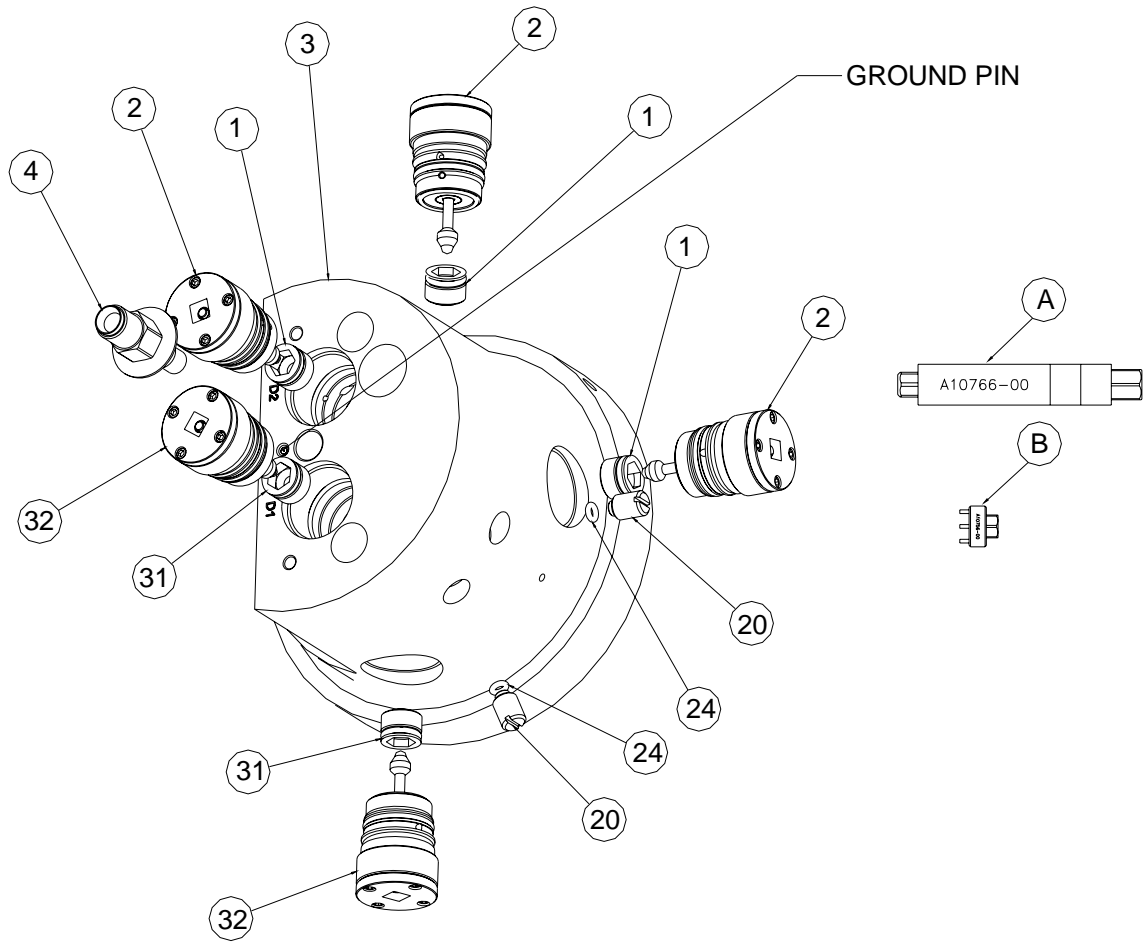
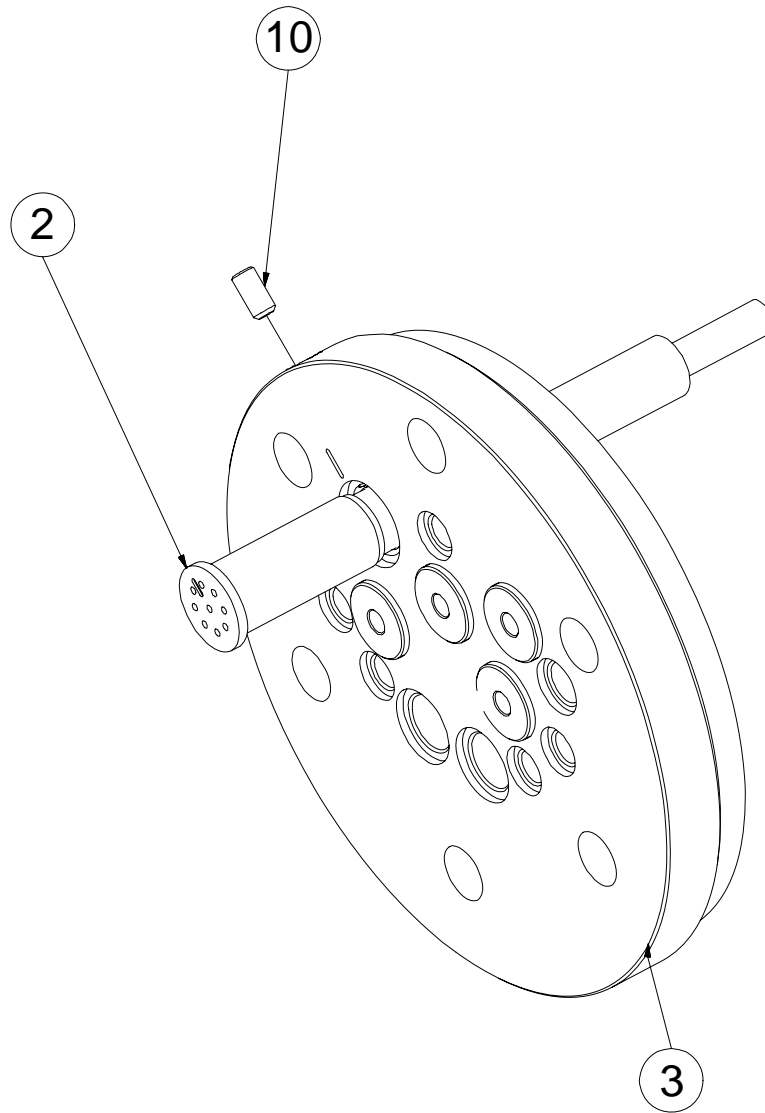

Figure 13: Valve Manifold Disassembly



<b>VALVE MANIFOLD DISASSEMBLY - PARTS LIST (Figure 13)</b>			
<b>Item #</b>	<b>Part #</b>	<b>Description</b>	<b>Qty</b>
1	77367-00	Seat Assembly	3
2	78949-00	Valve Assembly	3
3	79169-00	Lower Manifold Assembly	1
4	79177-00	Fluid Fitting Assembly	1
20	79170-00	Dump Line Plug	2
24	79187-00	O-Ring	2
31	77367-00	Seat Assembly	2
	77620-00	Plug Kit (Optional)	2
32	78949-00	Valve Assembly	2
	77620-00	Plug Kit (Optional)	2
A	A10756-00	Valve Removal Tool (See "79203-00 Tool Kit Figure")	1
B	A10766-00	Valve Seat Removal Tool (See "79203-00 Tool Kit Figure")	1



**Figure 14: Low Voltage Cable Removal**

<b>LOW VOLTAGE CABLE REMOVAL - PARTS LIST (Figure 14)</b>			
<b>Item #</b>	<b>Part #</b>	<b>Description</b>	<b>Qty</b>
2	79008-XX	Low Voltage Cable, One-Piece, for LECU5004-XX Power Supply	1
2	A11353-XX	Low Voltage Cable, One-Piece, for A10406-XX Power Supply	1
2	A11355-XX	Low Voltage Cable, Junction, for A10406-XX Power Supply	1
3	79155-00	Robot Mounting Plate, English Fittings	1
3	A10975-00	Robot Mounting Plate, Metric Fittings	1
10	SSF-2052	Set Screw	1

**Low Voltage Cable Removal  
(Refer to Figure 14)**

1. Disconnect low voltage cable [2] from rear of power supply. For A10406-XX power supply, disconnect circular connector from receptacle on rear of power supply. For LECU5004-XX power supply, disconnect wires from connector J3 at rear of MicroPak.

2. Loosen retaining ring [5] (see Figure 10) and remove applicator from robot wrist.

3. Using 3/16" Allen wrench, remove set screw [10].

4. Remove the low voltage cable [2] by pulling through the robot arm and mounting plate.

5. To reinstall, insert power supply end of cable [2] through mounting plate [3], pull through robot arm and connect to junction box or power supply. For connections to power supply, plug connector into receptacle (A10406-XX power supply) or connect wires as shown in Figure 4 (LECU5004-XX power supply).

6. Align the timing mark of the plug on the applicator end of the cable [2] with the mark on the mounting plate [3] and tighten set screw [10].

**FLUID REGULATOR  
(When Equipped - See Figure 15)**

1. Remove all pressures, both air and fluid from the line leading to the spray gun.

2. Purge all fluid from the gun prior to performing any service.

3. Remove one end of the tubing [39] from the fitting [12]. Remove the six (6) screws [11].

**NOTE**

► Once regulator bonnet [10] is removed, diaphragm [2] will be loose and may fall out.

4. Remove diaphragm assembly [10] and inspect it for wear or damage. Pay particular attention to the air side, since it can be damaged by solvent contact. Replace if necessary.

5. Use a 3/16" Allen wrench to unscrew the poppet seat retainer. The tungsten carbide seat and needle may pop out because of the spring force applied against them.

6. Inspect the needle and seat assembly [4] for wear. If wear or damage is evident, replace. Replace both needle and seat at the same time because they are a matched set. Inspect o-ring (5) for damage, replace as necessary.

7. Reassemble the fluid regulator by inserting the spring [3], needle and seat [5] back into the regulator block assembly. Be sure to lube o-ring. Secure the needle/seat assembly by screwing the seat retainer [4] into the regulator block assembly until a torque of 8-10 lbs•in is obtained.

**NOTE**

- ▶ When replacing the needle seat, be cautious so that the plastic threads are not stripped by cross threading.

8. When replacing the diaphragm [2], remove the screw [9] that holds both halves together. Inspect o-ring [6] for damage. To reassemble, make sure that the Teflon side is toward the lower support [8]. Reinstall screw and tighten. Be careful not to over tighten. If the diaphragm is inserted wrong, damage will occur. Push the diaphragm assembly down in valve body aligning the screw holes.

9. Tighten the regulator bonnet [10] to the block assembly [1] securely with the six (6) screws [11] in an alternating 180° method. Reinstall the tube.

10. To remove the complete regulator assembly from the gun, remove the coiled tube [29] by removing the tubing nut and ferrules [25], [26], and [27].

11. Remove the regulator assembly from the fluid inlet fitting [13] by removing the nut and ferrules [13], [14], and [15] and pull up and out.

12. Reinstall the coiled tube [29] as shown in Figure 15; one of the coils of the tube must be wrapped around the cascade as shown. Reattach the pilot tube [39] to the regulator bonnet.

13. Reassemble the remainder in reverse order.

**NOTES**

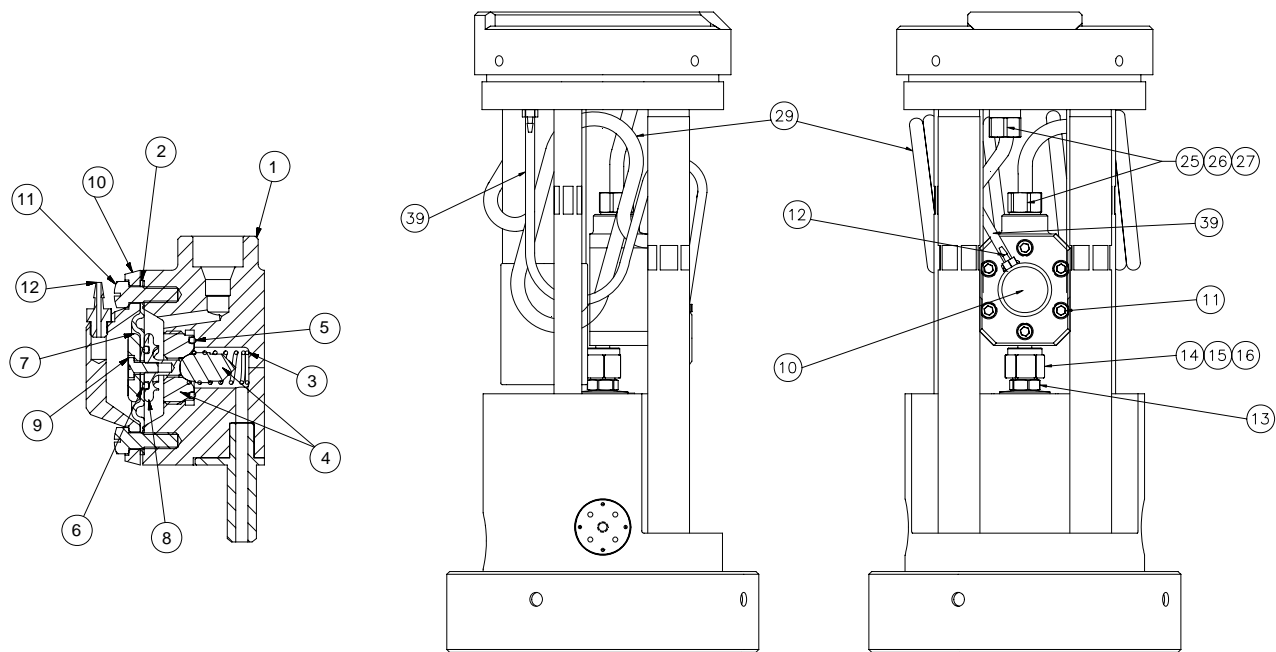

**Figure 15: Fluid Regulator Assembly**

<b>FLUID REGULATOR ASSEMBLY - PARTS LIST (Figure 15)</b>			
<b>Item #</b>	<b>Part #</b>	<b>Description</b>	<b>Qty</b>
1	A11901-00	Regulator Block Assembly	1
2	79220	Diaphragm	1
3	74161	Spring, Regulator	1
4	77354-00	Assembly, Needle and Seat	1
5	79001-08	O-Ring, Solvent Proof	1
6	79001-06	O-Ring, Solvent Proof	1
7	79222	Upper Plate, Regulator	1
8	79221	Lower Plate, Regulator	1
9	76374-08C	Screw	1
10	79223	Bonnet, Regulator	1
11	LSFA-0026	Screw, Slotted Fillister Head	6
12	75699-01	Fitting, Barb, Natural Color	1
13	79177-00	Assembly, Fluid Fitting	1
14	70591-01	Nut, Fluid Fitting. 1/4" Tube	1
15	70606-01	Ferrule, Front, 1/4" Tube	1
16	70607-01	Ferrule, Back, 1/4" Tube	1
25	78449-00	Fitting, Fluid	2
26	EMF-202-04	Ferrule, Back, 1/4" Tube	2
27	EMF-203-04	Ferrule, Front, 1/4" Tube	2
29	A-10456	Tube, Coiled	1
39	H-2382	Tubing	1

# A10406 OR LECU5004 MICROPAK CONTROL UNIT

(See the current "MicroPak" Service Manual supplied with the control unit for service information.)

## ACCESSORIES

Accessories for the Evolver Solventborne Spray Guns include:

- 75777-XX Gun Covers
- 74035-XX Test Air Cap and Gauge Assy.
- 73896-01 Electrode and Air Cap Protector
- 79203-00 Tool Kit
- A10408 Manifold O-Ring Kit
- A10407 Mounting Plate O-Ring Kit
- A10409 Regulator Repair Kit
- A10410 Spray Head Plate O-Ring Kit
- A10411 Spray Head Repair Kit
- 77620-00 Valve Plug Kit

<b>75777-XX GUN COVERS</b>	
Part #	Description
75777-01	Single Head Gun
75777-02	Dual Head Gun
75777-03	Robot Wrist Flange

<b>74035-XX TEST AIR CAPS &amp; GAUGE ASSEMBLY</b>	
Part #	Description
74035-21	#65R-1 Test Cap
74035-22	#98-1 Test Cap
74035-23	#63-1 Test Cap
74035-24	#48-1 Test Cap
74035-25	#481-1 Test Cap

The 74035, Test Air Cap and Gauge Assembly, is designed for use with a Test Station or while the gun is connected to the robot or reciprocator. The test air cap is comprised of two air pressure gauges, pressure gauge stand, special 74061-XX air caps, and all required tubing and fittings.

The air cap has two tapped holes for small barbed tube fittings. The fittings are located so that the gauges connected to them will measure the actual cap pressure of the atomization and pattern air. Using this test cap will assure uniform atomization and pattern quality, regardless of air supply tube lengths from one gun to another.

### 73896-01 Electrode and Air Cap Protector

This is a plastic cylinder that fits over the air cap retainer. The protector keeps the electrode and other spray head parts from being damaged during booth cleaning and at other times when the spray gun is not in use.

### 79203-00 Tool Kit

Provided with each gun is a tool kit to aid in the disassembly and assembly of the gun during servicing.

<b>79203-00 TOOL KIT (For Dual Head Guns)</b>	
Part #	Description
A10756-00	Valve Removal Tool
A10766-00	Valve Seat Removal Tool
76772-00	Retaining Ring Spanner
A10400	Seal Carrier Tool

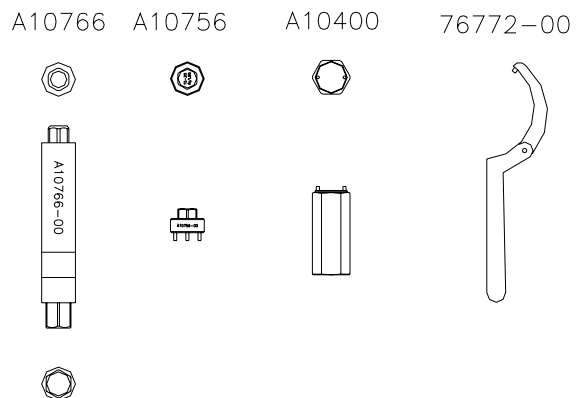

Figure 16: 79203-00 Tool Kit

<b>A10407 MOUNTING PLATE O-RING KIT</b>		
Part #	Description	Qty
79001-05	O-Ring, Solvent Proof	9
79001-06	O-Ring, Solvent Proof	2
79001-07	O-Ring, Solvent Proof	2
79001-01	O-Ring, Solvent Proof	1

<b>A10408 MANIFOLD O-RING KIT</b>		
Part #	Description	Qty
7554-10	O-Ring, Solvent Resistant	2
7554-11	O-Ring, Solvent Resistant	4
79001-05	O-Ring, Solvent Proof	4
79001-06	O-Ring, Solvent Proof	2
79001-04	O-Ring, Solvent Proof	1
79209-00	O-Ring, Solvent Resistant	1
7554-07	O-Ring, solvent Resistant	4
79001-09	O-Ring, Solvent Proof	1
79001-14	O-Ring, Solvent Proof	1

<b>10409 REGULATOR REPAIR KIT</b>		
Part #	Description	Qty
79220-00	Diaphragm	1
74161-00	Spring	1
77354-00	Needle & Seat	1
79001-08	O-Ring, Solvent Proof	1
79001-06	O-Ring, Solvent Proof	1

<b>A10410 SPRAY HEAD O-RING KIT</b>		
Part #	Description	Qty
79001-04	O-Ring, Solvent Proof	1
79001-06	O-Ring, Solvent Proof	1
79001-05	O-Ring, Solvent Proof	1

<b>A10411 SPRAY HEAD REPAIR KIT</b>		
Part #	Description	Qty
79151-00	Needle Shaft	1
7723-06	Piston, U-Cup	1
79001-28	O-Ring, Solvent Proof	1
79001-29	O-Ring, Solvent Proof	1
13076-13	O-Ring, Teflon	1
RME-38	Spring	1
RME-32	Seal	1
79001-01	O-Ring, Solvent Proof	4
79001-04	O-Ring, Solvent Proof	1
79001-06	O-Ring, Solvent Proof	3
79001-05	O-Ring, Solvent Proof	1

<b>77620-00 VALVE PLUG KIT (Optional - Use In Place Of Valve &amp; Seat)</b>		
Part #	Description	Qty
79244-00	Plug	1
77618-00	Plug Seat	1
79001-19	O-Ring, Solvent Proof	1
79001-14	O-Ring, Solvent Proof	1

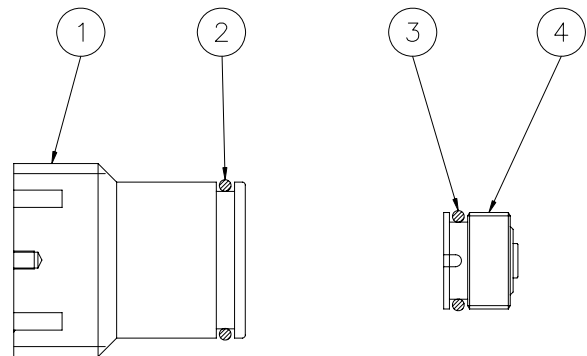

**Figure 17: 77620-00 Valve Plug Assembly**

# TROUBLESHOOTING GUIDE

General Problem	Possible Causes	Corrective Action
<p><b>Fluid Does Not Turn On</b></p>	<ol style="list-style-type: none"> <li>1. Trigger pilot regulator has not been set to a minimum of 70 psig</li> <li>2. The green air tube possibly left disconnected during re-assembly</li> <li>3. Green tube leading from the source to the gun mounting plate is pinched or broken</li> <li>4. Piston seal within the gun spray head is not in place or there is an extremely tight fit between the seal and the cylinder wall</li> </ol>	<ol style="list-style-type: none"> <li>1. Increase to 70 psig minimum.</li> <li>2. Reconnect tubing.</li> <li>3. Check the tubing for kinks or damage. Replace if worn or damaged.</li> <li>4a. Make sure that the seal is in the proper position and/or lubricate with a small amount of petroleum jelly.</li> <li>4b. O-rings left out of small Ø tie rods.</li> <li>4c. O-ring missing between mounting block and upper manifold.</li> <li>4d. O-ring missing between mounting block and replaceable head.</li> </ol>
<p><b>No Fan or Atomization Air Pressure At the Air Cap</b></p>	<ol style="list-style-type: none"> <li>1. Low trigger pilot air pressure (70 psi min. required)</li> <li>2. Air tubes 79134-00 are not installed properly.</li> <li>3. Black or natural 3/8" OD tube is cut or pinched</li> </ol>	<ol style="list-style-type: none"> <li>1. Increase pressure.</li> <li>2. Reinstall and tighten as required.</li> <li>3. Examine, repair as required.</li> </ol>

Note: A test station to bench test the applicator off-line will speed the Troubleshooting process.



## TROUBLESHOOTING GUIDE (Cont.)

### Fluid System

General Problem	Possible Causes	Corrective Action
<b>Excessive Current or Loss of High Voltage</b>	<ol style="list-style-type: none"> <li>1. Metallic particle alignment in coiled tube</li> <li>2. Fluid leaks inside</li> <li>3. Fluid coil pin-holed</li> <li>4. Exterior of gun contaminated</li> </ol>	<ol style="list-style-type: none"> <li>1. Start fluid flow before turning voltage on.</li> <li>2. Repair/replace fittings and/or coiled fluid tube as required.</li> <li>3. Replace coil as required.</li> <li>4. Clean with non-polar solvent.</li> </ol>

Note: To check for fluid leaks, it is easiest to first remove the gun from the test station and remove the shroud from the gun. Then the gun can be remounted to the test station. Leak detector may be used at all appropriate sources. Be certain to wipe off all residual solution using a non-conductive solvent such as Naphtha.

### Electrical

General Problem	Possible Causes	Corrective Action
<b>No Electrostatics</b>	<ol style="list-style-type: none"> <li>1. Cascade not functioning</li> </ol>	<ol style="list-style-type: none"> <li>1. Check low voltage cable and harness timing mark positions. Correct as required.</li> <li>2. Cascade bad. Replace as required.</li> <li>3. Low voltage cable connections wrong at MicroPak.</li> <li>4. Low voltage cable bad. Replace as required.</li> </ol>
<b>Low kV, High <math>\mu</math>A Output</b>	<ol style="list-style-type: none"> <li>1. Exterior of gun contaminated with conductive material</li> </ol>	<ol style="list-style-type: none"> <li>1. Replace gun cover.</li> <li>2. Clean exterior with a non-polar solvent.</li> </ol>
<b>Low kV, Low <math>\mu</math>A Output</b>	<ol style="list-style-type: none"> <li>1. Cascade failure</li> </ol>	<ol style="list-style-type: none"> <li>1. Replace as required.</li> </ol>

# PARTS IDENTIFICATION

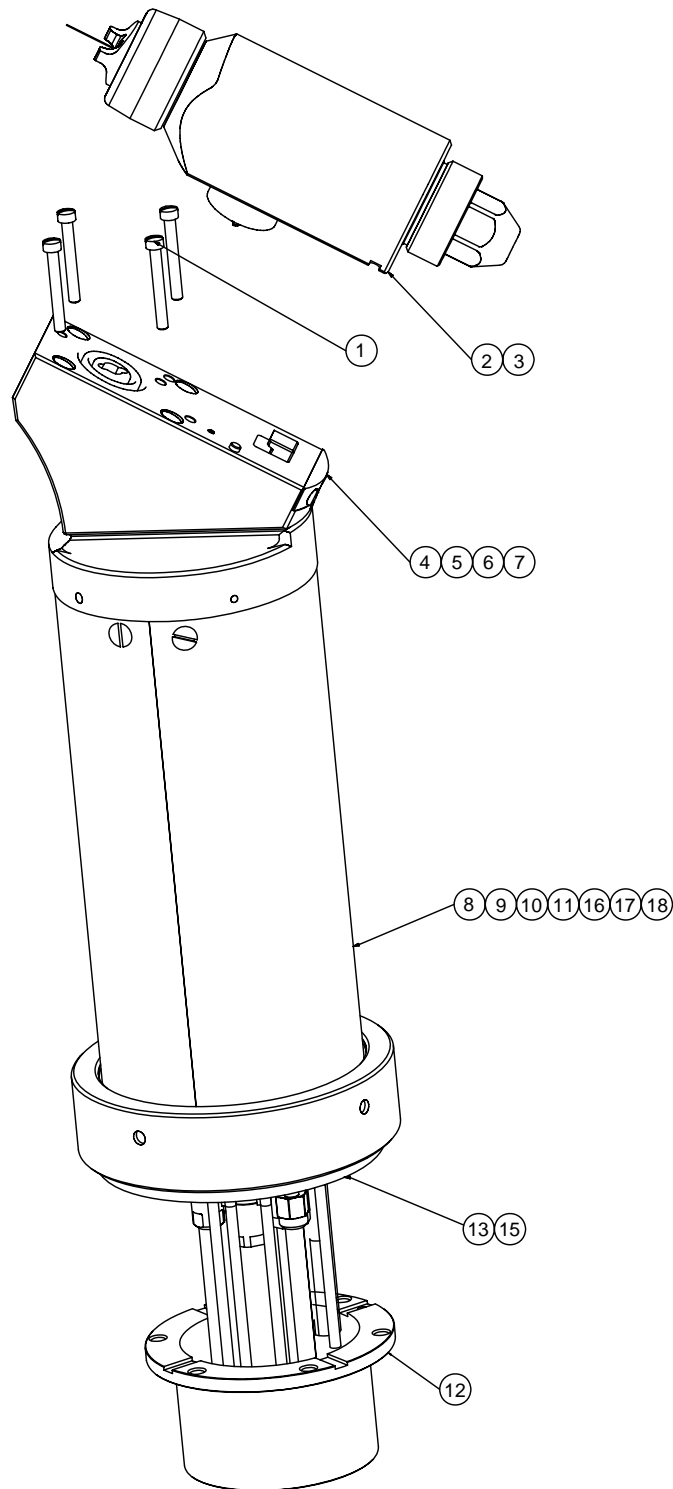

Figure 18: 79190-XXXXXXXX Gun Assembly

<b>79190-XXXXXXXXX GUN ASSEMBLY - PARTS LIST (Figure 18)</b>		
<b>Item #</b>	<b>Part #</b>	<b>Description</b>
1	<b>Table B - "Y"</b>	Screw, #10-32, Fiberglass, Fillister Head, Machined
2	<b>Table A - "Z"</b>	Spray Head Assembly
4	79179-00	Assembly, Mounting Block 60° Single Head
5	79180-00	Assembly, Mounting Block 90° Single Head
6	79243-00	Assembly, Mounting Block 60° Dual Head
7	79224-00	Assembly, Mounting Block 90° Dual Head
8	79175-01	Single Purge, No Regulator
9	79175-02	Dual Purge, No Regulator
10	79175-03	Single Purge, W/Regulator
11	79175-04	Dual Purge, W/Regulator
12	<b>Table D - "S"</b>	Robot Adapters
13	<b>Table FF - "W"</b>	Rear Manifold Assembly
14	<b>Table G - "X"</b>	Power Supply (Not Shown)
16	79175-05	Single Purge, No Regulator, Non-Electrostatic
17	79175-06	Dual Purge, No Regulator, Non-Electrostatic
18	79175-07	Single Supply, No Valves, Short Tube

<b>TABLE A ATOMIZATION TECHNOLOGY</b>		
<b>Dash No.</b>	<b>Description</b>	<b>"Z"</b>
0	Conventional Spray	79138-01
1	HVLP Spray	79138-02

<b>TABLE B HEAD CONFIGURATION</b>		
<b>Dash No.</b>	<b>Description</b>	<b>"Y"</b>
0	60° Single Head	LSFA0027-00
1	90° Single Head	LSFA0027-00
2	60° Double Head	79206-00
3	90° Double Head	79206-00

<b>TABLE D ROBOT ADAPTERS</b>		
<b>Dash No.</b>	<b>Description</b>	<b>"S"</b>
0	No Adapter	----
1	"ABB" Robot Adapter	79107-00
2	"FANUC" P-155 Robot Adapter	78983-00
3	"FANUC" P-200 Robot Adapter	79131-00
4	Adapter (Kaswsaki-KE610L)	A10847-00
5	Adapter (Motoman-PX2850)	A10848-00
6	Adapter (Motomanu-PX2900)	A10849-00

<b>TABLE FF - REAR MANIFOLD ASSEMBLY</b>		
<b>Dash No.</b>	<b>Description</b>	<b>"W"</b>
00	No Rear Manifld Assembly	----
23	No Cable, English Manifold	79156-XX00
24	No Cable, Metric Manifold	A10853-XX00
<b>English Manifold W/LECU5004-XX Power Supply Cable</b>		
01	25' One-Piece Cable	79156-XX01
02	50' One-Piece Cable	79156-XX02
03	75' One-Piece Cable	79156-XX03
04	100' One-Piece Cable	79156-XX04
05	15' Robot to Junction Box; 15' Junction Box to MicroPak	79156-XX05
06	15' Robot to Junction Box; 40' Junction Box to MicroPak	79156-XX06
07	15' Robot to Junction Box; 60' Junction Box to MicroPak	79156-XX07
08	15' Robot to Junction Box; 75' Junction Box to MicroPak	79156-XX08
09	25' Robot to Junction Box; 25' Junction Box to MicroPak	79156-XX09
10	25' Robot to Junction Box; 50' Junction Box to MicroPak	79156-XX10
11	25' Robot to Junction Box; 75' Junction Box to MicroPak	79156-XX11
<b>Metric Manifold W/LECU5004-XX Power Supply Cable</b>		
12	7.6m One-Piece Cable	A10853-XX01
13	15.2m One-Piece Cable	A10853-XX02
14	22.9m One-Piece Cable	A10853-XX03
15	30.5m One-Piece Cable	A10853-XX04
16	4.6m Robot to Junction Box; 4.6m Junction Box to MicroPak	A10853-XX05
17	4.6m Robot to Junction Box; 12.2m Junction Box to MicroPak	A10853-XX06
18	4.6m Robot to Junction Box; 18.3m Junction Box to MicroPak	A10853-XX07
19	4.6m Robot to Junction Box; 22.9m Junction Box to MicroPak	A10853-XX08
20	7.6m Robot to Junction Box; 7.6m Junction Box to MicroPak	A10853-XX09
21	7.6m Robot to Junction Box; 15.2m Junction Box to MicroPak	A10853-XX10
22	7.6m Robot to Junction Box; 22.9m Junction Box to MicroPak	A10853-XX11
<b>English Manifold W/A10406-XX Power Supply Cable</b>		
31	25' One-Piece Cable	79156-XX31
32	50' One-Piece Cable	79156-XX32
33	75' One-Piece Cable	79156-XX33
34	100' One-Piece Cable	79156-XX34
35	15' Robot to Junction Box; 15' Junction Box to MicroPak	79156-XX35
36	15' Robot to Junction Box; 40' Junction Box to MicroPak	79156-XX36
37	15' Robot to Junction Box; 60' Junction Box to MicroPak	79156-XX37
38	15' Robot to Junction Box; 75' Junction Box to MicroPak	79156-XX38
39	25' Robot to Junction Box; 25' Junction Box to MicroPak	79156-XX39
40	25' Robot to Junction Box; 50' Junction Box to MicroPak	79156-XX40
41	25' Robot to Junction Box; 75' Junction Box to MicroPak	79156-XX41

(Continued On Next Page)

<b>TABLE FF - REAR MANIFOLD ASSEMBLY (Cont.)</b>		
<b>Dash No.</b>	<b>Description</b>	<b>"W"</b>
<b>Metric Manifold W/A10406-XX Power Supply Cable</b>		
51	7.6m One-Piece Cable	79156-XX31
52	15.2m One-Piece Cable	79156-XX32
53	22.9m One-Piece Cable	79156-XX33
54	30.5m One-Piece Cable	79156-XX34
55	4.6m Robot to Junction Box; 4.6m Junction Box to MicroPak	79156-XX35
56	4.6m Robot to Junction Box; 12.2m Junction Box to MicroPak	79156-XX36
57	4.6m Robot to Junction Box; 18.3m Junction Box to MicroPak	79156-XX37
58	4.6m Robot to Junction Box; 22.9m Junction Box to MicroPak	79156-XX38
59	7.6m Robot to Junction Box; 7.6m Junction Box to MicroPak	79156-XX39
60	7.6m Robot to Junction Box; 15.2m Junction Box to MicroPak	79156-XX40
61	7.6m Robot to Junction Box; 22.9m Junction Box to MicroPak	79156-XX41

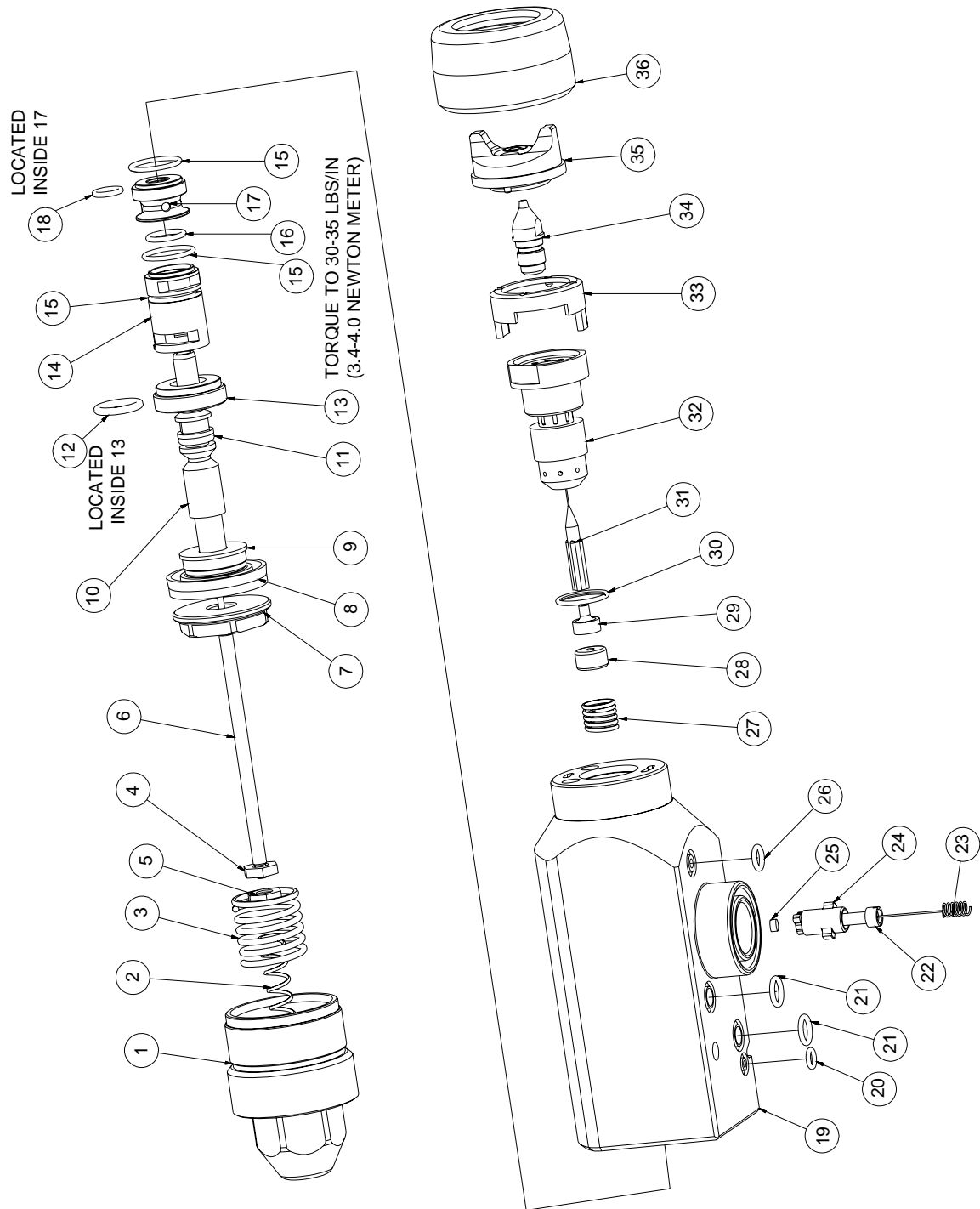

Figure 19: Spray Head Assembly

**79138-01 CONVENTIONAL SPRAY HEAD ASSEMBLY -  
PARTS LIST (Figure 19)**

Item #	Part #	Description	Qty
1	79148-00	End Cap, Spray Head	1
2	17615-00	Spring, Compression	1
3	9334-00	Spring, Valve Return	1
4	7733-07	Nut, Jam	1
5	76199-00	Nut, Adjustment Rear	1
6	79151-00	Assembly, Needle Shaft	1
7	79147-00	Nut, Piston	1
8	7723-06	Piston, U-Cup	1
9	79145-00	Plate, Piston	1
10	79144-00	Shaft, Air Valve	1
11	79001-28	O-Ring, Solvent Proof	1
12	79001-29	O-Ring, Solvent Proof	1
13	79146-00	Seal Carrier, Rear Piston	1
14	79143-00	Bushing, Air Valve	1
15	79001-01	O-Ring, Solvent Proof	3
16	13076-13	O-Ring, Teflon	1
17	79172-00	Carrier, Rear Seal	1
18	79001-06	O-Ring, Solvent Proof	1
19	79137-00	Head, Machining	1
20	79001-04	O-Ring, Solvent Proof	1
21	79001-06	O-Ring, Solvent Proof	2
22	79142-00	Screw, SHCS	1
23	79171-00	Spring, Connector	1
24	79141-00	Plug, Connection	1
25	14061-09	Conductive Compressable Contact	1
26	79001-05	O-Ring, Solvent Proof	1
27	RME-38	Return Spring, Piston	1
28	EMF-7	Seal, Washer	1
29	RME-32	Seal	1
30	79001-01	O-Ring, Solvent Proof	1
31	70430-01	Electrode, High Wear	1
32	EMF-195	Nozzle, Fluid Hole (8)	1
33	EMF-192	Locator, Air Cap	1
34	79140-01	Fluid Tip, .042 (1.07mm) Diameter	1
	79140-02	Fluid Tip, .055 (1.40mm) Diameter	1
	79140-03	Fluid Tip, .070 (1.78mm) Diameter	1
35	79153-65R-1	Air Cap, Certified 65R-1	1
	79196-98-1	Air Cap, Certified 98-1	1
	79197-63-1	Air Cap, Certified 63-1	1
36	79154-00	Ring, Retaining	1

**79138-02 HVLP SPRAY HEAD ASSEMBLY - PARTS LIST**  
**(Figure 19)**

Item #	Part #	Description	Qty
1	79148-00	End Cap, Spray Head	1
2	17615-00	Spring, Compression	1
3	9334-00	Spring, Valve Return	1
4	7733-07	Nut, Jam	1
5	76199-00	Nut, Adjustment Rear	1
6	79151-00	Assembly, Needle Shaft	1
7	79147-00	Nut, Piston	1
8	7723-06	Piston, U-Cup	1
9	79145-00	Plate, Piston	1
10	79144-00	Shaft, Air Valve	1
11	79001-28	O-Ring, Solvent Proof	1
12	79001-29	O-Ring, Solvent Proof	1
13	79146-00	Seal Carrier, Rear Piston	1
14	79143-00	Bushing, Air Valve	1
15	79001-01	O-Ring, Solvent Proof	3
16	13076-13	O-Ring, Teflon	1
17	79172-00	Carrier, Rear Seal	1
18	79001-06	O-Ring, Solvent Proof	1
19	79137-00	Head, Machining	1
20	79001-04	O-Ring, Solvent Proof	1
21	79001-06	O-Ring, Solvent Proof	2
22	79142-00	Screw, SHCS	1
23	79171-00	Spring, Connector	1
24	79141-00	Plug, Connection	1
25	14061-09	Conductive Compressable Contact	1
26	79001-05	O-Ring, Solvent Proof	1
27	RME-38	Return Spring, Piston	1
28	EMF-7	Seal, Washer	1
29	RME-32	Seal	1
30	79001-01	O-Ring, Solvent Proof	1
31	70430-01	Electrode, High Wear	1
32	79183-00	Nozzle, Fluid Hole (8) (HVLP)	1
33	EMF-192	Locator, Air Cap	1
34	79182-01	Fluid Tip, .028 (.71mm) Diameter (Used with Air Cap 79186-48-1)	1
	79182-02	Fluid Tip, .042 (1.07mm) Diameter (Used with Air Cap 79186-48-1)	1
	79182-03	Fluid Tip, .055 (1.40mm) Diameter (Used with Air Cap 79186-48-1)	1
	79182-04	Fluid Tip, .070 (1.78mm) Diameter (Used with Air Cap 79186-48-1)	1
	79182-05	Fluid Tip, .086 (2.18mm) Diameter (Used with Air Cap 79186-48-1)	1
35	79185-48-1	Air Cap, Certified 48-1 (Used with 79182-01, 02, 03 Tips)	1
	79186-481-1	Air Cap, Certified 481-1 (Used with 79182-04, 05 Tips)	1
36	79154-00	Ring, Retaining	1



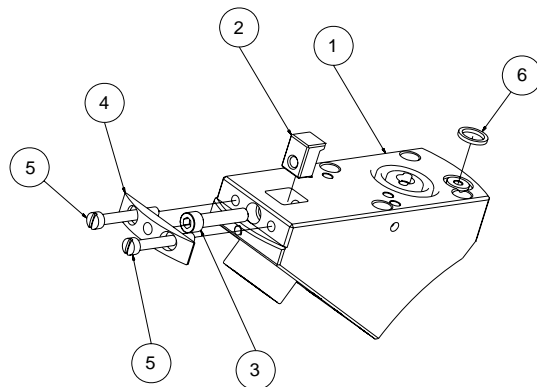

Figure 20: 79179-00 Single Head 60°

<b>79179-00 SINGLE HEAD 60° - PARTS LIST (Figure 20)</b>			
Item #	Part #	Description	Qty
1	79188-00	Assembly, Mounting Block 60° Single Head	1
2	79173-00	Block, Locking	1
3	79174-00	Screw, Nylon 1/4-20 x 1-1/4" Long	1
4	79184-00	Plate, Retention	1
5	79149-00	Screw, Retaining 10-32 x .50" Long NY	2
6	A-10612	Square Cut Ring, Solvent Proof	1

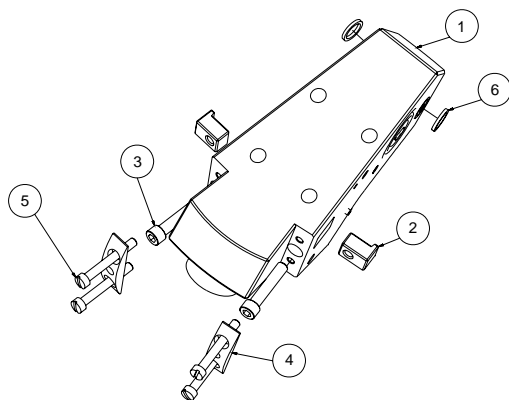

Figure 21: 79243-00 Dual Head 60°

<b>79243-00 DUAL HEAD 60° - PARTS LIST (Figure 21)</b>			
Item #	Part #	Description	Qty
1	79242-00	Assembly, 60° Block Dual Head	1
2	79173-00	Block, Locking	2
3	79174-00	Screw, Nylon 1/4-20 X 1-1/4" Long	2
4	79184-00	Plate, Retention	2
5	79149-00	Screw, Retaining 10-32 X .50" Long NY	4
6	A-10612	Square Cut Ring, Solvent Proof	2

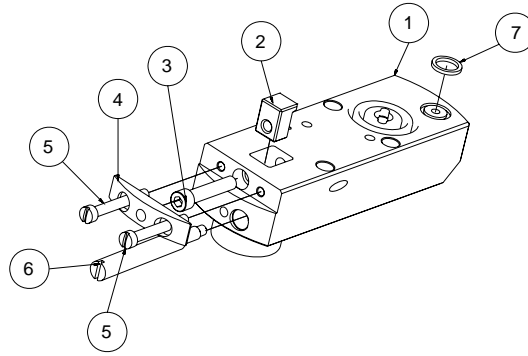

Figure 22: 79180-00 Single Head 90°

<b>79180-00 SINGLE HEAD 90° - PARTS LIST (Figure 22)</b>			
Item #	Part #	Description	Qty
1	79189-00	Assembly, Mounting Block 90° Single Head	1
2	79173-00	Block, Locking	1
3	79174-00	Screw, Nylon 1/4-20 X 1-1/4" Long	1
4	79184-00	Plate, Retention	1
5	79149-00	Screw, Retaining 10-32 X .50" Long NY	2
6	79194-00	Plug, Fluid Flush	1
7	A-10612	Square Cut Ring, Solvent Proof	1

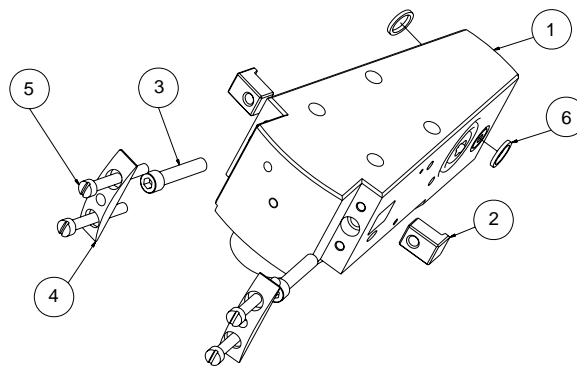
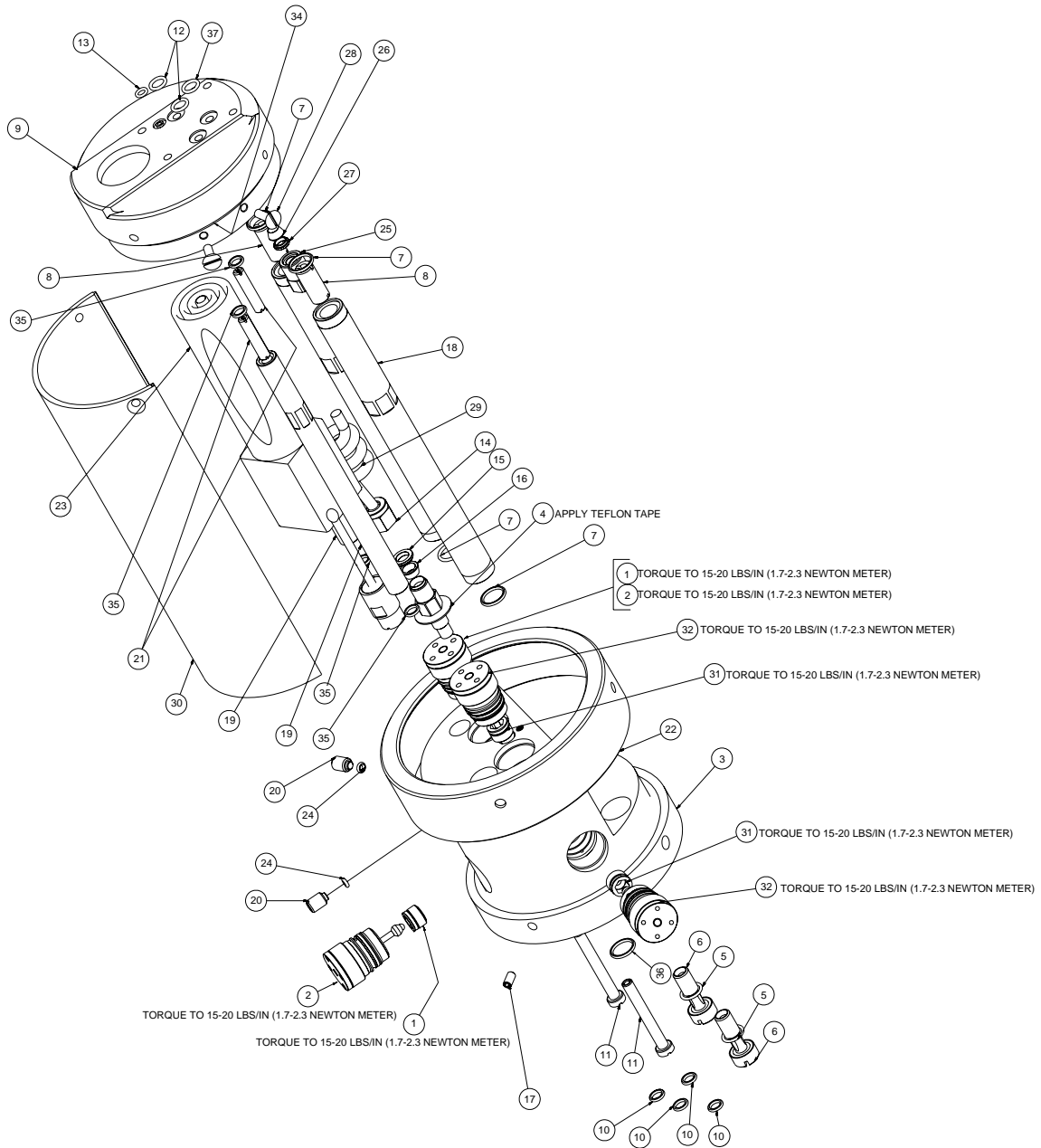
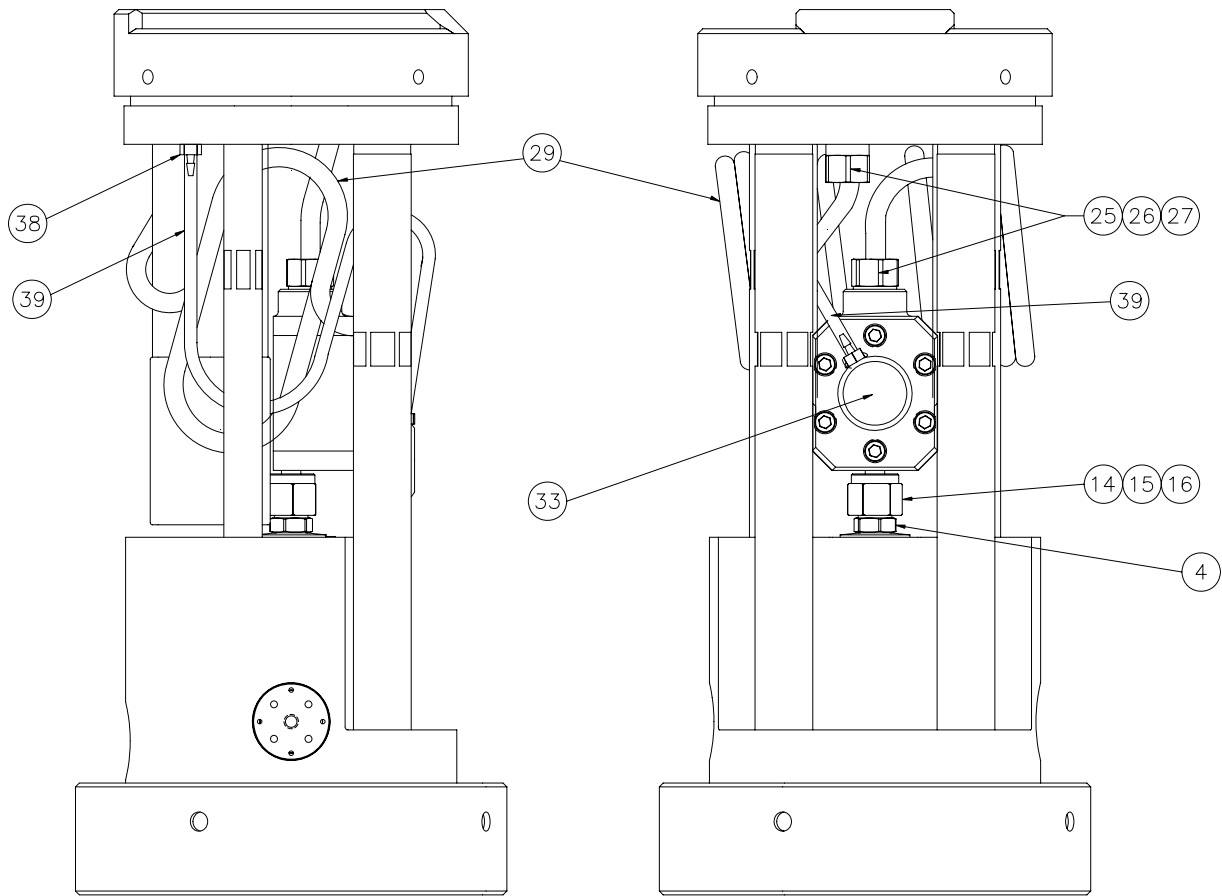

Figure 23: 79224-00 Dual Head 90°

<b>79224-00 DUAL HEAD 90° - PARTS LIST (Figure 23)</b>			
Item #	Part #	Description	Qty
1	79227-00	Assembly, Mounting Block 90° Dual Head	1
2	79173-00	Block, Locking	2
3	79174-00	Screw, Nylon 1/4-20 X 1-1/4" Long	2
4	79184-00	Plate, Retention	2
5	79149-00	Screw, Retaining 10-32 X .50" Long NY	4
6	A-10612	Square Cut Ring, Solvent Proof	2



**Figure 24: 79175-XX Manifold Assembly**



**Figure 25: 79175-XX Optional Regulated Version**

<b>79175-XX MANIFOLD ASSEMBLY - PARTS LIST (Figures 24 &amp; 25)</b>			
<b>Item #</b>	<b>Part #</b>	<b>Description</b>	<b>Qty</b>
1	77367-00	Seat Assembly	3
2	78949-00	Valve Assembly	3
3	79169-00	Assembly, Lower Manifold	1
4	79177-00	Assembly, Fluid Fitting	1
5	7554-10	O-Ring, Solvent Resistant	2
6	77508-00	Air Bolt, Machined	2
7	7554-11	O-Ring, Solvent Resistant	4
8	77509-00	Threaded Stud, Machined	2
9	79136-00	Manifold, Upper	1
10	79001-05	O-Ring, Solvent Proof	4
11	79160-00	Screw, Retaining, 1/4-20 X 2" Long, Stainless Steel	2
12	79001-06	O-Ring, Solvent Proof	2
13	79001-04	O-Ring, Solvent Proof	1
14	70591-01	Nut, Fluid Fitting, 1/4"	1
15	70606-01	Ferrule, Front 1/4" Tube	1
16	70607-01	Ferrule, Back 1/4" Tube	1
17	SSF-2052	Set Screw, 3/8" Long X 10-24	1
18	79134-00	Connecting Rod, Machined	2
19	79135-00	Tie Rod, Triggering	2
20	79170-00	Plug, Dump Line	2
21	79166-00	Connector, Air	2
22	79158-00	Retaining Ring	1
23	<b>Assy. Table - "P"</b>	Cascade Assembly, HP-404	1
24	79187-00	O-Ring, Teflon	2
25	78449-00	Fitting, Fluid	<b>"L"</b>
26	EMF-202-04	Ferrule, Back 1/4" Tube	<b>"M"</b>
27	EMF-203-04	Ferrule, Front 1/4" Tube	<b>"N"</b>
28	79161-00	Flat Head Slotted Screw, 10-32 X .5" Long	4
29	<b>Assy. Table - "G"</b>	Tube, Coiled, 1/4" OD X 1/8" ID	1
30	79157-00	Shroud, Matched Set	1
31	<b>Assy. Table - "A"</b>	Seat Assembly or Plug	2
32	<b>Assy. Table - "B"</b>	Valve Assembly or Plug	2
33	<b>Assy. Table - "C"</b>	Regulator, Fluid	1
34	79209-00	O-Ring, Solvent Resistant	1
35	7554-07	O-Ring, Solvent Resistant	4
36	79001-09	O-Ring, Solvent Proof	1
37	79001-14	O-Ring, Solvent Proof	1
38	<b>Assy. Table - "H"</b>	Fitting, Barb, Natural Color	1
39	<b>Assy. Table - "I"</b>	Urethane Tubing, 1/16" ID X 1/8" OD	1

<b>79175-XX MANIFOLD ASSEMBLY TABLE</b>						
<b>Part #</b>	<b>Description</b>	<b>"A"</b>	<b>"B"</b>	<b>"C"</b>	<b>"G"</b>	<b>"H"</b>
79175-01	Single Purge - No Regulator	Kit #77620-00		----	78450-00	----
79175-02	Dual Purge - No Regulator	77367-00	78949-00	----	78450-00	----
79175-03	Single Purge W/Regulator	Kit #77620-00		79208-00	A-10456	75699-01
79175-04	Dual Purge W/Regulator	77367-00	78949-00	79208-00	A-10456	75699-01
79175-05	Single Purge - No Regulator Non-Electrostatic Spray	Kit #77620-00		----	A10969-00	----
79175-06	Dual Purge - No Regulator Non-Electrostatic Spray	77367-00	78949-00	----	A10969-00	----

<b>79175-XX MANIFOLD ASSEMBLY TABLE (Cont.)</b>						
<b>Part #</b>	<b>Description</b>	<b>"I"</b>	<b>"L"</b>	<b>"M"</b>	<b>"N"</b>	<b>"P"</b>
79175-01	Single Purge - No Regulator	----	1	1	1	79010-00
79175-02	Dual Purge - No Regulator	----	1	1	1	79010-00
79175-03	Single Purge W/Regulator	H-2382	2	2	2	79010-00
79175-04	Dual Purge W/Regulator	H-2382	2	2	2	79010-00
79175-05	Single Purge - No Regulator Non-Electrostatic Spray	----	1	1	1	----
79175-06	Dual Purge - No Regulator Non-Electrostatic Spray	----	1	1	1	----

**NOTES**

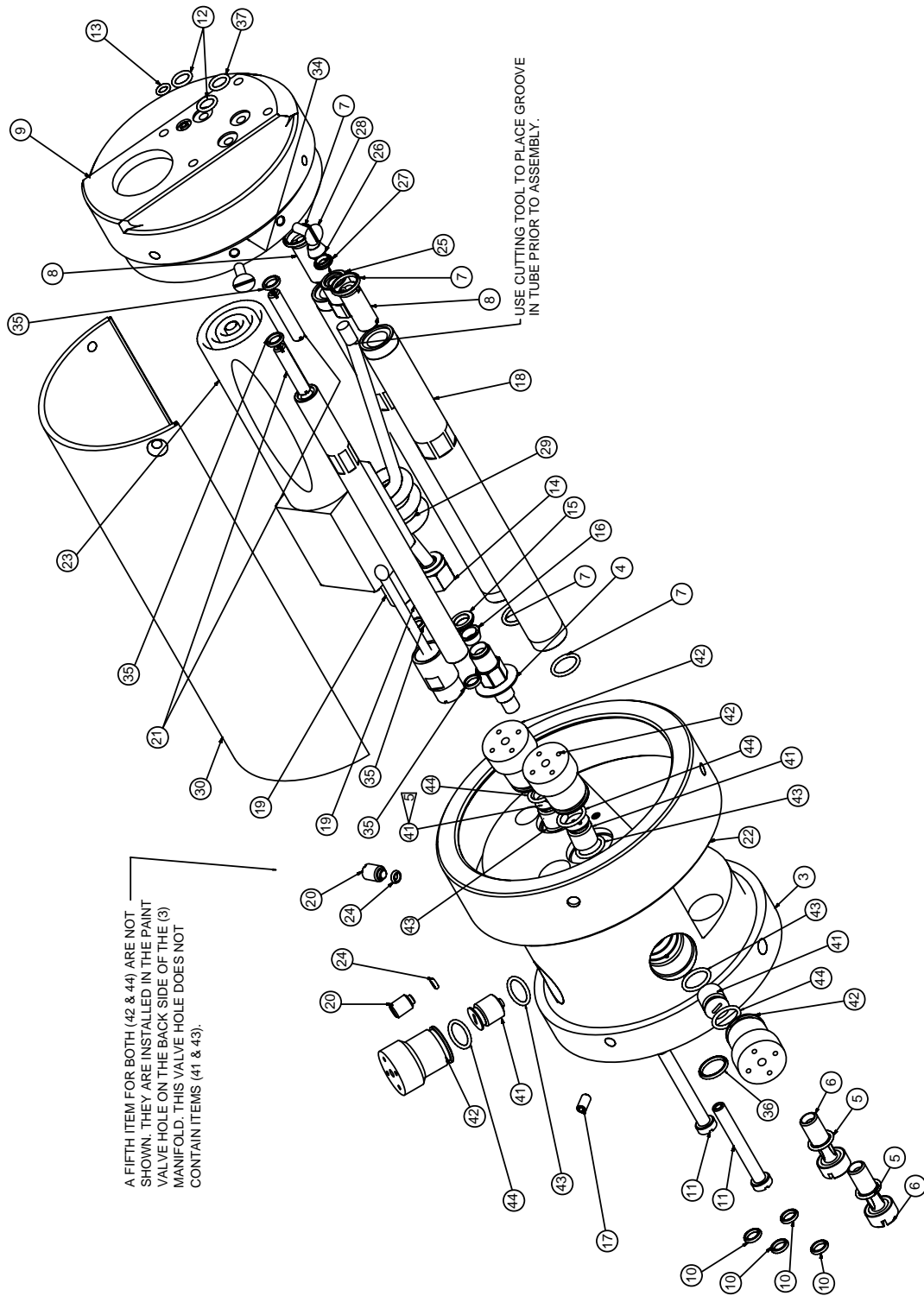

Figure 26: 79175-07 Manifold Assembly (Only)



<b>79175-07 MANIFOLD ASSEMBLY (ONLY) - PARTS LIST (Figure 26)</b>			
<b>Item #</b>	<b>Part #</b>	<b>Description</b>	<b>Qty</b>
1	----	----	--
2	----	----	--
3	79169-00	Assembly, Lower Manifold	1
4	79177-00	Assembly, Fluid Fitting	1
5	7554-10	O-Ring, Solvent Resistant	2
6	77508-00	Air Bolt, Machined	2
7	7554-11	O-Ring, Solvent Resistant	4
8	77509-00	Threaded Stud, Machined	2
9	79136-00	Manifold, Upper	1
10	79001-05	O-Ring, Solvent Proof	4
11	79160-00	Screw, Retaining, 1/4-20 X 2" Long, Stainless Steel	2
12	79001-06	O-Ring, Solvent Proof	2
13	79001-04	O-Ring, Solvent Proof	1
14	70591-01	Nut, Fluid Fitting, 1/4"	1
15	70606-01	Ferrule, Front 1/4" Tube	1
16	70607-01	Ferrule, Back 1/4" Tube	1
17	SSF-2052	Set Screw, 3/8" Long X 10-24	1
18	79134-00	Connecting Rod, Machined	2
19	79135-00	Tie Rod, Triggering	2
20	79170-00	Plug, Dump Line	2
21	79166-00	Connector, Air	2
22	79158-00	Retaining Ring	1
23	79010-00	Cascade Assembly, HP-404	1
24	79187-00	O-Ring, Teflon	2
25	78449-00	Fitting, Fluid	1
26	EMF-202-04	Ferrule, Back 1/4" Tube	1
27	EMF-203-04	Ferrule, Front 1/4" Tube	1
28	79161-00	Flat Head Slotted Screw, 10-32 X .5" Long	4
29	77531-00	Tube, Coiled, 1/4" OD X 1/8" ID	1
30	79157-00	Shroud, Matched Set	1
31	----	----	--
32	----	----	--
33	----	----	--
34	79209-00	O-Ring, Solvent Resistant	1
35	7554-07	O-Ring, Solvent Resistant	4
36	79001-09	O-Ring, Solvent Proof	1
37	79001-14	O-Ring, Solvent Proof	1
38	----	----	--
39	----	----	--
40	----	----	--
41	77618-00	Seat, Plug	4
42	79244-00	Valve, Plug	5
43	79001-14	O-Ring, Solvent Proof	4
44	79001-19	O-Ring, Solvent Proof	5

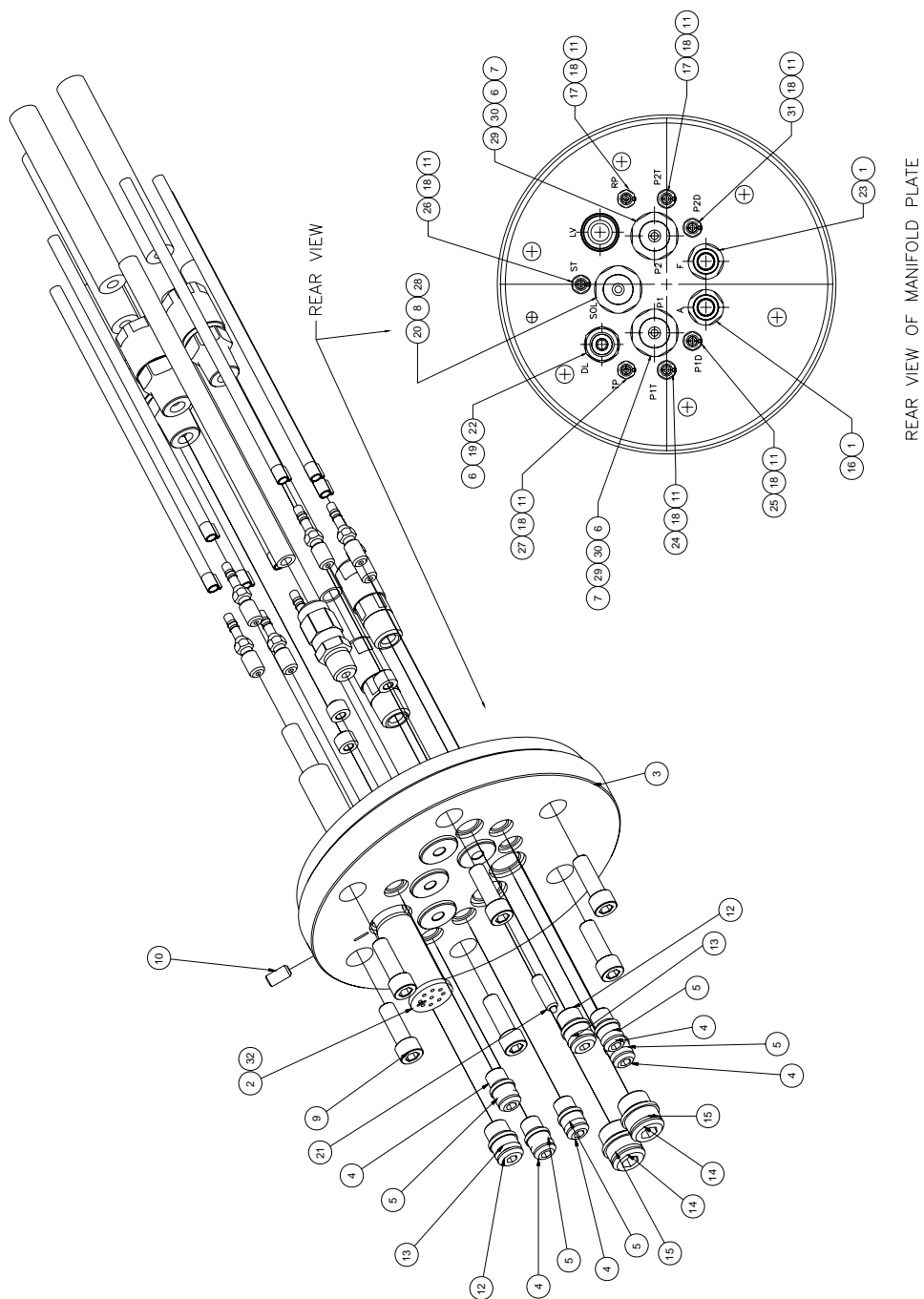

Figure 27a: 79156 Rear Tubing Manifold Assembly - English

**79156 REAR TUBING MANIFOLD ASSEMBLY PARTS LIST - ENGLISH (Figure 27a)**

Item #	Part #	Description	Qty
1	77947-00	Air Fitting, Modified	2
2	<b>Table CD - "Q"</b>	Low Voltage Cable Assembly	1
3	79155-00	Mounting Plate, Robot Machined	1
4	77507-00	Air Stud, Small Machined	<b>"S"</b>
5	79001-05	O-Ring, Solvent Proof	<b>"S"</b>
6	78308-00	Seal, Teflon	<b>"G"</b>
7	<b>Table A - "U"</b>	Fluid Fittings	<b>"P"</b>
8	78307-00	Nut, Fluid Fitting	1
9	76566-32C	Screw, 1/4-20 X 1" Long, SHCS	6
10	SSF-2052	Set Screw 3/8" Long X 10-24	1
11	EMF-82-1	Fitting, Air Pilot	<b>"H"</b>
12	77506-00	Air Stud, Medium Machined	<b>"T"</b>
13	79001-06	O-Ring, Solvent Proof	<b>"T"</b>
14	77505-00	Air Stud, Large Machined	2
15	79001-07	O-Ring, Solvent Proof	2
16	7113-04	Tubing, 3/8" OD X .05 Wall, Nylon	25 Ft.
17	SSP-5014	Tubing, 3/16" OD X .025 Wall, Nylon, Natural	<b>"L"</b>
18	77848-00	Clamp, Retaining	<b>"J"</b>
19	76698-02	Tubing, PFA .313 OD X .188 ID	25 Ft.
20	78306-01	Fluid Fitting, 3/16" ID	1
21	79191-00	Pin, Spring Loaded	1
22	79193-00	Fitting, 1/8 NPT X 5/16" ODT, Stainless Steel	1
23	79120-02	Tubing, 3/8" OD X .050 Wall, Nylon, Black	25 Ft.
24	79121-04	Tubing, 3/16" OD X .025 Wall, Nylon, Green	25 Ft.
25	79121-07	Tubing, 3/16" OD X .025 Wall, Nylon, Gray	25 Ft.
26	79121-05	Tubing, 3/16" OD X .025 Wall, Nylon, Blue	25 Ft.
27	79121-03	Tubing, 3/16" OD X .025 Wall, Nylon, Yellow	25 Ft.
28	72313-00	Hose, Shielded, 3/8" OD X .187 ID, Poly.	25 Ft.
29	<b>Table A - "E"</b>	Hose, Fluid	<b>"N"</b>
30	<b>Table A - "F"</b>	Nut, Fluid Fitting	<b>"P"</b>
31	79121-06	Tubing, 3/16" OD X .025 Wall, Nylon, Black	<b>"M"</b>
32	<b>Table CD - "R"</b>	Low Voltage Cable, HP-404 Extension	1

<b>TABLE A - HOSE STYLE (ENGLISH)</b>				
Dash No.	Description	"E"	"F"	"U"
0	No Fluid Hose	----	----	----
1	3/16" ID X 5/16" OD, Non-Shielded 3/16"	76698-02	79195-00	78306-01
2	3/16" ID X 3/8 OD, (Inner Tube), Shielded Hose	74178-02	78307-00	78306-01
3	3/16" ID X 3/8" OD Non-Shielded Hose	76698-04	A10401-00	78306-02
4	1/4" ID X 3/8" OD, (Inner Tube), Shielded Hose	74178-01	78307-00	78306-02
5	6mm ID X 10mm OD Non-Shielded Hose	A10841-02	----	----

<b>TABLE B - MANIFOLD TYPE (ENGLISH)</b>										
Dash No.	Description	"G"	"H"	"J"	"L"	"M"	"N"	"P"	"S"	"T"
0	Single Purge - No Regulator	2	4	4	----	----	25 Ft.	1	3	1
1	Double Purge - No Regulator	3	6	6	25 Ft.	25 Ft.	50 Ft.	2	5	1
2	Single Purge W/Regulator	2	5	5	25 Ft.	0 Ft.	25 Ft.	1	3	2
3	Double Purge W/Regulator	3	7	7	50 Ft.	25 Ft.	50 Ft.	2	5	2

<b>TABLE CD - CABLE COMBINATION (ENGLISH)</b>			
Dash No.	Description	"Q"	"R"
00	No Cable	----	----
<b>W/LECU5004-XX Power Supply Cable</b>			
01	25' One-Piece Cable	79008-25	----
02	50' One-Piece Cable	79008-50	----
03	75' One-Piece Cable	79008-75	----
04	100' One-Piece Cable	79008-100	----
05	15' Robot to Junction Box; 15' Junction Box to MicroPak	79008-15J	77062-15
06	15' Robot to Junction Box; 40' Junction Box to MicroPak	79008-15J	77062-40
07	15' Robot to Junction Box; 60' Junction Box to MicroPak	79008-15J	77062-60
08	15' Robot to Junction Box; 75' Junction Box to MicroPak	79008-15J	77062-75
09	25' Robot to Junction Box; 25' Junction Box to MicroPak	79008-25J	77062-25
10	25' Robot to Junction Box; 50' Junction Box to MicroPak	79008-25J	77062-50
11	25' Robot to Junction Box; 75' Junction Box to MicroPak	79008-25J	77062-75
<b>W/A10406-XX Power Supply Cable</b>			
31	25' One-Piece Cable	A11353-25	----
32	50' One-Piece Cable	A11353-50	----
33	75' One-Piece Cable	A11353-75	----
34	100' One-Piece Cable	A11353-100	----
35	15' Robot to Junction Box; 15' Junction Box to MicroPak	A11355-15	A11356-15
36	15' Robot to Junction Box; 40' Junction Box to MicroPak	A11355-15	A11356-40
37	15' Robot to Junction Box; 60' Junction Box to MicroPak	A11355-15	A11356-60
38	15' Robot to Junction Box; 75' Junction Box to MicroPak	A11355-15	A11356-75
39	25' Robot to Junction Box; 25' Junction Box to MicroPak	A11355-25	A11356-25
40	25' Robot to Junction Box; 50' Junction Box to MicroPak	A11355-25	A11356-50
41	25' Robot to Junction Box; 75' Junction Box to MicroPak	A11355-25	A11356-75

(For 79156 Rear Tubing Manifold Assembly - English, See Figure 27a.)

**CAUTION**

▶ DO NOT over-tighten the 77544-01 (11) beyond the maximum 10 in•lbs force.

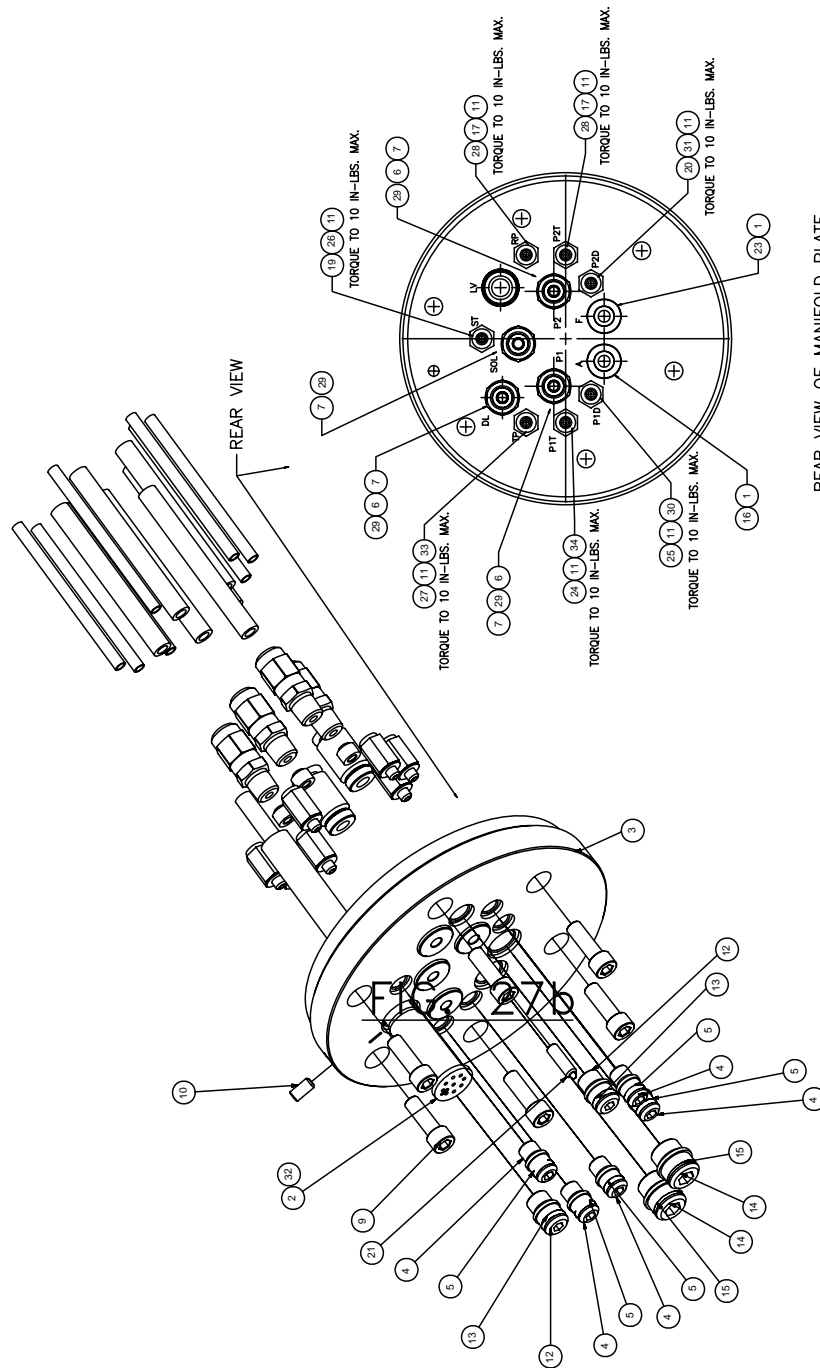

Figure 27b: A10853 Rear Tubing Manifold Assembly - Metric

**A10853 REAR TUBING MANIFOLD ASSEMBLY - PARTS LIST METRIC (Figure 27b)**

Item #	Part #	Description	Qty
1	79579-00	Fitting, Male Connector, 1/4" X 10mm X 8mm Tube	2
2	<b>Table CD - "Q"</b>	Low Voltage Cable Assembly	1
3	A10975-00	Mounting Plate (Metric)	1
4	77507-00	Air Stud, Small Machined	<b>"S"</b>
5	79001-05	O-Ring, Solvent Proof	<b>"S"</b>
6	78308-00	Seal, Teflon	<b>"G"</b>
7	A10854-00	Hose Connection, 1/8" X 8mm X 6mm Tube	<b>"P"</b>
8	----	----	-
9	79566-32C	Screw, 1/4-20 X 1" Lg., SHCS	6
10	SSF-2052	Set Screw, 3/8" Lg. X 10-24	1
11	77544-01	Male Connector, 4mm OD Tube X 10-32 Threaded	<b>"H"</b>
12	77506-00	Air Stud, Medium Machined	<b>"T"</b>
13	79001-06	O-Ring, Solvent Proof	<b>"T"</b>
14	77505-00	Air Stud, Large Machined	2
15	79001-07	O-Ring, Solvent Proof	2
16	A10839-10	Tubing, 10mm OD X 8mm ID, Nylon, Natural	7.62m
17	77536-05	Tubing, 4mm OD X .106" ID, Nylon, Natural	<b>"L"</b>
19	77545-01	Cap, Fitting Identification, 4mm OD, Blue	1
20	77545-02	Cap, Fitting Identification, 4mm OD, Black	1
21	79191-00	Pin, Spring Loaded	1
23	A10839-01	Tubing, 10mm OD X 8mm ID, Nylon, Black	7.62m
24	77536-03	Tubing, 4mm OD X .106" ID, Nylon, Green	7.62m
25	77536-06	Tubing, 4mm OD X .106" ID, Nylon, Silver	7.62m
26	77536-04	Tubing, 4mm OD X .106" ID, Nylon, Blue	7.62m
27	77536-07	Tubing, 4mm OD X .106" ID, Nylon, Yellow	7.62m
28	77545-04	Cap, Fitting Identification, 5/32" (4mm) OD, Natural	2
29	<b>Table A - "E"</b>	Tubing, 8mm OD X 6mm ID, PFA, Natural	<b>"N"</b>
30	77545-05	Cap, Fitting Identification, 4mm OD, Natural	1
31	77536-01	Tubing, 4mm OD X .106" ID, Nylon, Black	<b>"M"</b>
32	<b>Table CD - "R"</b>	Low Voltage Cable, HP404 Extension	1
33	77545-12	Cap, Fitting Identification, 4mm OD, Yellow	1
34	77545-03	Cap, Fitting Identification, 4mm OD, Green	1

<b>TABLE A - HOSE STYLE (METRIC)</b>		
Dash No.	Description	"E"
0	No Fluid Hose	----
1	6mm I.D. X 8mm OD Non-Shielded Hose	A10841-02

<b>TABLE B - MANIFOLD TYPE (METRIC)</b>											
Dash No.	Description	"G"	"H"	"L"	"M"	"N"	"P"	"S"	"T"	"U"	"V"
0	Single Purge - No Regulator	2	4	----	----	22.86m	3	3	1	0	0
1	Double Purge - No Regulator	3	6	7.62m	7.62	30.48m	4	5	1	1	1
2	Single Purge W/Regulator	2	5	7.62m	----	22.86m	3	3	2	0	1
3	Double Purge W/Regulator	3	7	15.24m	7.62	30.48m	4	5	2	1	2

<b>TABLE CD - CABLE COMBINATION (METRIC)</b>			
Dash No.	Description	"Q"	"R"
00	No Cable	----	----
<b>W/LECU5004-XX Power Supply Cable</b>			
01	7.6m One-Piece Cable	79008-25	----
02	15.2m One-Piece Cable	79008-50	----
03	22.9m One-Piece Cable	79008-75	----
04	30.5m One-Piece Cable	79008-100	----
05	4.6m Robot to Junction Box; 4.6m Junction Box to MicroPak	79008-15J	77062-15
06	4.6m Robot to Junction Box; 12.2m Junction Box to MicroPak	79008-15J	77062-40
07	4.6m Robot to Junction Box; 18.3m Junction Box to MicroPak	79008-15J	77062-60
08	4.6m Robot to Junction Box; 22.9m Junction Box to MicroPak	79008-15J	77062-75
09	7.6m Robot to Junction Box; 7.6m Junction Box to MicroPak	79008-25J	77062-25
10	7.6m Robot to Junction Box; 15.2m Junction Box to MicroPak	79008-25J	77062-50
11	7.6m Robot to Junction Box; 22.9m Junction Box to MicroPak	79008-25J	77062-75
<b>W/A10406-XX Power Supply Cable</b>			
31	7.6m One-Piece Cable	A11353-25	----
32	15.2m One-Piece Cable	A11353-50	----
33	22.9m One-Piece Cable	A11353-75	----
34	30.5m One-Piece Cable	A11353-100	----
35	4.6m Robot to Junction Box; 4.6m Junction Box to MicroPak	A11355-15	A11356-15
36	4.6m Robot to Junction Box; 12.2m Junction Box to MicroPak	A11355-15	A11356-40
37	4.6m Robot to Junction Box; 18.3m Junction Box to MicroPak	A11355-15	A11356-60
38	4.6m Robot to Junction Box; 22.9m Junction Box to MicroPak	A11355-15	A11356-75
39	7.6m Robot to Junction Box; 7.6m Junction Box to MicroPak	A11355-25	A11356-25
40	7.6m Robot to Junction Box; 15.2m Junction Box to MicroPak	A11355-25	A11356-50
41	7.6m Robot to Junction Box; 22.9m Junction Box to MicroPak	A11355-25	A11356-75

(For A10853 Rear Tubing Manifold Assembly - Metric, See Figure 27b.)

**SIGNAL IDENTIFICATION TABLE - ENGLISH**

Abbr.	Description	Color	Tubing Material	Tubing Size	Item #
P1	Paint #1	Clear	Teflon	5/16" OD X 3/16" ID	29
P2	Paint #2	Black	Urethane/Poly/Teflon	5/16" OD X 3/16" ID	29
P1	Paint #1	Clear	Teflon	3/8" OD X 1/4" ID	29
P2	Paint #2	Black	Urethane/Poly/Teflon	3/8" OD X 1/4" ID	29
SOL	Solvent	Black	Urethane/Poly	3/8" OD X .187" ID	28
P1T	Paint #1 Trigger	Green	Nylon	3/16" OD X .050" Wall	24
P1D	Paint #1 Dump	Gray	Nylon	3/16" OD X .050" Wall	25
P2T	Paint #2 Trigger	Natural	Nylon	3/16" OD X .050" Wall	17
P2D	Paint #2 Dump	Black	Nylon	3/16" OD X .050" Wall	31
TP	Trigger Pilot	Black	Nylon	3/16" OD X .050" Wall	27
DL	Dump Line	Natural	Teflon	.313" OD X .188" ID	19
RP	Regulator Pilot	Natural	Nylon	3/16" OD X .050" Wall	17
ST	Solvent Trigger	Blue	Nylon	3/16" OD X .050" Wall	26
F	Fan Air	Black	Nylon	3/8" OD X .250" ID	23
A	Atomization Air	Natural	Nylon	3/8" OD X .250" ID	16
LV	Low Voltage Cable	Black	N/A	N/A	2, 32

**SIGNAL IDENTIFICATION TABLE - METRIC**

Abbr.	Description	Color	Tubing Material	Tubing Size	Item #
P1	Paint #1	Clear	Teflon	8mm OD X 6mm ID	29
P2	Paint #2	Clear	Teflon	8mm OD X 6mm ID	29
SOL	Solvent	Clear	Teflon	8mm OD X 6mm ID	29
P1T	Paint #1 Trigger	Green	Nylon	4mm OD X .106" ID	24
P1D	Paint #1 Dump	Silver	Nylon	4mm OD X .106" ID	25
P2T	Paint #2 Trigger	Natural	Nylon	4mm OD X .106" ID	17
P2D	Paint #2 Dump	Black	Nylon	4mm OD X .106" ID	31
TP	Trigger Pilot	Yellow	Nylon	4mm OD X .106" ID	27
DL	Dump Line	Clear	Teflon	8mm OD X 6mm ID	29
RP	Regulator Pilot	Natural	Nylon	4mm OD X .106" ID	17
ST	Solvent Trigger	Blue	Nylon	4mm OD X .106" ID	26
F	Fan Air	Black	Nylon	10mm OD X 8mm ID	23
A	Atomization Air	Natural	Nylon	10mm OD X 8mm ID	16
LV	Low Voltage Cable	Black	N/A	N/A	2, 32



<b>SERVICE PARTS</b>						
<b>Part #</b>	<b>Description</b>	<b>Number of Guns</b>				<b>Notes</b>
		<b>1-2</b>	<b>3-4</b>	<b>5-6</b>	<b>7-8</b>	
79138-00	Complete Head Assembly	1	2	2	3	
79153-65R-1	Air Cap	1	2	3	4	79196-98-1, 79197-63-1 (Optional Air Caps)
79140-02	Fluid Tip	1	2	3	4	01=.042,03=.070 (Optional Fluid Tips)
70430-01	Electrode	1	2	3	4	
79142-00	Screw	2	2	4	4	
79171-00	Spring, Connector	2	2	4	4	
79141-00	Plug, Connection	2	2	4	4	
14061-09	Conductive Foam	1	1	2	2	
79144-00	Shaft, Air Valve	1	1	2	2	
79143-00	Bushing, Air Valve	1	1	2	2	
79173-00	Block, Locking	2	2	4	4	
79174-00	Screw	1	1	2	2	
77367-00	Seat Assembly	1	1	2	2	

<b>REPAIR KITS</b>						
<b>Part #</b>	<b>Description</b>	<b>Number of Guns</b>				<b>Notes</b>
		<b>1-2</b>	<b>3-4</b>	<b>5-6</b>	<b>7-8</b>	
A10407	Robot Mounting Plate O-Ring Kit	1	2	3	4	Includes: 9 ea. - 79001-05 O-Ring (Solvent Proof) 2 ea. - 79001-06 O-Ring (Solvent Proof) 2 ea. - 79001-07 O-Ring (Solvent Proof) 1 ea. - 79001-01 O-Ring (Solvent Proof)
A10408	Manifold Assembly O-Ring Kit	1	2	3	4	Includes: 2 ea. - 7554-10 O-Ring (Solvent Resistant) 4 ea. - 7554-11 O-Ring (Solvent Resistant) 4 ea. - 79001-05 O-Ring (Solvent Proof) 2 ea. - 79001-06 O-Ring (Solvent Proof) 1 ea. - 79001-04 O-Ring (Solvent Proof) 1 ea. - 79209-00 O-Ring (Solvent Resistant) 4 ea. - 7554-07 O-Ring (Solvent Resistant) 1 ea. - 79001-09 O-Ring (Solvent Proof) 1 ea. - 79001-14 O-Ring (Solvent Proof)
A10409	Regulator Repair Kit	1	2	2	3	If gun is equipped with 79208-00 Regulator it Includes: 1 ea. - 79220-00 Diaphragm 1 ea. - 74161-00 Spring 1 ea. - 77354-00 Needle & Seat 1 ea. - 79001-08 O-Ring (Solvent Proof)
A10410	Spray Head Mounting Seal O-Ring Kit	1	2	3	4	Includes: 1 ea. - 79001-04 O-Ring (Solvent Proof) 2 ea. - 79001-06 O-Ring (Solvent Proof) 1 ea. - 79001-05 O-Ring (Solvent Proof)

(Continued On Next Page)

<b>REPAIR KITS (Cont.)</b>						
<b>Part #</b>	<b>Description</b>	<b>Number of Guns</b>				<b>Notes</b>
		<b>1-2</b>	<b>3-4</b>	<b>5-6</b>	<b>7-8</b>	
A10411	Spray Head Repair Kit	1	2	3	4	Includes: 1 ea. - 79151-00 Needle Shaft 1 ea. - 7723-06 Piston, U-Cup 1 ea. - 79001-28 O-Ring (Solvent Proof) 1 ea. - 79001-29 O-Ring (Solvent Proof) 3 ea. - 79001-01 O-Ring (Solvent Proof) 1 ea. - 13076-13 O-Ring (Teflon) 1 ea. - 79001-06 O-Ring (Solvent Proof) 1 ea. - RME-38 Spring 1 ea. - RME-32 Seal 1 ea. - 79001-01 O-Ring (Solvent Proof) 1 ea. - 79001-04 O-Ring (Solvent Proof) 2 ea. - 79001-06 O-Ring (Solvent Proof) 1 ea. - 79001-05 O-Ring (Solvent Proof) 2 ea. - 14061-09 Conductive Foam 1 ea. - 79171-00 Contact Spring

---

# WARRANTY POLICIES

---

## LIMITED WARRANTY

ITW Ransburg will replace or repair without charge any part and/or equipment that fails within the specified time (see below) because of faulty workmanship or material, provided that the equipment has been used and maintained in accordance with ITW Ransburg's written safety and operating instructions, and has been used under normal operating conditions. Normal wear items are excluded.

### **THE USE OF OTHER THAN ITW RANSBURG APPROVED PARTS VOIDS ALL WARRANTIES.**

**SPARE PARTS:** One hundred and eighty (180) days from date of purchase, except for rebuilt parts (any part number ending in "R") for which the warranty period is ninety (90) days.

**EQUIPMENT:** When purchased as a complete unit, (i.e., guns, power supplies, control units, etc.), is one (1) year from date of purchase.  
**WRAPPING THE APPLICATOR IN PLASTIC WILL VOID THIS WARRANTY.**

**ITW RANSBURG'S ONLY OBLIGATION UNDER THIS WARRANTY IS TO REPLACE PARTS THAT HAVE FAILED BECAUSE OF FAULTY WORKMANSHIP OR MATERIALS. THERE ARE NO IMPLIED WARRANTIES NOR WARRANTIES OF EITHER MERCHANTABILITY OR FITNESS FOR A PARTICULAR PURPOSE. ITW RANSBURG ASSUMES NO LIABILITY FOR INJURY, DAMAGE TO PROPERTY OR FOR CONSEQUENTIAL DAMAGES FOR LOSS OF GOODWILL OR PRODUCTION OR INCOME, WHICH RESULT FROM USE OR MISUSE OF THE EQUIPMENT BY PURCHASER OR OTHERS.**

### **EXCLUSIONS:**

If, in ITW Ransburg's opinion the warranty item in question, or other items damaged by this part was improperly installed, operated or maintained, Ransburg will assume no responsibility for repair or replacement of the item or items. The purchaser, therefore will assume all responsibility for any cost of repair or replacement and service related costs if applicable.

## MANUAL CHANGE SUMMARY

This manual was published to supercede Service Manual **AA-03-02.9 Evolver Solventborne Robotic Atomizers** to make the following changes:

1. New "Figure 26 - 79175-07 Manifold Assembly (Only)" in the "Parts Identification" section.
2. Revised "79175-07 Manifold Assembly (Only) Parts List - Items #43 and 44 - Part #" in the "Parts Identification" section.
3. Added "Euro" to the "Front Cover" and "Back Page".

**Service Manual Price: €40.00 (Euro)  
\$50.00 (U.S.)**

---

### **Manufacturing**

1910 North Wayne Street  
Angola, Indiana 46703-9100  
Telephone: 260/665-8800  
Fax: 260/665-8516

### **Technical/Service Assistance**

Automotive Assembly and Tier I  
Industrial Systems  
Ransburg Guns

Telephone: 800/ 626-3565    Fax: 419/ 470-2040  
Telephone: 800/ 233-3366    Fax: 419/ 470-2071  
Telephone: 800/ 233-3366    Fax: 419/ 470-2071

**Technical Support Representative will direct you to the appropriate telephone number for ordering Spare Parts.**

