

# SERVICE MANUAL for *Aprilaire*® HUMIDIFIER

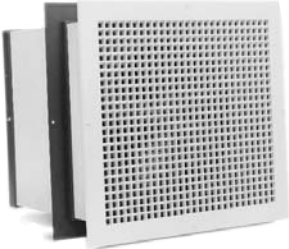

**This Service Manual is divided into two sections.  
The first section is general service common to all residential models.  
The second section is specific service required on individual models.**

## **GENERAL SERVICE**

**PAGE**

Lack of Humidity .....	2
Excess Humidity .....	4
Leaking Water .....	4
Noise .....	4
General Maintenance .....	4

## **INDIVIDUAL UNIT SERVICE**

Models 220-224-400*-440-550-550A*-558*-560-560A*-568*-600* ...	6
Models 760,760A* & 700* (formerly model 768*) .....	13
Models 445,445A* & 448* .....	16
Model 350, 360 .....	19
Models 110 & 112.....	22

\*Units featuring the Aprilaire Humidifier Control

# GENERAL SERVICE

## **WARNING:**

1. 120 VOLTS may cause serious injury from electrical shock on Models 110, 112, 350, 360, 445, 445A, 448, 760, 760A and 700 (Formerly model 768) humidifiers. Disconnect power and shut off water supply before servicing or troubleshooting these units.
2. Rotating or electrical components may cause serious injury from contact. Keep hands and face clear when checking operation.
3. Hot water temperatures in excess of 125°F may cause burns.

## **CAUTION:**

1. Sudden operation may cause personal injury or property damage on Models 220, 224, 400, 440, 550, 550A, 558, 560, 560A, 568 and 600 humidifiers. Turn the Humidifier Control or manual humidistat to “Off” or lowest setting before servicing or troubleshooting these units.

## I. LACK OF HUMIDITY (All Units)

### Check Relative Humidity Level In The Home

#### **Aprilaire Humidifier Control – Automatic Mode**

- The Aprilaire Humidifier Control supplied with the Aprilaire Automatic Humidifier can be used to measure the relative humidity (RH) in the home. To determine the relative humidity in the home, follow these steps:
  1. Determine the outdoor temperature.
  2. Activate the furnace blower by setting your thermostat fan switch to the “On” position, or by setting your thermostat to a higher temperature.
  3. Turn the control dial setting to the “Off” position. Then, slowly turn the dial clockwise until you hear the control “click ON”. Next, slowly turn the dial counterclockwise until you hear the control “click OFF”. At this point, make note of the dial setting.
  4. Locate your dial setting on Table 2. Follow the dial setting to the right until it intersects with the current outdoor temperature. This is the relative humidity in your home under existing conditions.

**(Table 2) % Relative Humidity Guide**

		Outdoor Temperature (°F)					
		-10	0	10	20	30	40
Dial Setting	1	10	10	10	15	20	25
	2	10	10	15	20	25	30
	3	10	15	20	25	30	35
	4	15	20	25	30	35	40
	5	20	25	30	35	40	45
	6	25	30	35	40	45	45
	7	30	35	40	45	45	45

Relative Humidity (%)

*As an example, if the outdoor temperature is 20° F and, following step 3, the humidifier turns OFF at “5” on the dial range, then the relative humidity in your home is 35%.*

5. Return the thermostat and Humidifier Control to their original settings.

#### **Aprilaire Humidifier Control – Manual Mode**

- Follow steps 2 – 3, the point at which the solenoid valve opens is the humidity level in your home.

#### **Manual Humidistat**

- The manual humidistat supplied with the Aprilaire® Humidifier is an accurate gauge that can be used to measure the relative humidity in the home. Turn the humidistat dial to the lowest setting. Slowly increase the setting until a light click is heard. The relative humidity in the home will be very close to the reading at this point.

**Check Windows, Fans and Fireplaces** — IT IS IMPORTANT THAT THE HOUSE BE CHECKED FOR OPEN WINDOWS, EXHAUST FANS, AND FIREPLACE DAMPERS. They provide an excellent escape route for heat, as well as humidity. Humidity is lost at an even faster rate than heat because water vapor tends to seek its own level and your humidifier would not be able to replace it even when running at full capacity.

**Size Unit to House** — The size home that can be satisfactorily humidified is determined by the amount of outside air infiltration. The Air Conditioning, Refrigeration Institute (ARI) recommends that home construction be classified in three general categories: loose, average, tight.

The Loose House — 2 air changes per hour.

The Average House — 1 air change per hour.

The Tight House — 1/2 air change per hour.

Listed below is the square footage that each unit is designed to handle:

<b>Chart A</b>	<b>Model</b>	<b>Model</b>	<b>Model</b>	<b>Model</b>	<b>Model</b>
<b>Square Feet Capacity *</b>	<b>760<sup>0</sup>/760A<sup>0</sup>/768<sup>0</sup>/700<sup>0</sup></b>	<b>110<sup>0</sup></b>	<b>112<sup>0</sup></b>	<b>350<sup>0</sup>/360<sup>0</sup></b>	<b>400<sup>0</sup>/560<sup>0</sup>/560A<sup>0</sup>/568<sup>0</sup>/600<sup>0</sup></b>
Loose House	1,050	800	1,150	1,100	1,000
Average House	2,100	1,600	2,350	2,250	2,100
Tight House	4,200	3,250	4,750	4,500	4,200

<b>Chart B</b>	<b>Model</b>	<b>Model</b>	<b>Model</b>	<b>Model</b>	<b>Model</b>
<b>Square Feet Capacity *</b>	<b>220<sup>0</sup></b>	<b>224<sup>0</sup></b>	<b>440<sup>0</sup></b>	<b>445<sup>0</sup>/445A/448</b>	<b>550<sup>0</sup>/550A<sup>0</sup>/558<sup>0</sup></b>
Loose House	600	1,000	1,000	1,000	750
Average House	1,250	2,100	2,100	2,100	1,500
Tight House	2,500	4,200	4,200	4,200	3,000

\*Based on 8' ceiling height.

**Models 220, 224, 400, 440, 445, 445A, 448, 550, 550A, 558, 560, 560A, 568 and 600**  
 Total Static Pressure Drop Across Supply & Return Plenum .....0.2"

- |  |   |
|--|---|
| (1) Calculations are based on:<br>a. 120°F Plenum Temperature<br>b. 70°F and 35% R.H. Indoor Air<br>c. 20°F and 70% R.H. Outdoor Air<br>d. Internal Moisture Gain = 1 lb/hr.<br>e. 70% Blower Operation<br>f. 55°F Service Water Temperature | (2) Calculations are based on:<br>a. 70°F and 35% R.H. Indoor Air<br>b. 20°F and 70% R.H. Outdoor Air<br>c. Internal Moisture Gain = 1 lb/hr.<br>d. 140°F Service Water Temp. @ 6 GPH<br>e. Continuous Operation at 150 CFM |
|--|---|

**Recommended Settings** — It is recommended that the temperature-humidity table noted below be followed. Square feet capacities are based on these settings

<u>OUTSIDE TEMPERATURE</u>	<u>RECOMMENDED HUMIDITY</u>
+40°F .....	.45%
+30°F .....	.40%
+20°F .....	.35%
+10°F .....	.30%
0°F .....	.25%
-10°F .....	.20%
-20°F .....	.15%

Excess humidity may result in condensation on doors, windows, inside of outer walls, and on other exposed surfaces. If this exists, reduce the setting on the Control.

**Furnace Operation** — Plenum mounted humidifiers are dependent upon heat for evaporation and normally extract this heat directly from the hot air in the supply plenum. With self-contained units or power units applied to the return air plenum, heat required for the evaporation process can be obtained directly from service hot water.

Lack of humidity complaints can often times be traced to oversized furnaces where the burner is on only for a short period of time. With installations such as these, it is our recommendation that the furnace blower be adjusted for longer operation or the blower be operated continually off the manual setting so the humidifier can function over a longer period of time to satisfy the humidistat. In many installations, the water supply may be switched from cold water to service hot water to supply the necessary heat required in the evaporation process. This has also been a suggestion when the sizing for the humidifier is marginal.

**Multi-Speed Furnace Blower Motors** — Furnaces with a multi-speed blower may damage the humidifier. Premature component failure may result when interfacing Aprilaire Humidifiers with furnaces having multi-speed direct drive motors or having other than 120VAC. Use the RP Model 50 Current Sensing Relay.

**Low Voltage** — Disconnect electrical power. Check for low voltage in the house and at the unit itself.

## II. EXCESS HUMIDITY

### Humidity Control Check —

**Check Wiring** — A closed short in the low voltage control circuit leading to the humidistat may cause the unit to run continually.

**Check Relay/120 Volt Humidifier Control** — A defective or sticking contact on the relay or a defective 120 Volt humidifier control (Models 110, 112, 330, 350, 360, 445, 448, 760, 768 or 700) may cause the unit to run continually.

**Electrical Components** — Failure of any electrical component in the humidifier may cause the humidifier to run continually, if stuck in the operating position. Examination with a neon light tester or an appropriate testing instrument will help locate which electrical component is malfunctioning.

## III. LEAKING WATER (All Units Except Models 400, 445, 445A & 448)

**Water Backing Up Drain Line** — If the drain line does not have a continuous slope to the drain, it is possible for it to air lock and for water to back up in the drain line. A drain safety overflow has been molded into the lower housing of all the black plastic Aprilaire units. This safety overflow is designed to eliminate water inside of the furnace plenum if there is a malfunction. Removing dips and hills from the drain line and flushing it with water under pressure will eliminate the problem. Replace drain line every year or as necessary.

**Water Panel Evaporator & Scale Control Insert** — A clogged Water Panel evaporator could cause the scale control insert to fill with residue and block the drain opening, causing leaking. Clean scale control insert and install a new Water Panel® evaporator.

**Solenoid Valve** — Be sure that the water flow through the valve is in the correct direction. Note an arrow designating water flow direction on the valve bodies. Should a piece of dirt lodge between the valve plunger and seat on the solenoid and prevent it from fully closing, the solenoid will leak. After shutting off the water at the saddle valve, disconnect electrical power, remove the solenoid and backwash with water under light pressure or blow out. This is quite effective unless the valve seat has been permanently damaged, in which case, it will be necessary to replace the entire solenoid valve.

**Water Pressure** — Water pressure above 125 psi can cause leakage. Check pressure and use a pressure reducer if necessary.

## IV. NOISE

**Solenoid Valve** — There will be a "click" each time the valve opens and closes. A light gauge plenum will amplify this noise. If the unit is not snug against the plenum, the noise is increased. If water hammer is a problem, a length of high pressure hose installed before the valve, acts as a cushion to reduce the noise. **Check local codes before using plastic hose.**

## V. GENERAL MAINTENANCE

**Water Panel® Evaporation Check** — When the openings become clogged and restrict the air-flow through the panel, it should be replaced. The life of the Water Panel evaporator will vary with the hardness of the water, the amount of use, and the application. It is recommended that the Water Panel be changed at least once every year (twice a year for Model 400). Replace with only genuine RP Water Panels for continued peak efficiency and overall performance. The Water Panel evaporator will be most efficient when installed with the colored spot at the top, if present. Make sure the entire Water Panel is enclosed in the scale control insert.

**Evaporation Check** — The evaporative capacity of the Aprilaire humidifiers (excluding the models 400, 445 & 448) can be checked by determining the time it takes to fill a quart jar from the water supply and the drain. The following formula can be used to determine the evaporation of the unit on an hourly basis.

$$\frac{\text{lb}}{\text{hr}} = \frac{7509}{\text{seconds to fill quart jar}}$$

The constant 7509 is obtained by multiplying the seconds per hour (3600) times the weight of one quart of water (2.086 lbs.) Subtract the result of the supply water check from the result of the drain water check. The answer is the pounds of water evaporated per hour. To convert pounds of water to gallons of water, divide by 8.343.

**EXAMPLE:** The supply water line fills the quart jar in 2 min. 30 sec. or 150 sec. 7,509 divided by 150 = 50.1 lbs./hr. The quart jar was filled with water from the drain in 2 min. 50 sec. or 170 sec. 7,509 divided by 170 = 44.2 lb./hr. The difference between 50.1 lb./hr. and 44.2 lb./hr. is 5.9 lb./hr. This calculates out to 0.7 gals. per hour.

$\frac{1 \text{ qt.}}{150 \text{ sec.}} = \frac{2.086 \text{ lbs.}}{\text{qt.}} = \frac{3600 \text{ sec.}}{\text{hr.}} = \frac{7509}{150} = 50.1 \text{ lbs./hr.}$	$\frac{50.1 \text{ lbs./hr.}}{-44.2 \text{ lbs./hr.}} = 5.9 \text{ lbs./hr.}$
$\frac{1 \text{ qt.}}{170 \text{ sec.}} = \frac{2.086 \text{ lbs.}}{\text{qt.}} = \frac{3600 \text{ sec.}}{\text{hr.}} = \frac{7509}{170} = 44.2 \text{ lbs./hr.}$	

Prior to making an evaporation check on an Aprilaire furnace mounted humidifier, set the thermostat and humidistat so that the furnace and humidifier will run without cycling for at least 5 minutes. Allow the humidifier to operate for a minimum of 2 minutes before checking the time to fill the quart jar at the supply and drain.

The design feed rate is 3 gph for the Models 110, 220, 550, 550A, 558, 560, 560A, 568 and 600. This feed rate will fill a quart jar in 5 minutes. The design feed rate for the Models 112, 224, 330, 350, 360, 440, 760, 760A, 768 and 700 is 6 gph. This feed rate will fill a quart jar in 2-1/2 minutes.

The Aprilaire furnace mounted humidifiers must have an average air temperature of 120°F to evaporate rated capacity.

The water temperature of the Model 330, 350 & 360 must be 140°F when checking evaporation rate.

**EVAPORATIVE CAPACITY**

<b>Model 760, 760A, 768 &amp; 700</b>	<b>Model 110</b>	<b>Model 112</b>	<b>Model 350 &amp; 360</b>
0.75 gals. water/hr at 120°F plenum temperature	0.55 gals. water/hr at 120°F plenum temperature	0.85 gals. water/hr at 120°F plenum temperature	0.5 gals. water/hr at 140°F service hot water

**MODELS 220, 224, 440, 445, 448, 550, 558, 560, 568, & 600 EVAPORATIVE CAPACITY**  
at 120°F Plenum Temperature

Total Static Pressure Drop Across Supply & Return Plenum	.02"
Models 550,550A & 558	.050 gph
Models 400,560,560A, 568 & 600	.070 gph
Models 445,445A & 448	.075 gph
Model 220	.040 gph
Models 224, 440	.070 gph

**Level Unit** — The unit or distribution tray **must be level** so that the water will be evenly distributed over the entire width of the Water Panel evaporator. If the full width of the Water Panel evaporator is not wetted, the capacity will be reduced.

**Water Feed System (All Units Except Models 445, 445A, & 448)** — The water supply starts from a saddle valve attached to a water pipe. The valve should be completely open. Water flows to the unit through a 1/4" copper tube to a solenoid valve equipped with an in-line water strainer. The valve electrically opens and closes to control the supply of water, and the strainer filters particles from the water. Filtered water then goes through the orifice which meters the water through the 1/4" tube to the distribution tray. From the distribution tray, water flows by gravity into the Water Panel evaporator where part of the water is evaporated. The overflow water flushes the majority of the minerals left after evaporation off the Water Panel evaporator, through the 1/2" drain spud at the bottom of the unit through the drain line to the floor drain. **Note:** With the Model 400, water that is not evaporated initially is contained and then wicked up by the water panel to be evaporated at a later time.

To clean orifice, gently insert a fine needle through the small opening. As an alternative, use a drill to clean out the opening: use a #77 drill (0.018" dia.) for Models 110, 220, 400, 550, 550A, 558, 560, 560A, 568 & 600; use a #73 drill (0.024" dia.) for Models 112, 224, 330, 350, 360, 440, 760, 760A, 768 & 700. If the opening cannot be cleaned out or is enlarged, replace with new orifice (white for the 110, 220; red for the 112, 224, 330; blue for the 350, 360, 440, 760, 760A, 768, 700; yellow for the 400,550, 550A, 558, 560, 560A, 568, 600). Models 445, 445A & 448 have no orifice.

# INDIVIDUAL UNIT SERVICE—MODELS 220-224-400-440-550-550A-558-560-560A-568-600

**CAUTION:** 1. Sudden operation may cause personal injury or property damage. Turn the Automatic Humidifier Control or manual humidistat to "Off" or lowest setting before servicing or troubleshooting these units.

## I. LACK OF HUMIDITY

- Check The Home — See Pages 2 and 3.
- Check Furnace Operation — See Page 3.
- Check The Humidity Control — See Page 4.
- General Maintenance — See Pages 4 and 5.

**1. AIR FLOW** — Be sure the damper in the duct between the two plenums is open. Air flow is based on a 0.2 total static pressure difference between the supply and return plenums. The static pressure can be determined with a U-Tube Manometer calibrated in inches of water. Adjust the damper to obtain proper air flow at pressures greater than 0.2 inches of water.

**2. ELECTRICAL COMPONENTS** — The transformer must be isolated from multispeed motors with an RP Model 50 Current Sensing Relay. All components should be tested in place making sure all electrical connections are secure and there are no breaks in the service. If the solenoid valve isn't working with the humidistat circuit closed (see diagram) and the furnace blower is running, disconnect electrical power and insert a transformer that is known to function and check. If the solenoid valve functions, replace the transformer. If the solenoid valve does not function, replace the valve.

**Note:** With the Model 400, both floats must be in the down position for electrical connection.

### Aprilaire Humidifier Control

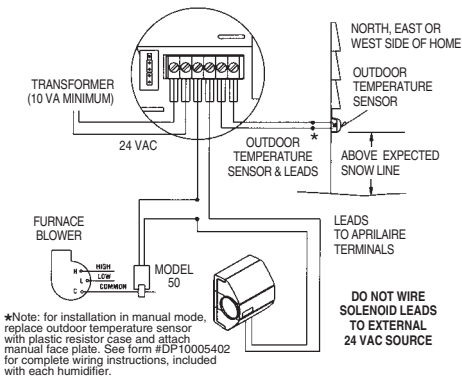

### Manual Humidistat

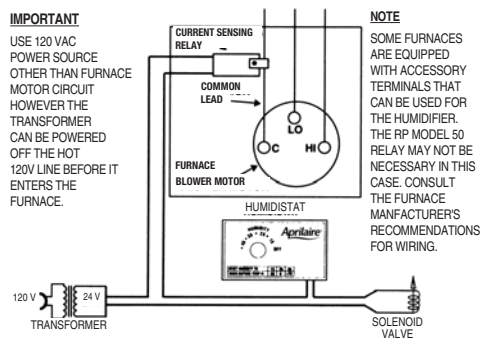

**II. EXCESS HUMIDITY** — See Page 4.

MODELS 220-224-400-440-550-550A-558-560-560A-568-600

### **III. LEAKING WATER** — See Page 4.

The Models 220 and 224 are provided with a cover over the distribution tray. These covers are quite effective in minimizing water bubbling out of the feed tray up to approximately 0.4 in. static pressure. A damper should be included in the bypass between the supply and return plenum to relieve the pressure that can be created by zone dampers completely closed with the furnace blower still operating. We might also suggest that zone dampers be slightly cracked to relieve the pressure and therefore reduce the static pressure in the plenum.

### **IV. NOISE** — See Page 4.

### **V. Model 400 troubleshooting Procedure**

The two floats in the chambers at the base of the scale control insert activate switches in the water level sensor assembly, which control power to the solenoid valve. The float on the right is the primary control mechanism. When the water level in the chamber on the right rises, the float disconnects power to the solenoid valve, shutting off the water. As the water level drops, the float activates the switch, energizing the solenoid valve, which opens and sends water to the distributor tray. The float in the chamber on the left controls an over-flow protection circuit. If the primary float fails to shut off the solenoid valve, water will flow into the chamber on the left, raising that float and disconnecting power to the solenoid valve. If both floats fail to disconnect power to the solenoid valve or if the valve fails in the open position, water will flow into the safety overflow line.

- Check both floats, the chambers, and the float cover. Make sure the float cover is properly snapped into place and that both floats move freely up and down.
- Check that the solenoid valve closes when de-energized.
- Check the electrical continuity of the water level sensor circuit. With both floats down, the circuit should be closed. With either float up, the circuit should be open.

### **VI. GENERAL MAINTENANCE** — See Pages 4 and 5.



# EXPLODED RP APRILAIRE PLENUM HUMIDIFIER (MODELS 220 & 224)

**MODELS 220-224**

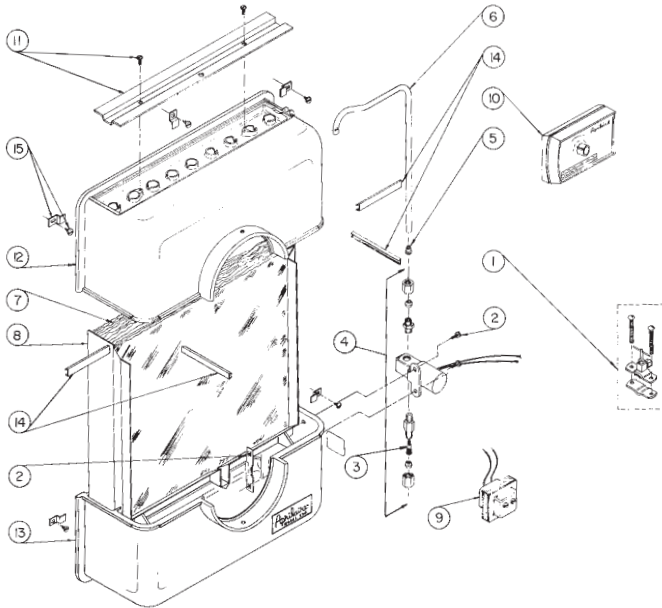

**Instructions for Ordering Parts**  
**Specify:**  
**MODEL NO. — PART NAME — PART NO.**

NO.	PART NAME	QTY/CTN	MODEL 220	MODEL 224
			PART NO.	PART NO.
1	Saddle Valve	1	4001	4001
2	Screw and Clip Set	6	4027	4027
3	In-Line Strainer	12	4004	4004
4	Water Solenoid Valve	1	4040	4040
5	*Orifice	(144/ctn.) 12 - 12 pks.	4007	4021
6	Copper Tube	1	4041	4042
7	Water Panel® Evaporator	10	10	12
8	Scale Control Insert	12	4009	4023
9	Transformer	1	4010	4010
10	Humidistat	1	4016	4016
11	Water Distribution Pan Cover	1	4043	4044
12	Upper Housing	1	4045	4046
13	Lower Housing	1	4048	4049
14	Closure Clip Set	6 sets/ctn.	4050	4050
15	*Z" Clip Retainer Set	6 sets/ctn.	4052	4052
<b>OTHER PARTS</b>				
	Humidifier Control	1	56	56
	Outdoor Temp Sensor	1	4278	4278
	Humidifier Control Gasket	1	4305	4305
	*O" Ring for Bullet Shaped Solenoid Valve	12	4006	4006
	Strainer for Bullet Shaped Solenoid Valve	6	4103	4103
	Drain Spud Replacement Kit	6	4038	4038
	Humidistat Adapter Plate	20	4039	4039
	Shock Arrestor	1	4280	4280

\* Orifice 4007-White -- 4021-Red

# EXPLODED RP APRILAIRE PLENUM HUMIDIFIER (MODEL 440)

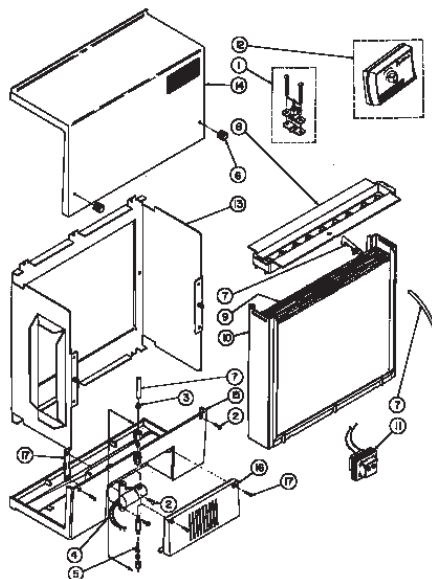

**MODEL 440**

## Instructions for Ordering Parts

Specify:

MODEL NO. — PART NAME — PART NO.

1	Backflow Valve	1	4081
2	Screen and Clip Set	1	4088
3	Orifice (Blue)	(146ctn.) 12 - 12 pks.	4232
4	Water Selector Valve (24 Volt)	1	4043
5	In-Line Strainer	12	4084
6	Wash (Top Cover)	2	4186
7	Fuel Tube and Mounds	1	4078
8	Water Distribution Tray	1	4081
9	Water Pencil Evaporator	10	12
10	Beats Control Insert	12	4089
11	Transformer	1	4019
12	Humidistat	1	4015
13	Metal Frame	1	4171
14	Top Cover (Wash and evaporator)	1	4182
15	Lower Housing	1	4183
16	Selector Cover	1	4187
	Humidifier Control	1	28
	Outdoor Temp Sensor	1	4278
	Humidifier Control Circuit	1	4325
	"C" Ring for Relief-Wrapped Selector Valve	12	4038
	O-Ring for Relief-Wrapped Selector Valve	8	4183
	Drain Spud Replacement Kit	8	4088
	Humidistat Adapter Plate	20	4039
	Elect. Averager	1	4288

**EXPLODED RP APRILAIRE PLENUM HUMIDIFIER  
(MODELS 550, 550A, 558 / 560, 560A, 568)**

**MODELS 550-550A-558-560-560A-568**

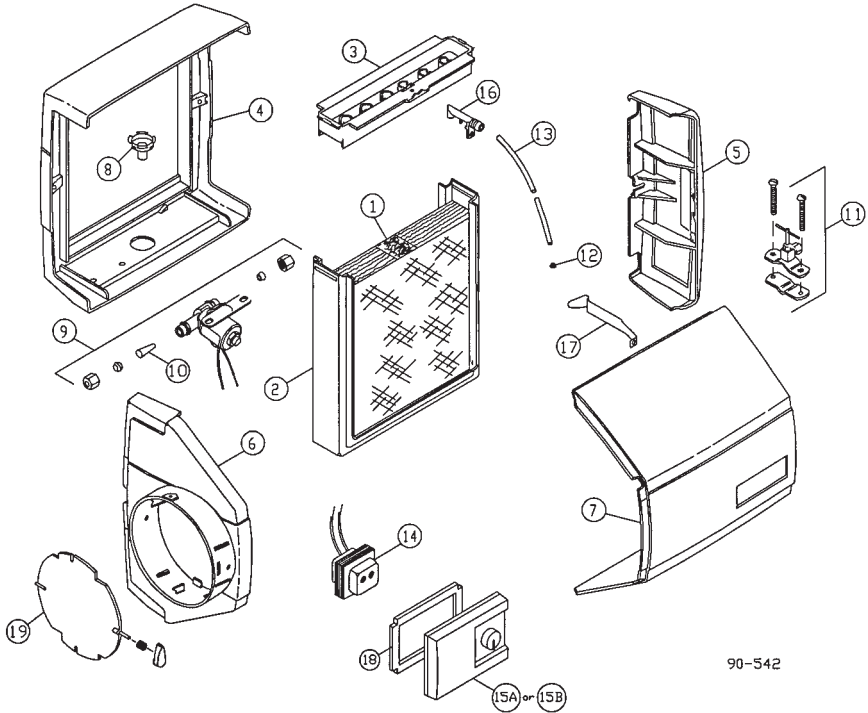

90-542

*Instructions for Ordering Parts*  
*Specify:*  
**MODEL NO. — PART NAME — PART NO.**

NO.	PART NAME	QTY/CTN	MODELS 558/550A/550	MODELS 568/560A/560
			PART NO.	PART NO.
1	Water Panel® Evaporator	10	10	35
2	Scale Control Insert	(4217-10) (4236-12)	4217	4236
3	Water Distribution Tray	1	4218	4277
4	Base	1	4219	4262
5	End Panel	1	4220	4263
6	Duct Panel for damper	1	4526	N/A
7	Cover With Latch And Label	1	4222	4265
8	Drain Spud	6	4223	4223
9	Water Solenoid Valve (24 Volt)	1	4040	4040
10	In-Line Strainer	12	4004	4004
11	Saddle Valve	1	4001	4001
12	Orifice	(144/ctn.) 12 - 12 pks.	4231	4232
13	Feed Tube With Compression Sleeve	1	4226	4266
14	Transformer	1	4010	4010
15A	Humidifier Control	1	56	56
15B	Manual Humidistat	1	4016	4016
16	Nozzle	1	4184	4184
17	Cover Latch Spring	1	4225	4225
18	Humidifier Control Gasket	1	4305	4305
19	Damper Assembly	1	4332	N/A
20	Duct Panel w/o Damper (not shown)	1	4221	4264
<b>OTHER PARTS</b>				
	Outdoor Temp Sensor	1	4278	4278
	Humidistat Adapter Plate	20	4039	4039
	Current Sensing Relay	1	50	50
	Saddle Valve Adapter	6	4229	4229
	Shock Arrestor	1	4280	4280

## EXPLODED RP APRILAIRE PLENUM HUMIDIFIER (MODEL 400)

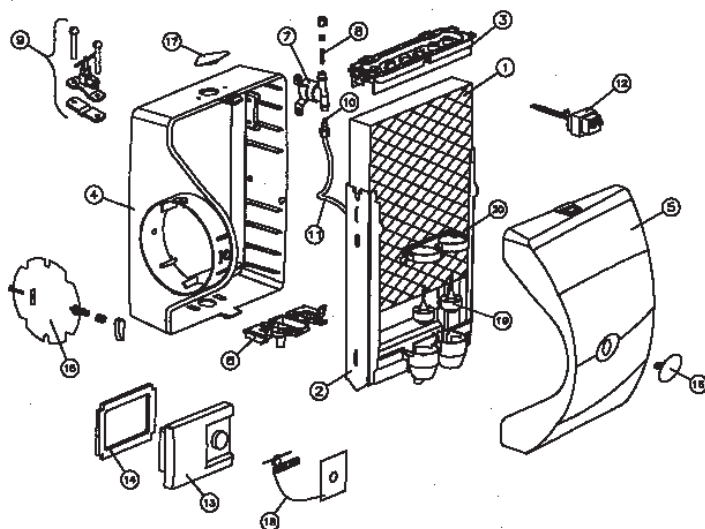

### Instructions for Ordering Parts

Specify:

MODEL NO. — PART NAME — PART NO.

NO.	PART NAME	QTY/CTN	PART NO.
1	Water Panel Evaporator	10	45
2	Scale Control Insert/Floater Chamber	6	4403
3	Water Distribution Tray	1	4407
4	Base	1	4404
5	Cover	1	4329
6	Water Level Sensor Assembly	1	4410
7	Water Solenoid Valve (24 Volt)	1	4040
8	In Line Strainer	12	4004
9	Saddle Valve	1	4001
10	Orifice (Yellow)	(144/ctn.)12 - 12 pks.	4281
11	Feed Tube With Compression Sleeve	1	4335
12	Transformer	1	4010
13	Humidifier Control	1	58
14	Humidifier Control Gasket	1	4305
15	Damper Assembly	1	4332
16	Name Plate	1	4409
17	Hole Plug	1	4408
18	Resistor Case & Manual Label	1	4336
19	Float Assembly	1	4406
20	Float Cover	1	4405
<b>OPTION PARTS</b>			
	Outdoor Temp Sensor	1	4278
	Current Sensing Relay	1	50
	Saddle Valve Adapter	8	4229
	Shock Arrestor	1	4280

**MODEL 400**

## EXPLODED RP APRILAIRE PLENUM HUMIDIFIER (MODEL 600)

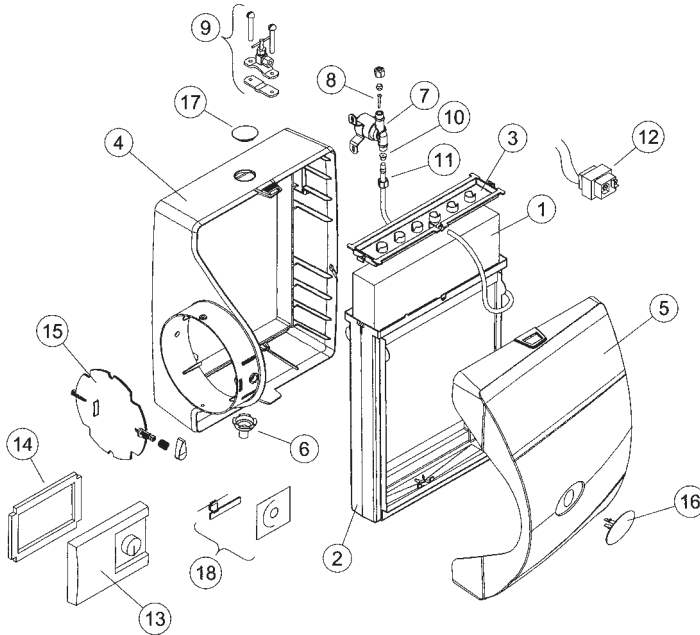

### *Instructions for Ordering Parts Specify:*

**MODEL NO. — PART NAME — PART NO.**

NO.	PART NAME	QTY/CTN	PART NO.
1	Water Panel Evaporator	10	35
2	Scale Control Insert	8	4330
3	Water Distribution Tray	1	4331
4	Base	1	4328
5	Cover	1	4329
6	Drain Spud	6	4223
7	Water Solenoid Valve (24Volt)	1	4040
8	In-Line Strainer	12	4004
9	Saddle Valve	1	4001
10	Orifice (Yellow)	(144/ctn.) 12-12 pks	4231
11	Feed Tube w/Compression Sleeve	1	4335
12	Transformer	1	4010
13	Humidifier Control	1	56
14	Automatic Humidifier Control Gasket	1	4305
15	Damper Assembly	1	4332
16	Name Plate	1	4333
17	Hole Plug	1	4334
18	Resistor Case & Manual Label	1	4336
<b>OTHER PARTS</b>			
	Outdoor Temp Sensor	1	4278
	Current Sensing Relay	1	50
	Saddle Valve Adapter	6	4229
	Shock Arrestor	1	4280

# INDIVIDUAL UNIT SERVICE—MODELS 760, 760A, 768 & 700

- WARNING:**
- 120 VOLTS may cause serious injury from electrical shock. Disconnect power and shut off water supply before servicing or troubleshooting this unit.
  - Rotating or electrical components may cause serious injury from contact. Keep hands and face clear when checking operation.

## I. LACK OF HUMIDITY

- **Check The Home** — See Pages 2 and 3.
- **Check Furnace Operation** — See Page 3.
- **Check The Humidity Control** — See Page 4.
- **General Maintenance** — See Pages 4 and 5.

**1. AIR FLOW/ELECTRICAL COMPONENTS** — To check the fan, disconnect power and remove cover assembly from the base assembly. The fan blade should be tight on the shaft and 1/3 through the orifice plate toward the motorboard. If not, reposition the fan and tighten set screw to flat on the motor shaft.

### Aprilaire Humidifier Control

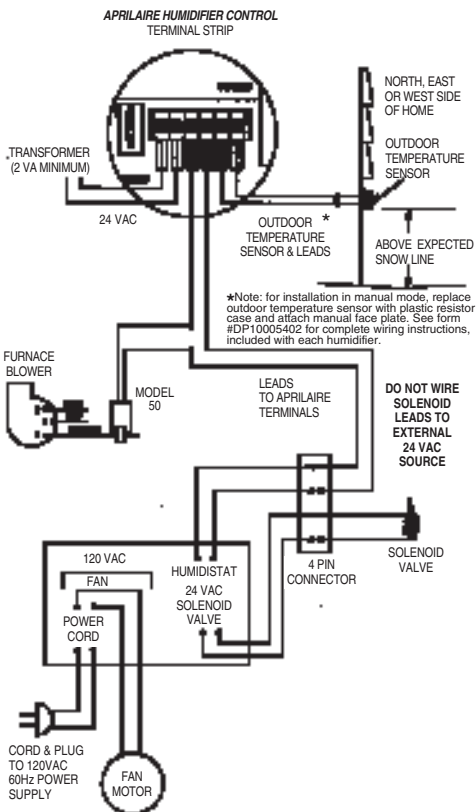

### Manual Humidistat

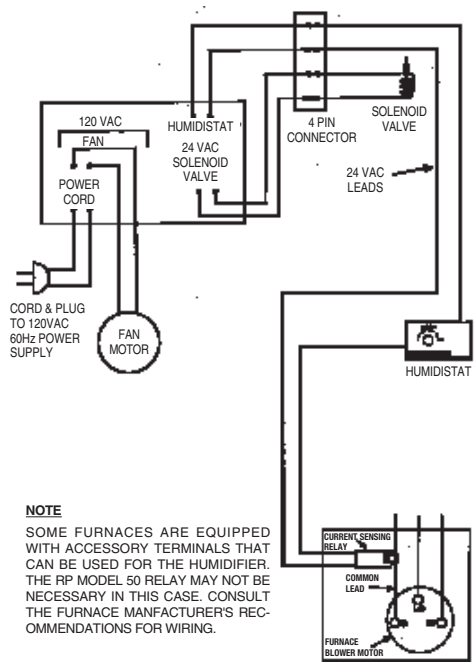

### IMPORTANT

USE 120 VAC POWER SOURCE OTHER THAN FURNACE MOTOR CIRCUIT.

The motor will operate if power is connected to the unit, the furnace blower is running and the humidistat switch is closed. To check the fan motor:

### **APRILAIRE HUMIDIFIER CONTROL- AUTOMATIC AND MANUAL MODE**

1. Replace the cover assembly and reconnect power.
2. Activate furnace blower and call for heat by turning your thermostat up to a higher temperature.
3. Turn knob to “Test” position.
4. With furnace blower operating and furnace calling for heat, the **fan motor** as well as the solenoid valve of the humidifier will operate for one minute.
5. After one minute, the humidifier and Humidifier Control will shut off.
6. Turn knob back to original setting.

### **MANUAL HUMIDISTAT**

1. Replace the cover assembly and reconnect power.
2. Activate furnace blower by setting your thermostat fan switch to the “ON” position.
3. Turn humidistat dial to its highest setting.
4. With furnace blower operating and furnace calling for heat, the humidifier **fan motor** as well as the solenoid valve of the humidifier will operate.
5. After approximately one minute, turn dial back to original setting.
6. Turn thermostat fan switch back to original setting.

If the humidifier does not operate, disconnect power and check all wiring connections and humidistat contacts. If a Model 50 relay is being used, check the installation instructions concerning the number of wire wraps. Reconnect power and check operation. If the unit does not operate, disconnect power.

Remove the cover assembly from the base assembly. Mark the fan blade position and remove it from the motor shaft. Using a small screw driver, depress the plastic side tabs on the 4 pin electrical connector and remove it from the orifice plate. Remove the 4 screws that connect the orifice plate and bridge to the cover. Place the bridge section so that the circuit board and motor are facing up.

Remove the wires from the circuit board terminals labeled “humidistat”. Place a jumper wire across these terminals. Reconnect the power. **The fan motor leads are 120 VAC! Use extreme caution!** Check the voltage across the fan terminals and solenoid terminals. If either component is not working, replace that particular component. If voltage is not present at either terminal, replace the circuit board.

**II. EXCESS HUMIDITY** — See Page 4.

**III. LEAKING WATER** — See Page 4.

**IV. NOISE** — See Page 4.

**V. GENERAL MAINTENANCE** — See Pages 4 and 5.

# EXPLODED RP APRILAIRE PLENUM HUMIDIFIER (MODELS 760 760A 768 & 700)

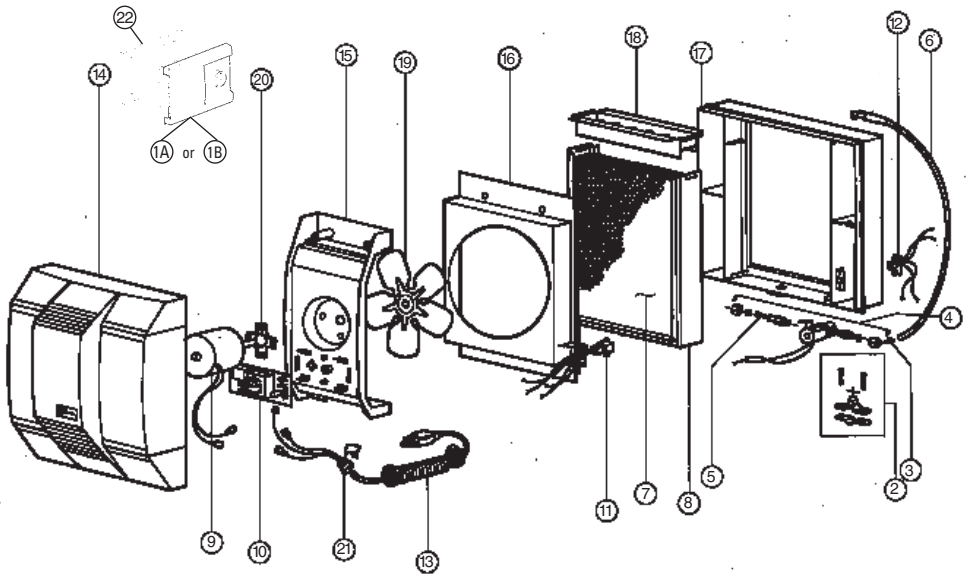

*Instructions for Ordering Parts*  
Specify:  
MODEL NO. — PART NAME — PART NO.

14	Humidifier Control	1	401
15	Motor / Fan/Blade	1	401B
2	Inside Valve	1	401C
3	Filter Mesh	(Models 768 - 700 only)	402
4	Water Reservoir Valve (21 Volt)	1	403
5	In-Line Filter	1E	404
6	Plastic Valve and Mount	1	405
7	Water Filter/Separator	1D	406
8	Scale Control Lever	1B	407
9	Motor	1	407
10	Control Board	1	408
11	Fan/Blade Assembly	1	409
12	W/W Mounting Assembly	1	410
13	Power Cord	1	411
14	Cover	1	412
15	Motor/Mount Bridge	1	413
16	Motor/Mount Collar Plate	1	414
17	Base	1	415
18	Water Distribution Tray	1	416
19	Fan Blade	1	417
20	Rubber Insulator	1	418
21	Resistive Element	1	419
22	Humidifier Control/Control	1	420
<b>Optional Accessories</b>			
	Outdoor Wiring Device	1	421
	Humidifier Adapter Plate	20	422
	Control/Service Filter	1	423
	Scale Valve Cleaner	8	424
	Showering Brush	8	425
	Shock Absorber	1	426

**MODELS 760-760A-768-700**



# INDIVIDUAL UNIT SERVICE—MODELS 445, 445A & 448

- WARNING:**
1. 120 VOLTS may cause serious injury from electrical shock. Disconnect power and shut off water supply before servicing or troubleshooting this unit.
  2. Rotating or electrical components may cause serious injury from contact. Keep hands and face clear when checking operation.

## I. LACK OF HUMIDITY

- Check The Home — See Pages 2 and 3.
- Check Furnace Operation — See Page 3.
- Check The Humidity Control — See Page 4.
- General Maintenance — See Pages 4 and 5.

## 1. WATER SUPPLY PROBLEMS

a. Disconnect electrical power. Remove the motor board cover. Lubricate self-aligning motor bearings at the yellow hole on top and inside the yellow mark on the side of the motor. After lubrication, **carefully** remove reservoir and pump cap. Remove any deposits present in the pump column, impeller area or pump cap. Clean out pump cap outlet. Hold shaft at impeller and rotate slowly while working shaft up and down. Check operation.

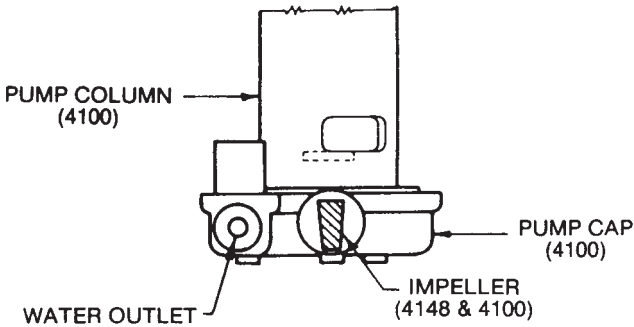

Fig. 1

- b. Water level in reservoir should be 1/2" from top of black reservoir liner. If necessary, bend float arm up slightly to adjust water level.
  - c. Position the impeller properly in the center of the pump cap. The impeller must have the black marking up towards the motor. (Fig. 1)
  - d. Open water outlet in the pump cap with 5/32" drill bit. (Fig. 1)
  - e. Remove feed tube. Flex to remove deposits and flush with water under pressure. Reattach feed tube and remove any sharp bends.
  - f. Check operation. If motor does not operate, check for pump motor cooling fan obstructions. Pump motor cooling fan must not be pushed too far down on shaft or it will obstruct shaft rotation. If motor still does not operate, replace motor.
- 2. AIR FLOW** — Be sure the damper in the duct between the two plenums is open! Air Flow is based on a 0.2 total static pressure difference between the supply and return plenums. The static pressure can be determined with a U-Tube Manometer calibrated in inches of water. Adjust the damper to obtain proper air flow at pressures greater than 0.2 inches of water.

**3. ELECTRICAL COMPONENTS** — All components should be tested in place making sure all electrical connections are secure and there are no breaks in the service. If the pump motor isn't working with the humidistat circuit closed (see diagram) and the furnace blower running, disconnect electrical power and connect the blue motor lead directly to the black power cord lead and check. If the pump runs, replace the relay/transformer or 120 volt humidifier control (after Serial No. 337,941). If the pump doesn't run, or water flow does not reach outlet feed nozzle, replace the pump motor.

**II. EXCESS HUMIDITY** — See Page 4.

**III. LEAKING WATER**

● **Reservoir and Pump Section**

The Model 445, 445A and 448 are circulating units which **will require maintenance every 30 days**. Complete servicing instructions for both the water reservoir and circulating pump are located in the homeowners manual.

**Aprilaire Humidifier Control**

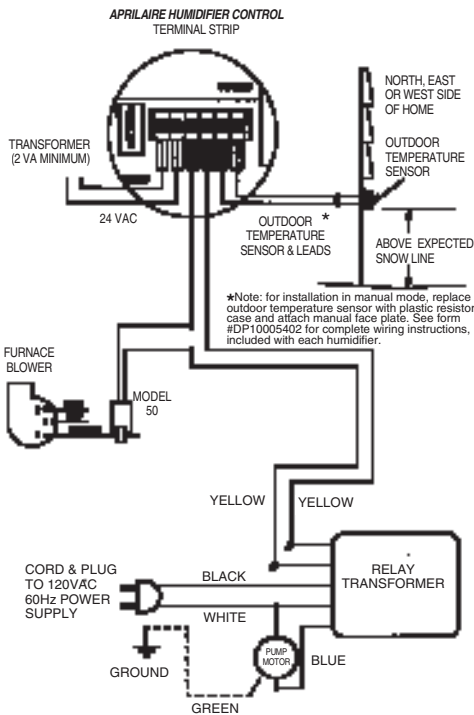

**Manual Humidistat**

**IMPORTANT**  
USE 120 VAC POWER SOURCE OTHER THAN FURNACE MOTOR CIRCUIT HOWEVER THE TRANSFORMER CAN BE POWERED OFF THE HOT 120V LINE BEFORE IT ENTERS THE FURNACE.

**NOTE**

SOME FURNACES ARE EQUIPPED WITH ACCESSORY TERMINALS THAT CAN BE USED FOR THE HUMIDIFIER. THE RP MODEL 50 RELAY MAY NOT BE NECESSARY IN THIS CASE. CONSULT THE FURNACE MANUFACTURER'S RECOMMENDATIONS FOR WIRING.

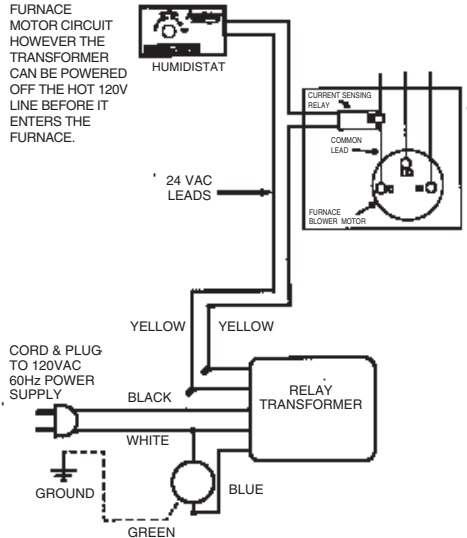

**IV. NOISE**

● **Pump Motor**

- Disconnect electrical power. Remove the motor board cover.
- Check fan blade.
- Oil with two drops SAE #20 oil in the yellow hole on top and inside the yellow mark on the side of the motor.

**V. GENERAL MAINTENANCE** — See Pages 4 and 5.

# EXPLODED RP APRILAIRE PLENUM HUMIDIFIER (MODELS 445, 445A & 448)

**MODELS 445-445A-448**

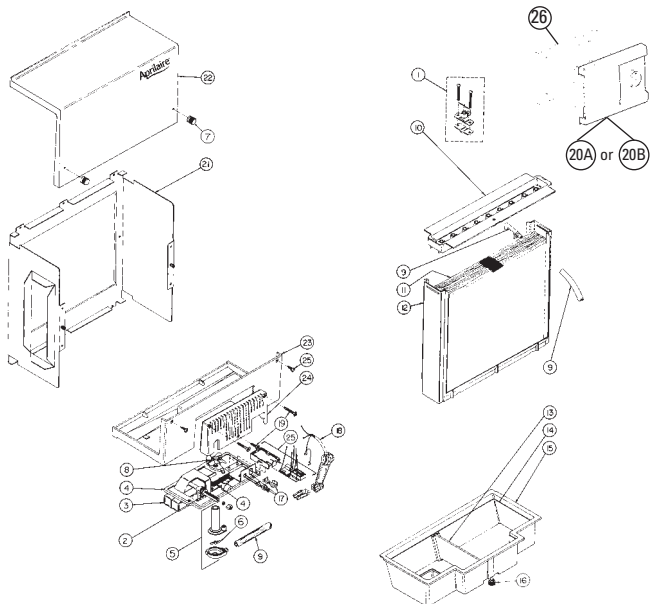

## Instructions for Ordering Parts

*Specify:*

**MODEL NO. — PART NAME — PART NO.**

NO.	PART NAME	QTY/CTN	PART NO.
1	Saddle Valve	1	4001
2	Float, Float Valve Body and Arm	1	4087
3	Float (only)	1	4088
4	Pump Assembly/Motor Board	1	4089
5	Pump Parts Kit	1	4100
6	Impellor (included in Pump Assembly)	6	4148
7	Knobs (Top Cover)	2	4166
8	Fan Blade	1	4090
9	Hose and Nozzle	1	4091
10	Water Distribution Tray	1	4081
11	Water Panel® Evaporator	10	12
12	Scale Control Insert	12	4080
13	Reservoir Divider	1	4092
14	Reservoir Liner	6	4093
15	Reservoir	1	4165
16	Reservoir Bolt Kit	1	4101
17	Electrical Bracket and Grommet	1	4095
18	Power Cord	1	4261
19	Screw and Clip Set	1	4086
20A	Humidifier Control	1	56
20B	Manual Humidistat	1	4016
21	Metal Frame	1	4171
22	Top Cover (Knobs are separate)	1	4162
23	Lower Housing	1	4164
24	Motor Cover	1	4179
25	120 Volt Humidifier Control - Replaces 4013	1	4258
26	Control Gasket	1	4305
<b>OTHER PARTS</b>			
	Outdoor Temp Sensor	1	4278
	Humidistat Adapter Plate	20	4039
	Motor Board Only	1	4159
	Float Valve Rubber Stopper	10	4269

# INDIVIDUAL UNIT SERVICE—MODELS 350 & 360

- WARNING:**
1. 120 VOLTS may cause serious injury from electrical shock. Disconnect power and shut off water supply before servicing or troubleshooting these units.
  2. Rotating or electrical components may cause serious injury from contact. Keep hands and face clear when checking operation.

## I. LACK OF HUMIDITY

- Check The Home — See Pages 2 and 3.
- Check Furnace Operation — See Page 3.
- Check The Humidity Control — See Page 4.
- General Maintenance — See Pages 4 and 5.

1. **AIR FLOW** — Disconnect electrical power and remove the inlet grille and Wet Pak®. With hands and face clear, reconnect electrical power. If the fan blade is not rotating and the motor shaft is, disconnect electrical power and secure the blade on the shaft. When the blade is in the proper position, 1/3 of the blade extends thru the orifice towards the outlet adapter or grille and 2/3 is thru the orifice towards the motor.

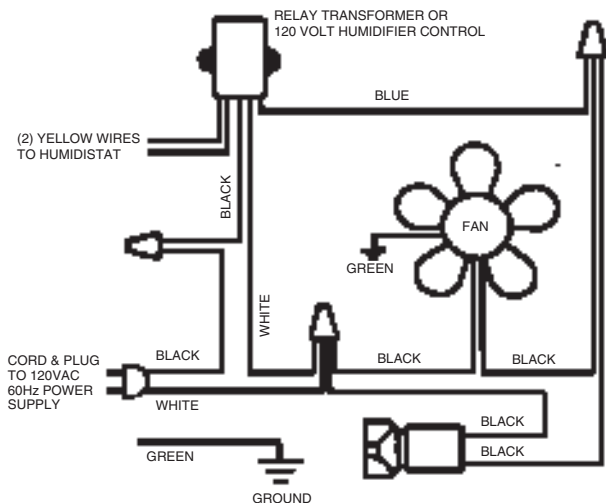

2. **ELECTRICAL COMPONENTS** — All components should be tested in place before removal, making sure all electrical connections are secure and there are no breaks in the service. The 120 volt humidifier control replaces the relay/transformer after Serial No. 17500 (Model 350) and after Serial No. 16715 (Model 360).

II. **EXCESS HUMIDITY** — See Page 4.

III. **LEAKING WATER** — See Page 4.

IV. **NOISE** — See Page 4.

V. **GENERAL MAINTENANCE** — See Pages 4 and 5.

# EXPLODED RP APRILAIRE PLENUM HUMIDIFIER (MODEL 350)

**MODEL 350**

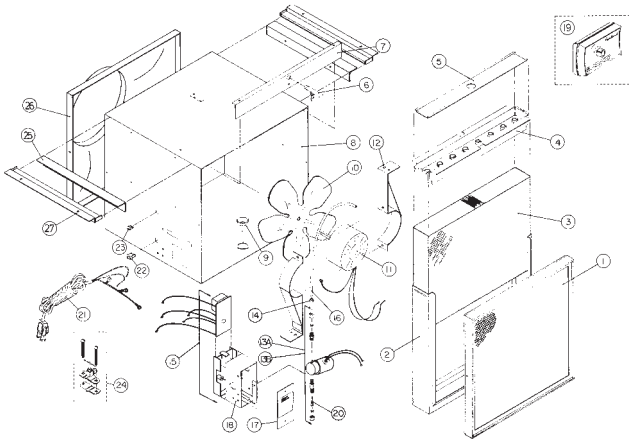

## Instructions for Ordering Parts

**Specify:**

**MODEL NO. — PART NAME — PART NO.**

NO.	PART NAME	QTY/CTN	PART NO.
1	Inlet Frame	1	4206
2	Scale Control Insert	12	4181
3	Water Panel® Evaporator	10	35
4	Distribution Tray Coated	1	4182
5	Distribution Tray Cover	1	4183
6	Nozzle	1	4184
7	Baffle	1	4185
8	Housing	1	4186
9	Drain Spud	1	4187
10	Fan Blade	1	4188
11	Motor	1	4189
12	Motor Brackets	1 Set	4190
13A	Solenoid Valve (Metal Junction Box)	1	4255
13B	Solenoid Valve (Plastic Junction Box)	1	4191
14	Orifice (Blue)	(144/ctn.) 12 - 12 pks.	4232
15	120 Volt Humidifier Control - Replaces 4013	1	4258
16	Tubing & Plastic Barrel	1	4079
17	Junction Box Cover	1	4193
18	Junction Box	1	4194
19	Humidistat	1	4016
20	In-Line Strainer	12	4004
21	Power Cord	1	4260
22	Strain Relief Bushing - Large	1	4196
23	Strain Relief Bushing - Small	1	4197
24	Saddle Valve	1	4001
25	Angle Support	2	4200
26	Outlet Adapter	1	4201
27	Joist Bracket	2	4202
<b>OTHER PARTS</b>			
	Screws and Clips (not shown)	1	4203
	Saddle Valve Adapter (not shown)	6	4229
	Shock Arrestor	1	4280

# EXPLODED RP APRILAIRE PLENUM HUMIDIFIER (MODEL 360)

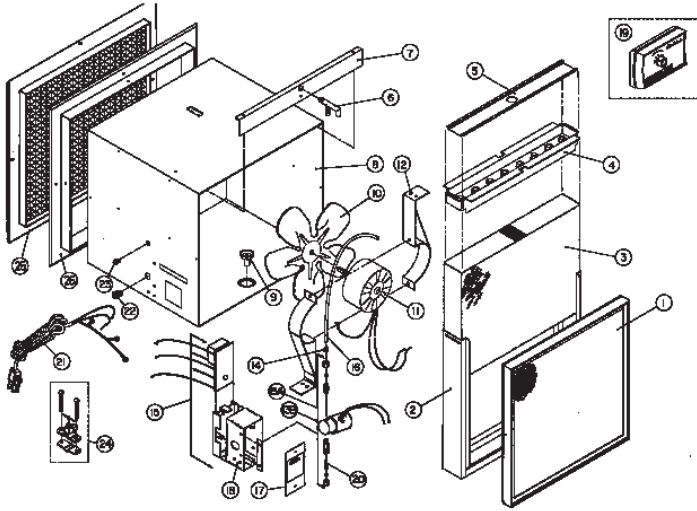

**MODEL 360**

*Instructions for Ordering Parts*  
Specify:  
**MODEL NO. — PART NAME — PART NO.**

1	Inlet Plenum	1	4000
2	Rear Control Mount	12	4001
3	Water Pressure Expander	10	4002
4	Distribution Tray Control	1	4003
5	Distribution Tray Cover	1	4004
6	Rear	1	4005
7	Rear	1	4006
8	Housing	1	4007
9	Dial Ring	1	4008
10	Fan Blade	1	4009
11	Motor	1	4010
12	Motor Housing	1	4011
13	Schedul Valve of Inlet Aprilaire Part	1	4012
14	Schedul Valve of Inlet Aprilaire Part	1	4013
15	Control Motor	(740000) 1/2 - 1/8 pka.	4014
16	1/2\"/>		
17	Terminal Block Cover	1	4015
18	Terminal Block	1	4016
19	1/2\"/>		
20	Power Cord	1	4017
21	Black Plastic Fastener - Large	1	4018
22	Black Plastic Fastener - Small	1	4019
23	Backplate Valve	1	4020
24	Plate	1	4021
25	Inlet Filter Frame	1	4022
	Screen and Glass Back-Block	1	4023
	Backplate Valve-Motor Attachment	1	4024
	Mount-Accessory	1	4025

# INDIVIDUAL UNIT SERVICE—MODELS 110 & 112

- WARNING:**
1. 120 VOLTS may cause serious injury from electrical shock. Disconnect power and shut off water supply before servicing or troubleshooting these units.
  2. Rotating or electrical components may cause serious injury from contact. Keep hands and face clear when checking operation.

## I. LACK OF HUMIDITY

- Check The Home — See Pages 2 and 3.
- Check Furnace Operation — See Page 3.
- Check The Humidity Control — See Page 4.
- General Maintenance — See Pages 4 and 5.

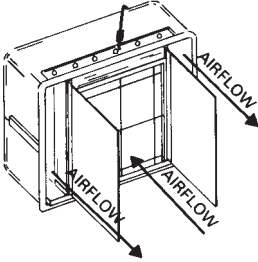

**1. AIR FLOW** — Disconnect electrical power and turn off water supply. Remove unit from plenum and remove upper housing. With hands and face clear, reconnect electrical power. If the fan blade is not rotating and the motor shaft is, disconnect electrical power and secure the blade on the shaft. When the blade is in the proper position, 1/3 of the blade extends thru the opening in the shroud towards the motor and 2/3 is thru the shroud towards the Water Panel.

In some unusual situations, there may be a particular air movement thru the plenum that makes it difficult for the fan to draw new air into the Water Panel evaporator. In a situation like this, install 6" dividers between the intake and discharge of the air flow as shown in the above diagram. This will eliminate the possibility of recirculating air that is already humidified.

**2. ELECTRICAL COMPONENTS** — There are two electrical circuits in the Models 110- 112: a 24 volt control circuit and a 120 volt power circuit. Failure of any electrical components in the humidifier may result in a lack of humidity or if stuck in the operating position could result in excess humidity. All components should be tested in place before removal making sure all electrical connections are secure and there are no breaks in the service.

### Old Style – Up to Serial # 484,805 (Model 110); 410,760 (Model 112)

- a. Disconnect electrical power and check humidistat switch contacts and all wiring connections.
- b. If both the motor and solenoid are not operating, the trouble may be in the relay. Disconnect electrical power and insert a relay that is known to function and check.
- c. If motor and solenoid still won't function, disconnect power to the furnace and replace the transformer.
- d. If either the motor or solenoid valve is not operating and the other is operating, the relay transformer and humidistat can be eliminated as a source of trouble. Disconnect electrical power and replace the motor or solenoid valve whichever is not working.

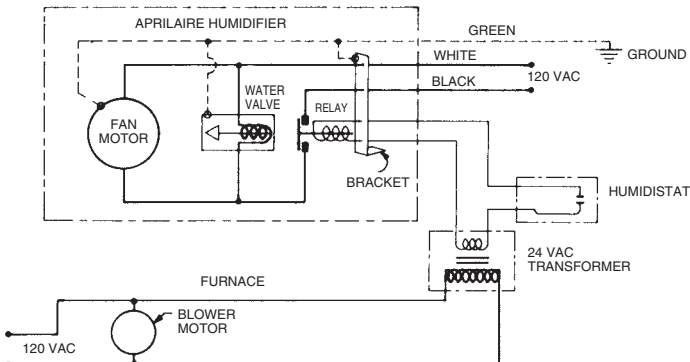

**New Style After Serial #484,805 (Model 110);  
410,760 (Model 112) and with Date Code**

- a. Disconnect electrical power and check humidistat switch contacts and all wiring connections.
- b. If both the motor and solenoid are not operating, the trouble may be in the relay transformer or the 120 volt humidifier control (after Serial #800,535–Model 110 or 534,903–Model 112). Disconnect electrical power and insert a 120 volt humidifier control or relay transformer that is known to function and check operation.
- c. If either the motor or solenoid valve is not operating and the other is operating, the relay transformer and humidistat can be eliminated as a source of trouble. Disconnect electrical power and replace the motor or solenoid valve whichever is not working.

**NOTE**

SOME FURNACES ARE EQUIPPED WITH ACCESSORY TERMINALS THAT CAN BE USED FOR THE HUMIDIFIER. THE RP MODEL 50 RELAY MAY NOT BE NECESSARY IN THIS CASE. CONSULT THE FURNACE MANUFACTURER'S RECOMMENDATIONS FOR WIRING.

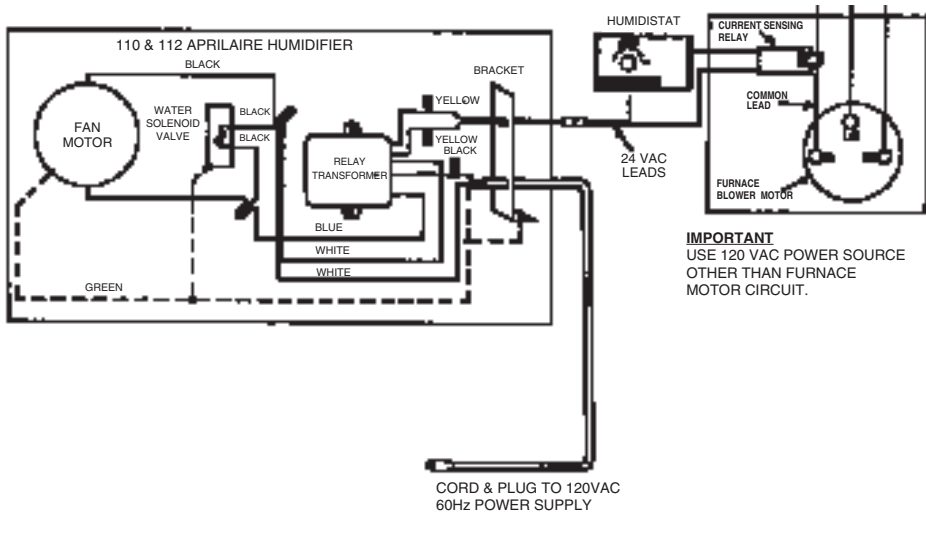

**IMPORTANT**

USE 120 VAC POWER SOURCE  
OTHER THAN FURNACE  
MOTOR CIRCUIT.

**II. EXCESS HUMIDITY** — See Page 4.

**III. LEAKING WATER** — See Page 4.

The Models 110 and 112 are provided with a cover over the distribution tray. These covers are quite effective in minimizing water bubbling out of the feed tray up to approximately 0.4 in. static pressure. The cover should be sealed with duct tape above this static pressure.

**IV. NOISE** — See Page 4.

**V. GENERAL MAINTENANCE** — See Pages 4 and 5.



# EXPLODED RP APRILAIRE PLENUM HUMIDIFIER (MODELS 110 & 112)

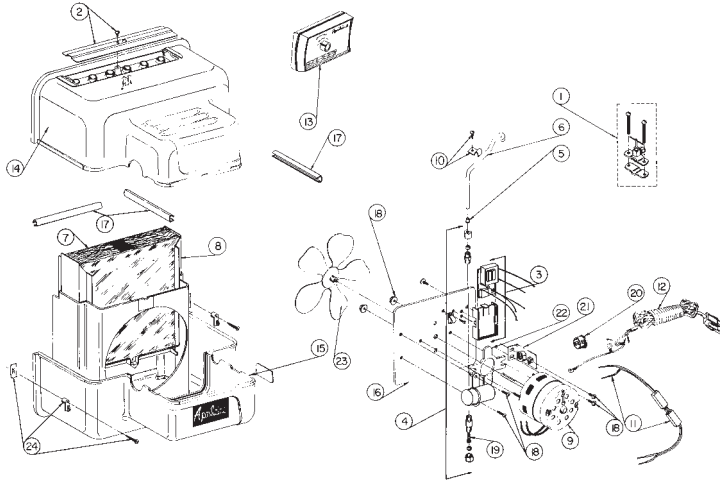

*Instructions for Ordering Parts*  
*Specify:*  
**MODEL NO. — PART NAME — PART NO.**

NO.	PART NAME	QTY/CTN	MODEL 110	MODEL 112
			PART NO.	PART NO.
1	Saddle Valve	1	4001	4001
2	Water Distribution Pan Cover	1	4035	4036
3	120 Volt Humidifier Control - Replaces 4013	1	4258	4258
4	Water Solenoid Valve	1	4005	4005
5	*Orifice	(144/ctn.) 12 - 12 pks.	4007	4021
6	Copper Tube	1	4008	4022
7	Water Panel® Evaporator	10	10	12
8	Scale Control Insert	12	4009	4023
9	Motor	1	4011	4011
10	Feed Tube Clamp	12	4037	4037
11	24V Quick Disconnect	1	4014	4014
12	Power Cord	1	4260	4260
13	Humidstat	1	4016	4016
14	Upper Housing	1	4017	4018
15	Lower Housing	1	4019	4020
16	Motor Mounting Plate	1	4024	4024
17	Closure Clip Set	6 sets/ctn.	4025	4025
18	Screw and Clip Set	6	4027	4027
19	In-Line Strainer	12	4004	4004
20	Nylon Bushing	1	4029	4029
21	Electrical Bracket and Grommet	1	4030	4030
22	Rubber Isolator	6	4031	4031
23	Fan Blade	1	4032	4033
24	Swing Lock Set	6 sets/ctn.	4034	4034
<b>OTHER PARTS</b>				
	Humidifier Control	1	56	56
	Outdoor Temp Sensor	1	4278	4278
	Humidifier Control Gasket	1	4305	4305
	*O* Ring for Bullet Shaped Solenoid Valve	12	4006	4006
	Strainer for Bullet Shaped Solenoid Valve	6	4103	4103
	Drain Spud Replacement Kit	6	4038	4038
	Humidstat Adapter Plate	20	4039	4039
	Transformer (remote)	1	4010	4010
	Relay	1	4012	4012
	Shock Arrestor	1	4280	4280

\* Orifice 4007-White - 4021-Red

## Here are five more products to help you in your quest for... Indoor Air Quality

### Aprilaire®

#### HUMIDIFIER CONTROL

For the ultimate in humidity control, the Aprilaire Humidifier Control is available. Installed out of sight, its exclusive microprocessor technology automatically adjusts to changing outdoor temperatures. This is your assurance of always receiving the optimum humidity level according to outside conditions without the need for manually adjusting your humidifier.



### Aprilaire®

#### HIGH EFFICIENCY AIR CLEANER

In addition to humidification, air cleaning is an important part of the total comfort indoor air quality concept. The Aprilaire High Efficiency Air Cleaner removes up to 99% of the pollen and up to 90% of the dust and dirt from the air circulating through your forced air system. This high efficiency air cleaner is non-electronic, produces no ozone, and saves money on initial and operating costs. Contact your installing contractor for details on this fine product.

### Aprilaire®

#### ELECTRONIC THERMOSTAT

Aprilaire Electronic Thermostats combine convenience, comfort and energy savings in an attractive, award-winning design. Electronic thermostat adjusts indoor temperatures automatically to fit your lifestyle. It's easy to program and is so technically advanced it constantly monitors itself to ensure uninterrupted comfort and operation.



### Aprilaire®

#### ENERGY RECOVERY VENTILATOR

For year-round fresh air in your home, ask your dealer for details on the Aprilaire Energy Recovery Ventilator. You can overcome the problems associated with stale, polluted indoor air. The Energy Recovery Ventilator unit incorporates state-of-the-art technology to provide fresh air to your entire home with minimal loss of energy.

### Aprilaire®

#### ZONE COMFORT CONTROL SYSTEM

Aprilaire Zone Control System keeps every area in your home more comfortable by providing conditioned air only to the area of the home that requires it. By directing the conditioned air only where it's needed, the zone control system can reduce your energy bills by up to 20%. Ask your dealer for details on the zone control system; there's no easier way to ensure comfortable temperatures throughout your home.





**RESEARCH PRODUCTS CORPORATION**

P.O. BOX 1467 • MADISON, WI 53701-1467  
*Call toll-free 1-800-334-6011 • FAX 608/257-4357*

FORM NO. 1780 3.04.04  
DP10006354

Printed in U.S.A.