



INSTALLATION INSTRUCTIONS

Accessory
**WOOD TRIM
STEERING WHEEL
P/N 08U97-S0X-110A**

Application
ODYSSEY

Publications No.
All 26041
Issue Date
AUG 2003

PARTS LIST

Wood trim steering wheel

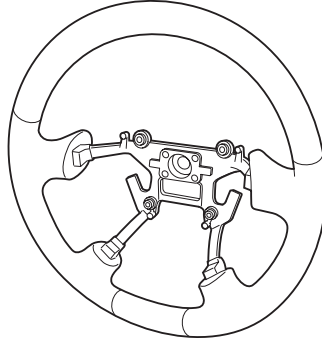

2 Torx bolts, 6 x 12 mm



4 Torx bolts, 6 x 9 mm



TOOLS REQUIRED

Phillips screwdriver
10 mm Combination wrench
Flat-tip screwdriver
19 mm Socket
Torque wrench
Combination wrench
Steering wheel puller
Service Manual
T30 Torx bit
T40 Torx bit

INSTALLATION

Customer Information: The information in this installation instruction is intended for use only by skilled technicians who have the proper tools, equipment, and training to correctly and safely add equipment to your vehicle. These procedures should not be attempted by "do-it-yourselfers."

1. Make sure you have the anti-theft code for the radio, then write down the frequencies for the preset buttons.

2. Disconnect the negative cable from the battery, and wait for at least 3 minutes before you start to install the wood trim steering wheel.
3. Pry up on the retaining tabs, and remove the access panel from the underside of the driver's side airbag.

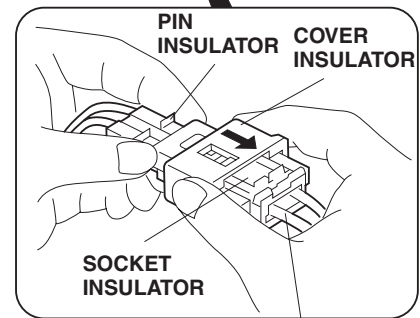
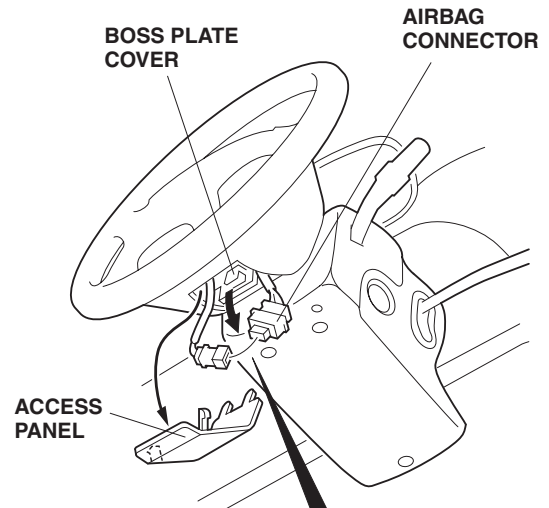

Do not hold on the harness wires.

4. Remove the airbag connector from the boss plate cover.
5. Unplug the airbag connector; while holding the pin insulator, pull out on the cover insulator. Do not pull on the socket insulator.

- Remove and discard the two bolts securing the airbag, and remove the airbag. Carefully set the airbag in a secure location with the pad facing up. Do not drop or bump the airbag against anything.

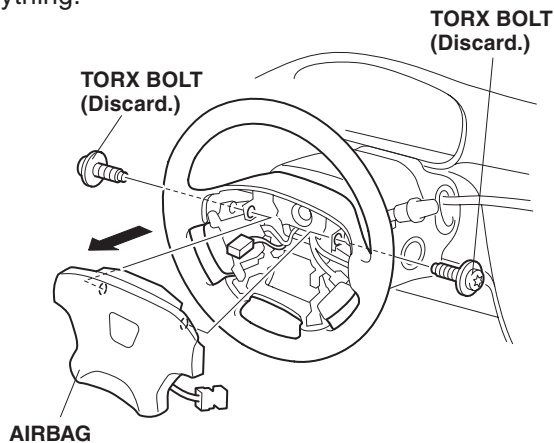

- Turn the steering wheel so the front wheels are in the straight-ahead position.
- Disconnect the gray audio control switch connector (if equipped), the green cruise control switch connector, the black ground terminal, and the white horn connector.

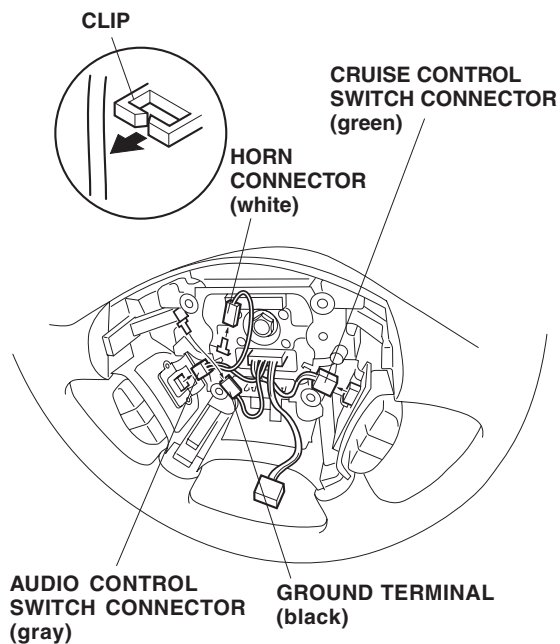

- Release the airbag harness, the audio control switch harness (if equipped), the cruise control switch harness, and the ground terminal from the four clips on the boss plate cover.

- Using a felt-tip pen, mark the top of the steering wheel stud at a position corresponding to the existing mark on the steering wheel.

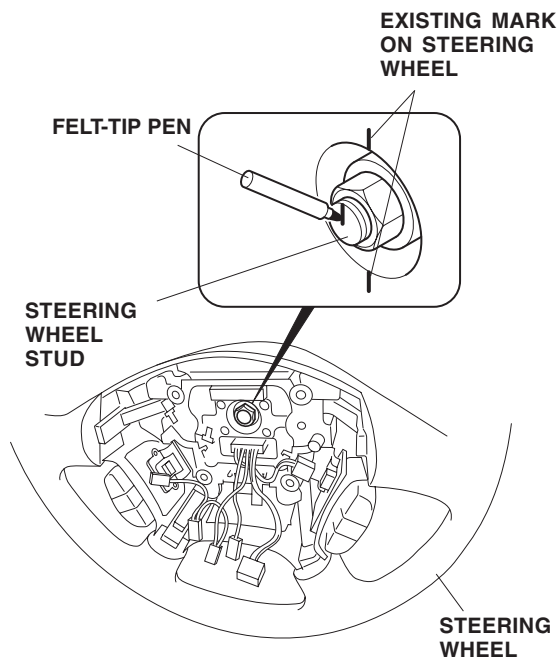

- Remove the steering wheel nut. Slowly and carefully remove the steering wheel while routing the wires through the hole in the steering wheel. Be careful not to move the steering wheel during removal.

If a steering wheel puller is needed to remove the steering wheel, be careful not to thread the steering wheel puller bolts in more than 10 mm.

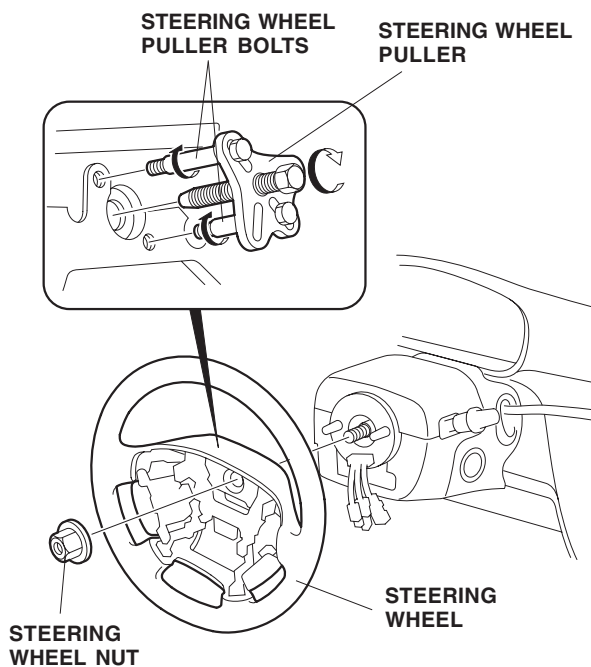

- Using a T40 Torx bit, remove the four Torx bolts that fasten the horn plate to the steering wheel, and remove the horn plate. Discard the four Torx bolts.

If the springs fall out of position from the back of the horn plate, reinstall the blue springs at the two upper holes and the silver springs at the two lower holes.

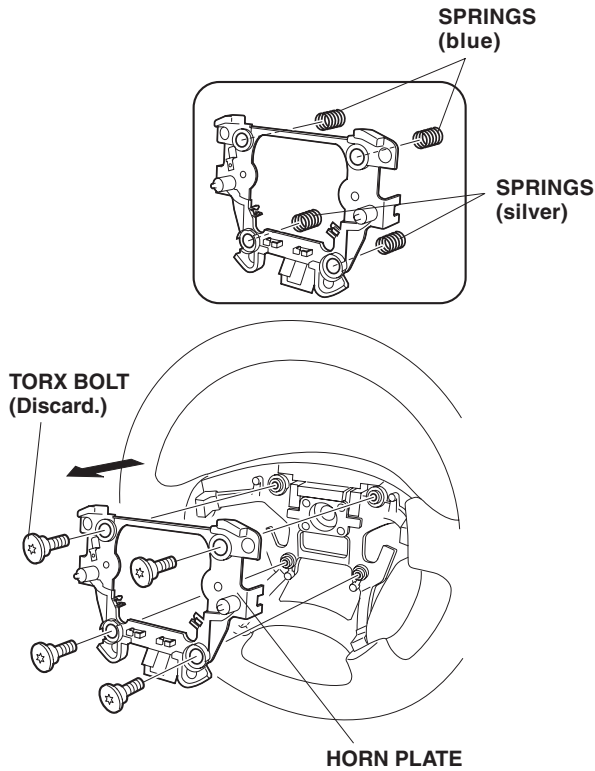

- Remove the steering wheel balance weight (two screws).

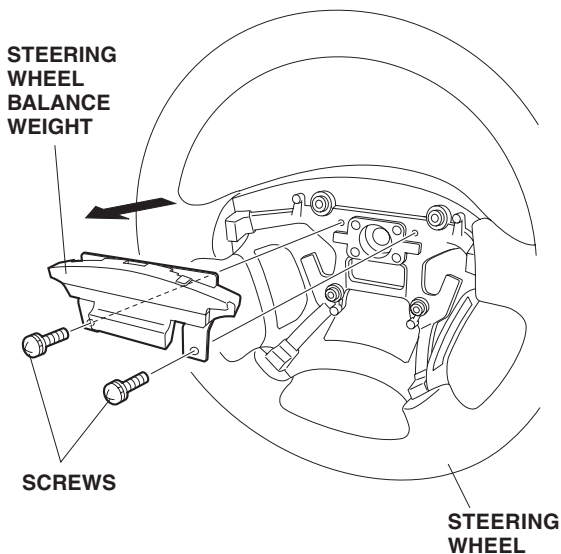

- Remove the two screws that fasten the audio control switch (if equipped) and the two screws that fasten the cruise control switch. Remove the switch(es).

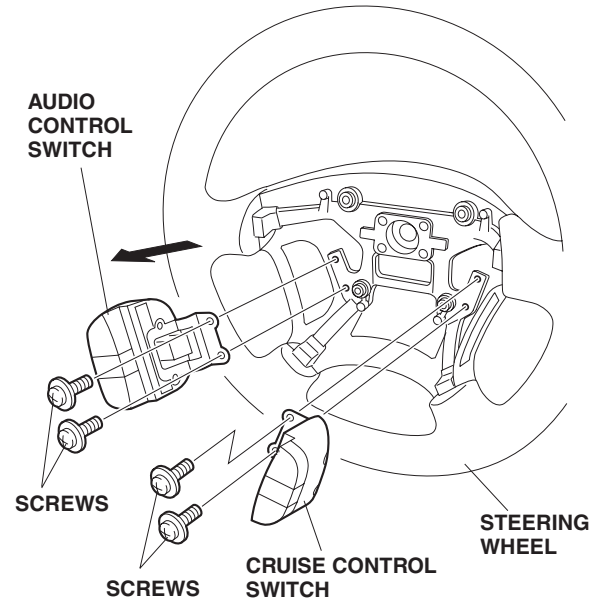

- Remove the steering wheel lower cover from the steering wheel (four screws).

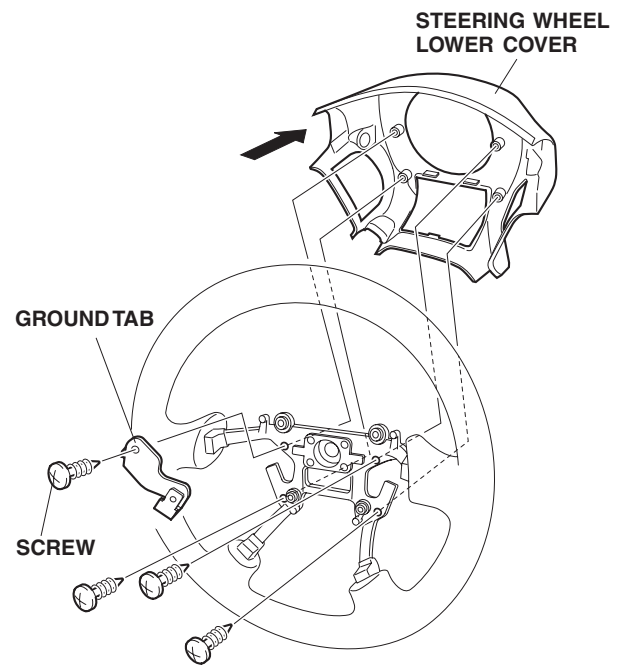

- Remove the ground tab (one screw).

17. Transfer the steering wheel lower cover (four screws) and the ground tab (one screw) to the wood trim steering wheel. Tighten the screws securely.

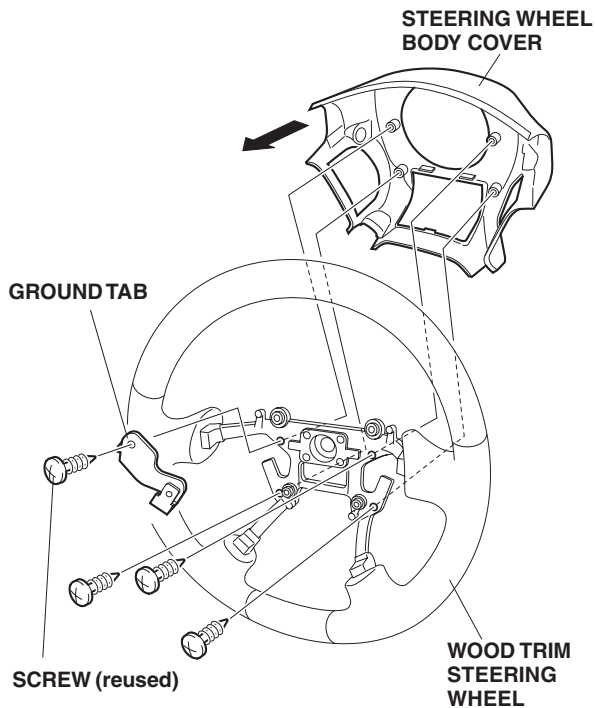

18. Transfer the audio control switch (if equipped) and the cruise control switch to the wood trim steering wheel. Tighten the screws securely.

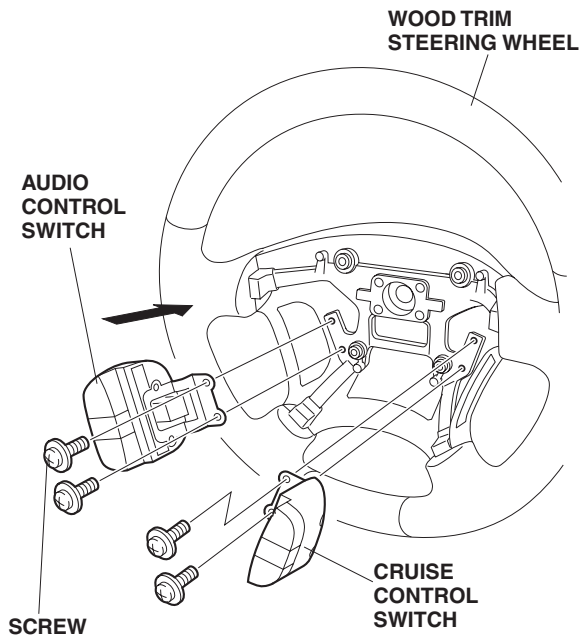

19. Install the steering wheel balance weight onto the wood trim steering wheel with the two screws. Tighten the screws securely.

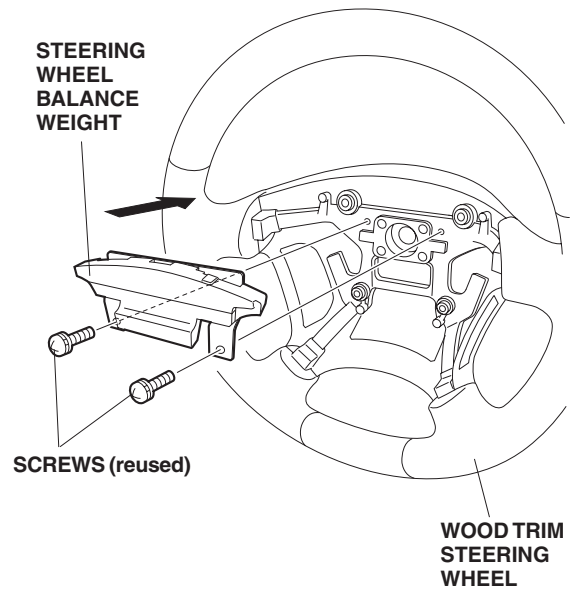

20. Position the horn plate on the wood trim steering wheel, and install the four Torx bolts supplied. Torque the bolts to 4 to 5 N·m (3 to 3.5 lb-ft).

If the springs fall out of position from the back of the horn plate, reinstall the blue springs at the two upper holes and the silver springs at the two lower holes.

NEW TORX BOLT
Torque to 4 to 5 N·m
(3 to 3.5 lb-ft).

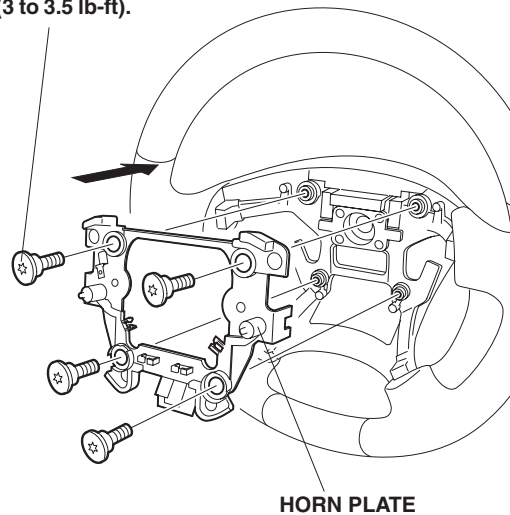

If the cable reel was moved, continue with step 21; if it was not moved, go to step 22.

21. Align the cable reel:

- Rotate the cable reel clockwise all the way until it will no longer move.
- Turn the cable reel counterclockwise about two complete turns until the "TOP" arrow on the cable reel points up.

22. Install the wood trim steering wheel on the steering column shaft in the straight-ahead position:

- Carefully route the wire harnesses through the opening in the wood trim steering wheel.
- Align the two tabs of the canceling sleeve with the two cutouts in the steering wheel as shown.
- Align the mark made on the top of the stud in step 10 with the mark on the wood trim steering wheel.
- Check that the wire harnesses are not pinched.
- Install the steering wheel nut. Torque the steering wheel nut to 49 N·m (36 lb-ft).

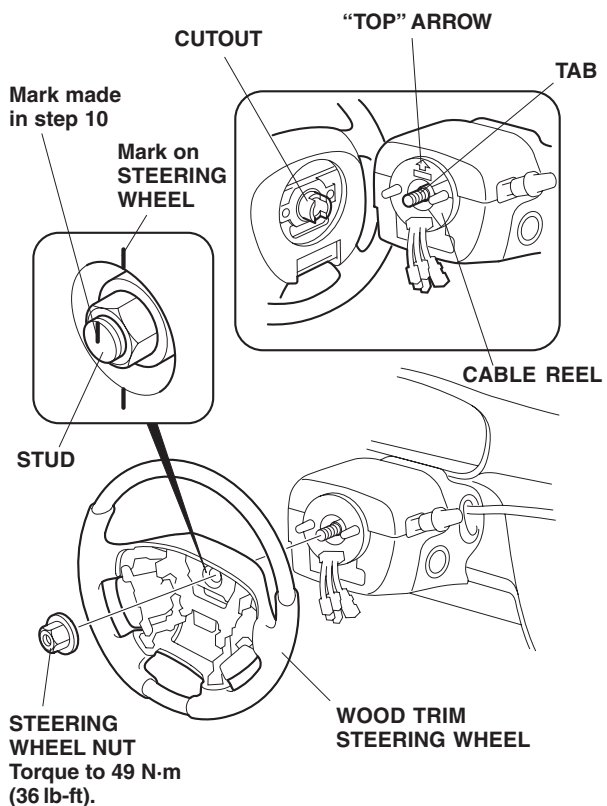

24. Plug in the connectors for the green cruise control switch and the gray audio control switch (if equipped). Connect the black ground terminal to the ground tab, and connect the white horn connector to the horn plate.

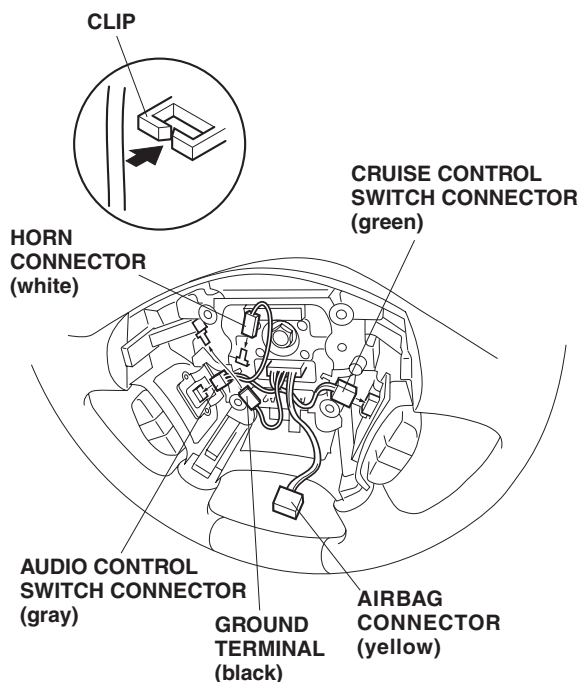

25. Attach the cruise control switch wires, the audio control switch wires, the airbag connector wires, the horn wire, and the ground terminal wire to the wire clips.
26. Get the airbag, and route the airbag harness down through the steering wheel. Position the airbag on the wood trim steering wheel, and install the two Torx bolts supplied. Torque the bolts to 10 N·m (7 lb-ft).

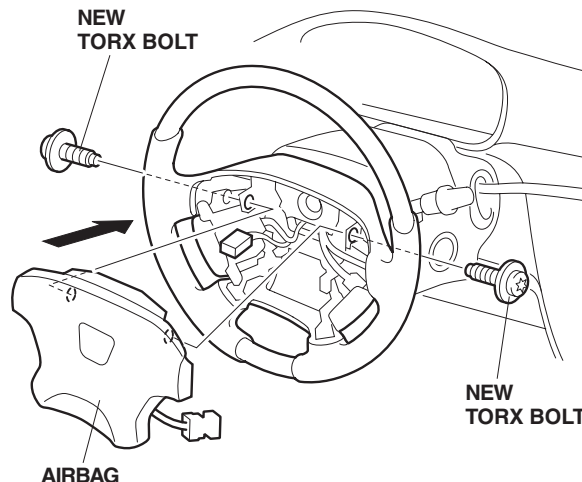

27. Connect the airbag harness connectors:

- Push the socket insulator onto the pin insulator until it contacts the tab on the pin insulator.
- Do not push the socket insulator onto the pin insulator by pushing on the cover insulator.
- Continue pushing on the socket insulator in the same direction until the cover insulator rides over the tab on the pin insulator and is locked securely.
- Reattach the airbag harness connector to the boss plate cover.
- Reinstall the access panel.

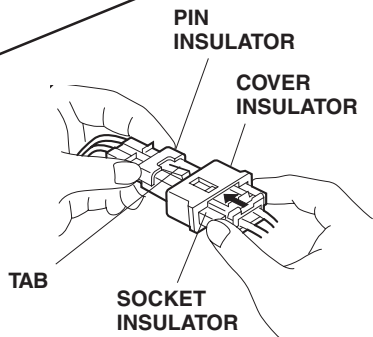
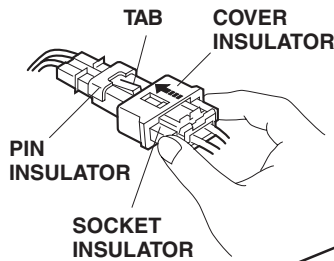
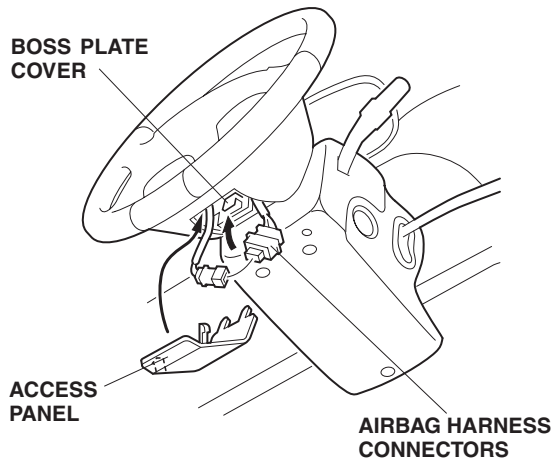

28. Reconnect the negative cable to the battery.

29. Make sure the steering wheel is in the straight-ahead position with the front wheels. If the spoke angle of the steering wheel is not in the straight-ahead position with the front wheels, adjust the front toe as described in the Service Manual.

NOTE: The flat-rate time for installing the steering wheel includes toe adjustment.

30. Verify that the horn works.
31. Turn the ignition switch to ON (II), and verify that the SRS warning light comes on and stays on for 6 seconds. Turn off the ignition switch to make sure the SRS warning light goes off.
32. Enter the customer's radio anti-theft code, and reset the radio station presets.
33. Reset the clock.