

# SERVICE MANUAL

(DOMESTIC & INTERNATIONAL)

## IMPINGER X2 OVENS WITH PUSH BUTTON CONTROLS

**MODEL**

**3240-2, 3262-2, 3270-2**



Lincoln Foodservice Products, LLC  
1111 North Hadley Road  
Fort Wayne, Indiana 46804  
United States of America

Phone: (800) 374-3004  
U.S. Fax: (888) 790-8193 • Int'l Fax: (260) 436-0735

Technical Service Hot Line  
(800) 678-9511

[www.lincolnfp.com](http://www.lincolnfp.com)



## SEQUENCE OF OPERATION IMPINGER X2 OVENS - DOMESTIC WITH PUSH BUTTON CONTROLS

3240-2*	230VAC	60 HZ.	1 PHASE
3240-2*	230VAC	60 HZ.	3 PHASE
3262-2*	230VAC	60 HZ.	1 PHASE
3262-2*	230VAC	60 HZ.	3 PHASE
3270-2*	230VAC	60 HZ.	1 PHASE
3270-2*	230VAC	60 HZ.	3 PHASE

**\*NOTE:**

Model number ending in TS indicates top belt is split belt  
 Model number ending in SB indicates bottom belt is split belt  
 Model number ending in SS indicates both belts are split belts

POWER SUPPLY	Electrical power to be supplied to the oven by a three conductor service for single phase or a four conductor service for three phase. Black conductor is hot. Red conductor is hot. Orange conductor is hot. Green conductor is ground.
MAIN FAN CIRCUIT	Power is permanently supplied to the normally open contacts of the main fan relay. Power is also supplied, through a 3 amp. fuse, to the 30 minute time delay relay. Closing the oven power switch enables the 30 minute time delay relay. The 30 minute time delay relay supplies line voltage to the coil of the main fan relay. These normally open contacts now close energizing the main fan motor. Closing the main power switch also supplies power to the burner and conveyor circuits.
BURNER CIRCUIT	Closing the main power switch supplies line voltage to the oven control transformer. The transformer's secondary supplies 24VAC to the oven control and, through the burner blower air pressure switch, to the burner control. When the burner control is supplied with 24VAC, the pilot valve is energized and the igniter circuit is energized. Ignition should now occur. After the pilot flame is proven, the main gas valve is energized.
TEMPERATURE CONTROL	Closing the main fan switch supplies line voltage to the oven control transformer. The transformer's secondary supplies 24VAC to the oven control. The oven control is set to the desired temperature. The thermocouple will provide varying millivolts to the oven control. The oven control supplies line voltage to the temperature regulation valve at intermittent intervals to maintain desired temperature. The display on the oven control will indicate when the temperature regulation valve is energized. NOTE: The display also indicates oven temperature.
CONVEYOR DRIVE	THE OVEN WILL CONTAIN BETWEEN TWO AND FOUR SEPARATE CONVEYOR DRIVE SYSTEMS. THE SEQUENCE OF OPERATIONS WILL BE THE SAME FOR EACH MOTOR SYSTEM. Closing the main fan switch supplies line voltage, to the conveyor motor and to the primary of the control transformer. Secondary voltage, 24VAC, is supplied to the oven control. Setting the oven control to the desired time, outputs voltage, through a reversing switch, to the conveyor motor. NOTE: The conveyor control uses a hall effect sensor and magnet to prove operation of the conveyor motor. If the conveyor motor is not running, "BELT JAM" is indicated on the display.
AUTOMATIC COOL DOWN	When the oven is started, the 30 minute time delay relay is enabled, permitting the oven fan to operate for approximately 30 minutes after the oven is shut off, to cool the oven. When the oven is shut off, the 30 minute time delay relay will keep the coil of the main fan relay closed for 30 minutes, maintaining operation of the main fan motor.

## SEQUENCE OF OPERATION IMPINGER X2 OVENS - INTERNATIONAL WITH PUSH BUTTON CONTROLS

3240-2*	230VAC	50 HZ.	1 PHASE
3262-2*	230VAC	50 HZ.	1 PHASE
3270-2*	230VAC	50 HZ.	1 PHASE

**\*NOTE:**

Model number ending in TS indicates top belt is split belt  
 Model number ending in SB indicates bottom belt is split belt  
 Model number ending in SS indicates both belts are split belts

POWER SUPPLY	Electrical power to be supplied to the oven by a three conductor service for single phase or a four conductor service for three phase. Black conductor is hot. Red conductor is hot. Orange conductor is hot. Green conductor is ground.
MAIN FAN CIRCUIT	Power is permanently supplied to the normally open contacts of the main fan relay. Power is also supplied, through a 3 amp. fuse, to the 30 minute time delay relay. Closing the oven power switch enables the 30 minute time delay relay. The 30 minute time delay relay supplies line voltage to the coil of the main fan relay. These normally open contacts now close energizing the main fan motor. Closing the main power switch also supplies power to the burner and conveyor circuits.
BURNER CIRCUIT	Closing the oven power switch supplies line voltage, through the air pressure switch and through the oven cavity hi-limit thermostat, to the burner control. The burner control supplies line voltage to the burner blower motor. The normally open air pressure switch closes upon sensing air pressure. The spark and pilot valve are now energized. Ignition should now occur. After the pilot flame is proven, the main gas valve is energized.
TEMPERATURE CONTROL	Closing the main fan switch supplies line voltage, through a filter, to the oven control transformer. The transformer's secondary supplies 24VAC to the oven control. The oven control is set to the desired temperature. The thermocouple will provide varying millivolts to the oven control. The oven control supplies line voltage to the temperature regulation valve at intermittent intervals to maintain desired temperature. The display on the oven control will indicate when the temperature regulation valve is energized. NOTE: The display also indicates oven temperature.
CONVEYOR DRIVE	THE OVEN WILL CONTAIN BETWEEN TWO AND FOUR SEPARATE CONVEYOR DRIVE SYSTEMS. THE SEQUENCE OF OPERATIONS WILL BE THE SAME FOR EACH MOTOR SYSTEM. Closing the main fan switch supplies line voltage, through a filter, to the conveyor motor and, through a filter, to the primary of the control transformer. Secondary voltage, 24VAC, is supplied to the oven control. Setting the oven control to the desired time, outputs voltage, through a reversing switch, to the conveyor motor. NOTE: The conveyor control uses a hall effect sensor and magnet to prove operation of the conveyor motor. If the conveyor motor is not running, "STALL" is indicated on the display.
AUTOMATIC COOL DOWN	When the oven is started, the 30 minute time delay relay is enabled, permitting the oven fan to operate for approximately 30 minutes after the oven is shut off, to cool the oven. When the oven is shut off, the 30 minute time delay relay will keep the coil of the main fan relay closed for 30 minutes, maintaining operation of the main fan motor.

# SCHEMATIC DIAGRAM MODELS 3240-2, 3262-2, 3270-2 60 HZ. WITH PUSH BUTTON CONTROLS

**Lincoln**  
Foodservice Products, Inc.  
FORT WAYNE, INDIANA  
IMPINGER X2-ZS 60 HZ  
2806576C

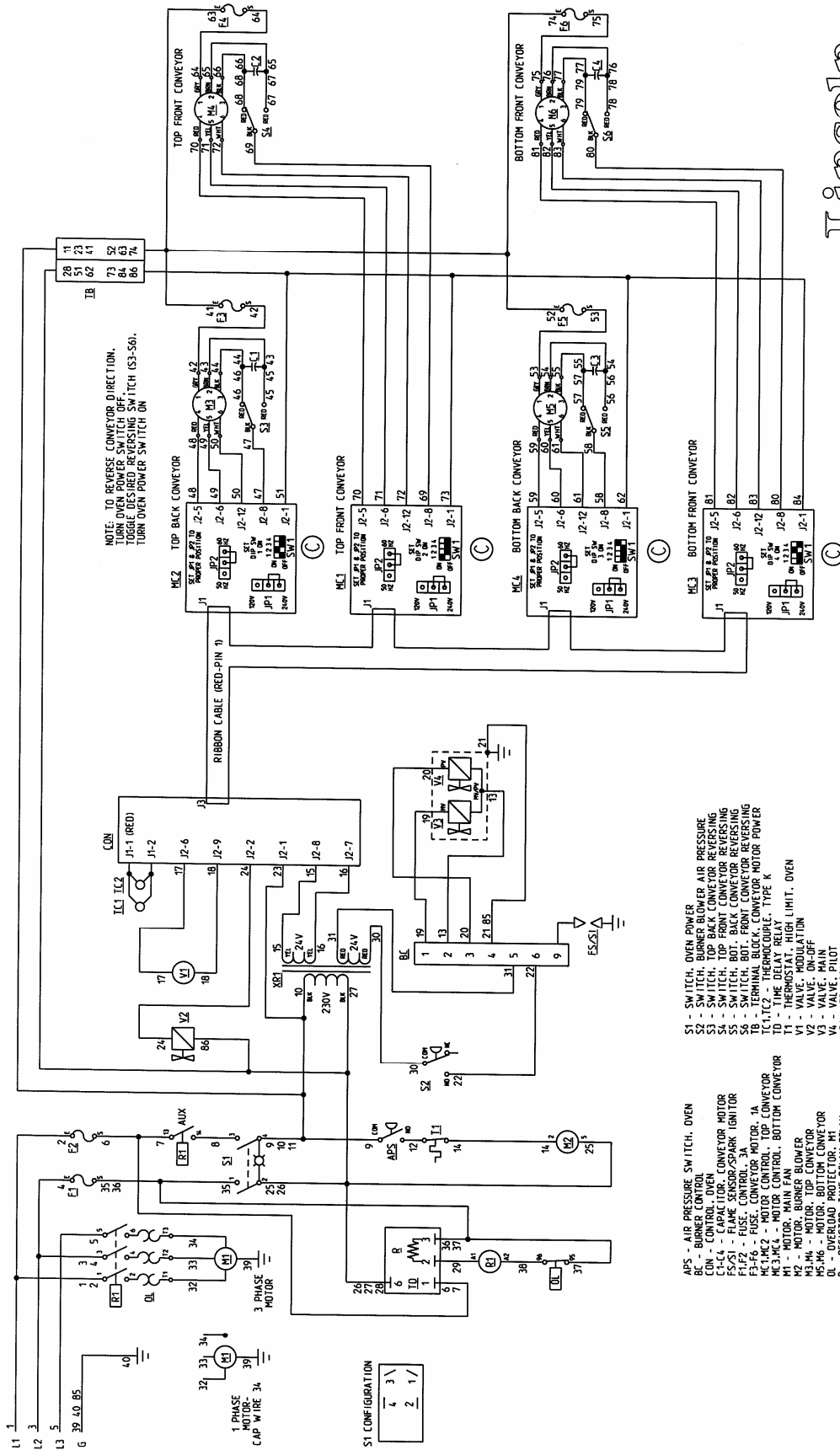

# SCHEMATIC DIAGRAM MODELS 3262-2, 3270-2 50 HZ. WITH PUSH BUTTON CONTROLS

**Lincoln**  
Food Service Products, Inc.  
FORT WAYNE, INDIANA  
IMPINGER X2-2SS 50 HZ  
10000791A

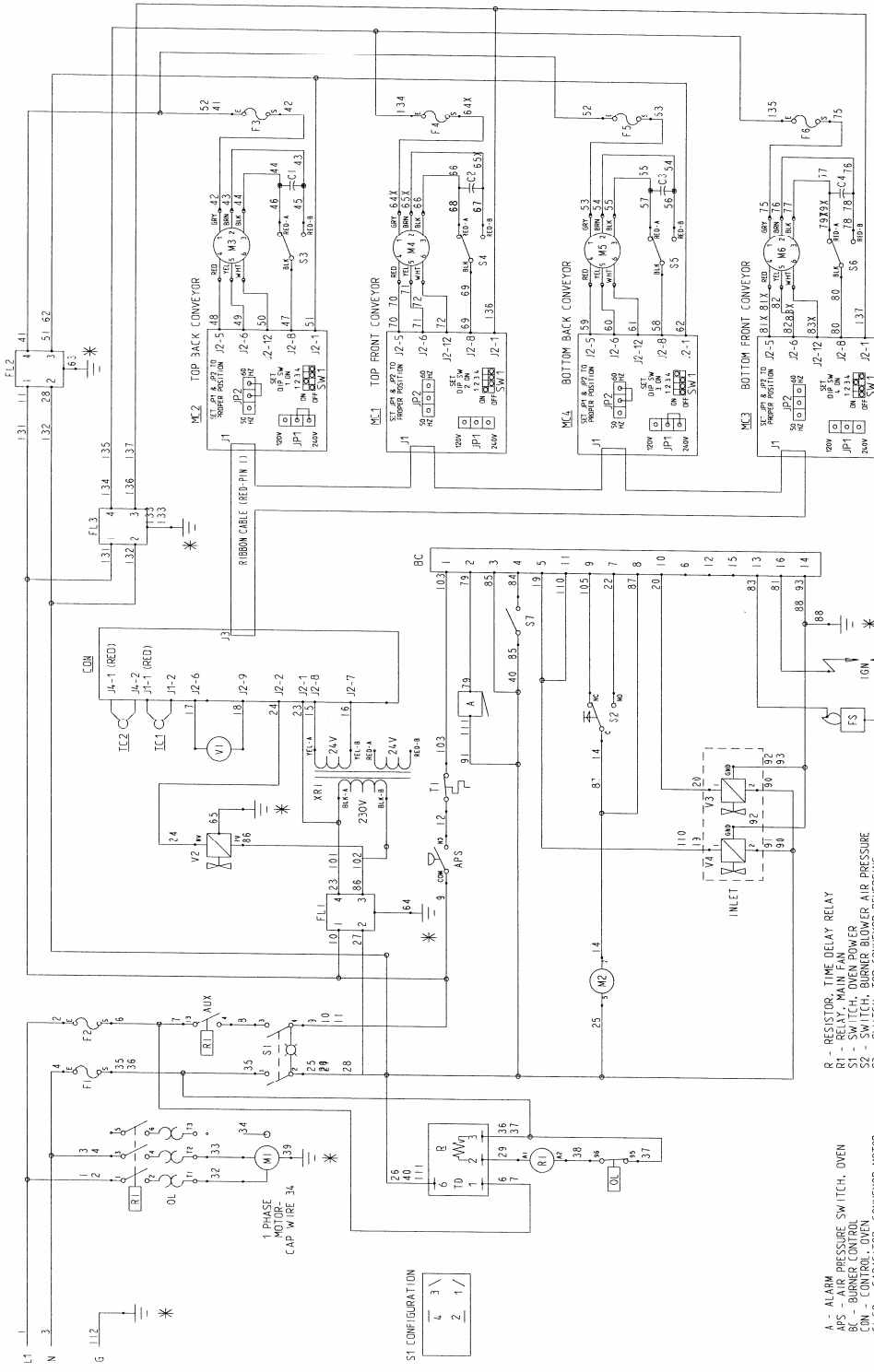

NOTE: TO REVERSE CONVEYOR DIRECTION,  
TOGGLE OVERHEAD REVERSING SWITCH (S3-S4).  
TURN OVEN POWER SWITCH ON

NOTE: \* ALL GROUND WIRES TO TB2

- R - RESISTOR, TIME DELAY RELAY
- R1 - RELAY, MAIN FAN
- S1 - SWITCH, OVEN POWER
- S2 - SWITCH, BURNER BLOWER AIR PRESSURE
- S3 - SWITCH, TOP CONVEYOR REVERSING
- S4 - SWITCH, BOTTOM CONVEYOR REVERSING
- S5 - SWITCH, BURNER RESPIRE
- T1 - THERMOSTAT, BURNER MOTOR POWER
- T2 - THERMOSTAT, CONVEYOR MOTOR POWER
- T3 - THERMOSTAT, THERMOCOUPLE, TYPE K
- T4 - THERMOSTAT, HIGH LIMIT, OVEN
- V1 - VALVE, MODULATION
- V2 - VALVE, ON-OFF
- V3 - VALVE, MAIN
- V4 - VALVE, AIR
- XR1 - TRANSFORMER, OVEN CONTROL

## TROUBLESHOOTING GUIDE - DOMESTIC

3240-2*	230VAC	60 HZ.	1 PHASE
3240-2*	230VAC	60 HZ.	3 PHASE
3262-2*	230VAC	60 HZ.	1 PHASE
3262-2*	230VAC	60 HZ.	3 PHASE
3270-2*	230VAC	60 HZ.	1 PHASE
3270-2*	230VAC	60 HZ.	3 PHASE

\*NOTE:

Model number ending in TS indicates top belt is split belt  
 Model number ending in SB indicates bottom belt is split belt  
 Model number ending in SS indicates both belts are split belts

SYMPTOM	POSSIBLE CAUSE	EVALUATION
Oven fan will not run	Incoming power supply	Check circuit breakers. Reset if required. Call power co. if needed.
	Fuse, 3 Amp, control	Check, replace if necessary.
	Fuse holder	Check, replace if necessary.
	Switch, oven fan	Check continuity between switch terminals. Replace switch as needed.
	30 minute time delay relay	Check for supply voltage to 30 minute time delay relay at terminals #1 and #3. If no voltage is present, trace wiring back to main power switch. If there is supply voltage at terminals #1 and #3, check for output voltage at terminals #2 and #3. If there is incoming voltage but no output voltage, and the main power switch is on, replace the 30 minute time delay relay.
	Relay, main fan	Check for supply voltage to relay contacts, if no voltage is present, trace wiring back to power supply. Check for 208/240VAC to the coil of the main fan relay. If no voltage is present, trace wiring back to the 30 minute time delay relay, check to be sure that the Overload Protector contacts are closed. If contacts are open, see "Overload Protector" below. If voltage is present, check to insure relay contacts are closing. Replace relay as needed.
	Overload protector, main fan	Check to be sure overload contacts are closed. If not closed, re-set overload. If contacts do not close, replace overload protector. If contacts close, test for proper operation. If the overload contacts do not stay closed, and the amperage is below the overload setting, replace the overload protector. 3240 should be set at 13A 3262 should be set at 18A 3270 should be set at 18A
	Main fan motor	Check for supply voltage at motor. If no voltage is present, trace wiring back to the overload protector. WITH POWER OFF: Check for opens, shorts or grounds. Turn motor shaft to check for locked rotor.
	Capacitor	Check for shorts or grounds.  WARNING: Capacitor has a stored charge, discharge before testing.
	Drive belt	Check for loose or broken drive belt. Adjust motor for proper belt tension (maximum of 3/8-inch deflection), or replace drive belt as needed.
Bearings, Fan shaft	Check for any damage or excessive wear on the shaft bearings. Replace bearings as needed.	

Oven will not heat	Gas supply	Check for adequate gas supply to oven.
	Manual gas shut off valve	Check to see that the manual gas shut off valve is open. Also, check flexible gas line connection for any damage.
	Main fan motor	Check for main fan operation. If it is not operating, refer to "Oven fan will not run".
	Relay, main fan	Check for 208/240VAC supplied to relay terminal #13. If voltage is not present, trace wiring back to power supply. If voltage is present, check for 208/240VAC at terminal #14. If there is no voltage at terminal #14, and the relay is energized, replace the main fan relay.
	Air pressure switch, Main fan motor	Check for 208/240VAC to the air pressure switch. If no voltage is present, trace wiring back to main fan switch. This normally open switch should close when the main fan is activated. Check air switch tube for blockage or any obstructions, repair as needed. Refer to the "Removal and installation" section for proper adjustment of air pressure switch. Replace air pressure switch as needed.
	Hi-limit thermostat, oven cavity	Terminals are normally closed. If open, reset thermostat and retest. If thermostat will not hold for maximum oven temperature, and oven is not exceeding temperature setting, check for proper location of capillary bulb in its spring holder. If the capillary checks okay, replace the hi-limit thermostat.
	Transformer, burner/control	Check for 208/240VAC supplied to primary of transformer. If no voltage is present, trace wiring back to the main fan switch. If voltage is present, check for 24VAC at transformer secondary. NOTE: This is a dual secondary transformer, it is important to check BOTH 24VAC outputs. If there is primary voltage but no secondary voltage, replace burner/control transformer.
	Motor, burner blower	Check for 208/240VAC supplied to the burner blower motor. If no voltage is present, trace wiring back to the hi-limit thermostat. If voltage is present, and the motor is not turning, check for opens, shorts or grounds. WITH POWER OFF: Check for locked rotor. Replace burner blower motor as needed.
	Air pressure switch, burner blower motor	Check for 24VAC to the air pressure switch. If no voltage is present, trace wiring back to the burner/control transformer. This normally open switch should close when the burner blower motor is activated. Check air switch tube for blockage or any obstructions, repair as needed. Refer to the "Removal and installation" section for proper adjustment of air pressure switch. Replace air pressure switch as needed.
	Burner control	Check for 24VAC supply to the ignition control. If no voltage is present, trace wiring back to centrifugal switch of burner blower motor. If voltage is present, check for 24VAC at pin #3 and ground (pilot valve). NOTE: The Honeywell ignition control has a 30 second pre-purge (time delay) built in. If voltage is not present, replace ignition control. If the pilot valve is energized, check to see that the high voltage igniter circuit is also energized. To check, turn power off, disconnect the igniter lead from the ignition control. Turn power on. If no spark is visible, replace burner control. If a spark is visible at burner control, proceed.
	Pilot valve	Check for 24VAC supplied to pilot valve. If no voltage is

		present, trace wiring back to burner control. If voltage is present, check for gas pressure at the pilot line connection. If no gas pressure is present during ignition, check for any blockage in the assembly. If there are no obstructions, and there is gas supplied to the oven, replace the gas valve.
	No pilot flame	If the ignition control is supplied with 24VAC and the pilot valve and igniter circuits are energized, visually check for a pilot flame. This may be done by looking through the inspection view port on the end of the burner. If no pilot flame is visible, check the pilot tube.
	Pilot tube	Check for gas pressure at the pilot tube. Disconnect pilot tube at the burner And connect manometer to pilot tube. If no gas pressure is present during ignition, check for blockage of the pilot tube. If the pilot tube is clear, proceed.
	Pilot orifice	If there is gas pressure at the pilot tube, check the pilot orifice for blockage or obstructions. Replace pilot orifice as needed.
	Burner igniter	Check the burner igniter head for any damage or obstructions also check for frayed or broken wire. Check spark gap, gap should be 3/32" If there is visible damage, replace burner igniter.
	NOTE: Flame should be on at this time	
Low flame is on, but no main flame	Transformer, burner/control	Check for 208/240VAC supplied to primary of transformer. If no voltage is present, trace wiring back to the main fan switch. If voltage is present, check for 24VAC at transformer secondary. NOTE: This is a dual secondary transformer, it is important to check BOTH 24VAC outputs. If there is primary voltage but no secondary voltage, replace burner/control transformer.
	Oven control	Check for 24VAC supply to oven control. If no voltage is present, trace wiring back to control transformer. If 24VAC is present, check for a read-out on the display. If there is 24VAC supplied, but there is no read-out on the display, replace oven control. If there is a read-out on the control, set the control to maximum temperature (see Installation operations manual for temperature adjustment). With the control set at maximum temperature, check for 208/240VAC at the temperature regulation valve. If there is voltage at the temperature regulation valve, proceed to "Temperature regulation valve" for next check. If there is no voltage at the temperature regulation valve, trace wiring back to the oven control. If there is no voltage output at the oven control, check the read-out on the oven control. If the control reads "PROBE FAIL", this indicates that the thermocouple has failed or become disconnected from the oven control.
	Thermocouple probe	Check to be sure that the thermocouple is securely connected to the oven control. If the thermocouple is connected to the oven control, and the control indicates "PROBE FAIL", disconnect the thermocouple from the oven control and measure the resistance of the thermocouple. The thermocouple should read approx. 11Ω. If these readings are not achieved, replace the thermocouple. If these readings are correct, proceed.
	Oven control	If the thermocouple checks good, but the oven control display indicates that there is a thermocouple failure,



		replace the oven control. If the oven control indicates a temperature reading, but the oven will not heat, proceed.
	Main gas valve	Check to see that the switch on the valve is in the "ON" position. Check for 24VAC supplied to main valve. If there is voltage present, check to see that valve is opening. Connect manometer to pressure tap on outlet side of valve. If there is voltage to the valve, but no output gas pressure, replace the valve.
	Temperature regulation valve	Check for 208/240VAC at temperature regulation valve. If no voltage is present, trace wiring back to electronic temperature control. If voltage is present, listen for valve to open and close. Also check for opens or shorts in the operating coil. Replace temperature regulation valve as needed.
	Oven control	Check for 3 – 24VDC from the oven control at terminals #J2-6 and J2-9. If there is no output voltage, replace oven control. If there is output voltage, Proceed.
	Modulating valve	Check for 3-24VDC at the modulating valve. If no voltage is present, trace wiring back to the oven control. If voltage is present, listen for valve to open and close. Also check for opens or shorts in the operating coil. Replace modulating valve as needed.
Intermittent heating	Thermal/Overload of main fan and burner blower motors	The main fan motor and burner blower motor are equipped with internal thermal protection and will cease to operate if overheating occurs. As the motors over-heat and then cool, this will cause the units to cycle on and off intermittently. Improper ventilation or lack of preventive maintenance may cause this. Also, most of the problems listed under "Oven will not heat" can cause intermittent failure.
Conveyor will not run	NOTE: The ovens may contain two, three or four conveyor drive systems using like components. The trouble shooting sequence will be the same for each of the conveyor drive systems	
	Power supply	Check circuit breakers, reset if required. Check power plug to be sure it is firmly in receptacle. Measure incoming power, call power co. if needed.
	Switch, oven power	Check continuity between switch terminals. Replace switch as needed.
	Relay, main fan	Check for 120VAC supplied to relay terminal #13. If voltage is not present, trace wiring back to power supply. If voltage is present, check for 120VAC at terminal #14. If there is no voltage at terminal #14, and the relay is energized, replace the main fan relay.
	Transformer, burner/control	Check for 208/240VAC supplied to primary of transformer. If no voltage is present, trace wiring back to the main fan switch. If voltage is present, check for 24VAC at transformer secondary. NOTE: This is a dual secondary transformer, it is important to check BOTH 24VAC outputs. If there is primary voltage but no secondary voltage, replace burner/control transformer.
	Switch, conveyor reversing	Check for continuity between switch terminals. Replace switch as needed.
	Conveyor motor	Check for 208/240VAC supplied to the motor. If no voltage is present, trace wiring back to the reversing switch. If voltage is present, check motor windings for opens or shorts.

		<p>WITH POWER OFF: Check the motor windings as follows:          Grey to Black – 114 ohm approx.          Grey to Brown – 114 ohm approx.          Brown to Black – 228 ohm approx.          If any of the above fail, replace motor.</p>
	Capacitor, conveyor motor	<p>Check for shorts or grounds. Replace capacitor as needed.  <b>WARNING:</b> Capacitor has a stored charge, discharge before testing.</p>
	Conveyor	<p>Check for any mechanical problems in the conveyor assembly. Check for damaged or torn belting. Check conveyor shaft bearings for damage or excessive wear. Repair or replace conveyor components as needed.</p>
	Oven control	<p>If there is voltage supplied to the motor, and the motor, capacitor, and reversing switch check good, replace the oven control.</p>
Conveyor motor runs, but there is no speed display	NOTE: Display will indicate "STALL"	
	Oven control	<p>Check output voltage from oven control to hall effect sensor (sensor is located in conveyor motor). Measure voltage at the motor connector, red wire and yellow wire. Voltage should be approx. 10VDC. If no voltage is present, trace wiring back to the oven control. If there is no voltage output present at the oven control, replace the oven control.</p>
	Motor, conveyor	<p>If there is voltage supplied to the hall effect sensor, check for a frequency output from the hall effect sensor. Measure frequency across the yellow and white wires at the motor connector. Frequency readings should be between 15 Hz-500 Hz. If these readings are not achieved, replace conveyor motor. If these readings are achieved, proceed.</p>
	Oven control	<p>If the hall effect sensor readings are correct, but there is no speed indicated on the display, replace the control.</p>

## TROUBLESHOOTING GUIDE - INTERNATIONAL

3240-2*	230VAC	50 HZ.	1 PHASE
3262-2*	230VAC	50 HZ.	1 PHASE
3270-2*	230VAC	50 HZ.	1 PHASE

\*NOTE:

Model number ending in TS indicates top belt is split belt  
 Model number ending in SB indicates bottom belt is split belt  
 Model number ending in SS indicates both belts are split belts

SYMPTOM	POSSIBLE CAUSE	EVALUATION
Oven fan will not run	Incoming power supply	Check circuit breakers. Reset if required. Call power co. if needed.
	Fuse, 3 Amp, control	Check, replace if necessary.
	Fuse holder	Check, replace if necessary.
	Switch, oven fan	Check continuity between switch terminals. Replace switch as needed.
	30 minute time delay relay	Check for supply voltage to 30 minute time delay relay at terminals #1 and #3. If no voltage is present, trace wiring back to fuse holder. If there is supply voltage at terminals #1 and #3, check for output voltage at terminals #2 and #3. If there is incoming voltage but no output voltage, and the main power switch is on, replace the 30 minute time delay relay.
	Relay, main fan	Check for supply voltage to relay contacts, if no voltage is present, trace wiring back to power supply. Check for supply voltage to the coil of the main fan relay. If no voltage is present, trace wiring back to the 30 minute time delay relay, check to be sure that the Overload Protector contacts are closed. If contacts are open, see "Overload Protector" below. If voltage is present, check to insure relay contacts are closing. Replace relay as needed.
	Overload protector, main fan	Check to be sure overload contacts are closed. If not closed, re-set overload. If contacts do not close, replace overload protector. If contacts close, test for proper operation. If the overload contacts do not stay closed, and the amperage is below the overload setting, replace the overload protector. 3240 should be set at 13A 3262 should be set at 18A 3270 should be set at 18A
	Main fan motor	Check for supply voltage at motor. If no voltage is present, trace wiring back to the overload protector. WITH POWER OFF: Check for opens, shorts or grounds. Turn motor shaft to check for locked rotor.
	Capacitor	Check for shorts or grounds.  WARNING: Capacitor has a stored charge, discharge before testing.
Oven will not heat	Drive belt	Check for loose or broken drive belt. Adjust motor for proper belt tension (maximum of 3/8-inch deflection), or replace drive belt as needed.
	Bearings, Fan shaft	Check for any damage or excessive wear on the shaft bearings. Replace bearings as needed.
	Gas supply	Check for adequate gas supply to oven.
	Manual gas shut off valve	Check to see that the manual gas shut off valve is open. Also, check flexible gas line connection for any

		damage.
	Main fan motor	Check for main fan operation. If it is not operating, refer to "Oven fan will not run".
	Relay, main fan	Check for supply voltage to relay terminal #13. If voltage is not present, trace wiring back to power supply. If voltage is present, check for supply voltage at terminal #14. If there is no voltage at terminal #14, and the relay is energized, replace the main fan relay.
	Air pressure switch, Main fan motor	Check for supply voltage to the air pressure switch. If no voltage is present, trace wiring back to main fan switch. This normally open switch should close when the main fan is activated. Check air switch tube for blockage or any obstructions, repair as needed. Refer to the "Removal and installation" section for proper adjustment of air pressure switch. Replace air pressure switch as needed.
	Hi-limit thermostat, oven cavity	Terminals are normally closed. If open, reset thermostat and retest. If thermostat will not hold for maximum oven temperature, and oven is not exceeding temperature setting, check for proper location of capillary bulb in its spring holder. If the capillary checks okay, replace the hi-limit thermostat.
	Burner control	Check for supply voltage to burner control at terminal #1 and Neutral. If no voltage is present, trace wiring back to hi-limit thermostat. If voltage is present, check for supply voltage to burner blower motor at terminal #8 and neutral. If no voltage is present, wait thirty seconds, reset burner control, and re-try. If the above fails, replace burner control.
	Burner reset switch.	Switch is normally open, check to see that the switch closes when reset button is pushed. Replace switch as needed.
	Motor, burner blower	Check for supply voltage to the burner blower motor. If no voltage is present, trace wiring back to the burner control. If voltage is present, and the motor is not turning, check for opens, shorts or grounds. WITH POWER OFF: Check for locked rotor. Replace burner blower motor as needed.
	Air pressure switch, burner blower motor	Check for air pressure switch to be switching from "NC" to "NO". Check for air tube blockage or misalignment. Replace air pressure switch as needed.
	Burner control	A pre-purge time of 30 – 60 seconds occurs after burner blower motor starts. Check for high voltage spark output from the burner control. If there is no high voltage spark output, check reset button for the burner control. If there is still no high voltage output, replace the burner control.
	Igniter/sensor assembly	Check for visible damage to the igniter/sensor assembly. If there is visible damage, replace components as needed. If there is no visible damage to the components, and there is no spark, replace the igniter/sensor assembly. Also check for damaged wires in the burner tube. Replace components as needed.
	Burner control	Gas valve should open as the burner control generates the high voltage spark. Check for supply voltage to pilot valve at terminal #5 and neutral. If no voltage is present, check reset button for the burner control. If there is still no voltage the pilot valve, replace burner control
	Gas valve	Check for supply voltage at the pilot valve. If no voltage is present, trace wiring back to the burner control. If

		there is voltage, connect a manometer to the pressure tap fitting on the gas valve. If there is voltage to the pilot valve, but there is no gas pressure, replace gas valve.
	Pilot tube	Check for gas pressure at pilot tube. Disconnect pilot tube at burner and connect manometer. If there is no gas pressure, check for blockage in pilot tube. Repair or replace tube as needed.
	Pilot orifice	If there is gas pressure at the pilot tube, check the pilot orifice for blockage or obstructions. Replace pilot orifice as needed.
Flame will not stay on	Flame sensor	To check flame sensor operation, connect a digital multimeter (capable of measuring D.C. Microamps) between the flame sensor wire and the flame sensor connection on the ignition control (terminal #3). Flame sensor current is to be 0.7 microamp, minimum. If these readings are not achieved, replace igniter/sensor assembly. Also check for any type of damage to flame sensor wire and connections. NOTE: The D.C. microamp test must be conducted with the oven in low flame operation.
	Power supply	Set the temperature to the lowest temperature setting. If there is sufficient microamp current, but the flame will not stay lit, check for proper polarity of the power supply.
	Burner control	If there is sufficient microamp current, and there is proper polarity of the power supply, but the burner will not stay lit, check the reset button for the burner control. If the above test is okay, replace the burner control.
	NOTE: Flame should be on at this time	
Low flame is on, but no main flame	Transformer, control	Check for supply voltage to primary of control transformer. If no voltage is present, trace wiring back to the main fan switch. If voltage is present, check for 24VAC at transformer secondary. If there is primary voltage but no secondary voltage, replace burner/control transformer.
	Oven control	Check for 24VAC supply to oven control. If no voltage is present, trace wiring back to control transformer. If 24VAC is present, check for a read-out on the display. If there is 24VAC supplied, but there is no read-out on the display, replace oven control. If there is a read-out on the control, set the control to maximum temperature (see Installation operations manual for temperature adjustment). With the control set at maximum temperature, check for supply voltage at the temperature regulation valve. If there is voltage at the temperature regulation valve, proceed to "Temperature regulation valve" for next check. If there is no voltage at the temperature regulation valve, trace wiring back to the oven control. If there is no voltage output at the oven control, check the read-out on the oven control. If the control reads "PROBE FAIL", this indicates that the thermocouple has failed or become disconnected from the oven control.
	Thermocouple probe	Check to be sure that the thermocouple is securely connected to the oven control. If the thermocouple is connected to the oven control, and the control indicates "PROBE FAIL", disconnect the thermocouple from the oven control and measure the resistance of the

		thermocouple. The thermocouple should read approx. 11Ω. If these readings are not achieved, replace the thermocouple. If these readings are correct, proceed.
	Oven control	If the thermocouple checks good, but the oven control display indicates that there is a thermocouple failure, replace the oven control. If the oven control indicates a temperature reading, but the oven will not heat, proceed.
	Main gas valve	Check to see that the switch on the valve is in the "ON" position. Check for supply voltage to main valve. If there is voltage present, check to see that valve is opening. Connect manometer to pressure tap on outlet side of valve. If there is voltage to the valve, but no output gas pressure, replace the valve.
	Temperature regulation valve	Check for supply voltage at temperature regulation valve. If no voltage is present, trace wiring back to electronic temperature control. If voltage is present, listen for valve to open and close. Also check for opens or shorts in the operating coil. Replace temperature regulation valve as needed.
	Oven control	Check for 3 – 24VDC from the oven control at terminals #J2-6 and J2-9. If there is no output voltage, replace oven control. If there is output voltage, Proceed.
	Modulating valve	Check for 3-24VDC at the modulating valve. If no voltage is present, trace wiring back to the oven control. If voltage is present, listen for valve to open and close. Also check for opens or shorts in the operating coil. Replace modulating valve as needed.
Intermittent heating	Thermal/Overload of main fan and burner blower motors	The main fan motor and burner blower motor are equipped with internal thermal protection and will cease to operate if overheating occurs. As the motors over-heat and then cool, this will cause the units to cycle on and off intermittently. Improper ventilation or lack of preventive maintenance may cause this. Also, most of the problems listed under "Oven will not heat" can cause intermittent failure.
Conveyor will not run	NOTE: The ovens may contain two, three or four conveyor drive systems using like components. The trouble shooting sequence will be the same for each of the conveyor drive systems	
	Power supply	Check circuit breakers, reset if required. Check power plug to be sure it is firmly in receptacle. Measure incoming power, call power co. if needed.
	Switch, oven power	Check continuity between switch terminals. Replace switch as needed.
	Relay, main fan	Check for supply voltage to relay terminal #13. If voltage is not present, trace wiring back to power supply. If voltage is present, check for supply voltage at terminal #14. If there is no voltage at terminal #14, and the relay is energized, replace the main fan relay.
	Transformer, control	Check for supply voltage to primary of transformer. If no voltage is present, trace wiring back to the main fan switch. If voltage is present, check for 24VAC at transformer secondary. If there is primary voltage but no secondary voltage, replace burner/control transformer.
	Switch, conveyor reversing	Check for continuity between switch terminals. Replace switch as needed.
	Conveyor motor	Check for supply voltage to the motor. If no voltage is

		<p>present, trace wiring back to the reversing switch. If voltage is present, check motor windings for opens or shorts.</p> <p>WITH POWER OFF: Check the motor windings as follows:</p> <p>Grey to Black - 114 ohm approx.</p> <p>Grey to Brown - 114 ohm approx.</p> <p>Brown to Black - 228 ohm approx.</p> <p>If any of the above fail, replace motor.</p>
	Capacitor, conveyor motor	<p>Check for shorts or grounds. Replace capacitor as needed.</p> <p>WARNING: Capacitor has a stored charge, discharge before testing.</p>
	Conveyor	<p>Check for any mechanical problems in the conveyor assembly. Check for damaged or torn belting. Check conveyor shaft bearings for damage or excessive wear. Repair or replace conveyor components as needed.</p>
	Oven control	<p>If there is voltage supplied to the motor, and the motor, capacitor, and reversing switch check good, replace the oven control.</p>
Conveyor motor runs, but there is no speed display	NOTE: Display will indicate "STALL"	
	Oven control	<p>Check output voltage from oven control to hall effect sensor (sensor is located in conveyor motor). Measure voltage at the motor connector, red wire and yellow wire. Voltage should be approx. 10VDC. If no voltage is present, trace wiring back to the oven control. If there is no voltage output present at the oven control, replace the oven control.</p>
	Motor, conveyor	<p>If there is voltage supplied to the hall effect sensor, check for a frequency output from the hall effect sensor. Measure frequency across the yellow and white wires at the motor connector. Frequency readings should be between 15 Hz-500 Hz. If these readings are not achieved, replace conveyor motor. If these readings are achieved, proceed.</p>
	Oven control	<p>If the hall effect sensor readings are correct, but there is no speed indicated on the display, replace the control.</p>

# REMOVAL, INSTALLATION & ADJUSTMENTS

## IMPINGER X2 SERIES OVENS

### CAUTION!

BEFORE REMOVING OR INSTALLING ANY COMPONENT IN THE IMPINGER X2 OVEN BE SURE TO DISCONNECT ELECTRICAL POWER AND GAS SUPPLY

### MOTOR, MAIN FAN - REPLACEMENT

1. Shut off power at main breaker.
2. Remove control box cover and control box rear cover.
3. Disconnect motor wiring and mark all wiring for reassembly.
4. Remove V-belt by loosening the four bolts on the motor mount plate and the two belt tensioning bolts.
5. Remove motor and motor mount assembly. Remove motor from motor mount. Remove pulley from motor and install pulley on new motor.
6. Reassemble in reverse order and check system operation. Be sure to check for proper tension on drive belt. Adjust tension bolts until there is no more than 3/8 inch deflection at the halfway point between the motor pulley and the driven pulley.

### SHAFT AND BLOWER WHEEL – REPLACEMENT

1. Shut off power at main breaker.
2. Remove cover panels from both sides.
3. Remove back.
4. Unbolt blower housings
5. Remove thermocouple from mount
6. Remove flanges from blower housing ( mark position of flange for replacement)

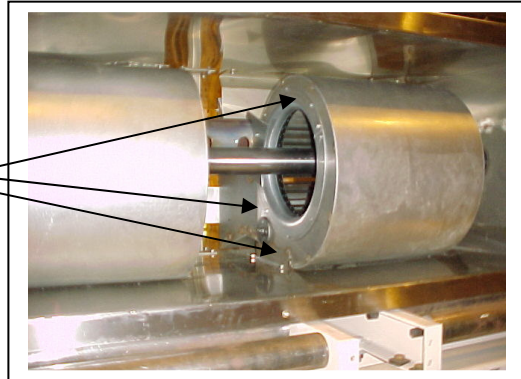

7. Unbolt air return panels from inside top
8. Remove sheet metal from plenum





9. Remove burner tube bracket and Burner tube.  
To remove burner tube, Remove cap from idle end of Oven wall and remove burner tube.

10. Measure distance from end of shaft to the collar
11. of blower wheel. Loosen blower wheels from shaft. (1/4" allen screws - use liquid wrench)  
Push blower wheels toward idle end.

12. Loosen and remove idle and drive end bearings.

13. Remove shaft and blower wheel assemblies. (measure length of shaft extension from oven wall. Use same measurement when putting new shaft in)  
Remove shaft through idle end of oven.

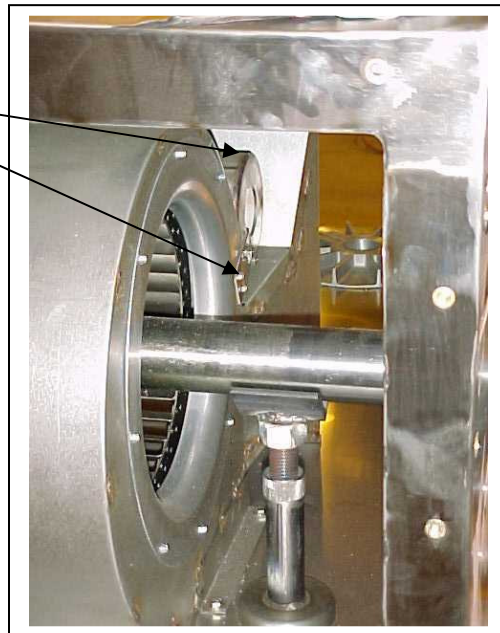

**13.NOTE: When putting new shaft and blower wheels back in, the wheels will have to be removed from the shaft. It is important to mark the blowers left and right and to mark the positioning of the blowers on the shaft so as to maintain spacing and balance.**

When replacing the burner tube, the top of the holes in the burner tube should be 12 3/8" from the bottom of the oven.

1. When replacing the expansion bearing in the drive end, be sure the yoke of the bearing is pushed as far as possible towards the oven wall and tightened on the shaft. This will allow the bearing to expand outward.

Align pulley on drive end of shaft with pulley on drive motor. Grease bearings before starting oven.

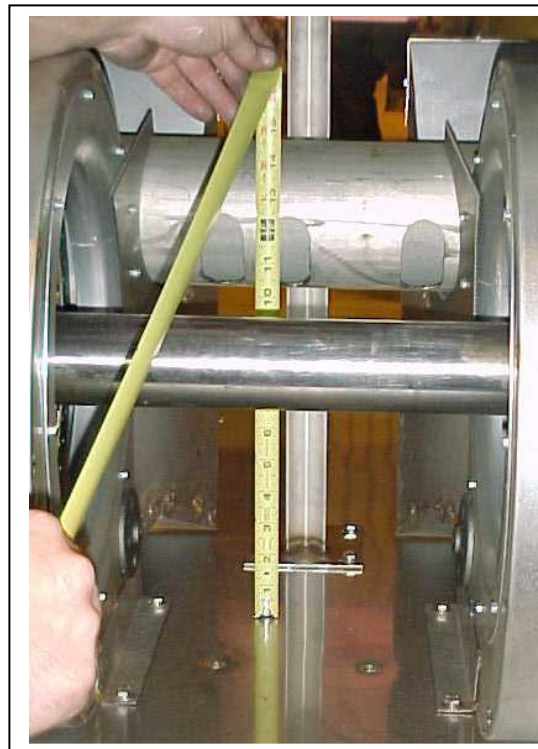

#### RELAY, MAIN FAN, - REPLACEMENT

1. Shut off power at main breaker.
2. Remove control box cover.
3. Disconnect all wiring from relay and mark all wiring for reassembly.
4. Remove main relay and overload protector.
5. Remove overload protector from main relay and mount overload protector on new relay.
6. Reassemble in reverse order and check system for proper operation.

#### TIMER, 30 MINUTE COOL DOWN – REPLACEMENT

1. Shut off power at main breaker.
2. Remove control box cover.
3. Disconnect all wiring from 30-minute cool down timer and mark all wires for reassembly.
4. Remove one mounting bolt and remove 30-minute cool down timer.
5. Reassemble in reverse order and check system operation.

#### FUSE HOLDER – REPLACEMENT

1. Shut off power at main breaker.
2. Remove control box cover.
3. Disconnect wiring from fuse holder and mark all wiring for reassembly.
4. Remove mounting nut from fuse holder and remove fuse holder.
5. Reassemble in reverse order and check system operation.

#### SWITCH, ON/OFF – REPLACEMENT

1. Shut off power at main breaker.
2. Remove control box cover.
3. Disconnect wiring from switch and mark all wiring for reassembly.
4. Remove switch by depressing spring clips on sides of switch. Push switch out.
5. Reassemble in reverse order and check system operation.

#### MOTOR, BURNER BLOWER – REPLACEMENT

1. Shut off power at main breaker.
2. Remove control box cover and front control box cover.  
Disconnect wiring from motor. Mark all wiring for reassembly.
3. Remove three mounting screws and remove burner blower motor assembly.
4. Reassemble in reverse order and check system operation. Verify Air Mixture Disc is set to  $0.75" \pm 3/16$  (24 – 14mm).

#### TRANSFORMER, BURNER/CONTROL – REPLACEMENT

1. Shut off power at main breaker.
2. Remove control box cover.
3. Disconnect wiring from burner/control transformer and mark all wiring for reassembly.
4. Remove two mounting screws and remove burner/control transformer.
5. Reassemble in reverse order and check system operation.

#### BURNER CONTROL – REPLACEMENT

1. Shut off power at main breaker.
2. Remove control box cover
3. Disconnect wiring from burner control and mark all wiring for reassembly.
4. Remove mounting screws and remove burner control.
5. Reassemble in reverse order and check system operation.

## AIR PRESSURE SWITCH, MAIN FAN MOTOR – REPLACEMENT

1. Shut off power at main breaker.
2. Remove control box cover.
3. Remove cover from air pressure switch. Disconnect wiring from air pressure switch and mark all wiring for reassembly.
4. Remove air switch tube from air pressure switch. Note location of air switch tube, tube must be connected to the "HIGH" port of the air pressure switch.
5. Remove mounting screws and remove air pressure switch.
6. Reassemble in reverse order. Adjust air pressure switch for proper operation (see below) and check system operation.

## AIR PRESSURE SWITCH, MAIN FAN MOTOR – ADJUSTMENT

1. Start the oven. After the burner ignites, turn the air pressure switch adjustment screw Clockwise until the burner shuts off.
2. Turn the adjustment screw Counterclockwise until the burner ignites, plus one full turn.
3. Seal adjustment screw with nail polish.
4. Replace cover on air pressure switch.

## AIR PRESSURE SWITCH, BURNER MOTOR – REPLACEMENT

1. Remove control panel top.
2. Disconnect wires from switch making note of wire number and location for reinstallation.
3. Remove air tube from switch assembly.
4. Remove switch from wire hangar.
5. Install new switch in reverse order, make sure air tube is not blocked or misaligned. Adjust as needed.

## AIR PRESSURE SWITCH, BURNER MOTOR – ADJUSTMENT

To adjust the air pressure switch, remove snap-on cover on the side of the switch to expose adjusting screw. To increase sensitivity, turn screw counter clockwise; to decrease sensitivity, turn screw clockwise. Check for proper line voltage switching from N.C. to N.O. as the air pressure switch closes.

## THERMOCOUPLE – REPLACEMENT

1. Shut off power at main breaker.
2. Remove control box cover.
3. Disconnect thermocouple from oven control. Note wire colors for reassembly.
4. Remove oven back assy. Remove thermocouple from mounting flange in blower housing. Remove thermocouple from oven.
5. Reassemble in reverse order and check system operation.

## THERMOSTAT, HI-LIMIT – REPLACEMENT

1. Shut off power at main breaker.
2. Remove control box cover.
3. Disconnect all wiring from hi-limit thermostat and mark all wiring for reassembly.
4. Remove oven back assy. Remove capillary tube from mounting bracket.
5. Remove mounting nut and remove hi-limit thermostat from oven.
6. Reassemble in reverse order and check system operation.
7. NOTE: Depress reset button to insure thermostat is set for operation.

## TEMPERATURE REGULATION VALVE – REPLACEMENT

1. Shut off power at main breaker.
2. Shut off the gas supply to the oven and disconnect the flexible gas hose from the oven.
3. Remove control box cover.
4. Disconnect all wiring from the temperature regulation valve, modulating gas valve and the main gas valve. Mark all wiring for reassembly.

5. Remove pilot tube from gas valve. Disconnect pipe union at the burner and at the inlet side of the main gas valve. Loosen pipe clamp and remove valves and piping assembly.
6. Remove piping from old valve and reassemble in reverse order.
7. Check all gas line fittings for leaks and check system operation.

#### GAS VALVE – REPLACEMENT

1. Shut off power at main breaker.
2. Shut off the gas supply to the oven and disconnect the flexible gas hose from the oven.
3. Remove control box cover.
4. Disconnect all wiring from the temperature regulation valve, modulating gas valve and the main gas valve. Mark all wiring for reassembly.
5. Remove pilot tube from gas valve. Disconnect pipe unions at the burner and at the inlet side of the main gas valve. Loosen pipe clamp and remove valves and piping assembly.
6. Remove piping from old valve and reassemble in reverse order.
7. Check all gas line fittings for leaks and adjust manifold pressure on gas valve. Refer to the specification plate on the oven for proper gas manifold pressure. Check system operation.

#### MODULATING GAS VALVE – REPLACEMENT

1. Shut off power at main breaker.
2. Shut off the gas supply to the oven and disconnect the flexible gas hose from the oven.
3. Remove control box cover.
4. Disconnect all wiring from the temperature regulation valve, modulating gas valve and the main gas valve. Mark all wiring for reassembly.
5. Remove pilot tube from gas valve. Disconnect pipe unions at the burner and at the inlet side of the main gas valve. Loosen pipe clamp and remove valves and piping assembly.
6. Remove piping from old valve and reassemble in reverse order.
7. Check all gas line fittings for leaks and adjust manifold pressure on gas valve. Refer to the specification plate on the oven for proper gas manifold pressure. Check system operation.

#### MAIN BURNER ORIFICE – REPLACEMENT

1. Shut off power at main breaker.
2. Shut off the gas supply to the oven and disconnect the flexible gas hose from the oven.
3. Remove control box cover and control box front cover.
4. Remove pilot tube from gas valve. Disconnect pipe union at burner, loosen pipe union at inlet to gas valve, loosen pipe clamp and move piping away from burner.
5. Remove two mounting nuts from burner flange and remove burner flange.
6. Remove main burner orifice from the burner flange.
7. Reassemble in reverse order.
8. Check all gas line fittings for leaks and check system operation.

#### PILOT ORIFICE – REPLACEMENT

1. Shut off power at main breaker.
2. Shut off the gas supply to the oven and disconnect the flexible gas hose from the oven.
3. Remove control box cover and control box front cover.
4. Remove pilot tube from gas valve. Disconnect pipe union at burner and at inlet to main gas valve. Loosen pipe clamp and move piping away from burner.
5. Disconnect wiring from burner and mark wiring for reassembly.
6. Remove four screws from burner end plate and remove burner assembly from burner housing.
7. Remove pilot tube from igniter assembly and remove pilot orifice.
8. Reassemble in reverse order. Check all gas line fittings for leaks. Check system operation.

#### SPARK IGNITER – REPLACEMENT

1. Shut off power at main breaker.
2. Shut off the gas supply to the oven and disconnect the flexible gas hose from the oven.
3. Remove control box cover and control box front cover.

4. Remove pilot tube from gas valve. Disconnect pipe union at burner and at inlet to main gas valve. Loosen pipe clamp and move piping away from burner.
5. Disconnect wiring from burner and mark wiring for reassembly.
6. Remove four screws from burner end plate and remove burner assembly from burner housing.
7. Remove pilot tube, pilot shield and pilot orifice from spark igniter and remove spark igniter.
8. Reassemble in reverse order and check system operation.

#### CONVEYOR MOTOR – REPLACEMENT

1. Shut off power at main breaker.
2. Remove control box cover and front control box cover.
3. Disconnect wiring from the conveyor motor assembly and mark all wiring for reassembly.
4. Remove four screws and remove conveyor motor assembly.
5. Reassemble in reverse order and check system operation.

#### CAPACITOR, CONVEYOR MOTOR – REPLACEMENT

1. Shut off power at main breaker.
2. Remove control box cover.
3. Discharge capacitor. Remove mounting screw and replace capacitor.
4. Reassemble in reverse order and check system operation.

#### REVERSING SWITCH – REPLACEMENT

1. Shut off power at main breaker.
2. Remove control box cover. Remove reversing switch cover.
3. Disconnect wiring from reversing switch and mark all wiring for reassembly.
4. Remove mounting nut from reversing switch and remove reversing switch.
5. Reassemble in reverse order and check system operation.

#### OVEN CONTROL – REPLACEMENT

1. Shut off power at main breaker.
2. Remove control box cover.
3. Remove all wiring connections from the oven control and mark all wires for reassembly.
4. Remove oven control by pulling control from the mounting pins. Remove control from oven.
5. Reassemble in reverse order and set the new control for the proper operating mode. See below for set-up procedure:

#### OVEN CONTROL - PROGRAMMING

NOTES: All bake times should be within 10 seconds of set bake time, cavity temperature should be calibrated to within 5° of set temperature. For temperature calibration, allow oven temperature to stabilize for, at minimum, 30 minutes. Before checking conveyor speed, allow conveyor to run for 10 minutes.

1. **BEFORE APPLYING POWER TO OVEN, ENSURE PROPER VOLTAGE JUMPER SETTING FOR 120V or 240V, AND THAT THE 50HZ / 60HZ JUMPER SETTING IS CORRECT. JUMPERS ARE LOCATED ON CONVEYOR CONTROL BOARDS.**

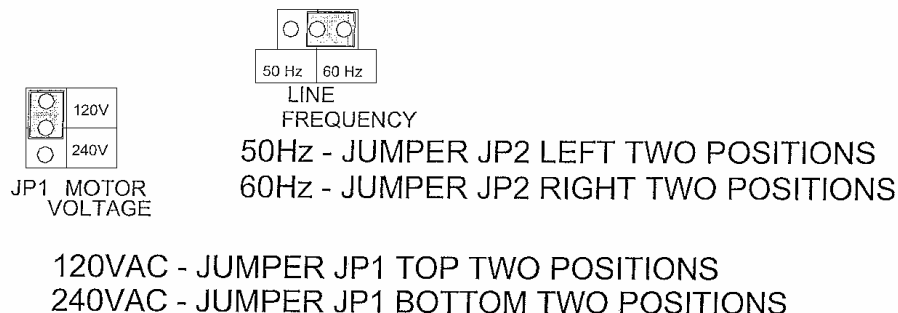

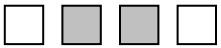
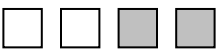
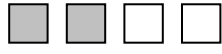
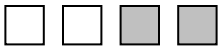
2. To initialize a new control, hold the two center buttons in, then turn unit on.   
Release buttons.
- Select the correct oven model number (e.g. 3240, 3262, or 3270) by toggling the UP or DOWN buttons. When correct model # is selected, press the TEMP button to store.
  - Select the proper belt configuration for this oven by toggling the UP or DOWN buttons. Press the TEMP button to store.
  - Allow control sufficient time to update programming. Shut off main fan switch. Initialization of control is now complete.
3. Set digital control for proper temperature scale – F or C 
- Press and hold the 2 RH buttons to enter Sub-Level program. A prompt will be displayed “**Technicians Only.**” After a couple of seconds a second prompt will say “**Please Release Buttons.**” After releasing the buttons, quickly press the **TIME** button and the **UP** button to enter the program. After **Sub Program Menu** is displayed, press and release the TEMP button. Pressing the UP or DOWN buttons will toggle choices between F and C. After desired scale is selected, allow control to go into normal run mode.
  - Press and hold the 2 RH buttons to enter Sub-Level program. A prompt will be displayed “**Technicians Only.**” After a couple of seconds a second prompt will say “**Please Release Buttons.**” After releasing the buttons, quickly press the **TIME** button and the **UP** button to enter the program. After **Sub Program Menu** is displayed, press temp. button in steps until BANDWIDTH appears. Adjust with the UP and DOWN buttons to a BANDWIDTH setting of 6. Press the TEMP button in steps until THE CUTOUT VOLTAGE appears. With the UP and DOWN buttons, adjust THE CUTOUT VOLTAGE to 3.0. Press the TEMP button in steps until THE CUT IN VOLTAGE appears. With the UP and DOWN buttons, adjust THE CUT IN VOLTAGE to 4.5.
4. Set bake time and oven temperature – Set Point Menu 
- Press and hold the 2 LH buttons to enter Set Point program. Once in Set Point program, press TEMP button and adjust temperature using up or down arrows. Press TIME button while still in Set Point program and adjust time using the UP or DOWN buttons. Pressing TIME or TEMP button will show the respective setting. Once desired settings are programmed, allow control to go into normal running mode.
  - While in this mode, continue to press the TIME button to toggle between different conveyors.
5. Adjust temperature offset – Sub Program Menu 
- Follow the instructions in Step 3 to enter the Sub-level program. After Sub Program Menu is displayed, pressing the TEMP button will access the following temperature features: SCALE (F or C), HI TEMP, LOW TEMP, OFFSET (+ or -), MANUFACTURE MODE (Inactive or Active).  
    - **DO NOT change SCALE after it has been set in step 3A or settings will reset to default values.**
  - To adjust the temperature offset, access the OFFSET display in the Sub Program Menu. If cavity temperature is above the set temperature, decrease (down button) the offset value. If cavity temperature is below the set temperature, increase (up button) the offset value. The amount of offset needed should be the difference between the cavity temperature and the set temperature. Allow oven to reach set temperature and verify cavity temperature. Readjust offset as necessary.
  - HI TEMP and LOW TEMP are not normally changed unless requested by the customer. Accessing these displays and pressing the UP or DOWN buttons will change each indicated setting accordingly.
  - MANUFACTURE MODE is not normally used, therefore, this feature should be set to “clear.”
  - While in the Sub Program Menu, pressing the TIME button will access the time features: HI TIME and LOW TIME. These are not normally changed unless requested by the customer. Accessing these displays and pressing the UP or DOWN buttons will change each indicated setting accordingly.

6. Each conveyor motor will have a unique address on every Motor Controller PCB.  
 Top Belt or Top Front Belt – Dip Switch 1 will be ON, 2,3,and 4 are OFF.  
 Top Back Belt – Dip Switch 2 will be ON and 1, 3 and 4 are OFF.  
 Bottom Belt or Bottom Front Belt – Dip Switch 3 will be ON and 1,2 and 4 are OFF.  
 Bottom Back Belt – Dip Switch 4 will be ON and 1,2 and 3 are OFF.

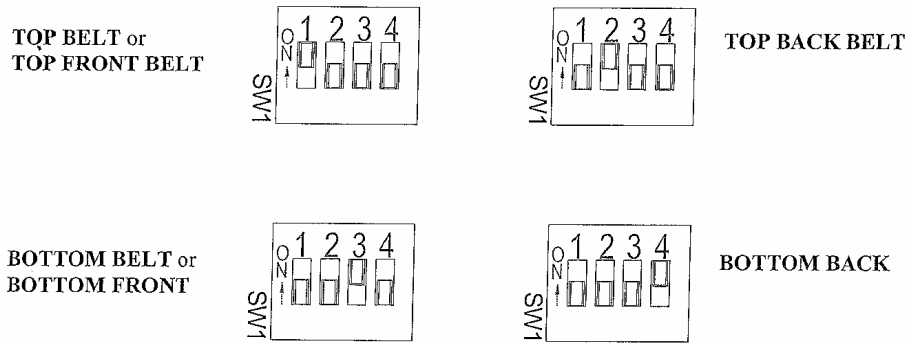

#### CONVEYOR CONTROL – REPLACEMENT

1. Shut off power at main breaker.
2. Remove control box cover.
3. Remove wiring from appropriate conveyor control and mark all wiring for reassembly.
4. Remove conveyor control by pulling control from the mounting pins. Remove control from oven.
5. Reassemble in reverse order and set the new control for the proper operating mode. See: OVEN CONTROL – PROGRAMMING,
6. Test system for proper operation.

## IMPINGER X2 OVENS – GENERAL VIEW

LETTER	PART NUMBER	DESCRIPTION
A	9004984	Finger housing, bottom (3240), #5 left (3262, 3270)
B	9004984	Finger housing, bottom (3240), #6 right (3262, 3270)
C	9004983	Finger housing, middle (3240), #3 left (3262, 3270)
D	9004983	Finger housing, middle (3240), #4 right (3262, 3270)
E	9004985	Finger housing, top, (3240), #1 left (3262, 3270)
F	9004985	Finger housing, top, (3240), #2 right (3262, 3270)
G	7007757	Finger cover, top
H	7007168	Finger cover, middle
I	7007168	Finger cover bottom
J	1111302010	Air return, middle, upper model 3262, 3270
K	1001303010	Air return, lower model 3262
	2001303020	Air return, lower model 3270
L	9004547	Finger guide assy. model 3240, 3262, 3270
M	9004547	Finger guide, rear
N	SEE PAGE 31 FOR DOOR OPTIONS	
O	2805112	Nameplate, Impinger X2
P	SEE PAGE 31 FOR DOOR OPTIONS	
Q	100302900	Caster, 5"
	100303900	Caster, 5" w/brake
R	300202036	Bottom finger support, 3240
	100202036	Bottom finger support, 3262
	200202036	Bottom finger support, 3270
S	9004447	Center finger support, 3240
	9004443	Center finger support, 3262
	9004417	Center finger support, 3270
T	9004448	Top finger support, 3240
	9004434	Top finger support, 3262
	9004418	Top finger support, 3270
U	100537902	Door latch assy.
V	9409	Oven base, high – 3240
	9414	Oven base, low –3240
	9402	Oven base, high – 3262
	9411	Oven base, low – 3262
	9404	Oven base, high – 3270
	9412	Oven base, low – 3270
W	108003-1EP	Hinge plate, left
	108003-2EP	Hinge plate, right
X	9004439	Center air return, upper – 3262
	9004436	Center air return, upper – 3270
Y	9004440	Center air return, middle – 3262
	9004437	Center air return, middle – 3270
Z	9004441	Center air return, lower – 3262
	9004438	Center air return, lower – 3270



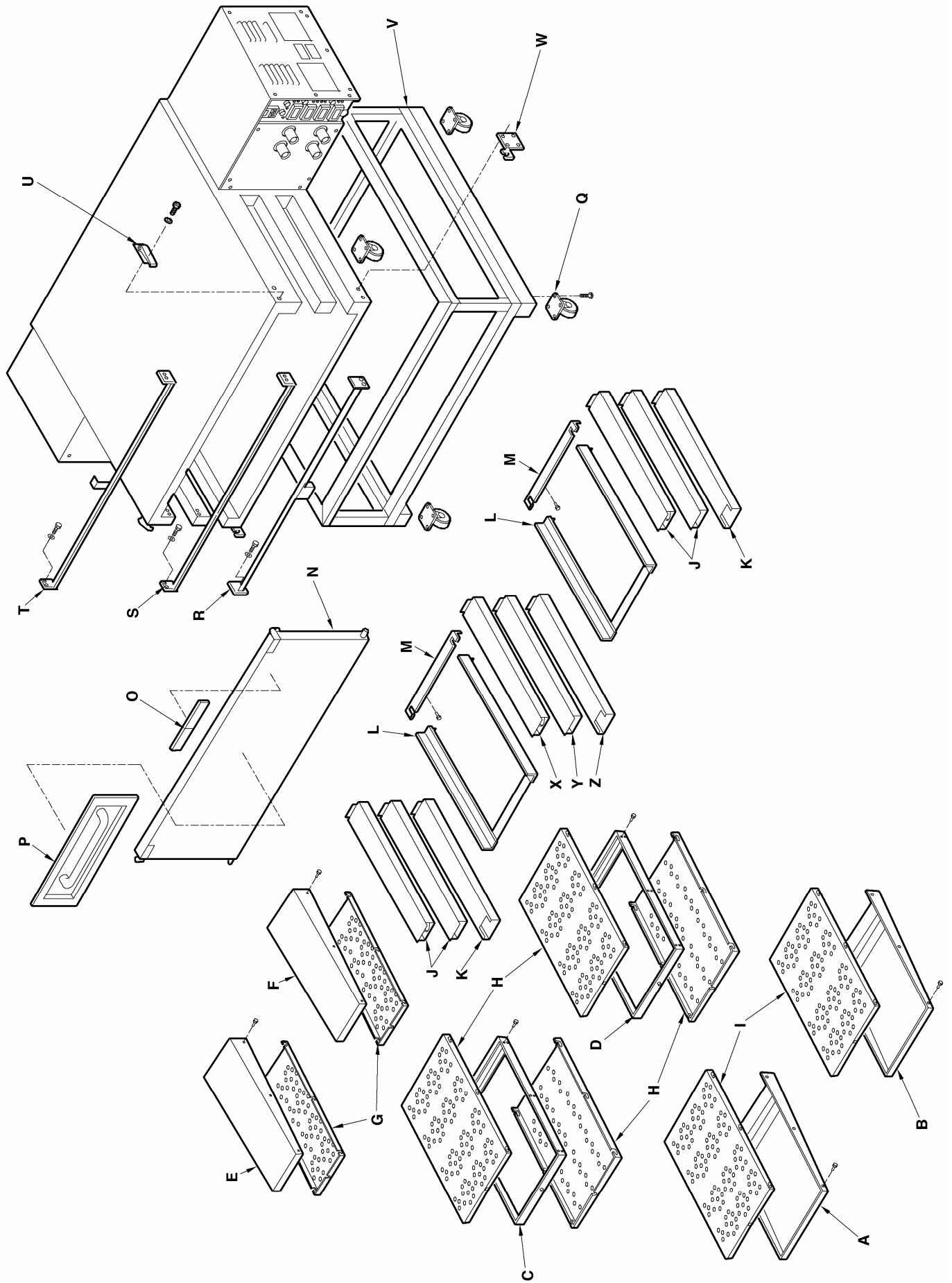

# IMPINGER X2 OVENS

## OVEN CAVITY

LETTER	PART NUMBER	DESCRIPTION
A	9004435	Guard, shaft – 3262
	9004419	Guard, shaft – 3270
B	4071215	Housing, blower
C	100601417	Air return plate, right – 3240, 3262
	200601417	Air return plate, right – 3270
D	100601417	Air return plate, left – 3240, 3262
	200601417	Air return plate, left – 3270
E	100601394	Air dam, upper
F	100110224	Close-off, upper plenum
G	100102601	Support, oven cavity
H	100106000	Plate, connector
I	300601280	Extension tube, burner – 3240
	100601280	Extension tube, burner – 3262
	200601280	Extension tube, burner – 3270
J	300601328	Shaft, blower wheel assy. – 3240
	100601328	Shaft, blower wheel assy. – 3262
	200601328	Shaft, blower wheel assy. – 3270
K	3001401011	Oven back – 3240
	1001401011	Oven back – 3262
	2001401011	Oven back – 3270
L	100601334 / 100601336	Burner heat shield, outer, inner
M	100601324	Burner opening cover
N	390048	Heat slinger – 3240
	390047	Heat slinger – 3262, 3270
O	390063	Bearing, idler
P	9004431	Top cover, idler end
Q	100120224	Cover, idler end
R	100110204	Flange, thermocouple mount
S	7007374	Guard, center air return – 3262
	7007375	Guard, center air return - 3270

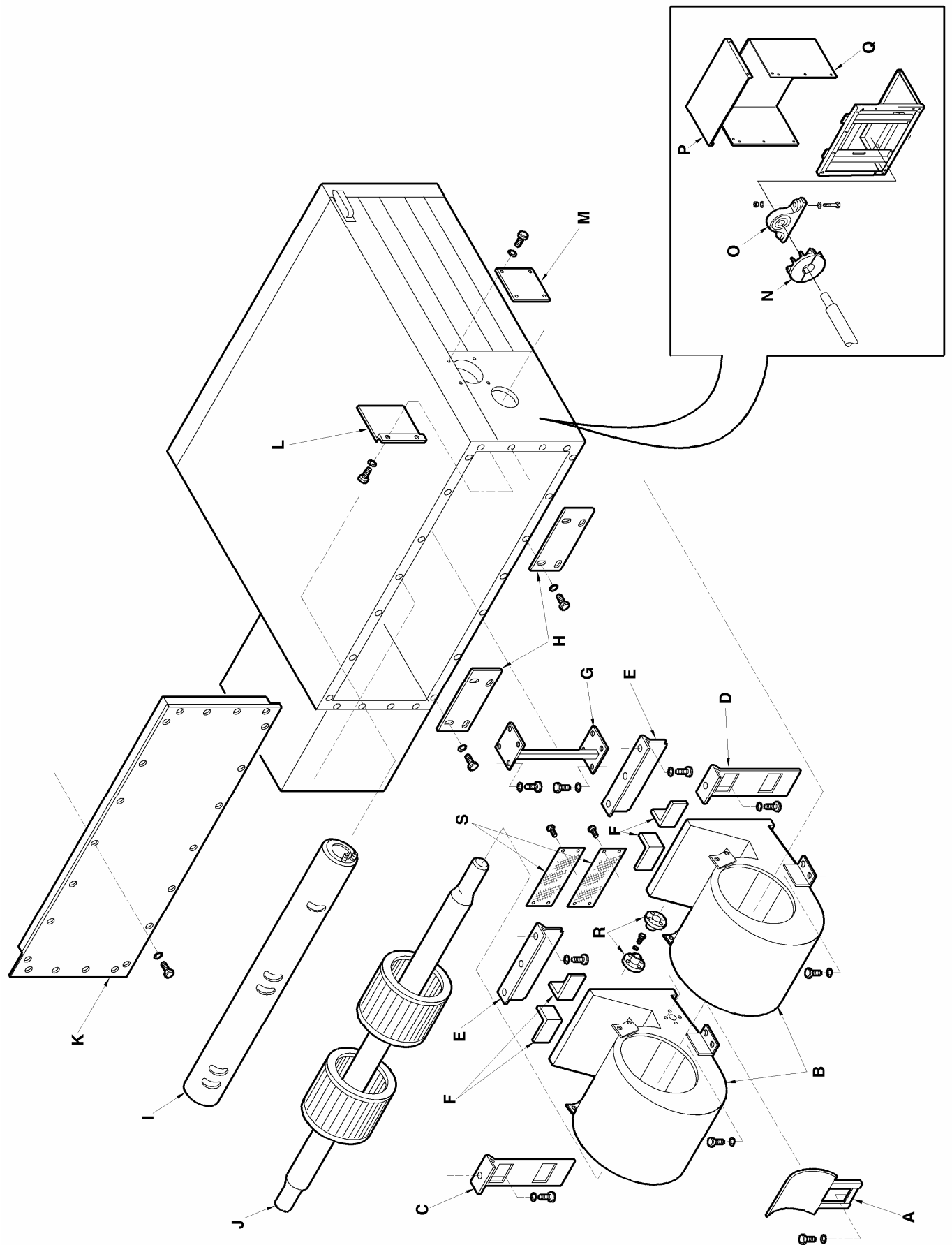

## IMPINGER X2 OVENS - CONTROL BOX

LETTER	PART NUMBER	DESCRIPTION
A	390080	Drive End, Rear
B	390081	Drive End, Lid
C	390082	Cover, Switch
D	390092	Fuse – 1A
	369013	Fuse – 3A (50 Hz Model Only)
E	390079	Fuse holder
	370342	Fuse holder (50 Hz Model Only)
F	370359	Reversing Switch
G	390100	Contactor
H	370466	Time Delay Module, 230 Volt
I	390083	Terminal Block 5 Pole (60 Hz Model Only)
J	369368	Thermostat, Hi-Limit
K	369125	Terminal Block
L	390084	Front Facia, Control Box
M	390085	Conveyor Motor, Models 3262, 3270
	390086	Conveyor Motor, Model 3240 (60 Hz Model Only)
N	508120EP	Lovejoy Coupling
O	390101	Front Cover – 2 oven
	390102	Front Cover – 2TS oven (split belt top)
	390103	Front Cover – 2SB oven (split belt bottom)
	390087	Front Cover – 2SS oven (split belt top & bottom)
P	390088	Transformer 230 Volts AC
Q	369432	On-Off Switch – 60 Hz (60 Hz Model Only)
	370541	On-Off Switch – 50 Hz (50 Hz Model Only)
R	390089	Digital Control Board
S	370360	Capacitor, 230V Digital
T	390090	Control, Conveyor
U	501070EP	Air Pressure Switch
V (Note: See page 30)	508202EP	Fan Belt (with BK 45 Pulley)
	390128	Fan Belt
X	390059	Pulley, BK 45
Y	390078	Motor, main fan, 3HP, 1 Phase (60 Hz Model Only)
	390096	Motor, main fan, 3HP, 3 Phase (60 Hz Model Only)
	390135	Motor, main fan, 3HP, 1 Phase (50 Hz Model Only)
	390136	Motor, main fan, 3HP, 3 Phase (50 Hz Model Only)
Z	369575	Air Pressure Switch
AA	369393	Ignition Control (60 Hz Model Only)
	370396	Ignition Control (50 Hz Model Only)
AB	370364	Ground Lug
AC	390129	J-Box Cover (50 Hz Model Only)
AD	370178	Junction Box (50 Hz Model Only)
AE	369469	Terminal Bracket Wldmt (50 Hz Model Only)
AF	369376	Terminal Block 3 Pole (50 Hz Model Only)
AG	369698	Cover 4" (50 Hz Model Only)
AH	390138	Control Panel Assembly
Not Shown	390095	Thermocouple, type "K"
Not Shown	369579	Alarm (50 Hz Model Only)
Not Shown	390130	Motor Guard Shield (50 Hz Model Only)

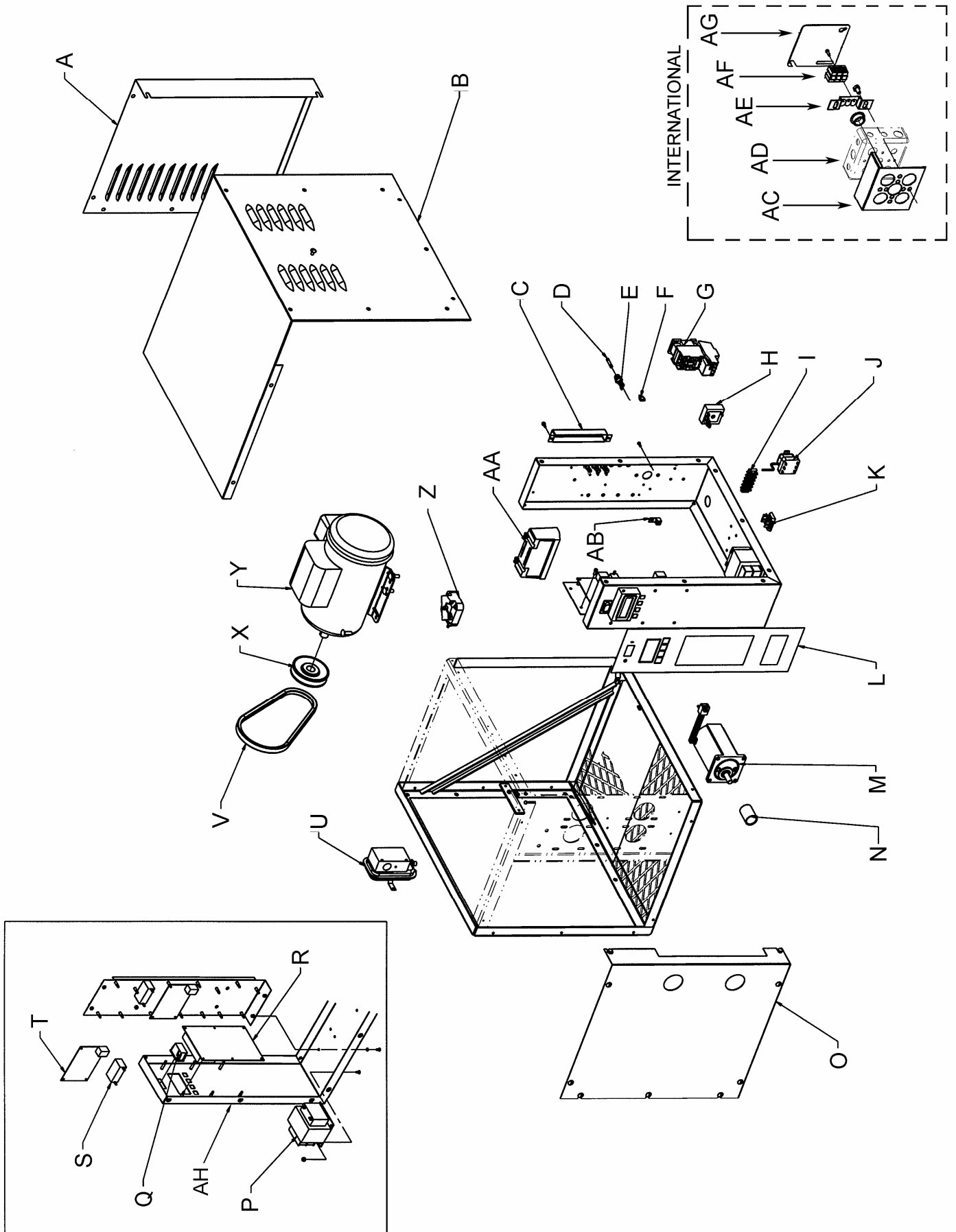

# !! CAUTION !!

Please note that a model number change associated with the Baldor Main Fan Motor has been instituted. This change in motor model number also requires a change in the type of fan belt being used. Therefore, when replacing a fan belt it is important to note which type of motor is being used.

Use the following fan belt ...	when using this main fan motor...
Gates 6929 (V-Belt, 21/32" x 29") Lincoln Part # 390128	Motor, main fan, 3HP, 1 Phase (60 Hz Model Only) Vendor-35V087T356G1
	Motor, main fan, 3HP, 3 Phase (60 Hz Model Only) Vendor-35V426T676G1
	Motor, main fan, 3HP, 1 Phase (50 Hz Model Only) Vendor-35V424Q013G1
	Motor, main fan, 3HP, 3 Phase (50 Hz Model Only) Vendor-35V426Y886G1
Gates 6931 (V-Belt, 21/32" x 31") Lincoln Part # 508202EP	Baldor Motor P/N <b>M3161TA</b> – Lincoln Production #4060274
	Baldor Motor P/N 35S270T356 – Lincoln Production #4060276

Baldor Motors:  
**M3161TA**  
35S270T356

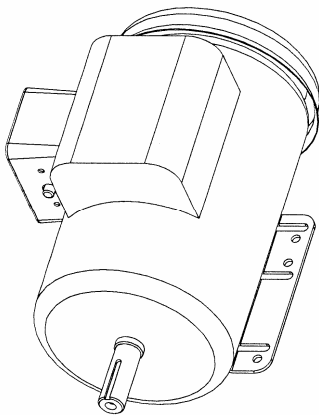

Baldor Motors:  
35V424Q013G1  
35V087T356G1

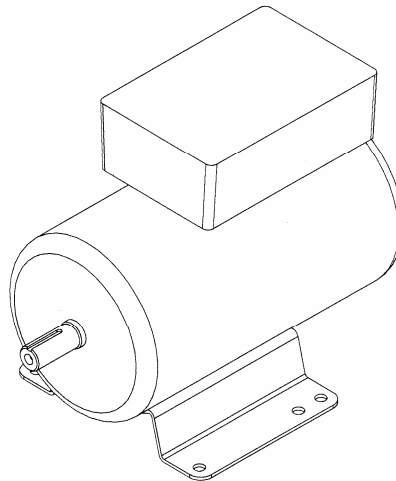

Baldor Motors:  
35V426T676G1  
35V426Y886G1

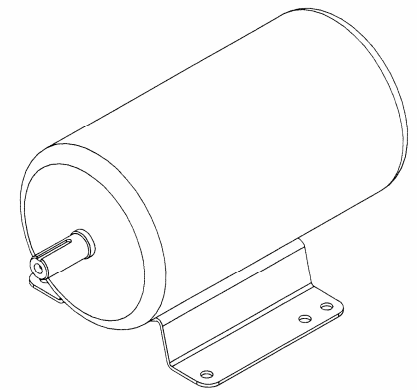

This motor requires the following fan belt:

Lincoln Part # 508202EP  
Dimensions: 21/32" x 31"

This motor requires the following fan belt:

Lincoln Part # 390128  
Dimensions: 21/32" x 29"

This motor requires the following fan belt:

Lincoln Part # 390128  
Dimensions: 21/32" x 29"

## IMPINGER X2 OVENS - DOOR ASSEMBLY

PART NUMBER	DESCRIPTION
390139	Sandwich Door Assembly (Single Handle)
390140	Sandwich Door Assembly (Double Handle)
100804622	Old Style Single Sandwich Door
300801140-1	Door, Solid – Model 3240
100801140-1	Door, Solid – Model 3262
200801140-1	Door, Solid – Model 3270
300801140	Old Style Door, w/ single sandwich door – Model 3240
100801140	Old Style Door, w/ single sandwich door – Model 3262
200801140	Old Style Door, w/ single sandwich door – Model 3270
9005192	New Style Door, w/ double sandwich door – All Models

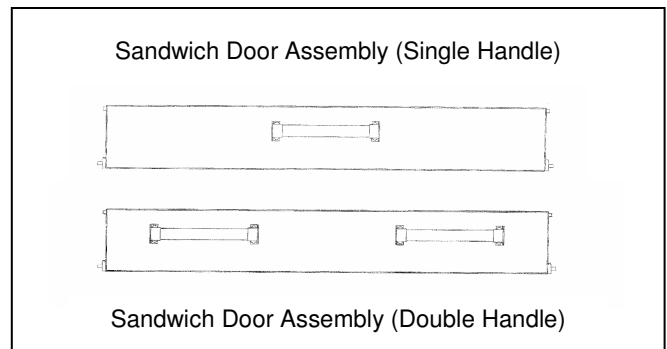
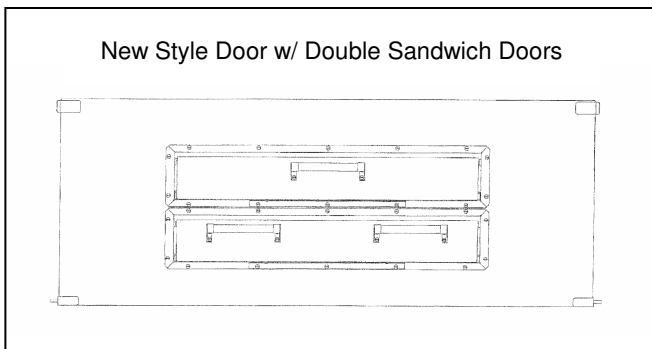
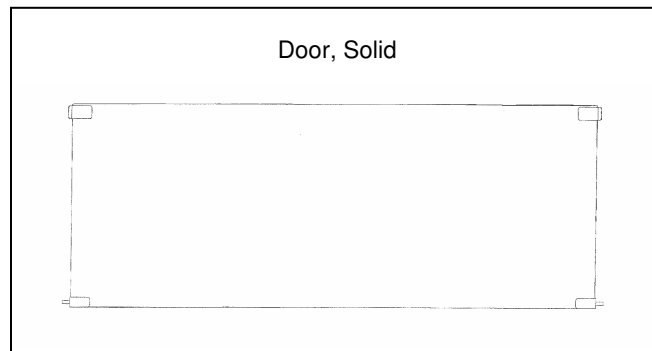
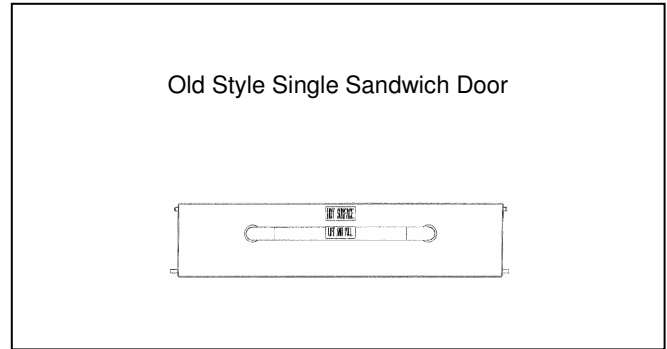
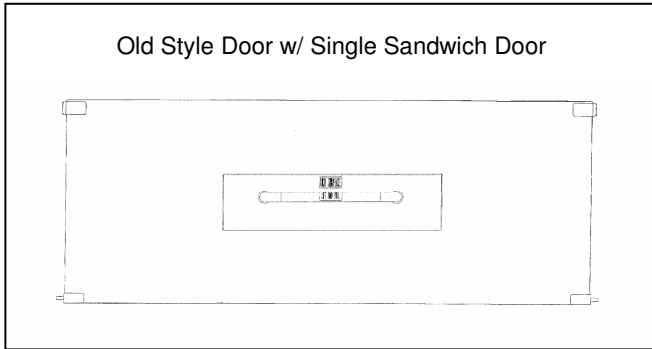

# IMPINGER X2 OVENS

## BURNER/DRIVE END

LETTER	PART NUMBER	DESCRIPTION
A	390104	Flange, burner
B	390048	Heat slinger, 3240
	390047	Heat slinger, 3262, 3270
C	507500EP	Bearing, drive end
D	390097	Motor, burner blower (60 Hz Model Only)
	390076	Motor, Burner Blower (50 Hz Model Only)
E	390105	Valve, Modulation (Nat.)
	390132	Valve, Modulation (L.P.)
G	369142	Flame target (used on 60 Hz model only)
H	501250-1EP	Igniter/sensor assy.
	390134	Igniter/sensor assy. with wire (50 Hz Model Only)
I	390114	Shield, pilot
J	390099	Cable, spark (60 Hz Model Only)
K	390115	Orifice, Pilot, Nat. (60 Hz Model Only)
	369073	Orifice, Pilot, Nat. (50 Hz Model Only)
	390098	Orifice, Pilot, L.P. (60 Hz Model Only)
	390125	Orifice, Pilot, L.P. (50 Hz Model Only)
L	370059	Manifold, Burner (60 Hz Model Only)
	390133	Manifold, Burner (50 Hz Model Only)
M	390111	Temperature Regulation Valve (60 Hz Model Only)
	390127	Temperature Regulation Valve (50 Hz Model Only)
N	390093	Valve, Natural Gas 24V (60 Hz Model Only)
	370405	Valve, Natural Gas (50 Hz Model Only)
	390094	Valve, L.P. Gas 24V (60 Hz Model Only)
	390126	Valve, L.P. Gas (50 Hz Model Only)
O	390116	Orifice, Main Burner, Nat.
	390117	Orifice, Main Burner, L.P.
P	369400	Moveable plate, air shutter
Q	369399	Air shutter



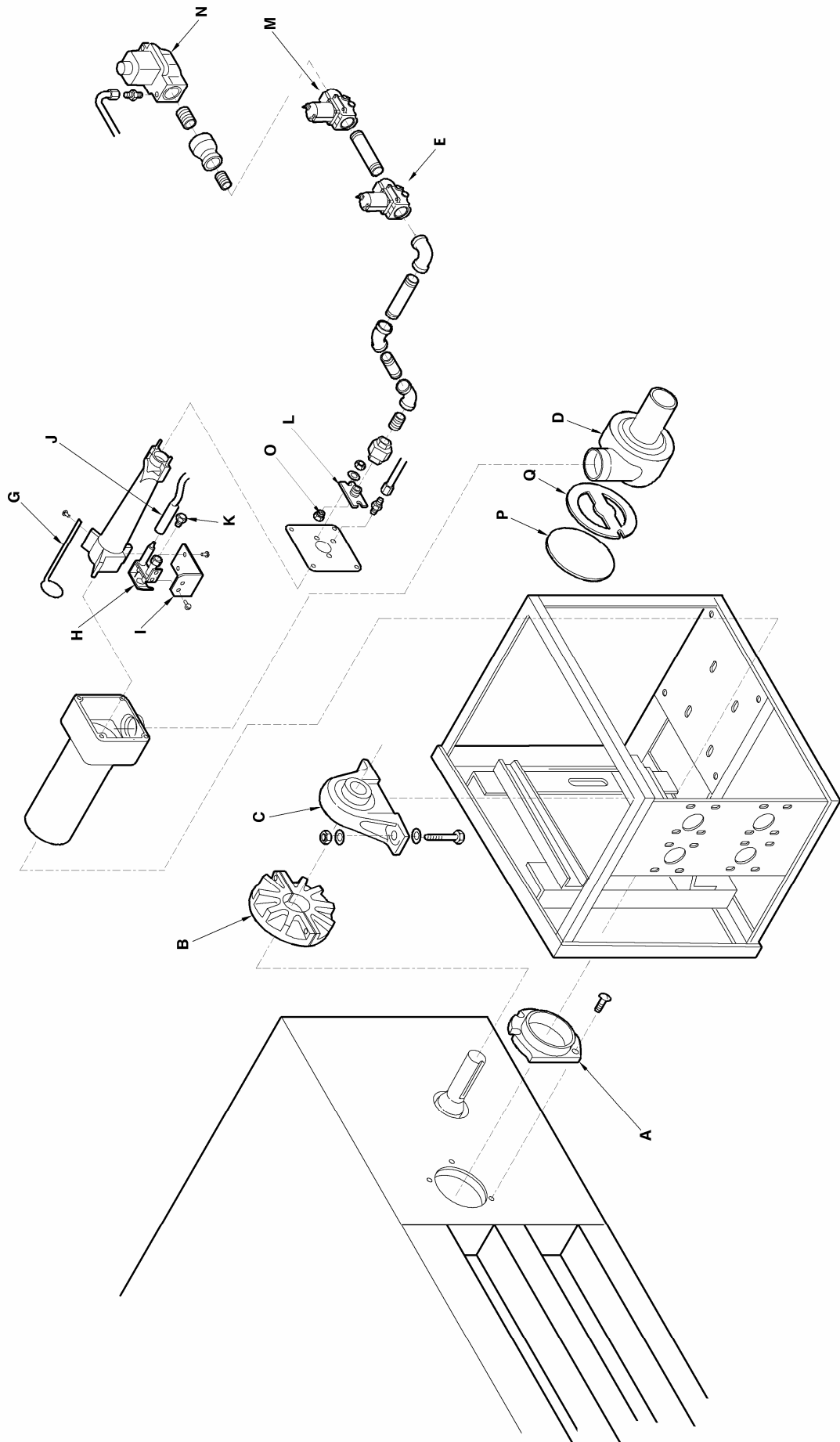

# IMPINGER X2 OVENS

## CONVEYOR, SINGLE

LETTER	PART NUMBER	DESCRIPTION
A	100403103	Shelf, infeed side
	100403101	Shelf, out take side
B	100403107	Pan stop, zero stop
C	10000686	Crumb Tray Left
	10000687	Crumb Tray Right
D	369005	Connecting link
E	100405831	Conveyor belt - complete, 3240
	100405810	Conveyor belt - complete, 3262
	100405830	Conveyor belt - complete, 3270
	405830-1EP	Conveyor belt –1ft. section
F	390051	Bushing assembly, single belt
G	100404710	Shaft, idle end
H	406000EP	Roller, smooth
I	405900EP	Roller, notched
J	300403331	Frame assembly, upper conveyor, 3240
	100403361	Frame assembly, upper conveyor, 3262
	200403390	Frame assembly, upper conveyor, 3270
	300403330	Frame assembly, lower conveyor, 3240
	100403360	Frame assembly, lower conveyor, 3262
	200403380	Frame assembly, lower conveyor, 3270
K	508103EP	Coupling half
L	100404810	Shaft, drive end

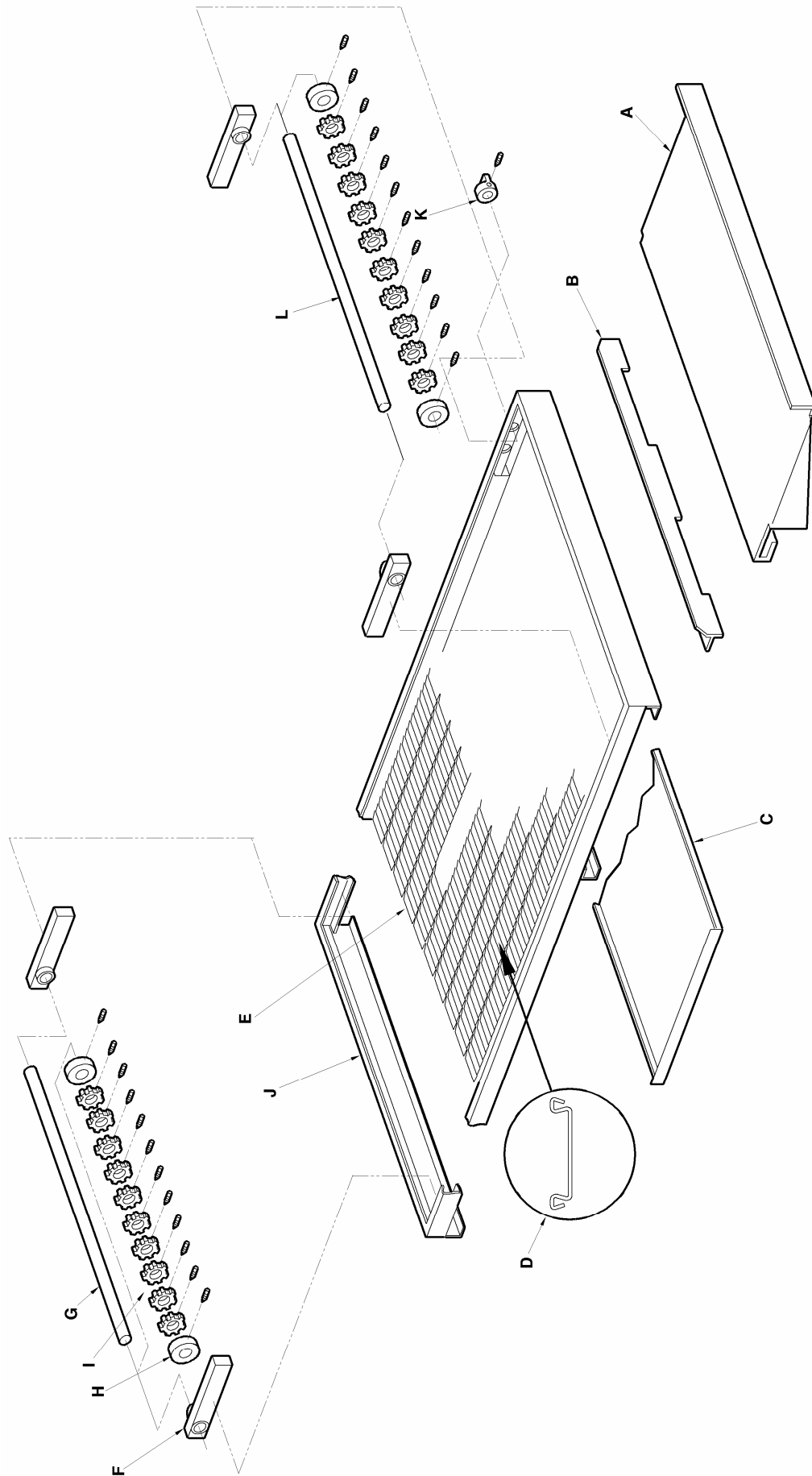

# IMPINGER X2 OVENS

## CONVEYOR, DUAL BELT

LETTER	PART NUMBER	DESCRIPTION
A	100403103	Take off shelf, infeed side
	390120	Take off shelf, out take side
B	390119	Pan stop, zero stop
C	10000686	Crumb Tray Left
	10000687	Crumb Tray Right
D	405849-2EP	Connecting link
E	100405847	Conveyor belt, complete, 3240
	405849EP	Conveyor belt, complete, 3262
	100405844	Conveyor belt, complete, 3270
	405849-1EP	Conveyor belt, 1ft. section
F	390050	Bushing assembly, dual belt
G	100404710	Shaft, idle end
H	406000EP	Roller, smooth
I	405900EP	Roller, notched
J	300403331	Frame assembly, upper conveyor, 3240
	100403361	Frame assembly, upper conveyor, 3262
	200403390	Frame assembly, upper conveyor, 3270
	300403330	Frame assembly, lower conveyor, 3240
	100403360	Frame assembly, lower conveyor, 3262
	200403380	Frame assembly, lower conveyor, 3270
K	508103EP	Coupling half
L	100404810	Shaft, drive

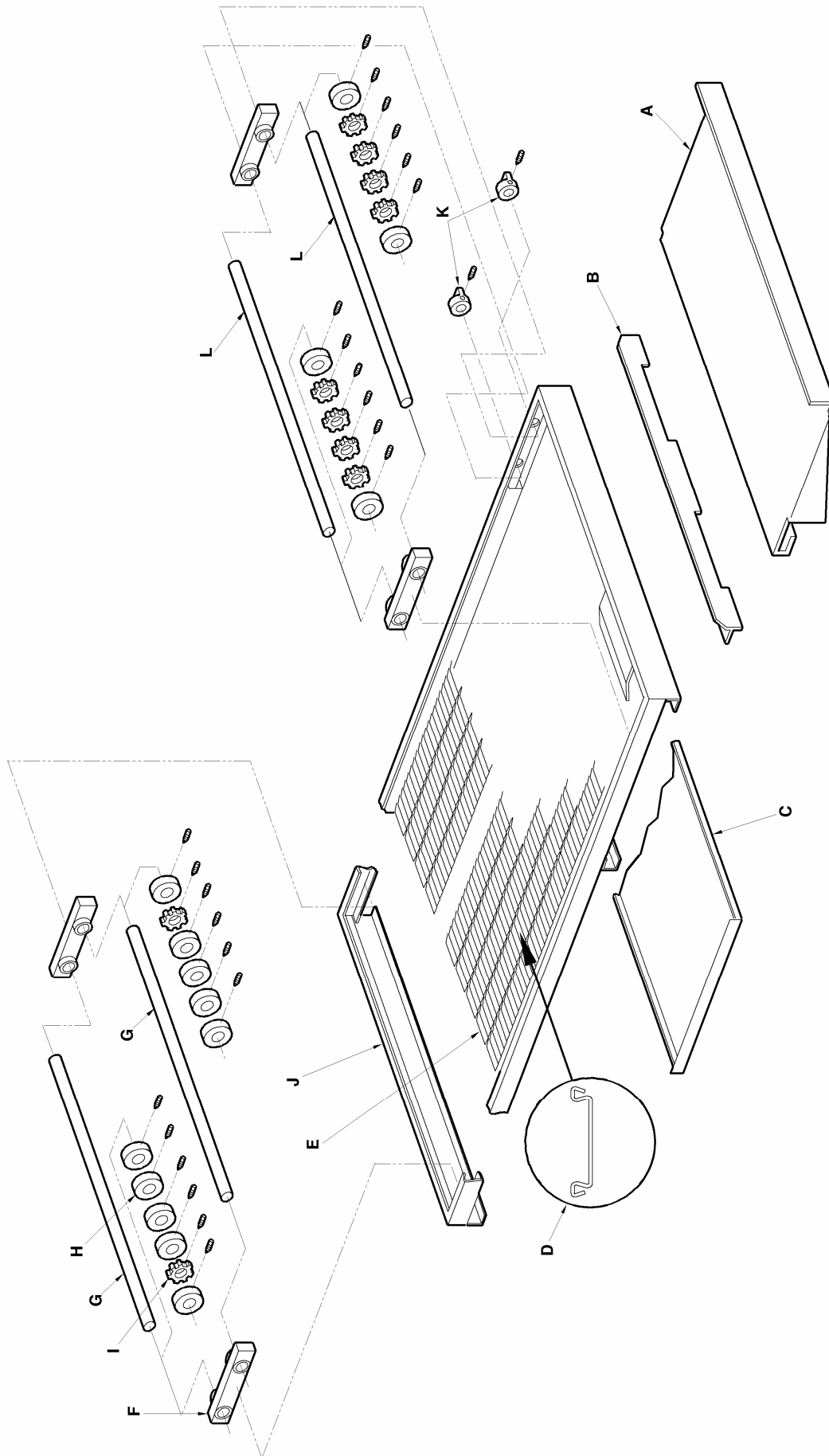

This page intentionally left blank.

This page intentionally left blank.

