

# **MODULAR**

## ***CATERING EQUIPMENT***

**ISTRUZIONI PER L'USO**  
**OPERATING INSTRUCTIONS**  
**MODE D'EMPLOI**  
**BEDIENUNGSANLEITUNG**  
**GBRUIKSAANWIJZING**  
**BRUGERVEJLEDNING**  
**INSTRUCCIONES DE USO**  
**INSTRUCÕES DE UTILIZAÇÃO**  
**ΟΔΗΓΙΕΣ ΛΕΙΤΟΥΡΓΙΑΣ**



Code 252.252.10

**FRONT OPENING GLASS**  
**AND DISH WASHERS**



- |            |           |             |
|------------|-----------|-------------|
| - ECO 4    | - L 45    | - ECO 5     |
| - ECO 41   | - L 451   | - ECO 51    |
| - ECO 42   | - L 452   | - ECO 52    |
| - ECO 43 A | - L 456 A | - ECO 56 A  |
| - ECO 45   |           | - ECO 51 T  |
| - ECO 46   |           | - ECO 52 T  |
| - ECO 47 A |           | - ECO 56 AT |

# INDEX

- 1 INTRODUCTION**
- 2 WARNINGS**
- 3 COMPLIANCE WITH “EEC” DIRECTIVES**
- 4 INSTALLATION DIAGRAMS**
  - 4.1 ECO 4 Installation diagram
  - 4.2 L 45 Installation diagram
  - 4.3 ECO 5 Installation diagram
- 5 WIRING DIAGRAMS**
- 6 IDENTIFICATION MARKING**
- 7 TECHNICAL CHARACTERISTICS**
- 8 INSTRUCTIONS FOR INSTALLERS**
  - 8.1 Preparing for installation
  - 8.2 WARNINGS
  - 8.3 Laws, technical regulations and general rules
  - 8.4 Installation
- 9 CONNECTING THE WATER SUPPLY**
- 10 CONNECTING THE ELECTRICAL SUPPLY**
- 11 EQUIPOTENTIAL CONNECTION**
- 12 ADJUSTMENTS AND CHECKS**
  - 12.1 Rinse aid dispenser
  - 12.2 Loading the detergent
- 13 DISPENSER FOR LIQUID DETERGENT (optional)**
  - 13.1 Start-up
  - 13.2 Operation
  - 13.3 How to regulate the detergent dispenser
  - 13.4 example of how to set the amount of detergent required
- 14 FUNCTIONAL CHECKS**
- 15 USER INSTRUCTIONS**
  - 16 CONTROL AND COMMAND PANELS
  - 17 SETTING IN OPERATION
  - 18 DECALCIFICATION AND REGENERATION OF RESINS
  - 19 DRAINAGE PUMP
  - 20 ADVICE TO USERS
    - 20.1 Periodic maintenance
- 21 SERVICE MANUAL AND ADVICE FOR TROUBLESHOOTING**

## 1 INTRODUCTION

The manufacturing company declines all responsibility for any inaccuracies contained in this handbook due to printing or spelling mistakes.

The manufacturers decline all responsibility if standard safety norms are complied with.

The manufacturers reserves the right to modify their products if necessary without compromising the basic characteristics.

## 2 WARNINGS

The information contained in this manual aims at providing guidelines regarding:

- technical characteristics;
- installation and mounting instructions;
- information on how to train the personnel responsible for the use of the appliances;
- use of appliances;
- maintenance work.

The manual must be considered part of the appliances, and must therefore be kept in a safe place for future reference.

Keep it safely with the machine for technicians and operators.

The manufacturer shall not be held liable for any of the following instances:

- improper use of the appliances;
- improper installation performed without complying with the procedures contained herein;
- faulty electrical power supply;
- serious inadequacies in the prescribed maintenance;
- unauthorised alterations or interventions;
- use of non-standard or non-specific parts;
- failure to comply with the instructions, either partially or fully.

Electrical appliances can be dangerous. Current standards and regulations must be adhered to during installation and use of the appliances.

### **De-activate the appliance in case of damage or malfunctioning.**

For repairs contact a reliable retailer only.

## 2 COMPLIANCE WITH "EEC" DIRECTIVES

**NOTE:** Our products are made in compliance with the essential requirements established by the EEC directives in agreement with the "EEC 73/23 Low Voltage Directive, with the "EEC 89/336 EMC Directive, and according to the EEC Directive no. 23 of 19/02/73, and amended directive no.791 of 18/10/87, our appliances are manufactured according to current Italian and foreign technical standards.

## 4 INSTALLATION DIAGRAMS

### 4.1 ECO 4 Installation diagram (code 255.137.00)

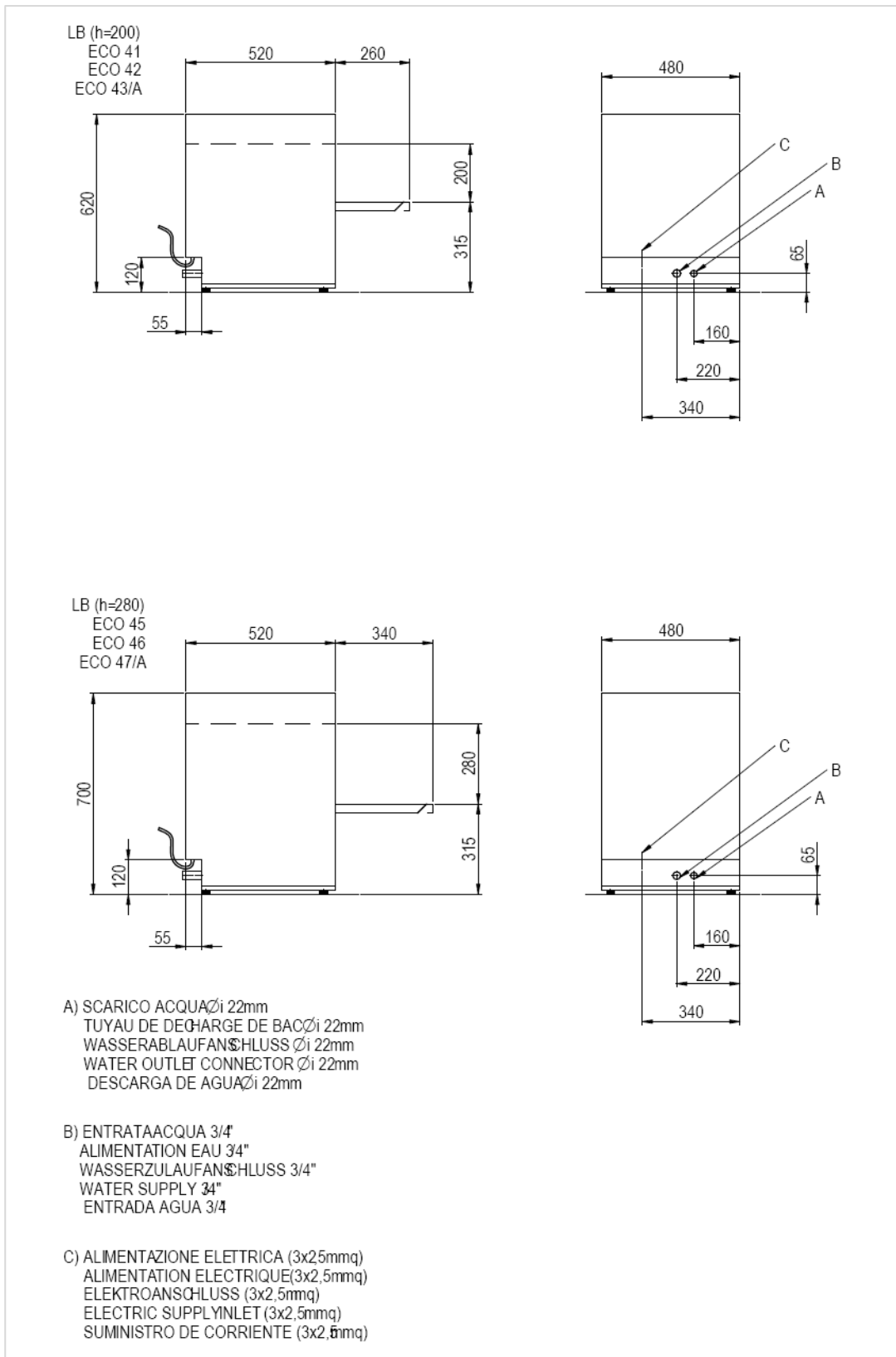

4.2 L 45 Installation diagram (code 255.146.00)

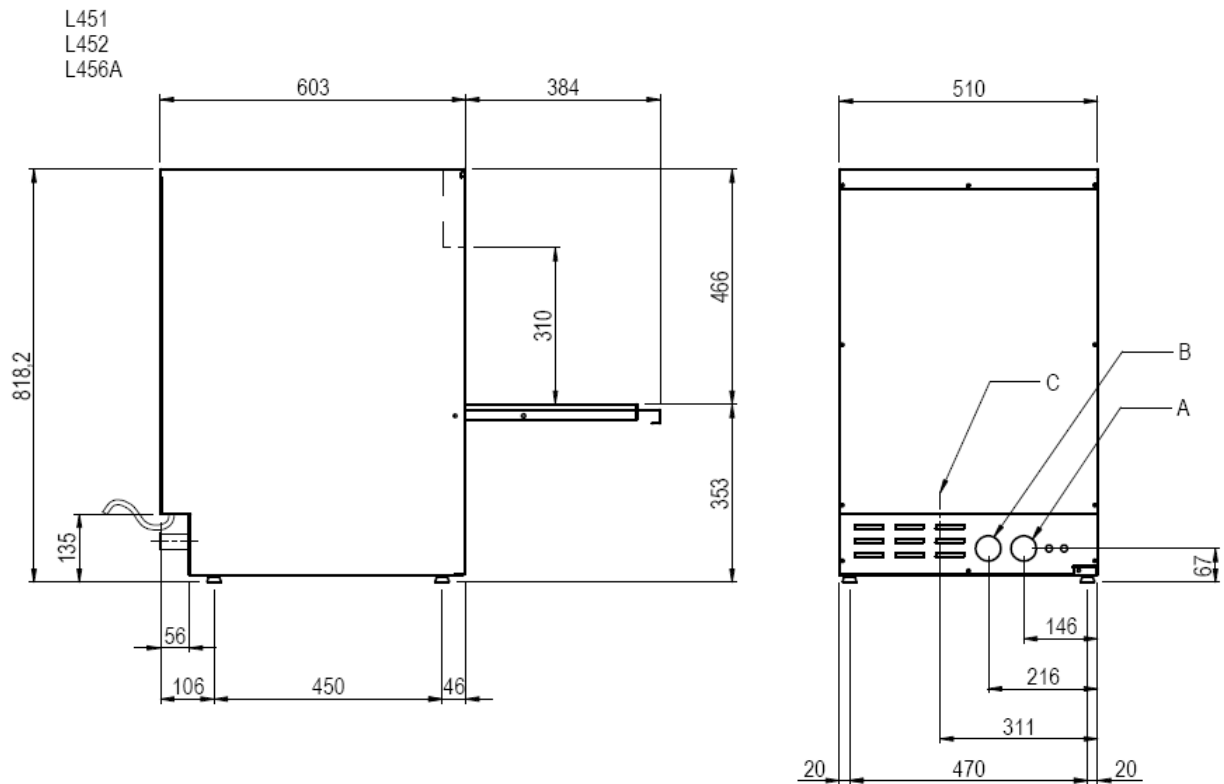

- A) SCARICO ACQUA  $\varnothing$ i 28mm  
 TUYAU DE DECHARGE DE BAC  $\varnothing$ i 28mm  
 WASSERABLAUFANSCHLUSS  $\varnothing$ i 28mm  
 WATER OUTLET CONNECTOR  $\varnothing$ i 28mm  
 DESCARGA DE AGUA  $\varnothing$ i 28mm
- B) ENTRATA ACQUA 3/4"  
 ALIMENTATION EAU 3/4"  
 WASSERZULAUFANSCHLUSS 3/4"  
 WATER SUPPLY 3/4"  
 ENTRADA AGUA 3/4"
- C) ALIMENTAZIONE ELETTRICA (3x2,5mmq)  
 ALIMENTATION ELECTRIQUE (3x2,5mmq)  
 ELEKTROANSCHLUSS (3x2,5mmq)  
 ELECTRIC SUPPLY INLET (3x2,5mmq)  
 SUMINISTRO DE CORRIENTE (3x2,5mmq)

### 4.3 ECO 5 Installation diagram (code 255.146.00)

LS  
 ECO 51 ECO 51T  
 ECO 52 ECO 52T  
 ECO 56/A ECO 56/AT

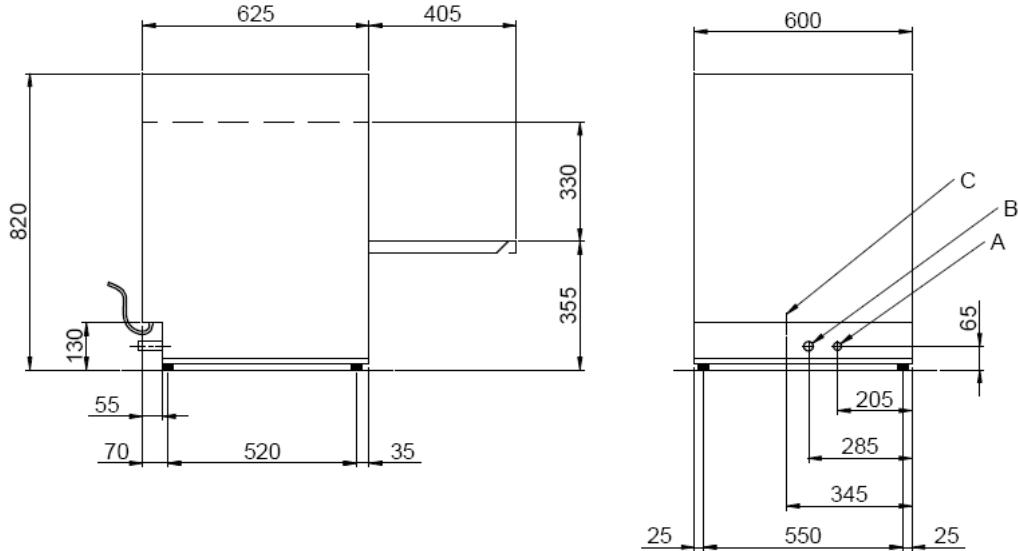

A) SCARICO ACQUA  $\varnothing$ i 31mm  
 TUYAU DE DECHARGE DE BAC  $\varnothing$ i 31mm  
 WASSERABLAUFANSCHLUSS  $\varnothing$ i 31mm  
 WATER OUTLET CONNECTOR  $\varnothing$ i 31mm  
 DESCARGA DE AGUA  $\varnothing$ i 31mm

B) ENTRATA ACQUA 3/4"  
 ALIMENTATION EAU 3/4"  
 WASSERZULAUFANSCHLUSS 3/4"  
 WATER SUPPLY 3/4"  
 ENTRADA AGUA 3/4"

C) ALIMENTAZIONE ELETTRICA (230V-1N 3x2,5mmq)  
 (400V-3N 5x2,5mmq)  
 ALIMENTATION ELECTRIQUE (230V-1N 3x2,5mmq)  
 (400V-3N 5x2,5mmq)  
 ELEKTROANSCHLUSS (230V-1N 3x2,5mmq)  
 (400V-3N 5x2,5mmq)  
 ELECTRIC SUPPLY INLET (230V-1N 3x2,5mmq)  
 (400V-3N 5x2,5mmq)  
 SUMINISTRO DE CORRIENTE (230V-1N 3x2,5mmq)  
 (400V-3N 5x2,5mmq)

## 5 WIRING DIAGRAMS

## 6 IDENTIFICATION MARKING

The appliance is provided with a data plate. In order to identify the appliance, for an adequate after sales service and proper use of this manual refer to "Electrical data – General characteristics".

## 7 TECHNICAL CHARACTERISTICS

ECO 4 GLASS WASHER						
TECHNICAL CHARACTERISTICS	MODELS					
	41	42	43	45	46	47
Standard	S*			S*		
Non-return device*		S*			S*	
Water softener			S*			S*
Dimensions WxDxH ( mm)	480x520x620			480x520x700		
Basket dimensions ( mm)	400x400					
Useable clearance ( mm)	200			280		
Total cycle time (sec)	120					
Production baskets/hour	30					
Tub capacity in lt.	8					
Boiler capacity in lt.	4.5					
Consumption of water per cycle (l)	2.2					
Tub power (kW)	1.2					
Boiler power (kW)	3					
Wash pump power (kW)	0.2					
Pressure increase pump power ( kW)	0.46					
Total power kW	3.2					
Water supply temperature °C	15-50		15-40		15-50	15-40
Water hardness °F	7-12		>15		7-12	>15
Pressure (bar)	2-4		3.4		2-4	3.4
Power voltage	230 V 1					
Frequency	50Hz					
Noise levels ( dBA)	<70					
<b>STANDARD EQUIPMENT</b>						
Supply fitting ¾"G	Yes					
Drain fitting	Yes					
Boiler safety thermostat	Yes					
Rinse aid dispenser	Yes					
Flat mesh basket (n°)	2					
Cutlery basket (n°)	1					
Insert for saucers	1					
<b>ACCESSORIES ON REQUEST</b>						
Round basket	Yes		Yes		Yes	
Detergent dispenser	Yes		Yes		Yes	
Pressure increase pump	Yes		Yes		No	
Drain pump	Yes		Yes		Yes	
Cold rinse	Yes		Yes		Yes	
<b>NRD =non-return device S= standard</b>						

<b>L45 DISHWASHER</b>			
<b>TECHNICAL CHARACTERISTICS</b>	<b>MODELS</b>		
	<b>451</b>	<b>452</b>	<b>456</b>
Standard	<b>S*</b>	/	/
Non-return device*	/	<b>S*</b>	/
Water softener	/	/	<b>S*</b>
Dimensions LxDxH ( mm)	510x603x818		
Basket dimensions ( mm)	450x450		
Useable clearance ( mm)	310		
Total cycle time (sec)	150		
Production baskets/hour	24		
Tub capacity in lt.	18		
Boiler capacity in lt.	6.9		
Consumption of water per cycle (l)	2.6		
Tub power (kW)	1.2		
Boiler power (kW)	3	3	3
Wash pump power (kW)	0.36		
Pressure increase pump power ( kW)	0.46		
Total power kW	3.36	3.36	3.36
Water supply temperature °C	50	50	40
Water hardness °F	7-12		>15
Pressure (bar)	2-4		3-4
Power voltage	230V 1N	230V 1N	230V 1N
Frequency	50 Hz		
Noise level ( dBA)	<70		
<b>STANDARD EQUIPMENT</b>			
Supply fitting ¾ "G	Yes		
Drain fitting	Yes		
Boiler safety thermostat	Yes		
Rinse aid dispenser	Yes		
Plate basket capacity 14( n°)	1		
Flat mesh basket (n°)	1		
Cutlery holder (n°)	1		
Insert for saucers	1		
<b>ACCESSORIES ON REQUEST</b>			
Cutlery basket	Yes	Yes	Yes
Detergent dispenser	Yes	Yes	Yes
Pressure increase pump	Yes	Yes	No
Drain pump	Yes	Yes	Yes
Cold rinse	Yes	Yes	Yes
<b>NRD =non-return device S= standard</b>			



ECO 5 DISHWASHER						
TECHNICAL CHARACTERISTICS	MODELS					
	51	51 T	52	52 T	56	56 T
Standard	S*		/		/	
Non-return device*	/		S*		/	
Water softener	/		/		S*	
Dimensions LxDxH ( mm)	600x625x820					
Basket dimensions ( mm)	500x500					
Useable clearance ( mm)	330					
Total cycle time (sec)	150					
Production baskets/hour	24					
Tub capacity in lt.	23					
Boiler capacity in lt.	6.9					
Consumption of water per cycle (l)	3					
Tub power (kW)	2					
Boiler power (kW)	3	4.5	3	4.5	3	4.5
Wash pump power (kW)	0.65					
Pressure increase pump power ( kW)	0.46					
Total power kW	3.65	5.15	3.65	5.15	3.65	5.15
Water supply temperature °C	50	15-50	50	15-50	40	15-40
Water hardness °F	7-12				>15	
Pressure (bar)	2-4				3,4	
Power voltage	230V 1N	400V 3N 230V 1N 230V 3N	230V 1N	400V 3N 230V 1N 230V 3N	230V 1N	400V 3N 230V 1N 230V 3N
Frequency	50Hz					
Noise level ( dBA)	<70					
<b>STANDARD EQUIPMENT</b>						
Supply fitting ¾ "G	Yes					
Drain fitting	Yes					
Boiler safety thermostat	Yes					
Rinse aid dispenser	Yes					
Plate basket capacity 20( n°)	1					
Flat mesh basket (n°)	1					
Cutlery basket (n°)	2					
<b>ACCESSORIES ON REQUEST</b>						
Cutlery basket	Yes		Yes		Yes	
Detergent dispenser	Yes		Yes		Yes	
Pressure increase pump	Yes		Yes		No	
Drain pump	Yes		Yes		Yes	
Cold rinse	Yes		Yes		Yes	

NRD =non-return device S= standard

## 8 INSTRUCTIONS FOR INSTALLERS

### 8.1 PREPARING FOR INSTALLATION

Carry out the following operations:

- place the appliance in the desired position on a solid, flat and stable floor;
- take care not to damage the appliance by banging it against nearby objects during loading and offloading operations;
- Only qualified personnel, equipped with safety measures, can be present in the area during installation;
- Remove the appliance from its packaging, taking care not to damage any protruding parts (drains, wiring, power cable);
- remove the protective film;
- Check that the appliance is in good condition. In the event of visible damage to the appliance contact the retailer and the courier responsible for delivering the product immediately. If in doubt do not use the appliance until it is checked by a specialised technician;
- transport and move the appliance using a fork-lift by inserting the forks under the appliance.
- carefully level the appliance by using the levelling feet;
- clean the appliance before using it with a cloth dampened in water and bicarbonate or other neutral detergents and dry carefully.

## 8.2 WARNINGS

- Prior to connecting the machine to the power and water supply read the general instructions and the information indicated on the data plate by the manufacturer.
- Do not leave the machine in rooms with a temperature lower than 0°C;
- The degree of protection of the machine is IP X4. Therefore it should not be washed with direct high-pressure water jets;
- In the event of damage or breakdown switch off the appliance immediately.
- Only use original spare parts to replace damaged ones..

## 8.3 LAWS, TECHNICAL REGULATIONS AND GENERAL RULES

Comply with the following during installation:

- a) safety norms;
- b) laws in force in the country where the appliance is installed;
- c) read all the indications given in this handbook carefully as they provide important information for safe installation, use and maintenance;
- d) keep this handbook in a safe place for future reference by those who use the appliance;

## 8.4 INSTALLATION

Installation, start-up and maintenance of the appliance should only be carried out by specialised personnel in compliance with the instructions provided by the manufacturer.

The manufacturer declines all responsibility if the appliance malfunctions due to incorrect installation, tampering, improper use, poor maintenance, failure to comply with the local laws and inexperience in using the appliance.

## 9 CONNECTING THE WATER SUPPLY

Prior to connecting the appliance to the water supply make sure that a gate valve or tap has been placed between the water supply system and the appliance that allow the power supply to be interrupted if needed or if repairs are required.

The water supply minimum pressure, measured when water enters the machine during the final rinse (flux pressure), should not be lower than 2 bar, even in the presence of other open taps on the same line.

We recommend that each machine is equipped with its own pipe having reduced length and a sufficiently large cross section so as to avoid pressure or load losses.

An additional rinsing pump, available as an optional item, must be installed in cases where pressure is lower than the minimum value required.

A pressure reducing valve must be installed upstream from the supply pipe in cases where static pressure is greater than 5 bar. The supply pipe of the machine must have a capacity equal or greater than 20 lt/min.

**A successful final rinse cycle is strictly dependent upon adherence to the values shown.**

The drain hose must be connected directly to the drain duct after a siphon has been interposed.

Drainage occurs by gravity, therefore the joint to the drain hose must always be positioned below the bowl level.

If the existing drain is located above the specified level an adequate drainage pump must be installed (optional).

Do not install the outlet hose in tubs, sinks etc.

## 10 CONNECTING THE ELECTRICAL SUPPLY

- 1) The units are delivered ready for working with the voltage shown on the data plate.
- 2) Connect to the electricity line, interposing a suitably rated automatic circuit breaker, where the opening distance between the contacts must be at least 3 mm. Furthermore, supply voltage must not deviate from the voltage value by +5% to -10 %.
- 3) The characteristics of the flexible cable chosen for connection to the electricity line must not be inferior to the type with rubber insulation H05RN-F and it must have a nominal cross section suitable to absorb maximum current; hence, as indicated in the table, it must have the same minimum cross section indicated relative to the model.
- 4) To access the power inlet terminal board and replace the power cord, check the positioning in the attached installation diagrams.

N.B. It is essential that the appliance is connected to an efficient earth plug. For this purpose, near the connection terminal board there is a terminal marked with a plate with the  symbol on it and to which the earth wire must be connected (yellow-green).

**ATTENTION:** The use of adaptors, multiple sockets or extension cables is strictly forbidden.  
**Check and tighten all the screws of the electric system which may have become loose during storage or transport.**

**ATTENTION: Safety device installed;** The appliances are equipped with a manual reset safety device which, in the event of an increase in temperature beyond the predefined maximum limit, cuts in, thus interrupting the power supply to the heating elements.  
The event is signalled by the switching off of the light during normal operation.

## 11 EQUIPOTENTIAL CONNECTION

If several appliances are installed in a row, the appliance must be connected to an equipotential system whose effectiveness must be verified in accordance with the relative current laws. The connection is at the back of the appliances and marked with the "EQUIPOTENTIAL" plate.

**NOTA:** the manufacturers decline all responsibility if the accident prevention rules described above are not complied with!

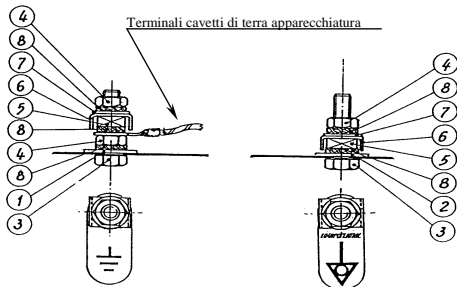

## 12 ADJUSTMENTS AND CHECKS

The temperature inside the bowl is set at 55/60°C.

This temperature favours the correct use of the chemical characteristics of all industrial detergents.

It is advisable not to change this parameter.

The temperature of the boiler is set at 87-90°C.

This value allows the rinse water temperature to be optimized throughout the cycle.

### 12.1 Rinse aid dispenser

The appliance is equipped with a fully automatic rinse aid dispenser.

Before starting the appliance make sure that the rinse aid suction tablet is inserted to its container.

During the manufacturing process the dispenser is calibrated for maximum opening and must be then adjusted according to the water hardness.

**Calibration:** Turn the adjustment screw anticlockwise to increase the capacity and clockwise to decrease it. A perfect dosage is obtained by turning the adjustment screw by approximately 90 degrees.

An excessive dose of surfactant leaves blue streaks on the crockery and leads to the formation of foam in the bowl.

On the other hand, if crockery is covered with water droplets and drying is slow it means that the dose of surfactant is insufficient.

**Before setting the right amount of surfactant to be used, it is advisable to carry out a specific test to determine the degree of water hardness.**

**If the hardness of the water is greater than 15°F. (French degrees), we advise to install a decalcifier upstream from the supply solenoid valve of the machine.**

Considering that the amount of surfactant varies sensibly according to its concentration and type of formulation, the values listed in this manual are totally indicative and must only serve as guidance.

The instructions supplied with the surfactant used will provide useful information on how to determine the necessary dose.

In order to determine the exact amount of product, once the suction has been carried out, remove the transparent tablet from the surfactant container and measure the shift in the internal column of liquid.

The doses shown have been calculated on the basis of the characteristics of a good product available on the market (with a recommended concentration of 1.5g. per 10lt. of rinse water) and to a water hardness of 10-12°F.

Given that 1g. of product (1cm<sup>3</sup>) is equal to 8 cm in the liquid column inside the transparent suction tablet, the indicative amounts for the various models are as follows:

	<b>CONSUMPTION of H<sub>2</sub>O RINSE (l)</b>	<b>AMOUNT OF PRODUCT (cm)</b>
L 45	2,6	5
ECO 4	2,2	4
ECO 5	3	6

## 12.2 Loading the detergent

Pour the required amount of detergent into the dishwasher by following the instructions provided by the manufacturer.

If powder detergent is used make sure that it is evenly distributed in the bowl and does not deposit on one single area in order to avoid the formation of dark stains at the bottom; shake the water.

Considering that the dosage varies sensibly (0.8-2.5 grams/litre) according to the product concentration and type of formulation, the amounts shown are purely indicative.

### EXAMPLE OF DOSAGE WITH 2 g/litre

	<b>CAPACITY TUB (l.)</b>	<b>INITIAL DOSE</b>	<b>EVERY 5 WASH CYCLES</b>
L 45	1,8	g 36	g 17
ECO 4	8	g 18	g 15
ECO 5	23	g 40	g 20

Use only specific anti-foam detergents in the appropriate doses.

## 13 DISPENSER FOR LIQUID DETERGENT (optional)

### 13.1 Start-up

Before adjusting the detergent dispenser (optional), this and the corresponding small supply pipe must be filled as follows:

Supply voltage to the machine.

The dispenser is connected in parallel with the load/rinse solenoid valve.

DO NOT insert the overflow in the drain hole and run the water until the small transparent plastic pipe and the dispenser are filled.

Check the detergent concentration and the supply water hardness by referring to the product data sheet before adjusting the dispenser.

Follow the manufacturer's instructions carefully.

The amount of detergent poured into the bowl depends on the amount of water consumed by the machine during each rinse cycle.

The amount required may range between 0.8 and 2.5 grams/litre depending on the detergent type and concentration.

### 13.2 Operation

Since the control is parallel to the load/rinse solenoid valve, when the machine is filled with water, the dispenser adds the detergent according to the amount established by the manufacturer.

When the rinse cycle starts, the load/rinse solenoid valve allows the dispenser to replenish the detergent in the bowl.

**N.B.** The setting of the operation of the dispenser must find a balance between the initial loading and replenishing, by adjusting the operating time in relation to the intervals.

**One second of dispenser operation corresponds to the input of one gram of product**

### 13.3 How to regulate the detergent dispenser

The regulator was designed to allow the dosage of detergent that normally flows through the dispensing pumps.

Specifically this regulator carefully balances the two amounts of detergent (the initial and replenish ones) which periodically are loaded into the machine.

By fully turning the timer anticlockwise the pump is always off, whereas by turning fully it clockwise the pump is always on.

The intermediate settings of interval/operation are exemplified in the diagram below:

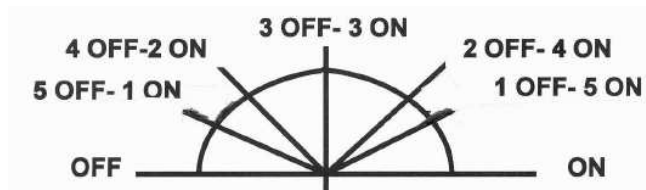

### 13.4 Example of how to set the amount of detergent required

Measure the water consumption of each rinse cycle by referring to the technical sheet of the appliance.

For example, let us assume that the consumption is equal to 2 litres:

2 lt of water x 1.5g (hypothetical amount of detergent recommended by the manufacturer for every litre of wash water, taken from the product technical sheet) = 3 (gr. of detergent).

Given that 1 gr. = 1 cc. of detergent takes up 8 cm. of the transparent supply tablet of the dispenser, this leads to: 3 (gr. of detergent) x 8 (cm. of tablet) = 24 (cm. of tablet corresponding to the volume of required detergent).

The setting must be carried out so that the appliance produces an amount of detergent equal to 24 cm. in length of the supply tablet, for every rinse cycle.

By following the same criteria, the consumption of every other dishwasher model can be calculated.

**N.B. The data provided above refers to a standard supply tablet with a diameter of 5 mm**

The amount of detergent is right when the crockery is free from any food residues at the end of the wash cycle.

An excessive amount of detergent can give rise to the build-up of foam in the bowl and leave white streaks on the crockery.

Insert the overflow in its housing and carry out some trial cycles.

Perfect wash results can be guaranteed by gradual setting.

**N.B. Extra care must be taken in achieving a perfect balance between the amount of rinse aid and the amount of detergent.**

Do not immerse your hands in the wash lye. Should this happen rinse immediately with plenty of water.

Place the dishes with the cavity facing upwards and the cups and glasses upside down.

Place the saucers in the appropriate rack support and the knives and tea spoons in the cutlery basket with the point facing downwards.

Do not place silver and stainless steel cutlery in the same container as this may cause silver to burnish and stainless steel to corrode. If possible, wash glasses and glass dishes before the wash cycle.

Place the various types of crockery into the appropriate baskets (plates, glasses, mugs and cups, saucers, cutlery etc.).

In order to save detergent and energy only start a wash cycle when the dishwasher is full without overloading the racks and avoiding any overlapping of crockery.

In order to keep maintenance to a minimum, WE ADVISE TO CLEAN THE CROCKERY BEFORE LOADING THE MACHINE; by removing food, lemon peel, toothpicks, olive pits etc. which could partially obstruct the filter of the solenoid valve, thus compromising the washing performance, the quality of the final result will improve considerably.

**Remove all food residue from the crockery.**

**Leave the dishes and cutlery with dried-on food residue to soak in water before loading the rack.**

Place the basket in the dishwasher, shut the door and start the wash cycle.

## **14 FUNCTIONAL CHECKS**

Before operating the machine it is appropriate to follow the testing procedure below:

- 1) CHECKING THE WATER LEVEL:
  - During the filling of the bowl, the water must stop flowing into the bowl when its level is at least 1 cm below the level of the overflow.
  - To protect the heating element while the bowl is being drained, the load solenoid valve must start operating again when the water level is 2 cm above the heating element.
- 2) CHECKING THE RINSE CYCLE:
  - The rinse arms must rotate freely and all the sprayers must work correctly.
- 3) CHECKING THE WASH CYCLE:
  - The wash water must be distributed with high pressure by all the sprayers.
  - The wash arms must rotate freely under the water pressure.
- 4) CHECKING THE TEMPERATURE LEVELS:
  - The rinse and wash water temperature levels must correspond to the data highlighted in the "Adjustments and checks" chapter
- 5) CHECKING THE DISPENSER/DISPENSERS:
  - During each cycle, the dispenser must intake the correct amount of surfactant and/or detergent. To this end, it is useful to remember that 8 cm. of the transparent supply tablet with a cross-section of 5x8 mm. contain approximately 1 gram of product (1 cm<sup>3</sup>).
  -
- 6) CHECKING THE WASH RESULTS:
  - The wash results must be visibly satisfactory and the wash cycle must ensure that every possible food residue is removed from the surface of the crockery.
  - The rinse cycle must remove small residues of food and detergent from the crockery.
  - At the end of the cycle, the perfectly clean crockery must dry almost instantly by evaporation as soon as the basket is extracted from the machine.

**16 CONTROL AND COMMAND PANELS**

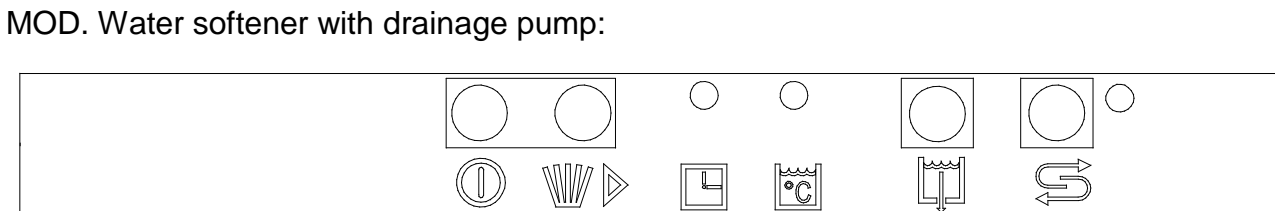
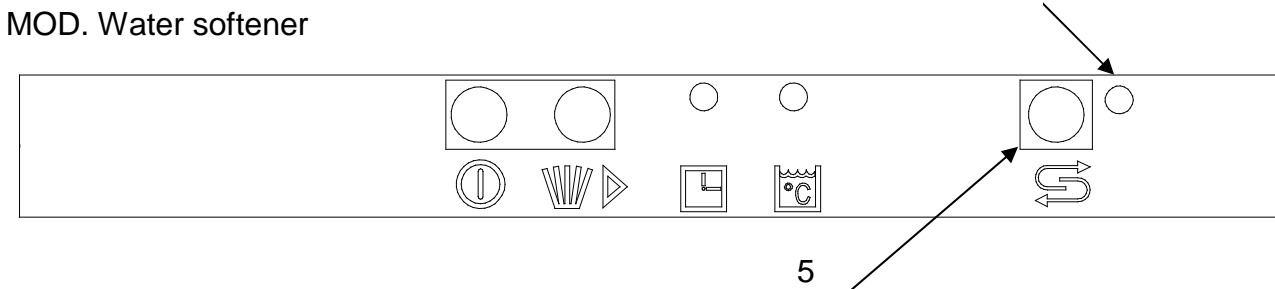
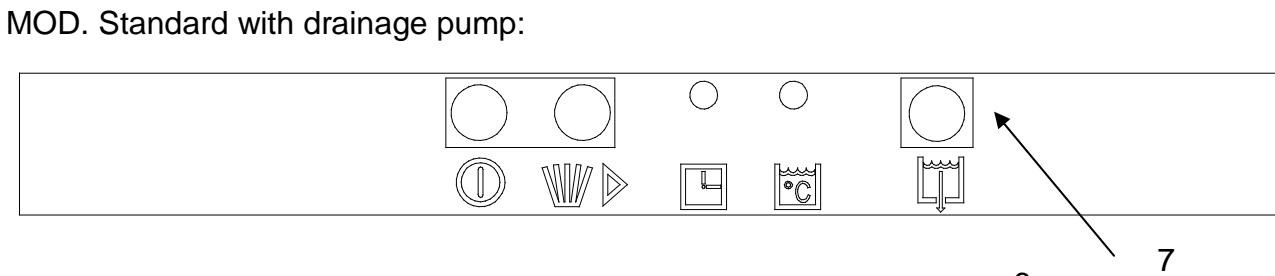
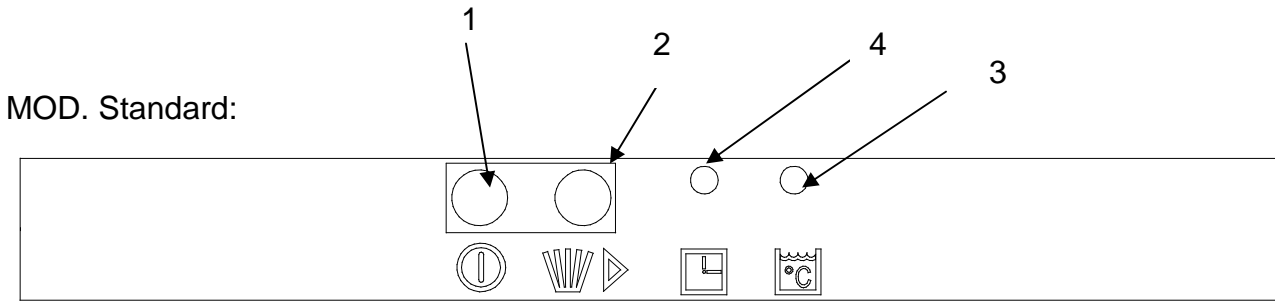

- Table: 1 - ON-OFF Switcher**  
**2 - Start-up button**  
**3 - Yellow indicator light machine ready**  
**4 - Yellow indicator light machine running**  
**5 - Regeneration cycle start-up button**  
**6 - Yellow indicator light regeneration in progress**  
**7 - Drainage pump button**

## 17 SETTING IN OPERATION:

1. Supply voltage through the main switch upstream from the appliance.
2. Turn the water tap on.
3. Make sure that the filter and the overflow are placed in the correct position.
4. Shut the door and press switch 1; the machine starts filling up with water and detergent.
5. Once the machine has been loaded (from 2 to 4 minutes depending on the type of machine and the supply pressure) the boiler heating elements automatically come into effect followed by the bowl heating element once the boiler temperature (90°C) has been reached.

If it is necessary to open the door when the machine is running **AVOID DOING IT TOO QUICKLY.**

Although the appliance is equipped with a safety switch to prevent the door from opening suddenly, spurts of water could still reach the user in the event of a hasty manoeuvre.

The machine is equipped with a programmer which switches on by briefly pressing the cycle 2 start up button

### NORMAL OPERATING CYCLE:

Once the machine is ready to operate as per the "SETTING IN OPERATION" paragraph, follow the instructions below to run the desired wash cycles :

- Insert the rack with the soiled crockery and shut the door;
- Press the cycle 2 start-up button. The indicator light (4) will illuminate signalling that the machine has started the desired wash cycle.

Once the cycle has finished, the indicator light (4) will switch off.

Open the door, extract the rack with the clean crockery and insert another rack, which has been previously loaded, into the dishwasher for the next wash cycle.

**N.B. : If the instructions have been followed correctly the crockery will be perfectly clean, dry and hygienically safe. In order to avoid wasting these efforts, make sure that crockery is stored in areas having the same requisites.**

## 18 DECALCIFICATION AND REGENERATION OF RESINS

Some dishwasher models are equipped with a system for water decalcification and the regeneration of ion exchange resins in salt water.

**DECALCIFICATION :** the system is designed for decalcifying the inlet water that runs through the boiler (without any external intervention).

**REGENERATION OF RESINS:** a regeneration of ion exchange resins in the decalcifier is required at regular intervals depending on the hardness of the inlet water (see table) and must be carried out as follows:

- a) Switch off the machine by pressing switch 1
- b) Remove the overflow to drain the bowl
- c) Once the bowl is empty, unscrew the threaded cap (located inside at the bottom of the bowl) and pour in 1 kg of sodium chloride (large-grained kitchen salt). One load is generally sufficient for  $\frac{3}{4}$  regenerations.
- d) Shut the door and press button 5 until indicator light 6 remains on.
- e) After approximately 20 seconds indicator light 6 switches off signalling that the regeneration process has terminated.
- f) With switch 1 onto the ON position, shut the door and, once the overflow has been removed, run the water for approximately 1 minute to rinse the bowl.
- g) In the case of machines equipped with a drainage pump hold button 7 down until the bowl is completely empty.
- h) Normal operation can be resumed by following the instructions at paragraph "SETTING IN OPERATION"

**N.B. : It is advisable to perform the regeneration process during periods in which the machine is not used. Failure to carry out the regeneration process according to pre-defined intervals will cause the decalcifier to clog up and the amount of water supplied to the rinse jets to decrease.**



**THE AUTONOMY OF THE DECALCIFER IS STRICTLY DEPENDENT ON THE CHARACTERISTICS OF THE SUPPLY WATER, FOR EXAMPLE :**

Inlet H <sub>2</sub> O hardness	No. of cycles	Outlet H <sub>2</sub> O hardness
F 15 D 8.4 UK 10.5	85	F 8 D 4.5 UK 5.5
F 25 D 14 UK 17.5	60	F 8 D 4.5 UK 5.5
F 35 D 19.6 UK 24.5	40	F 8 D 4.5 UK 5.5

$$1^{\circ}\text{FRENCH} = 0.56^{\circ}\text{German} = 0.7^{\circ}\text{English} = 10 \text{ p.p.m.}$$

We also recommend the use of a machine with no integrated purifier and the installation of a separate purifier with capacity equal or greater than 12 l.

## 19 DRAINAGE PUMP

The exceeding water which enters the bowl at the start of a rinse cycle is automatically drained. Follow the instructions below to drain the bowl completely:

1. Remove the overflow (not the filter)
2. Switch off the machine by pressing the ON-OFF 1 switch
3. Hold button **7** down for as long as it is necessary

**In models equipped with an inlet water decalcification system and drainage pump, the water is automatically drained from the bowl during the regeneration cycle.**

## 20 ADVICE TO USERS

### 20.1 Periodic maintenance

Disconnect the appliance from the power supply before carrying out any cleaning or maintenance operations.

Remove the washing impellers every 2-3 days and make sure that there are no food deposits inside. Check the slits and clean thoroughly if necessary.

Make sure that the rinse arm can rotate freely.

Remove any residues that may obstruct the holes of the nozzles by gently using a thin point.

The external surfaces of the machine may be cleaned using non-abrasive products which are specifically designed for stainless steel maintenance.

Use a damp cloth avoiding spilling water on the control panel.

**Do not clean the machine with pressure water jets.**

Any marks on the appliance interior may be removed using a cloth dampened with water.

Do not use **corrosive products** such as sodium hypochlorite (bleach) or hydrochloric acid (muriatic acid), steel wool or brushes.

Any disincrustation of the dishwasher must be carried out only by a specialised technician.

High quality products must be used, which are specifically designed by the best manufacturers of industrial cleaning equipment.

In case of dirt particles check that:

- The washing nozzles are clean;
- The washing temperature is approximately 60°C;
- The active chlorine detergent has been measured out correctly and is suitable for industrial cleaning.

- The pump suction filter is clean;
- The crockery has been placed in the appropriate rack;
- The crockery has been arranged well.

If the machine is left unused for extended periods, drain the water from the boiler and the electric pump and apply some Vaseline on the stainless steel surfaces.

**N.B. : These operations must be carried out only after power has been removed from the appliance by setting the main switch upstream from the machine into the “OFF” position.**

## 21 SERVICE MANUAL AND ADVICE FOR TROUBLESHOOTING

Whenever the appliance fails to work, check for a solution from the following list so as to be able to give the Technical Assistance Centre useful information for troubleshooting. The most recurring causes of malfunction are:

- A) BY SETTING THE SWITCHER INTO THE ON POSITION THE MACHINE DOES NOT START
- B) THE WATER DOES NOT ENTER THE DISHWASHER
- C) WATER KEEPS ENTERING THE DISHWASHER
- D) THE WATER DOES NOT HEAT UP (MONO-PHASE MACHINE)
- D1) THE WATER DOES NOT HEAT UP (TRI-PHASE MACHINE)
- E) THE WATER OVERHEATS
- F) THE WASH ELECTRIC PUMP IS FAULTY
- G) THE MACHINE DOES NOT RINSE
- H) THE MACHINE RINSES UNINTERRUPTEDLY
- I) THE WASH RESULTS ARE UNSATISFACTORY
- J) THE WATER DISPENSER OF THE SURFACTANT IS FAULTY
- K) THE ELECTRIC DISPENSER OF THE DETERGENT IS FAULTY
- L) THE REGENERATION CYCLE DOES NOT START
- M) THE DRAINAGE PUMP IS FAULTY

Once the area where the anomaly has presumably occurred, has been identified, proceed as indicated in the tables below.

### A BY SETTING THE SWITCHER INTO THE ON POSITION THE MACHINE DOES NOT START

POSSIBLE CAUSE	SPECIFIC SOLUTION
<ul style="list-style-type: none"> <li>• There is no voltage in the electrical system, or the main switch is disconnected or the corresponding fuses are burned-out;</li> <li>• The machine connecting cable may be interrupted;</li> <li>• The conductors in the control panel terminal board may be loosened;</li> <li>• The machine line switch is inefficient;</li> <li>• The conductor contacts are inefficient;</li> <li>• Door micro may be faulty.</li> </ul>	<ul style="list-style-type: none"> <li>• Check;</li> <li>• Replace;</li> <li>• Check and tighten;</li> <li>• Replace;</li> <li>• Check and replace</li> <li>• Replace.</li> </ul>

### B THE WATER DOES NOT ENTER THE DISHWASHER

POSSIBLE CAUSE	SPECIFIC SOLUTION
<ul style="list-style-type: none"> <li>• There is no water in the water system or the tap is closed;</li> <li>• The supply pipe may be bent or compressed;</li> <li>• The filter of the solenoid valve may be dirty;</li> <li>• The coil of the solenoid valve may be broken;</li> <li>• The small piston of the solenoid valve may be blocked.</li> <li>• Connections on the circuit may be faulty;</li> <li>• The pressure switch is faulty.</li> </ul>	<ul style="list-style-type: none"> <li>• Check;</li> <li>• Check;</li> <li>• Remove and clean;</li> <li>• Replace;</li> <li>• Remove and check;</li> <li>• Check all connections;</li> <li>• Replace.</li> </ul>

### C WATER KEEPS ENTERING THE DISHWASHER

POSSIBLE CAUSE	SPECIFIC SOLUTION
<ul style="list-style-type: none"> <li>The solenoid valve is dirty;</li> <li>The membrane is torn;</li> <li>The small piston does not move into its housing.</li> <li>Loose connection between small tube and pressure switch;</li> <li>The air trap or the small tube are pierced;</li> <li>There is water in the pressure switch or in the air supply tube;</li> <li>Loss of pressure in the pressure switch;</li> <li>The pressure switch is faulty.</li> </ul>	<ul style="list-style-type: none"> <li>Remove the solenoid valve and clean the membrane compensation cutout. Replace, in the case of a sealed solenoid valve;</li> <li>Replace;</li> <li>Check and replace the solenoid valve if necessary.</li> <li>Slightly shorten the tube and re-insert it by tightly fastening the strap;</li> <li>Replace;</li> <li>Remove the small tube and blow the internal water away. Remove the pressure switch and try to expel the water from the inside. Replace if necessary;</li> <li>Unload the dishwasher completely and reload it;</li> <li>Replace;</li> </ul>

### D THE WATER IN THE BOILER AND/OR BOWL DOES NOT HEAT UP (MONO-PHASE MACHINE)

POSSIBLE CAUSE	SPECIFIC SOLUTION
<ul style="list-style-type: none"> <li>The boiler thermostat may be faulty;</li> <li>The bowl thermostat may be faulty;</li> <li>The safety thermostat may be faulty;</li> <li>The pressure switch contact may be faulty ;</li> <li>The safety thermostat has failed to cut in;</li> <li>The connections or conductors may be faulty;</li> <li>The boiler heating element may be damaged;</li> <li>The bowl heating element may be damaged.</li> </ul>	<ul style="list-style-type: none"> <li>Replace;</li> <li>Replace;</li> <li>Replace;</li> <li>Replace;</li> <li>Reset and check the anomaly;</li> <li>Check;</li> <li>Replace;</li> <li>Replace;</li> </ul>

### D1 THE WATER IN THE BOILER AND/OR BOWL DOES NOT HEAT UP (TRI-PHASE MACHINE)

POSSIBLE CAUSE	SPECIFIC SOLUTION
<ul style="list-style-type: none"> <li>A phase is missing from the relay coil;</li> <li>The relay coil may be interrupted;</li> <li>The boiler thermostat may be faulty;</li> <li>The pressure switch contacts may be faulty;</li> <li>The relay contacts may be worn-out;</li> <li>The connections or conductors may be faulty;</li> <li>There is one phase missing;</li> <li>The boiler heating element may be damaged;</li> <li>The connection between the terminals and the heating element is incorrect.</li> </ul>	<ul style="list-style-type: none"> <li>Check;</li> <li>Check;</li> <li>Replace;</li> <li>Replace;</li> <li>Replace the contactor;</li> <li>Check;</li> <li>Check the appropriate circuit;</li> <li>Replace;</li> <li>Check;</li> </ul>
<ul style="list-style-type: none"> <li>The bowl heating element may be damaged;</li> <li>The connections or conductors may be inefficient;</li> <li>The bowl thermostat is in the "O" position (OFF), or is damaged;</li> <li>The contact on the boiler thermostat is incorrect.</li> </ul>	<ul style="list-style-type: none"> <li>Replace;</li> <li>Check the bowl contactor and thermostats;</li> <li>Adjust or replace;</li> <li>Replace;</li> </ul>

**E THE WATER IN THE BOILER AND/OR BOWL OVERHEATS**

POSSIBLE CAUSE	SPECIFIC SOLUTION
<ul style="list-style-type: none"> <li>The contacts in the boiler and/or bowl thermostat are locked in the “Closed” position.</li> </ul>	<ul style="list-style-type: none"> <li>Replace;</li> </ul>
<ul style="list-style-type: none"> <li>The relay has remained in the “Closed position”, even though voltage is supplied to the coil.</li> </ul>	<ul style="list-style-type: none"> <li>Check the closure contacts and replace if necessary;</li> </ul>

**F THE WASH ELECTRIC PUMP IS FAULTY**

POSSIBLE CAUSE	SPECIFIC SOLUTION
<ul style="list-style-type: none"> <li>The thermal protection is disconnected;</li> <li>The door micro is faulty;</li> <li>The cam of the programmer does not close the corresponding contact.</li> <li>The condenser is faulty;</li> <li>The motor winding is faulty.</li> </ul>	<ul style="list-style-type: none"> <li>Replace;</li> <li>Replace;</li> <li>Replace;</li> <li>Replace;</li> <li>Replace;</li> </ul>
<ul style="list-style-type: none"> <li>The rotor does not rotate properly and absorption exceeds the nominal values;</li> <li>The motor rotor is blocked;</li> <li>There is insufficient water in the bowl;</li> <li>The pump suction filter is dirty;</li> <li>The pump and the washing impellers are dirty.</li> </ul>	<ul style="list-style-type: none"> <li>Remove and clean the coil and replace the seal and the bearings. Check that the motor has been set at the system voltage. Remove any residues. Check that all phases are present;</li> <li>Make sure that there are no large food deposits or cutlery in the body of the pump. Make sure that the mechanical seal and shaft bearings are not blocked;</li> <li>Make sure that the overflow is perfectly tightened. Make sure that the pressure switch prevents water from entering the bowl at 1 cm from the overflow level;</li> <li>Make sure that the dishes are placed in the dishwasher only after they have been properly cleaned. Clean the filter regularly according to its use;</li> <li>Make sure that the machine is not used without a filter or that the filter is perfectly inserted in its housing.</li> </ul>

**G THE MACHINE DOES NOT RINSE**

POSSIBLE CAUSE	SPECIFIC SOLUTION
<ul style="list-style-type: none"> <li>There is no water in the system;</li> <li>The tap is partially closed;</li> <li>The supply pipe may be bent or squeezed;</li> <li>The filter of the solenoid valve may be dirty;</li> <li>The coil of the solenoid valve may be interrupted;</li> <li>The small piston of the solenoid valve may be blocked;</li> <li>Pressure in the system is insufficient.</li> </ul>	<ul style="list-style-type: none"> <li>Check;</li> <li>Check;</li> <li>Check;</li> <li>Remove and clean;</li> <li>Replace;</li> <li>Remove and check;</li> <li>Make sure that the system pressure is at least 2 bar. If pressure is lower, install an auxiliary rinse pump;</li> </ul>

<ul style="list-style-type: none"> <li>• Faulty connections or inefficient conductors on the coil circuit;</li> <li>• The cam of the programmer does not close the corresponding contact;</li> <li>• The cold, manual (where present) rinse pushbutton may be faulty;</li> <li>• The door micro may be faulty.</li> </ul>	<ul style="list-style-type: none"> <li>• Check;</li> <li>• Replace the programmer;</li> <li>• Replace;</li> <li>• Replace;</li> </ul>
<ul style="list-style-type: none"> <li>• There is lime in the rinse circuit;</li> <li>• The sprayers may be obstructed or the rotating arms blocked</li> </ul>	<ul style="list-style-type: none"> <li>• Check and clean. Install a decalcifier if necessary;</li> <li>• Check and clean;</li> </ul>

## H THE MACHINE RINSES UNINTERRUPTEDLY

POSSIBLE CAUSE	SPECIFIC SOLUTION
<ul style="list-style-type: none"> <li>• The solenoid valve is dirty;</li> <li>• The membrane is torn;</li> <li>• The small piston does not move properly in its housing or it is blocked.</li> </ul>	<ul style="list-style-type: none"> <li>• Remove the solenoid valve and clean the membrane compensation cutout. Replace, in the case of a sealed solenoid valve;</li> <li>• Replace;</li> <li>• Check and replace the solenoid valve if necessary.</li> </ul>

## I THE DISHES ARE NOT CLEAN

POSSIBLE CAUSE	SPECIFIC SOLUTION
<ul style="list-style-type: none"> <li>• The electric pump may be faulty or damaged;</li> <li>• The detergent is not suited to dishwashers;</li> <li>• There is no detergent in the bowl;</li> <li>• The impellers may be obstructed or damaged;</li> <li>• The washing impeller may be blocked;</li> </ul>	<ul style="list-style-type: none"> <li>• Refer to various sections in paragraph F;</li> <li>• Check the amount of detergent. Use only EXCELLENT products, specifically formulated for industrial washing by leading companies of the sector.</li> <li>• Always adhere to the doses stated on the product technical sheets. Check the corresponding dispenser where present;</li> <li>• Clean and/or replace;</li> <li>• Check and unblock;</li> </ul>
<ul style="list-style-type: none"> <li>• The water temperature is insufficient;</li> <li>• The kitchenware has been loaded incorrectly;</li> <li>• The baskets have been used incorrectly;</li> <li>• The rinse cycle has not been carried out properly. The crockery is lightly soiled;</li> </ul>	<ul style="list-style-type: none"> <li>• Adjust the thermostat by checking, through a thermometer, that the wash water temperature corresponds to the pre-set temperature when the indicator light illuminates;</li> <li>• Make sure that the crockery is arranged as per instructions and does not overlap;</li> <li>• Use the supplied specific baskets for each type of crockery and cutlery;</li> <li>• Refer to specific sections in paragraph G;</li> </ul>

<ul style="list-style-type: none"> <li>• The washing slits are partially obstructed;</li> <li>• The dishes or other crockery are overlapping;</li> <li>• There is dried-on food residue on the crockery due to late washing.</li> <li>• The wash cycle may be inefficient;</li> <li>• The rinse cycle may be inefficient;</li> <li>• The rinse water may be too hard and contain exceeding calcium and magnesium salts;</li> <li>• There is excessive surfactant concentration in the rinse water.</li> <li>• The detergent or surfactant may not be suitable for industrial dishwashers;</li> <li>• The wash water temperature may be too low.</li> </ul>	<ul style="list-style-type: none"> <li>• Remove and clean;</li> <li>• Check and separate correctly. Use the appropriate rack;</li> <li>• Soak the crockery in water and wash again.</li> <li>• Refer to various sections in paragraph F;</li> <li>• Refer to various specific sections in paragraph G;</li> <li>• Install a decalcifier upstream from the machine with adequate capacity according to the consumption of the machine itself. If the machine is equipped with a water softener make sure that the regeneration of resins is carried out regularly;</li> <li>• Adjust the dispenser according to the doses suggested by the product manufacturer. Once the dispenser has been adjusted, it is necessary to wait until the product concentration has stabilised on the new values, after a few wash cycles, before being able to notice any improvement in the quality of the rinse cycle.</li> <li>• Use a foam breaking detergent and an anti-foam surfactant;</li> <li>• Check the calibration of the thermostat that regulates the bowl temperature and the status of the bowl heating element.</li> </ul>
--	---

**J THE WATER DISPENSER OF THE SURFACTANT IS FAULTY**

POSSIBLE CAUSE	SPECIFIC SOLUTION
<ul style="list-style-type: none"> <li>• The small transparent suction tube may be bent;</li> <li>• The small suction tube may have a hole;</li> <li>• The small suction tube is not properly tightened to the rubber seal;</li> <li>• The suction fitting of the dispenser is not tightened properly.</li> <li>• Pressure in the system is insufficient;</li> </ul>	<ul style="list-style-type: none"> <li>• Check;</li> <li>• Check and replace if necessary;</li> <li>• Check and replace if necessary;</li> <li>• Check.</li> <li>• Check;</li> </ul>

**K THE ELECTRIC DISPENSER OF THE DETERGENT IS FAULTY**

POSSIBLE CAUSE	SPECIFIC SOLUTION
<ul style="list-style-type: none"> <li>• The small tube inside the dispenser may be broken;</li> <li>• The small suction tube may be bent or damaged.</li> </ul>	<ul style="list-style-type: none"> <li>• Replace the small tube;</li> <li>• Check and replace if necessary.</li> </ul>
<ul style="list-style-type: none"> <li>• Faulty connection or inefficient conductors on the motor coil circuit;</li> <li>• The cam of the programmer does not close the loading/rinsing electric contact;</li> <li>• The electronic board may be damaged.</li> </ul>	<ul style="list-style-type: none"> <li>• Check and replace if necessary;</li> <li>• Replace the programmer;</li> <li>• Replace.</li> </ul>

## L THE REGENERATION CYCLE DOES NOT START

POSSIBLE CAUSE	SPECIFIC SOLUTION
<ul style="list-style-type: none"> <li>• There is no water in the water system or the tap is closed;</li> <li>• The supply pipe may be bent or squeezed;</li> <li>• The filter of the solenoid valve may be dirty;</li> <li>• The coil of the solenoid valve may be interrupted;</li> <li>• The small piston of the solenoid valve may be blocked;</li> <li>• The connections on the coil electric circuit may be faulty;</li> <li>• The cam of the programmer does not close the corresponding contact;</li> <li>• The corresponding button does not power the programmer or there is no contact on the rotary switch;</li> <li>• The ON-OFF button does not start the regeneration cycle when on the OFF position;</li> <li>• The coil may be interrupted.</li> </ul>	<ul style="list-style-type: none"> <li>• Check;</li> <li>• Check;</li> <li>• Remove and clean;</li> <li>• Replace;</li> <li>• Remove and check;</li> <li>• Check all connections;</li> <li>• Replace the programmer;</li> <li>• Check the connections and replace the button or switch if necessary;</li> <li>• Check the connections and replace the switch if necessary;</li> <li>• Replace.</li> </ul>

## M THE DRAINAGE PUMP IS FAULTY

POSSIBLE CAUSE	SPECIFIC SOLUTION
<ul style="list-style-type: none"> <li>• The coil may be interrupted;</li> <li>• The pump may be clogged;</li> <li>• The impeller of the drain pump may be damaged;</li> <li>• The drain pipe may be obstructed.</li> <li>• The rotary switch may be faulty.</li> <li>• The drainage button may be faulty.</li> </ul>	<ul style="list-style-type: none"> <li>• Replace the pump;</li> <li>• Remove and clean;</li> <li>• Replace the pump;</li> <li>• Remove any food residue.</li> <li>• Replace;</li> <li>• Replace.</li> </ul>

The manufacturer declines all responsibility for any incorrect information herein due to printing or spelling mistakes. The manufacturers reserve the right to modify their products if necessary without compromising their basic characteristics.

It is forbidden to reproduce or photocopy, even partially, any texts or images contained in this booklet without previous insurance.

## 22 DISMANTLING - RECYCLING

In conformity with art.13 of Legislative Decree No. 151 of 25 July 2005, "Implementation of directives 2002/95/CE, 2002/96/CE and 2003/108/CE, regarding the reduction in use of dangerous substances in electrical and electronic equipment, as well as waste disposal"

Products  bearing the barred dustbin symbol must be disposed of separately from other waste. The recycling of old appliances is organised and managed by the manufacturer. Consumers should contact the manufacturer for information concerning the correct disposal of their old appliance. Separate waste collection allows used equipment to be recycled, treated and disposed of without negative consequences for the environment and health, and it allows the materials in the equipment to be recycled. Illegal dumping of the product by the user entails the administrative sanctions stated in the current legislation.

### Materials used in the manufacture of the equipment:

Stainless steel: bodywork  
 Rubber: water system piping  
 Copper: electric system  
 PA (Nylon) wash circuit