

## GLASS- AND DISHWASHERS



### ECOMAX 502L(P)

### INSTALLATION AND OPERATION INSTRUCTIONS

*(original instructions)*

# IMPORTANT NOTES

---

## THE ORIGINAL INSTRUCTIONS.

## ONLY TRAINED OR AUTHORIZED ADULT PERSONS OPERATE THE MACHINES.

## USE IN ACCORDANCE WITH REGULATIONS

The machine is technical work equipment for express use in the work place.

The machine is exclusively to be used to wash ware such as plates, cups, glasses, cutlery, trays etc.

Do not use for electrically heated cooking and heat conservation appliances.

## SAFETY:

Never hose down the machine.



---

**The “Attention” symbol is shown beside instructions that are essential for the safe operation of the machine.**

**Please read these passages thoroughly.**

---

## LIABILITY:

Installations and repairs which are carried out by non-authorized technicians or the use of other than original spare parts, and any technical alterations to the machine, may affect the warranty set out in the standard conditions of sale.

The machine can be used by one person only, does not allow two or more people operate at the same time.

## MACHINE NOISE LEVEL:

The machine noise level is  $\leq 70$  dB (A).

## USING ENVIRONMENT

Electric equipment shall be capable of operating correctly in the intended ambient air temperature. The minimum requirement for all electrical equipment is correct operation between air temperature of  $+5^{\circ}\text{C}$  and  $+40^{\circ}\text{C}$ .

The electrical equipment shall be capable of operating correctly when the relative humidity does not exceed 50% at a maximum temperature of  $+40^{\circ}\text{C}$ . Higher relative humidities are permitted at lower temperatures (for example 90% at  $20^{\circ}\text{C}$ ).

Electrical equipment shall be capable of operating correctly at altitudes up to 1000m above mean sea level.

The equipment are not used in the potential explosive environment.

## CONNECTING TENSIONS:

The machine described in this operation manual has following connecting tensions:  
400 V/50 Hz/3 Ph/N/PE or 230 V/50 Hz/1 Ph/N/PE

## GENERAL INFORMATION ON WASHING GLASSES AND CUTLERY:

The local supply water quality has a major impact on the wash and rinse result. A high content of minerals which are dissolved in the water during the drying process may become visible in the form of spots and streaks.

Authorised service personnel can determine the content of minerals by measuring the electrical conductivity. Values of less than 80 Microsiemens/cm indicate a low content of minerals. Higher contents need to be reduced below the critical level by demineralising the water using specific demineralisation cartridges or a reverse osmosis system.

Please contact your authorised service partner for support.

We recommend the use of specific glass racks. These racks hold the glasses in slightly inclined positions – this will

# IMPORTANT NOTES

---

improve the rinse efficiency.

To avoid unpleasant smelling glasses, specific chlorine-free detergent for glass washing should be used.

Before washing new glasses the first time with a commercial glass washer, intensive basic cleaning is mandatory to reduce the greasy film which is on most glasses for protection during production. If not, water drainage is impaired and streaks and spots may remain on glasses.

We recommend carrying out the basic cleaning manually in a sink (using gloves and a brush for cleaning) with a much higher chemical concentration of detergent (minimum 10 g of detergent per liter).

As continued product improvement is a policy of HOBART, specifications are subject to change without notice.

Company address: No.8 Yesheng Road, Xiqing Economic & Development Zone, Tianjin China.

---

<b>1.</b>	<b>BRIEF INTRODUCTION.....</b>	<b>5</b>
<b>2.</b>	<b>TRANSPORTATION, STORAGE AND INSTALLATIONS.....</b>	<b>6</b>
2.1.	transportation and storage.....	6
2.2.	Location .....	6
2.3.	Electrical connection.....	6
2.4.	Water connection .....	7
2.5.	Drain connection .....	7
<b>3.</b>	<b>CONTROLS .....</b>	<b>8</b>
<b>4.</b>	<b>START-UP .....</b>	<b>9</b>
4.1.	Detergent PUMP (OPTIONAL) .....	9
4.2.	Rinse aid PUMP (OPTIONAL) .....	9
4.3.	Priming the suction hoses .....	10
4.4.	Softener (optional) .....	11
<b>5.</b>	<b>OPERATION .....</b>	<b>12</b>
5.1.	Preparation .....	12
5.2.	Run .....	13
<b>6.</b>	<b>SWITCH-OFF AND CLEANING THE MACHINE.....</b>	<b>14</b>
6.1.	Switch-off.....	14
6.2.	Cleaning (daily).....	14
6.3.	Cleaning (weekly).....	14
<b>7.</b>	<b>SETTINGS .....</b>	<b>15</b>
7.1.	Adjustment of detergent dosage quantity.....	15
7.2.	Adjustment of rinse aid dosage quantity .....	15
7.3.	Adjustment of water hardness .....	16
<b>8.</b>	<b>FROST PREVENTION .....</b>	<b>17</b>
<b>9.</b>	<b>MAINTENANCE .....</b>	<b>18</b>
<b>10.</b>	<b>TROUBLESHOOTING GUIDE .....</b>	<b>19</b>
10.1.	Poor wash result .....	19
10.2.	Other faults.....	20
10.3.	Malfunctions.....	20

# 1. BRIEF INTRODUCTION

---

Introduction table:

1	Filling connection G3/4
2	Tank drain DN20
3	Power line
4	Detergent dosage
5	Rinse aid dosage

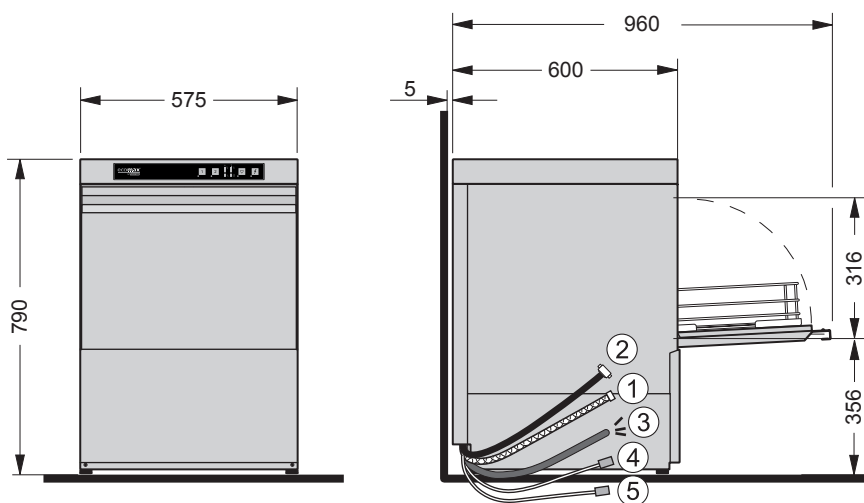

## 2. TRANSPORTATION, STORAGE AND INSTALLATIONS

---

### 2.1. TRANSPORTATION AND STORAGE

---



Forklift must be used during transportation and storage instead of vertical loading, pay attention to upturn and prevention of break, moisture and load. (See the marks on the package).

### 2.2. LOCATION

---

- Rear wall clearance not required.
- Level machine by turning the feet.
- Distribute machine weight equally onto all feet

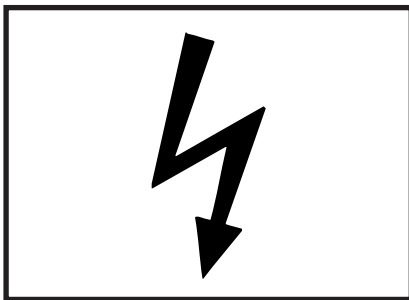

### 2.3. ELECTRICAL CONNECTION

---



**Must be carried out by an authorized technician according to the local and national codes.**

---

- The electrical supply shall comply with the name-plate data.
- Line fuses and cable cross section shall comply with the requirements.

**NOTE: The machine with or without interlock function has different working current. Please refer to the wiring diagram.**

**NOTE: A cut-off device shall be provided to connect the supply cord (isolating switch or accessible plug device). According to EN 60 335 the appliance must be connected to an equipotential conductor. The connecting screw (⚡) is located beside the cable inlet.**

## 2. TRANSPORTATION, STORAGE AND INSTALLATIONS

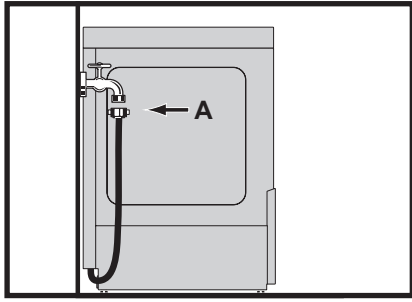

### 2.4. WATER CONNECTION



**Must be carried out by an authorized technician according to the national and local codes.**

**The machine must be operated with potable water. For water with an extremely high mineral content an external demineralisation is strongly recommended**

- Connect to warm water, if possible (max. 65°C).
- Water hardness:
  - Machines without softener: max. 3.75° Clark = 0.5 mmol/l.
  - Machines with softener: max. 37.5° Clark = 5.3 mmol/l.
- Line flow pressure  
Line flow pressure 0,5 – 6 bar.  
> 6 bar: pressure reducer valve necessary.
- Connect the union nut “A” (3/4”) of the water supply hose to the site shut off valve.
- Do not kink or cut the supply hose. If an extended supply hose is required, use one of the same specifications as the original.

**NOTE: The water hardness should be  $\leq 0.5$ mmol/L. If not, water softener is strongly recommended. Or else, may affect the warranty set out in the standard conditions of sale.**

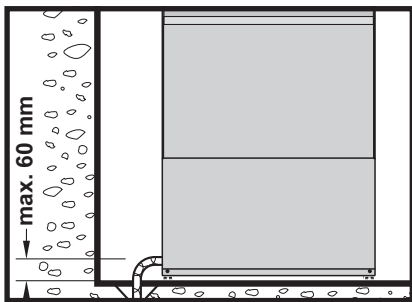

### 2.5. DRAIN CONNECTION

Machine without drain pump

- Ensure gravity drain.
- For these machine types, a floor drain is mandatory as the drain hose exits the machine at approx. 60 mm above floor level. Otherwise, residual water may remain in the tank and hose.
- Do not kink drain hose.

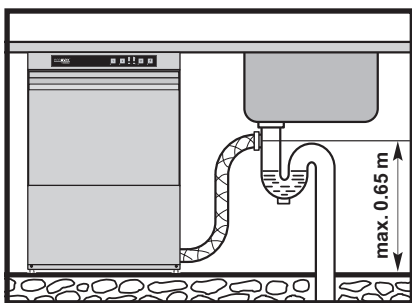

Machine with drain pump

- Connection between machine and site drain must not exceed max. height of 0,65 m.
- Do not place the drain hose loosely on the floor (the hose could be rubbed through). Fix it at site!.
- Do not kink drain hose

### 3. CONTROLS

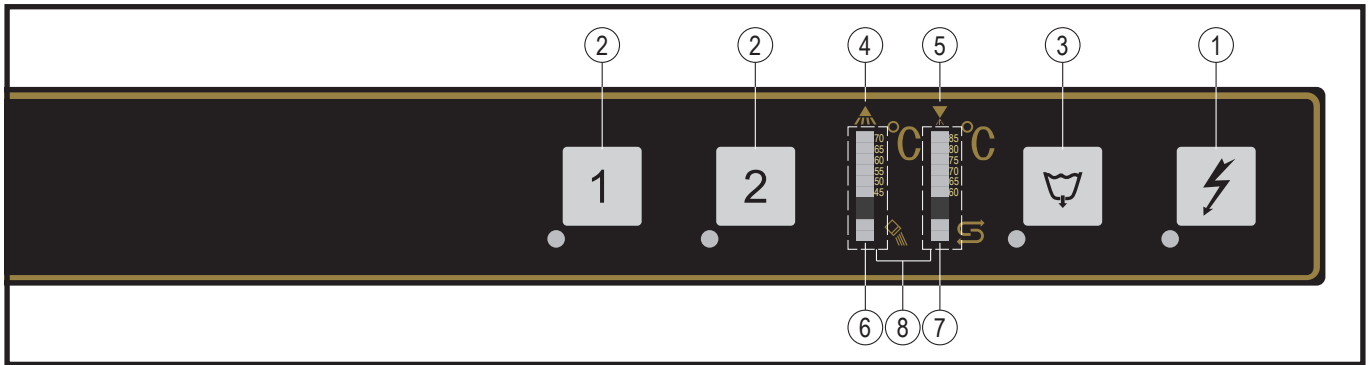

- |                                   |   |
|-----------------------------------|---|
| ① Machine ON/STOP button          | <p>Pushing this button switches the machine on.</p> <p>The LED lights up</p> <ul style="list-style-type: none"> <li>- flashing = Machine is filling and heating.</li> <li>- permanent = Maschine is ready to operate.</li> </ul> <p>In case of operating error or faults, it is possible to switch-off the machine immediately without the drain cycle, by pushing this button.</p> <p>After switch off, the machine is not voltage free!</p> |
| ② Program buttons                 | <p>By pushing these buttons, it is possible to select between short cycle (1) and standard cycle (2).</p> <p>The appropriate LED lights up.</p>   |
| ③ Drain/OFF button                | <p>By pushing and holding (3 seconds) this button, the self-cleaning cycle starts. At the end of the cycle, the machine switches off automatically. Machines with optional drain pump will drain the tank automatically.</p> <p>After switch off, the machine is not voltage free!</p>  |
| ④ Temperature indication Wash     |   |
| ⑤ Temperature indication Rinse    |   |
| ⑥ Salt required                   | <p>Indicating the need for regeneration salt to be added. (Only with built-in softener.)</p>  |
| ⑦ Regeneration indicator          | <p>Softener regeneration active. The cycle running time can extend.</p>   |
| ⑧ Indicator for setting functions | <p>The individual LEDs are also used for various settings and special functions:</p>  |

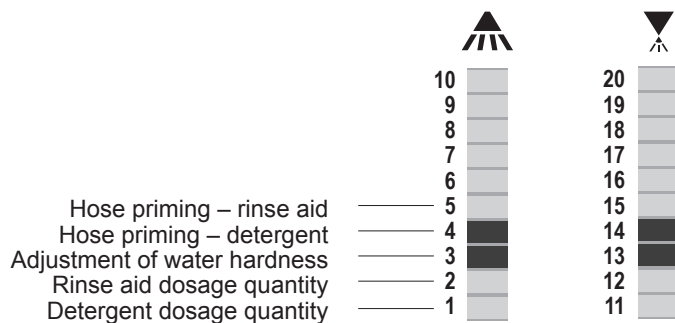

Left display: The LEDs 1 to 6 illuminate according to the selected function.

Right display: Indicates the adjusted value



## 4. START-UP

---



### **Attention:**

**The maximum suction head of the dosing pumps is 1.5 m. Do not confuse the containers**

**Use only detergent and rinse aid for commercial applications. Please pay attention to the manufacturer's safety instructions.**

---

### **NOTE:**

**Before changing to a different product type (even from the same supplier), the suction hoses must be rinsed thoroughly with fresh water (procedure as described under section 4.3.). Otherwise, the mixing of different types of chemicals will cause crystallization, which may result in a malfunction of the dosing pump.**

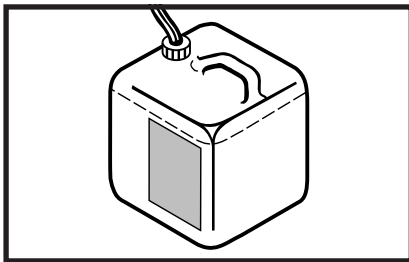

### **4.1. DETERGENT PUMP (OPTIONAL)**

---

- Do not use any acidic detergent products with the optional built-in detergent pump! (The ph-value has to be higher than 7.)
- Place the suction hose into the external detergent container. Fill the suction hose according to chapter section 4.3.

### **4.2. RINSE AID PUMP (OPTIONAL)**

---

- Place the suction hose (blue marking) into the external rinse aid container. Fill the suction hose according to chapter section 4.3.

## 4. START-UP

### 4.3. PRIMING THE SUCTION HOSES



#### ATTENTION:

The machine has to be switched off.

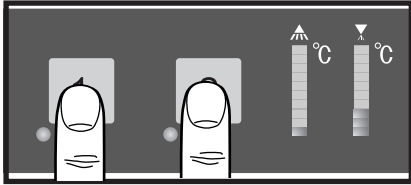

- Open the door.
- Push Program buttons ② simultaneously.
  - LEDs light up.
  - In display ⑧, the LEDs 1 and 11–20 illuminate (dependent on basic setting).



- Push Program button "1" repeatedly, until the display LED 3 lights up.
- Close the door.
- Push Program button "1" again.
  - In display ⑧ LED 4 lights up.

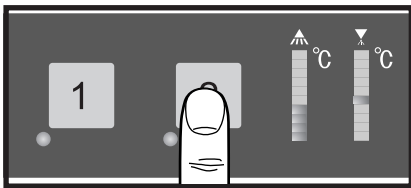

#### 4.3.1. DETERGENT SUCTION HOSE

- Only with built in detergent pump.
- Push and hold programm "2".
  - Hose will be filled.
  - moving light display ⑧ LEDs 15–18
- Releasing the button interrupts hose priming.

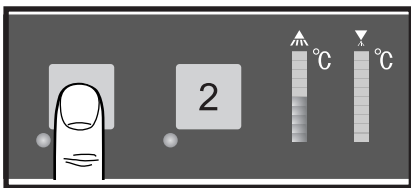

#### 4.3.2. RINSE AID SUCTION HOSE

- Push Program button "1" again.
  - In display ⑧ LED 5 lights up.

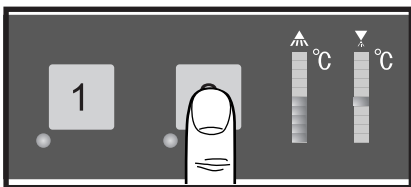

- Push and hold Program button "2".
  - hose will be filled.
  - moving light display ⑧, LEDs 15–18
- Releasing the button interrupts hose priming.
- Termination of hose priming: Open door or do not press any button for 30 seconds.

## 4. START-UP

### 4.4. SOFTENER (OPTIONAL)

**NOTE:** For the first run, the softener has to be filled with regeneration salt and potable water.



**Attention:**  
Filling the salt reservoir with cleaning agent will damage the water softener.

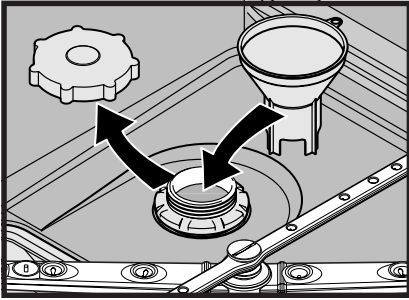

- Open the door.
- Unscrew the softener lid and fill the softener with 1.5 kg of “Granular regeneration salt” (do not use salt tablets).
- Fill up the softener with potable water (only at the first run). Clean seal and rim of softener lid carefully, before closing the lid.
- Close lid and tighten.
- In order to prevent corrosion it is necessary to remove any salt residues from tank bottom.

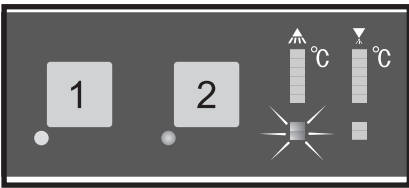

- Adjust the water hardness according to section 7.3.
- When the Salt indicator ⑥ flashes during operation, the softener has to be refilled with regeneration salt.
- There will be a slight delay before salt light goes out after refill.

## 5. OPERATION

### 5.1. PREPARATION

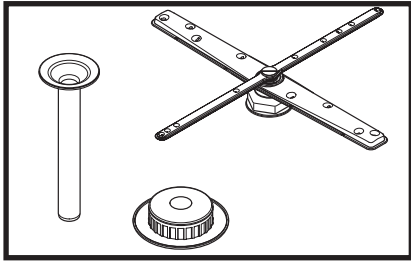

- Check correct position of wash/rinse arms, strainer and overflow pipe.
- Open shut-off valve.
- Switch on main switch or put the plug in.

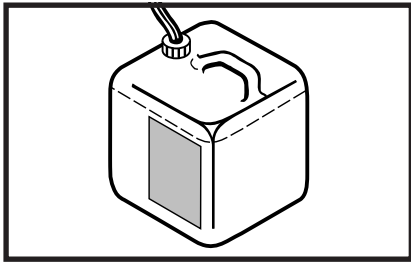

- Check level of detergent and rinse aid containers.

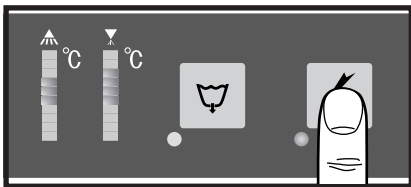

- Close door and push the ON button ①
  - tank will be filled.
  - The button LED flashes during fill and heating cycle. This process can take several minutes.
  - When the LED changes to steady burning light, machine is ready for operation.

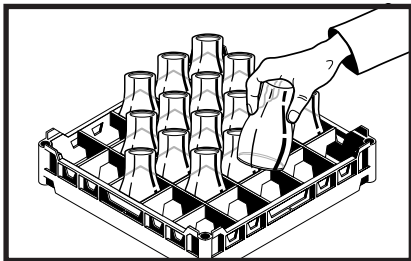

- Place glasses and cups face downwards into the rack.

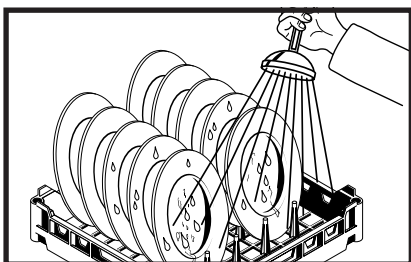

- Remove any food debris before loading plates into rack.
- Spray off greasy food leftovers.



If dishes are placed incorrectly, dishes may be not washed cleanly.

Total weight of dishes and rack should be less than 25kg, and should be placed steadily in the direction of operation to prevent human body from injury caused by falling.

## 5. OPERATION

---

### 5.2. RUN

---

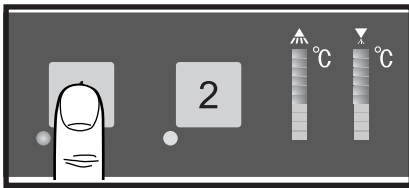
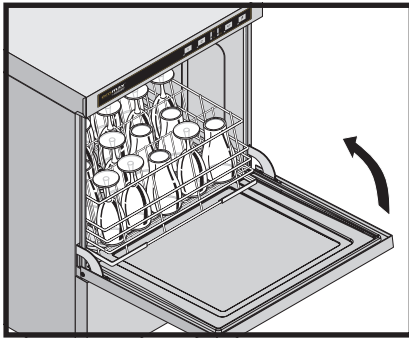

- Put rack into the machine and close the door.

- Start the desired program by selecting the program button 1 or 2

Button "1" = Short cycle

Button "2" = Standard cycle

- The Program button LED flashes, wash cycle is running.
- As soon as the LED changes to steady light, the wash cycle is finished.

- Open the door and take out rack.
- Allow dishes to dry for 1 minute approx.

- Caution labels

- Potential crushing hazard.



- Scalding and slipping hazard. Heat insulating gloves and clothes and non-slip shoes are required.

- The door is closed during wash/rinse operation; the door magnetic switch is triggered in the case of door been opened, the spray risk can be prevented from immediate stop of wash/rinse operation.

## 6. SWITCH-OFF AND CLEANING THE MACHINE

### 6.1. SWITCH-OFF

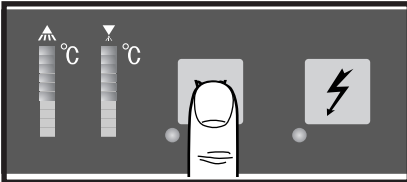
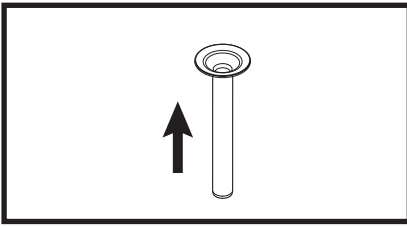

- Versions with overflow pipe: remove
- Close the door.

- Push and hold (min. 3 seconds) the Drain button ③
  - LED lights up.

The self-cleaning cycle will be started and the machine interior is cleaned automatically.

NOTE: A final inspection is recommended to remove any food debris.

- Machines with optional drain pump will drain the tank automatically.
- At the end of program, the machine switches off automatically.
- Switch off main switch or unplug. Close the shut-off valve.

### 6.2. CLEANING (DAILY)

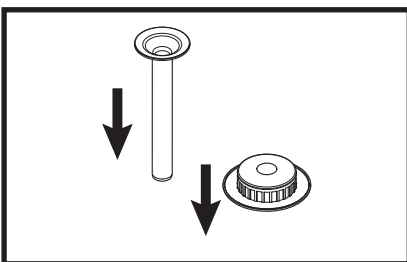

#### Attention:

To clean the machine do not use any chloric, acidic or abrasive products and no metallic brushes.

- Open door, take out strainer and overflow pipe.  
Please ensure that food debris does not enter pump intake.
- Clean interior of the machine.
- Put strainer and overflow pipe back into place.

### 6.3. CLEANING (WEEKLY)

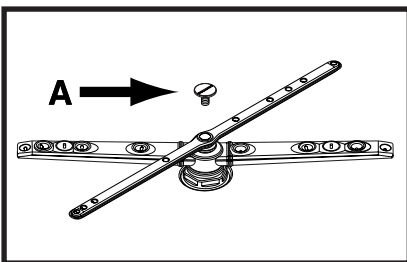

- Loosen the retaining screws (A) by turning them counter-clockwise.
- Take out and clean wash and rinse arms.
- Put all components back into place.

## 7. SETTINGS



**ATTENTION:**  
The machine has to be switched off.

- Open the door.

If the door will be closed or if no button is pressed for 30 seconds, the indicator automatically switches off and the new settings will be saved. Therefore the setting procedure can be interrupted at any time.

### 7.1. ADJUSTMENT OF DETERGENT DOSAGE QUANTITY

Only with built in detergent pump.

- Push Program buttons ② simultaneously.
  - LEDs light up.
  - In the left display the bottom LED (1) is illuminated.
  - The right display indicates the adjusted value of the detergent dosage time: One LED corresponds to approx. 3.5 s  $\approx$  1 g/l
- Pre-adjusted value: “11–13” = 10.5 s  $\approx$  3 g/l.
- To adjust the detergent dosage time, push Program button “2” repeatedly, until the desired value (0–35 s  $\approx$  0–10 g/l) is indicated.  
Adjustment should be done in accordance with chemical suppliers recommendations.

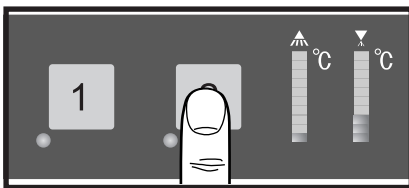
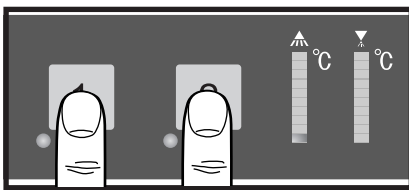

### 7.2. ADJUSTMENT OF RINSE AID DOSAGE QUANTITY

- Push Program button “1”.
  - In display ⑧ LEDs 1 and 2 illuminate.
  - the right display indicates the adjusted value of the rinse aid dosage time: One LED corresponds to approx. 2.5 s  $\approx$  0,1 g/l.
- Pre-adjusted value: “11–13” = 7.5 s  $\approx$  0,3 g/l.
- To adjust the rinse aid dosage time, push Program button “2” repeatedly, until the desired value (0–25 s  $\approx$  0–1.0 g/l) is indicated  
Adjustment should be done in accordance with chemical suppliers recommendations.

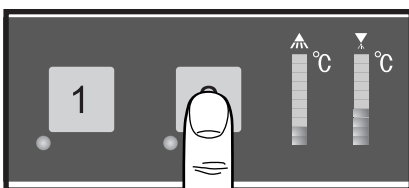
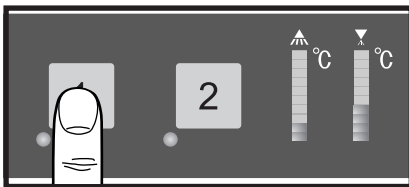

## 7. SETTINGS

### 7.3. ADJUSTMENT OF WATER HARDNESS

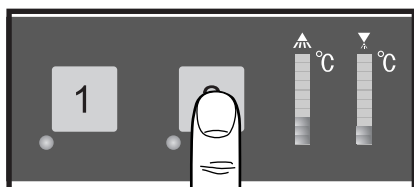
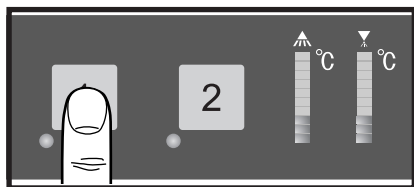

- With optional softener only.
- To adjust the softener to the local water hardness (obtain details from local water authority):
- Push Program button “1”.

LEDs 1 to 3 illuminate in the left display

- Push Program button “2” repeatedly, until the LEDs in display ⑧ correspond to the required value.

LED "on"	Range	Water hardness*
11	H01	up to 7°eh
11 and 12	H02	8 to 14°eh
11 to 13	H03	15 to 21°eh
11 to 14	H04	22 to 30°eh

\* (°eh = Clark)



## 8. FROST PREVENTION

---

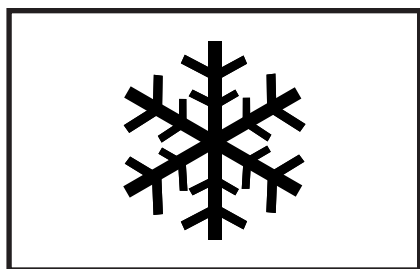

---

**This should be carried out by service personnel!**

---

In case of frost or longer operation pauses (e.g. for seasonal operations) the machine must be completely drained.

Reset for operation according to section section 3..

## 9. MAINTENANCE

---



In order to maintain the warranty, as well as a permanently safe, efficient, and trouble-free operation of the machine, the required maintenance must be carried out by authorized service technicians.

For this reason, we recommend the conclusion of an inspection and maintenance contract which assures qualified support by specially trained service technicians according to a time scheduled based on the operating conditions.



For pumps, motors, power connector and other parts, you must disconnect the power before repair.

# 10. TROUBLESHOOTING GUIDE

## 10.1. POOR WASH RESULT

TYPE OF FAILURE	POSSIBLE CAUSE	REMEDY
Washware are not clean.	Wash arms stiff (you should be able to turn them easily by hand).	Take out wash arms and clean them thoroughly. Check water outlet from machine to wash arms is clear.
	Wash arm nozzles are clogged (visual check).	Take out wash arm, remove cleaning cap and rinse the wash arm thoroughly until soil is removed. Replace correctly.
	Rinse arm nozzles are clogged (possibly by lime deposit)	Remove rinse arms and decalcify them in separate container.
	Detergent concentration is too low or too high.	Check setting of detergent concentration. See also operating instructions point 6.1.
	Coarse strainer soiled.	Take out strainer, empty and clean it.
	Wrong program selected for heavily soiled washware.	Select program with longer wash cycle.
Dishes or glasses do not dry properly.	Rinse aid concentration too low.	Increase concentration. See also operating instructions point 6.2.
	Items to be washed still greasy.	Detergent concentration too low: increase (see instructions). Check if detergent is appropriate. If not choose a stronger one. Drain soiled water and refill machine. Check pre-scrapping procedure.
	Rack is not suitable for type of washware.	Use appropriate racks to create a sloping position which allows water to drain away from cavities.
	Washware stays too long in the machine at the end of program.	Take out washware as soon as cycle is completed to enable the ware to dry.
Stripes and stains on dishes or glasses.	Rinse aid concentration too high.	Reduce quantity (see instructions).
	Hard water or high mineral content.	Check water quality. Obtain details from local water authority. Recommended values: Ideal degree of hardness is 4° Clark. Ideal conductivity value for glasses is max. 150 µS/cm and for dishes max. 400 µS/cm.
	Rack is not suitable for type of washware.	Use appropriate racks to create a sloping position which allows water to drain away from cavities.
	Insufficient rinse aid concentration causes stains	Increase quantity (see instructions)
	Machine with softener: Wrong type of salt used.	Use only granular regeneration salt.

# 10. TROUBLESHOOTING GUIDE

---

## 10.2. OTHER FAULTS

---

TYPE OF FAILURES	POSSIBLE CAUSE	REMEDY
Glasses are totally or partially cloudy	Surface of glasses is rough and porous, this is called glass corrosion	This is not caused by a malfunction on the machine. Replace with new glasses.
Glass breakages.	Use of inappropriate dish or glass racks.	Use appropriate racks.

## 10.3. MALFUNCTIONS

---

TYPE OF FAILURES	POSSIBLE CAUSE	REMEDY
Machine suddenly stops during wash program.	Machine is connected to an energy management system which cuts out the energy consumer at a given point, or machine is interlocked with another energy consumer unit.	Connect machine separately (call electrician).
	Blown site fuse.	Check site fuses.
	Temperature probe rinse booster or tank defective.	Call the after sales service.
	Pressure transmitter rinse booster or tank defective.	Call the after sales service.
The four button LEDs flash.	Control defective.	Call the after sales service.



HOBART China  
No.8 Yesheng Road, Xiqing Economic  
& Development Zone, Tianjin China  
Tel. 022-23974912/13/14/15  
Fax 022-23974917  
E-Mail: [info@hobart.cn](mailto:info@hobart.cn)  
Internet: [www.hobart.cn](http://www.hobart.cn)

As continued product improvement is a policy of HOBART,  
specifications are subject to change without notice.



## Dishwasher Maintenance

For AMX/AM900 H502L/E502L AM50E/AM60E

Clean machine(Customer)	
Items	Content
1	Tank flat strainer Visual inspection & cleaning
2	Wash tank housing Visual inspection (lime deposits etc.)
3	Wash & rinse arms Removing & cleaning of upper and lower wash arms. Tighten screws when installing.
4	Overflow & Tank strainer Check overflow tube in right place
5	Milled nut Check wash arm milled nut before operation, and tight it.

Machine inspection (Service)		Machine maintenance after 0.5 year or 20 000 cycles. The maintenance must be carried out by authorized service technicians.	
Component	Inspection	Machine Type	
1	General condition (first impression)	- Visual control, condition	All
2	Machine tightness	- Visual control, become less crowded	All
3	Fill hose, fill valve & air gap system	- condition and function	All
4	Water level wash tank, air chamber	- Condition & function due to visual control - Check soil level inside air chamber	AMX/AM900
5	Pressure transmitter, pressure hose	- Check soil level inside air chamber - Condition & function due to visual control - Check sealing of pressure hose	All
6	Booster, rinse pump, rinse manifold	- Condition & function due to visual control - Tightness - Check Booster water level using routine S56 (Service manual)	AMX/AM900
7	Wash & rinse arms	- Check wash & rinse arm spinning - Removing & cleaning of upper and lower rinse and wash arms - Visual inspection of abrasion and lime deposits of wash & rinse arms, replace it when necessary.	All
8	Wash arm bearing, sliding ring and milled nut	- Visual inspection of abrasion and lime deposits of wash arm bearing sliding ring and milled nut, replace it when necessary. Hxle-wash arm(00-883452-001), milled nut(7159006-6), gasket(00-775933-003).	All
9	Wash arm washer	- Visual inspection of abrasion, warping and deformation of wash arm washer, replace it. Teflon washer(00-774072-001/002, 00-774072-007).	All
10	Safety equipment: hood end switch	- Check function	All
11	Bosster and tank heating elements	- Condition, fuction and tightness	All
12	Door & Hoodlift	- Operating noise (rolls) - Adujstment of the hood in standby position - Visual control, condition, tightness - Function check - Function, check door slide bearing, doorstop damper, replace it when necessary.	AMX/AM900 AM50E/60E
13	Door mechanism clamping force	- Check clamping force	AMX/AM900 AM60E
14	Bow	- Function, check bow bearing	AMX/AM900
15	Tighness of top cover / BAE	- Visual inspection: tightness top cover and BAE - Humidity in BAE, if necessary replace and change seal top cover	AMX/AM900 H(E)502L(P)
16	Machine control unit, contactor, fuses & touch panel	- Check condition and function, if necessary test run	All
17	Control unit & circuit board: _____ number of cycles	- Visual inspection, check moisture penetration	All
18	Detergent & rinse aid dosing	- Check function - Check dosing level	All
19	Detergent & Rinse aid hoses	- Check tightness, especially on interface hose / connection nipple - Exchange all hoses every 2 years	All
20	Chemical sensor for rinse- and detergent agent	- Check switching function	All
21	Drain pump	- Check residual water after drain, if necessary check drain pump (impeller)	All
22	Drain hose	- Visual inspection, exchange by porosity or damaging	All
23	Wash & rinse result	- Performance control	All
24	Softener (if existing)	- Visual inspection, condition, corrosion ect. - Check hardness	All
25	Descale	-Check the deposit of scale in wash tank and booster, descale it promptly.	All
26	If necessary water analysis _____°d (GH); _____°d (KH); _____µS		All
27	Test run		All
28	Wash pump	-Check the leakage of shaft seal. if necessary replace and change shaft seal.	