



DigitalFlow™ XMT868i

Panametrics Ultrasonic Flow Transmitter for Liquids

Startup Guide



GE
Sensing

DigitalFlow™ XMT868i

Panometrics Ultrasonic Flow Transmitter for Liquids

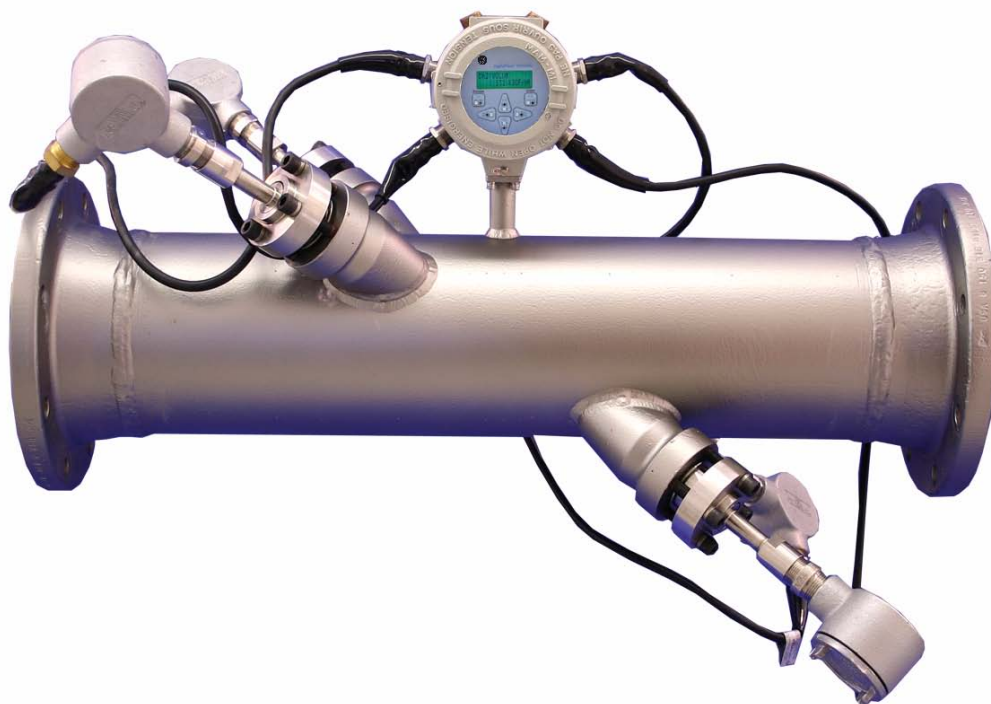

Startup Guide (1 and 2-Channel)

910-171UD

May 2007

DigitalFlow™ is a GE Panometrics product. GE Panometrics has joined other GE high-technology sensing businesses under a new name—GE Sensing.



Warranty

Each instrument manufactured by GE Sensing, Inc. is warranted to be free from defects in material and workmanship. Liability under this warranty is limited to restoring the instrument to normal operation or replacing the instrument, at the sole discretion of GE. Fuses and batteries are specifically excluded from any liability. This warranty is effective from the date of delivery to the original purchaser. If GE determines that the equipment was defective, the warranty period is:

- one year for general electronic failures of the instrument
- one year for mechanical failures of the sensor

If GE determines that the equipment was damaged by misuse, improper installation, the use of unauthorized replacement parts, or operating conditions outside the guidelines specified by GE, the repairs are not covered under this warranty.

The warranties set forth herein are exclusive and are in lieu of all other warranties whether statutory, express or implied (including warranties of merchantability and fitness for a particular purpose, and warranties arising from course of dealing or usage or trade).

Return Policy

If a GE Sensing, Inc. instrument malfunctions within the warranty period, the following procedure must be completed:

1. Notify GE, giving full details of the problem, and provide the model number and serial number of the instrument. If the nature of the problem indicates the need for factory service, GE will issue a RETURN AUTHORIZATION number (RA), and shipping instructions for the return of the instrument to a service center will be provided.
2. If GE instructs you to send your instrument to a service center, it must be shipped prepaid to the authorized repair station indicated in the shipping instructions.
3. Upon receipt, GE will evaluate the instrument to determine the cause of the malfunction.

Then, one of the following courses of action will then be taken:

- If the damage is covered under the terms of the warranty, the instrument will be repaired at no cost to the owner and returned.
- If GE determines that the damage is not covered under the terms of the warranty, or if the warranty has expired, an estimate for the cost of the repairs at standard rates will be provided. Upon receipt of the owner's approval to proceed, the instrument will be repaired and returned.

Table of Contents

Chapter 1: Installation

Introduction	1-1
Unpacking	1-2
Site Considerations	1-2
Electronics Enclosure Location	1-2
Flowcell Location	1-3
Transducer Location	1-3
Cable Lengths	1-3
Transducer Cables	1-3
Installing a Flowcell	1-4
Installing Temperature Transmitters	1-4
Mounting the XMT868i Electronics Enclosure	1-5
Making Electrical Connections	1-6
Wiring the Line Power	1-7
Wiring Transducers	1-9
Wiring Standard 0/4-20 mA Analog Outputs	1-10
Wiring the Serial Port	1-11
Wiring Option Cards	1-13

Chapter 2: Initial Setup

Introduction	2-1
XMT868i Enclosure Infrared Keypad	2-2
Entering Data in the Global Menu	2-4
Entering Global System Data	2-4
Entering Data in the Channel Menu	2-9
Selecting the Channel Measurement Method	2-9
Entering Data in the Channel System Option	2-10
Entering Pipe Parameters	2-14

Chapter 3: Operation

Introduction	3-1
Powering Up	3-2
The LCD Display	3-3
The Optional PanaView Display	3-4
Taking Measurements	3-5
Programming the LCD	3-5
Using the LCD Display	3-8
PanaView Display	3-9
Displaying Multiple Text Windows	3-12
Pausing Measurement	3-12

Table of Contents (cont.)

Chapter 4: Specifications

General	4-1
Electrical	4-2
Additional Options	4-3
Transducer	4-4
Pipe Size and Materials	4-6
Wetted Transducers	4-6
Clamp-on Transducers	4-6
Flowcell	4-7

Appendix A: CE Mark Compliance

Introduction	A-1
Wiring	A-1

Appendix B: Data Records

Available Option Cards	B-1
Option Cards Installed	B-2
Site Data	B-3

Appendix C: Measuring P and L Dimensions

Measuring P and L	C-1
-------------------------	-----

Chapter 1

Installation

- Introduction..... 1-1
- Unpacking 1-2
- Site Considerations 1-2
- Installing a Flowcell..... 1-4
- Installing Temperature Transmitters 1-4
- Mounting the XMT868i Electronics Enclosure 1-5
- Making Electrical Connections 1-6
- Procedure Options 1-20

Introduction

To ensure safe and reliable operation of the Model XMT868i Flowmeter, the system must be installed in accordance with the guidelines established by GE Sensing's engineers. Those guidelines, explained in detail in this chapter, include the following topics:

- Unpacking the Model XMT868i system
- Selecting suitable sites for the electronics enclosure and the flowcell/transducers
- Installing the flowcell/transducers

Note: *See the enclosed Transducer Installation Guide for detailed instructions on transducer installation.*

- Installing optional temperature transmitters
- Installing the electronics enclosure
- Wiring the electronics enclosure

!WARNING!

The Model XMT868i flow transmitter can measure the flow rate of many fluids, some potentially hazardous. The importance of proper safety practices cannot be overemphasized.

Be sure to follow all applicable local safety codes and regulations for installing electrical equipment and working with hazardous fluids or flow conditions. Consult company safety personnel or local safety authorities to verify the safety of any procedure or practice.

!ATTENTION EUROPEAN CUSTOMERS!

To meet CE Mark requirements, all cables must be installed as described in Appendix A, *CE Mark Compliance*.

Unpacking

Carefully remove the electronics enclosure, the transducers, and the cables from the shipping containers. Before discarding any of the packing materials, account for all components and documentation listed on the packing slip. The discarding of an important item along with the packing materials is all too common. If anything is missing or damaged, contact the factory immediately for assistance.

Site Considerations

Because the relative location of the flowcell and the electronics enclosure is important, use the guidelines in this section to plan the XMT868i installation. Figure 1-1 below shows a typical installation.

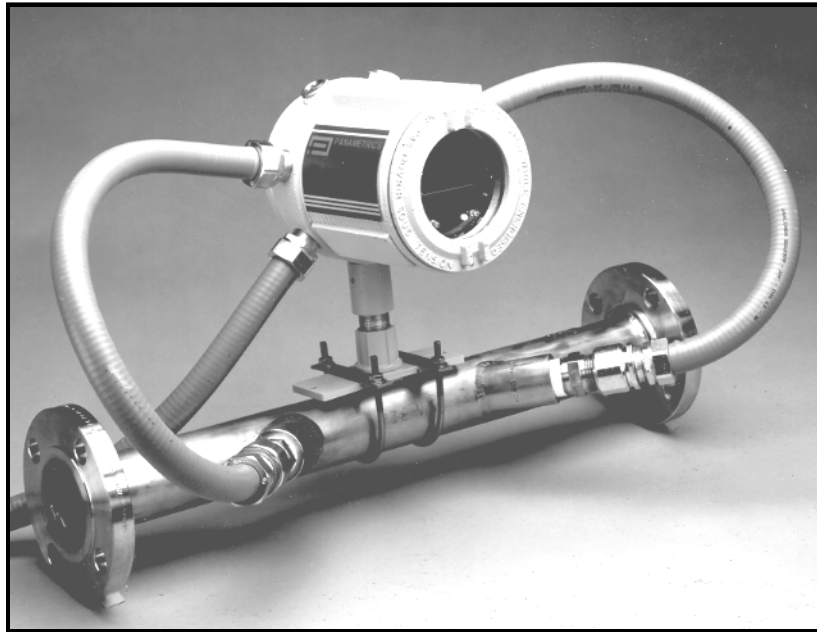

Figure 1-1: A Typical Model XMT868i System

Electronics Enclosure Location

The standard Model XMT868i electronics enclosure is a powder-coated, cast-aluminum, Type-7/4X explosion-proof enclosure, and an optional stainless-steel enclosure is available. Typically, the enclosure is mounted as close as possible to the transducers. When choosing a site, make sure the location permits easy access to the electronics enclosure for programming, maintenance and service.

Note: *For compliance with the European Union's Low Voltage Directive (73/23/EEC), this unit requires an external power disconnect device such as a switch or circuit breaker. The disconnect device must be marked as such, clearly visible, directly accessible, and located within 1.8 m (6 ft) of the Model XMT868i.*

Flowcell Location	Ideally, choose a section of pipe with unlimited access; for example, a long stretch of pipe that is above ground. However, if the flowcell is to be mounted on an underground pipe, dig a pit around the pipe to facilitate installation of the transducers.
Transducer Location	<p>For a given fluid and pipe, the Model XMT868i's accuracy depends primarily on the location and alignment of the transducers. In addition to accessibility, when planning for transducer location, adhere to the following guidelines:</p> <ul style="list-style-type: none">• Locate the transducers so that there are at least 10 pipe diameters of straight, undisturbed flow upstream and 5 pipe diameters of straight, undisturbed flow downstream from the measurement point. Undisturbed flow means avoiding sources of turbulence in the fluid such as valves, flanges, expansions, and elbows; avoiding swirl; and avoiding cavitation.• Locate the transducers on a common axial plane along the pipe. Locate the transducers on the side of the pipe, rather than the top or bottom, since the top of the pipe tends to accumulate gas and the bottom tends to accumulate sediment. Either condition will cause increased attenuation of the ultrasonic signal. There is no similar restriction with vertical pipes. However, vertical pipes should be avoided in order to insure a full pipe at the measurement point.
Cable Lengths	Locate the electronics enclosure as close as possible to the flowcell/transducers, preferably directly on the flowcell. However, GE Sensing can supply transducer cables up to 1,000 ft (300 m) in length for remote location of the electronics enclosure. If longer cables are required, consult the factory for assistance.
Transducer Cables	<p>When installing the transducer cables, always observe established standard practices for the installation of electrical cables. Do not route transducer cables alongside high amperage AC power lines or any other cables that could cause electrical interference. Also, protect the transducer cables and connections from the weather and corrosive atmospheres.</p> <p>Note: <i>If you are using your own cables to connect the transducers to the electronics console, they must have electrical characteristics identical to the cables supplied by GE Sensing. For transducer frequencies up to 2 MHz, the cables in each pair must be the same length within ± 4 in. (10 cm). For transducer frequencies above 2 MHz, the cables in each pair must be the same length within ± 0.5 in. (1.25 cm).</i></p>

Installing a Flowcell

A flowcell is the section of pipe where the transducers are mounted. It can be created either by mounting the transducers on the existing pipeline or by mounting them on a spoolpiece. A spoolpiece is a separately manufactured pipe section, matched to the existing pipe, which contains ports for mounting the transducers. This approach allows the transducers to be aligned and calibrated before inserting the spoolpiece into the pipeline.

Figure 1-1 on page 1-2 shows a typical Model XMT868i spoolpiece, with a mounting bracket to hold the electronics enclosure. For detailed instructions on installing the transducers and/or spoolpiece, refer to the supplied drawings and the enclosed GE Sensing *Liquid Transducer Installation Guide* (916-055).

Installing Temperature Transmitters

Optional temperature transmitters may be installed as part of the flowcell, near the ultrasonic transducer ports. Be sure to observe the siting requirements given earlier in this chapter. These transmitters should send a 0/4-20 mA signal to the Model XMT868i. In turn, the XMT868i must be fitted with a suitable option card to process the signals and to provide the required 24 VDC power to the transmitters. Any desired transmitters or sensors may be used, but they must have an accuracy equal to 0.5% of the reading or better.

Note: *Resistive Thermal Devices (RTDs) are a good choice for measuring the temperature.*

Typically, a 1/2" NPT female threaded port is used to mount the transmitters on the flowcell. If the pipeline is insulated, the coupling may need to be extended to provide convenient access. Of course, other types of mounting ports, including flanged ports, may be used for the transmitters.

Figure 1-2 on page 1-5 shows a typical mounting arrangement for a temperature transmitter. The temperature transmitter should protrude 1/4 to 1/2 way into the pipe.

Installing Temperature Transmitters (cont.)

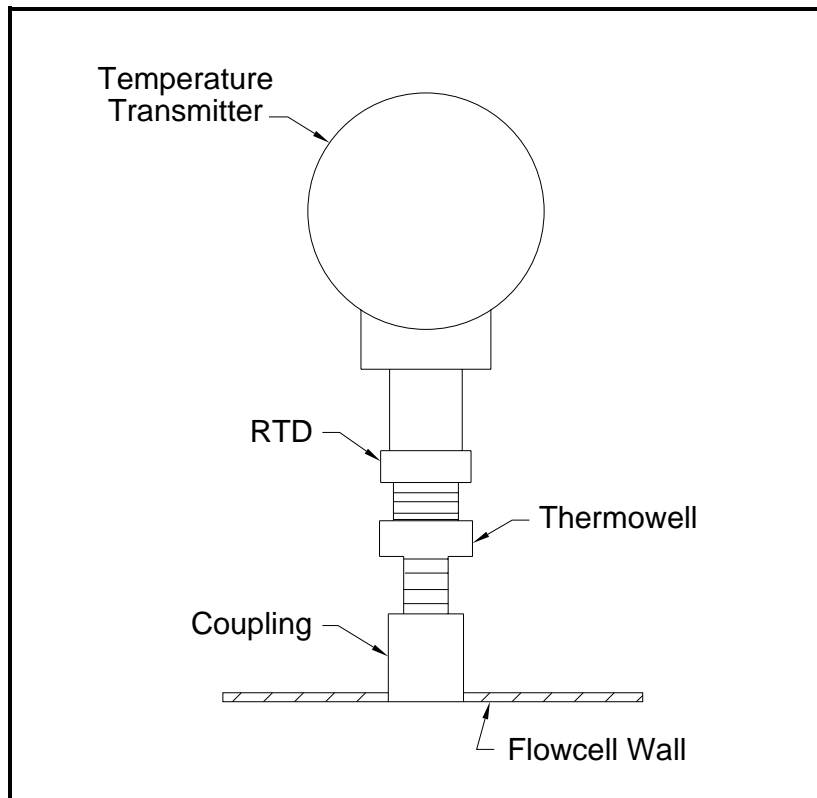

Figure 1-2: Typical Temperature Transmitter Mounting

Mounting the XMT868i Electronics Enclosure

The standard model XMT868i electronics package is housed in a Type-4X weather-resistant enclosure suitable for indoor or outdoor use. Refer to Figure 1-8 on page 1-21 for the mounting dimensions and the weight of this enclosure.

The Model XMT868i electronics enclosure is fitted with a mounting boss that has a single 3/4" NPTF threaded hole at its center and four 1/4-20 tapped holes at its corners. By using this mounting boss, the electronics enclosure may be mounted by any of the typical techniques shown in Figure 1-9 on page 1-22.

!WARNING!

Proper grounding of the XMT868i chassis is required to prevent the possibility of electric shock. See Figure 1-9 on page 1-22 to locate the chassis grounding screw.

IMPORTANT: *Since the IREX keys do not work properly in direct sunlight, be sure to position the XMT868i with an optional sunshield or out of direct sunlight.*

Making Electrical Connections

This section contains instructions for making all the necessary electrical connections to the Model XMT868i flow transmitter. Refer to Figure 1-10 on page 1-23 for a complete wiring diagram.

Except for the power connector, all electrical connectors are stored on their terminal blocks during shipment and may be removed from the enclosure for more convenient wiring. Simply, feed the cables through the conduit holes on the side of the enclosure, attach the wires to the appropriate connectors and plug the connectors back into their terminal blocks.

!ATTENTION EUROPEAN CUSTOMERS!
To meet CE Mark requirements, all cables must be installed as described in Appendix A, *CE Mark Compliance*.

Refer to Figure 1-3 on page 1-7 and prepare the Model XMT868i for wiring by completing the following steps:

!WARNING!
Always disconnect the line power from the Model XMT868i before removing either the front cover or the rear cover. This is especially important in a hazardous environment.

1. Disconnect any previously wired power line from the unit.
2. Loosen the set screw on the rear cover.
3. Place a rod or long screwdriver across the cover in the slots provided, and rotate the cover counterclockwise until it comes free from the enclosure.
4. Install any required cable clamps in the appropriate conduit holes around the side of the enclosure.
5. Note the labels inside the rear cover to assist in wiring the power and option card connections. Also, Figure 1-11 on page 1-24 shows the rear cover option card labels for every available option card configuration.

Proceed to the appropriate section of this chapter to make the desired wiring connections.

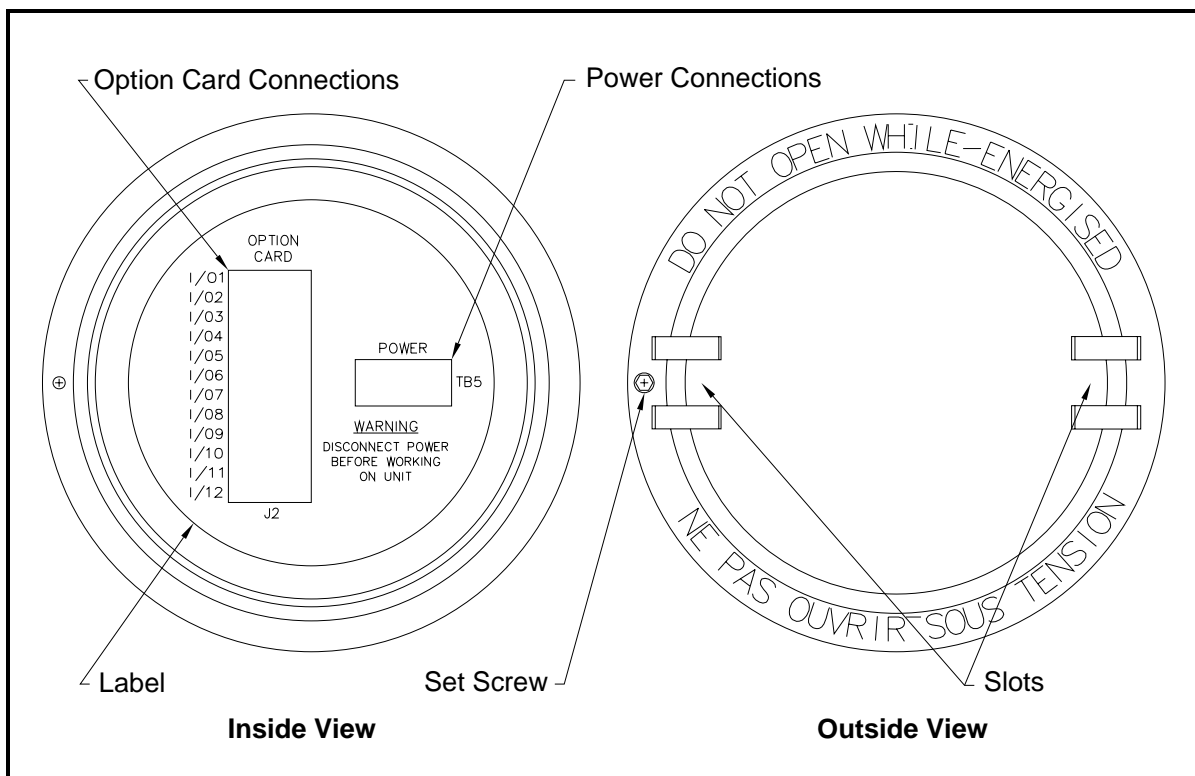

Figure 1-3: Rear Cover with Connection Labels

Wiring the Line Power

The Model XMT868i may be ordered for operation with power inputs of 100-120 VAC, 220-240 VAC, or 12-28 VDC. The label on the side of the electronics enclosure lists the meter's required line voltage and power rating. The fuse size is listed in Chapter 4, *Specifications*. Be sure to connect the meter only to the specified line voltage.

Note: *For compliance with the European Union's Low Voltage Directive (73/23/EEC), this unit requires an external power disconnect device such as a switch or circuit breaker. The disconnect device must be marked as such, clearly visible, directly accessible, and located within 1.8 m (6 ft) of the Model XMT868i.*

Refer to Figure 1-10 on page 1-23 to locate terminal block TB5 and connect the line power as follows:

!WARNING!

Improper connection of the line power leads or connecting the meter to the incorrect line voltage may damage the unit. It may also result in hazardous voltages at the flowcell and associated piping as well as within the electronics enclosure.

Wiring the Line Power
(cont.)

1. Prepare the line power leads by trimming the line and neutral AC power leads (or the positive and negative DC power leads) to a length 0.5 in. (1 cm) shorter than the ground lead. This ensures that the ground lead is the last to detach if the power cable is forcibly disconnected from the meter.
2. Install a suitable cable clamp in the conduit hole indicated in Figure 1-10 on page 1-23. If possible, avoid using the other conduit holes for this purpose, to minimize any interference in the circuitry from the AC power line.

!ATTENTION EUROPEAN CUSTOMERS!
To meet CE Mark requirements, all cables must be installed as described in Appendix A, *CE Mark Compliance*.

3. Strip 1/4-in. of insulation from the end of each of the three line power leads.
4. Route the cable through the conduit hole and connect the line power leads to terminal block TB5, using the pin number assignments shown in Figure 1-10 on page 1-23.
5. Leaving a bit of slack, secure the power line with the cable clamp.

!WARNING!
Make sure both covers, with their O-ring seals, are installed and the set screws tightened before applying power in a hazardous environment.

Caution!
The transducers must be properly wired before applying power to the meter.

Proceed to the next section to continue the initial wiring of the Model XMT868i flow transmitter.

Wiring Transducers

Before wiring the XMT868i transducers, complete the following steps:

- Disconnect the main power from the electronics enclosure.
- Remove the rear cover and install all required cable clamps.

!WARNING!

Before connecting the transducers, take them to a safe area and discharge any static buildup by shorting the center conductor of the transducer cables to the metal shield on the cable connector.

Note: *For transducer frequencies below 2 MHz, the cable lengths must be within 4 in. (10 cm) of each other. If the transducer frequency exceeds 2 MHz, the cable lengths must be within 0.5 in. (1.25 cm) of each other.*

1. Locate the CH1 transducer cables and connect them to the two CH1 transducers in the flowcell. Feed the free ends of the cables through the selected conduit hole in the electronics enclosure.
2. If an optional lightning protector is being installed, connect it between the meter and the transducers.
3. Refer to the wiring diagram in Figure 1-10 on page 1-23 and connect the transducer cables to terminal block J3. Then, secure the cable clamp.

Note: *The RED cable leads are the SIG(+) leads and the BLACK cable leads are the RTN(-) leads.*

!ATTENTION EUROPEAN CUSTOMERS!

To meet CE Mark requirements, all cables must be installed as described in Appendix A, CE Mark Compliance.

4. For a 2-Channel XMT868i, repeat steps 1-2 to connect the CH2 transducers to terminal block J4. It is not required that both channels of a 2-Channel unit be connected.
5. If wiring of the unit has been completed, reinstall the rear cover on the enclosure and tighten the set screw.

Note: *A channel must be activated before it can begin taking measurements. See Chapter 2, Initial Setup, for instructions.*

Wiring Standard 0/4-20 mA Analog Outputs

The standard configuration of the Model XMT868i flow transmitter includes two isolated 0/4-20 mA analog outputs (designated as outputs 1 and 2). Connections to these outputs may be made with standard twisted-pair wiring, but the current loop impedance for these circuits must not exceed 600 ohms.

To wire the analog outputs, complete the following steps:

1. Disconnect the main power to the unit and remove the rear cover.
2. Install the required cable clamp in the chosen conduit hole on the side of the electronics enclosure.
3. Refer to Figure 1-10 on page 1-23 for the location of terminal block J1 and wire the analog outputs as shown. Secure the cable clamp.

Note: *Analog outputs 1 and 2 in the wiring diagram correspond to analog outputs A and B in Slot 0 in the XMT868i software.*

!ATTENTION EUROPEAN CUSTOMERS!

To meet CE Mark requirements, all cables must be installed as described in Appendix A, CE Mark Compliance.

4. If wiring of the unit has been completed, reinstall the rear cover on the enclosure and tighten the set screw.

!WARNING!

Make sure both covers, with their o-ring seals, are installed and the set screws tightened before applying power in a hazardous environment.

Note: *Prior to use, the analog outputs must be set up and calibrated. See Chapter 1, Calibration, of the Service Manual for detailed instructions.*

Proceed to the next section to continue the initial wiring of the unit.

Wiring the Serial Port

The Model XMT868i flow transmitter is equipped with a built-in serial communications port. The standard port is an RS232 interface, but an optional RS485 interface is available upon request. Proceed to the appropriate sub-section for wiring instructions. For more information on serial communications refer to the *EIA-RS Serial Communications* manual (916-054).

Wiring the RS232 Interface

Use the serial port to connect the Model XMT868i flow transmitter to a printer, an ANSI terminal or a personal computer. The RS232 interface is wired as Data Terminal Equipment (DTE), and the signals available at terminal block J1 are shown in Table 1-1 below. Refer to Figure 1-10 on page 1-23 and complete the following steps:

1. Disconnect the main power to the unit and remove the rear cover.
2. Install the required cable clamp in the chosen conduit hole on the side of the electronics enclosure.
3. Use the information in Table 1-1 below to construct a suitable cable for connecting the Model XMT868i to the external device. If desired, an appropriate cable may be purchased from GE Sensing.

Table 1-1: RS232 Connection to DCE or DTE Device

J1 Pin #	Signal Description	DCE DB25 Pin #	DCE DB9 Pin #	DTE DB25 Pin #	DTE DB9 Pin #
5	DTR (Data Terminal Ready)	20	4	20	4
6	CTS (Clear to Send)	4	7	5	8
7	COM (Ground)	7	5	7	5
8	RX (Receive)	2	3	3	2
9	TX (Transmit)	3	2	2	3

Note: *Signal names that imply direction (e.g., transmit and receive) are named from the point of view of the DTE device (the GE Sensing meter is usually considered the DTE device). When the RS232 standard is strictly followed, these signals are labeled with the same name and pin # on the DCE device side as well. Unfortunately, the convention is not followed because the DTE and DCE side get confused. Therefore, connections that imply direction are changed to reflect their direction on the DCE side.*

4. Feed the flying leads end of the cable through the conduit hole and wire it to terminal block J1. Connect the other end of the cable to the printer, ANSI terminal or personal computer, and secure the cable clamp.

*Wiring the RS232 Interface
(cont.)*

!ATTENTION EUROPEAN CUSTOMERS!
To meet CE Mark requirements, all cables must be installed as described in Appendix A, *CE Mark Compliance*.

After the wiring has been completed, consult the *User's Manual* for the external device to configure it for use with the XMT868i.

Wiring the RS485 Interface

Use the optional RS485 serial port to network multiple XMT868i flow transmitters to a single computer terminal. As an option, the standard RS232 port on the XMT868i may be configured as a two-wire, half-duplex RS485 interface.

IMPORTANT: *The XMT868i must be configured at the factory for RS485 operation. The maximum cable length for RS485 is 4000 ft (1200 m).*

To wire the RS485 serial port, refer to Figure 1-10 on page 1-23 and complete the following steps:

1. Disconnect the main power to the unit and remove the rear cover.
2. Install the required cable clamp in the chosen conduit hole on the side of the electronics enclosure.
3. Feed one end of the cable through the conduit hole, wire it to terminal block J1 and secure the cable clamp. Use the information in Table 1-2 below to wire a suitable cable for connecting the XMT868i to the external device.

Table 1-2: RS485 Connections

J1 Pin #	Signal Description
9	Data +
8	Data -
7	Shield
6	Not Used
5	Not Used
4	Not Used

!ATTENTION EUROPEAN CUSTOMERS!
To meet CE Mark requirements, all cables must be installed as described in Appendix A, *CE Mark Compliance*.

4. If wiring of the unit has been completed, reinstall the rear cover on the enclosure and tighten the set screw.

Proceed to the next section to continue the initial wiring of the unit.

Wiring Option Cards

The XMT868i can accommodate one option card in Slot 1 and one option card in Slot 2. The following types of option cards are available only in the combinations listed in Table B-1 on page B-1:

- Alarm Relays (Slot 1)
- Analog Inputs (Slot 1)
- Totalizer/Frequency Outputs (Slot 1)
- RTD Inputs (Slot 1)
- Analog Outputs (Slot 1)
- MODBUS Communications (Slot 2)
- MODBUS/TCP Communications (Slot 2)
- Ethernet (Slot 2)
- Foundation Fieldbus (Slot 2)
- Data logging (Slot 2) - *no wiring required*

Preparing for Wiring

Wiring any option card installed in Slot 1 requires completion of the following general steps:

1. Disconnect the main power to the unit and remove the rear cover.
2. Install a cable clamp in the chosen conduit hole on the side of the electronics enclosure and feed a standard twisted-pair cable through this conduit hole.
3. Locate the 12-pin terminal block (J2) in Figure 1-10 on page 1-23 and wire the option card as indicated on the label inside the rear cover (see Figure 1-3 on page 1-7 and Figure 1-11 on page 1-24). Secure the cable clamp.

IMPORTANT: *Because of the attached wiring label, all rear covers must remain with their original meters.*

!ATTENTION EUROPEAN CUSTOMERS!
To meet CE Mark requirements, all cables must be installed as described in Appendix A, CE Mark Compliance.

4. If wiring of the unit has been completed, reinstall the rear cover on the enclosure and tighten the set screw.

Note: *Prior to use, the option card must be set up and calibrated. See Chapter 1, Programming Site Data, in the Programming Manual and Chapter 1, Calibration, in the Service Manual for detailed instructions.*

For more specific instructions on particular option cards, proceed to the appropriate sub-section(s) that follow.

Wiring an Alarms Option Card

Each alarms option card includes two or four general-purpose *Form C* relays (designated as A, B, C and D).

The maximum electrical ratings for the relays are listed in Chapter 4, *Specifications*. Each of the alarm relays can be wired as either *Normally Open* (NO) or *Normally Closed* (NC).

In setting up an alarm relay, it may be wired for either *conventional* or *fail-safe* operation. In fail-safe mode, the alarm relay is constantly energized, except when it is triggered or a power failure or other interruption occurs. See Figure 1-4 below for the operation of a normally open alarm relay in both conventional and fail-safe mode.

Connect each alarm relay in accordance with the wiring instructions shown on the label inside the rear cover (see Figure 1-3 on page 1-7 and Figure 1-11 on page 1-24).

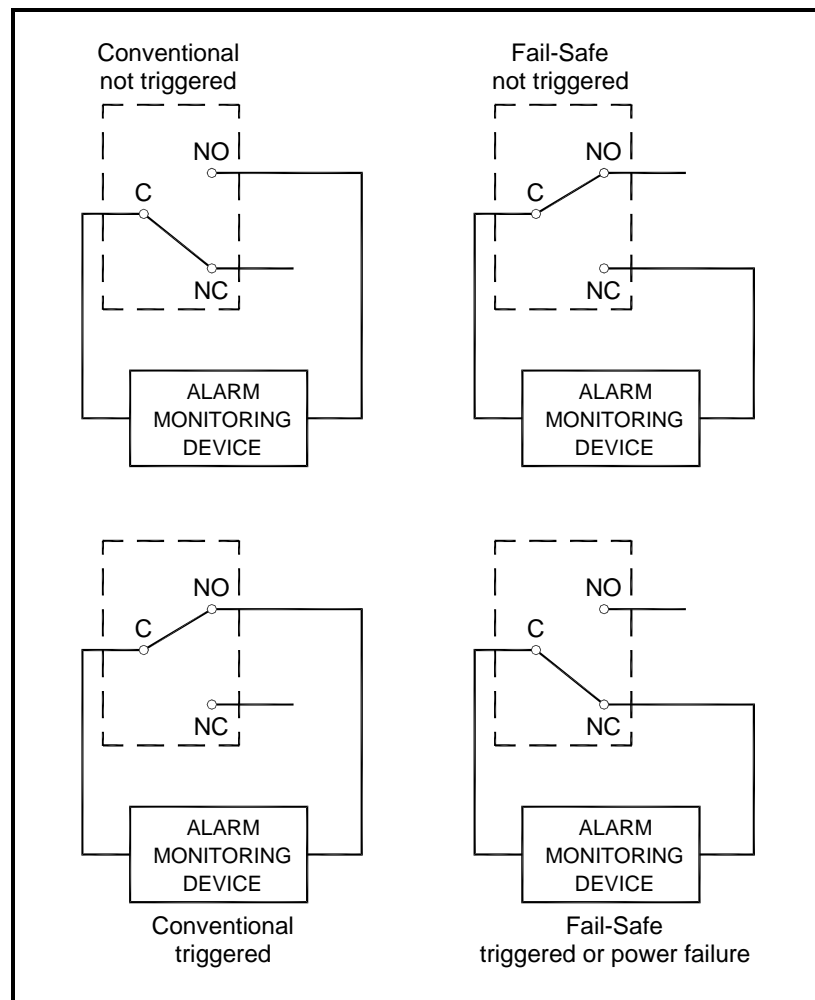

Figure 1-4: Conventional and Fail-Safe Operation

*Wiring a 0/4-20 mA
Analog Inputs Option Card*

This option card includes two or four isolated 0/4-20 mA analog inputs (designated as A, B, C and D), each of which includes a 24 VDC power supply for loop-powered transmitters. Either input may be used to process the temperature signal, while the other input is used to process the pressure signal.

Note: *To enter programming data during operation of the meter, it will be necessary to know which input is assigned to which process parameter. This information should be entered in Appendix B, Data Records.*

The analog inputs, which have an impedance of 118 ohms, should be connected with standard twisted-pair wiring. Power to the transmitters may be supplied either by the integral 24 VDC power supply on the analog input option card or by an external power supply. Figure 1-5 below shows typical wiring diagrams, with and without an external power supply, for one of the analog inputs.

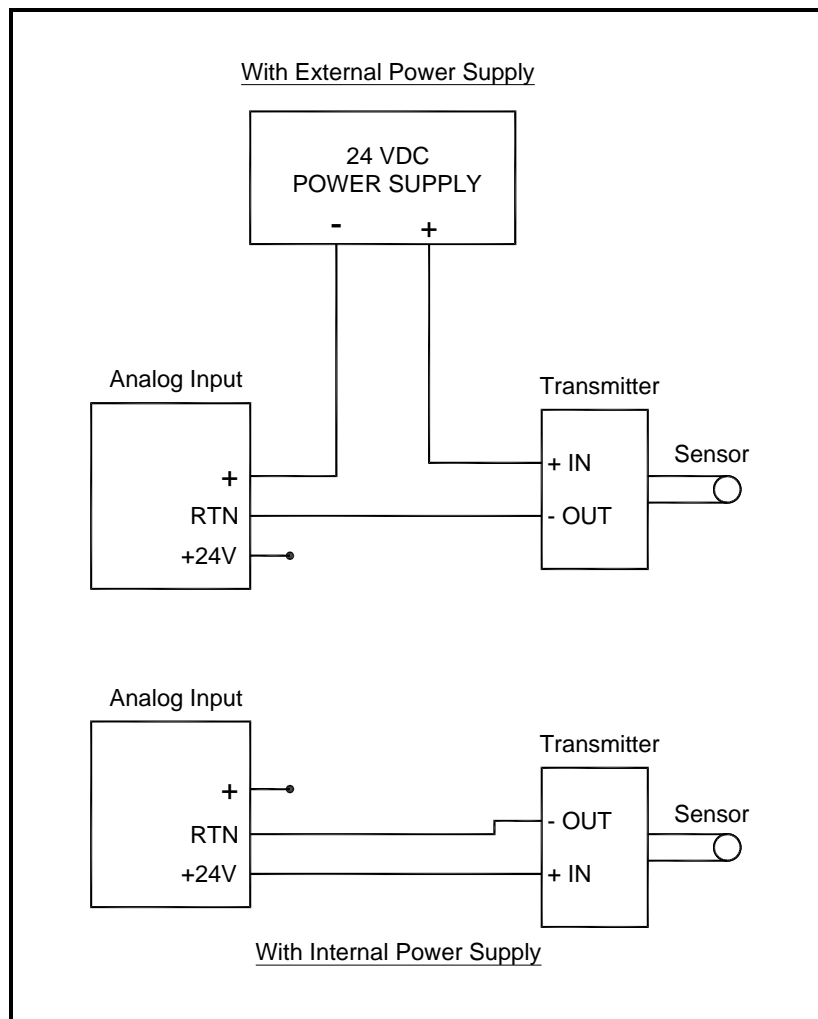

Figure 1-5: Analog Input Wiring Diagram

*Wiring a 0/4-20 mA
Analog Inputs Option Card
(cont.)*

Wire the analog inputs as shown on the label in the rear cover (see Figure 1-3 on page 1-7 and Figure 1-11 on page 1-24).

Note: *The analog inputs option card can be calibrated with the Model XMT868i's built-in analog outputs. However, be certain that the analog outputs have been calibrated first. See Chapter 1, Calibration, in the Service Manual for the appropriate procedures.*

*Wiring a Totalizer and
Frequency Output Option
Card*

Each totalizer and frequency output option card provides two or four outputs (designated as A, B, C, and D).

Wire this option card in accordance with the connections shown on the label in the rear cover (see Figure 1-3 on page 1-7 and Figure 1-11 on page 1-24). Figure 1-6 below shows sample wiring diagrams of a totalizer output circuit and a frequency output circuit. Refer to *Electrical Specifications* on page 4-2 for the load and voltage requirements.

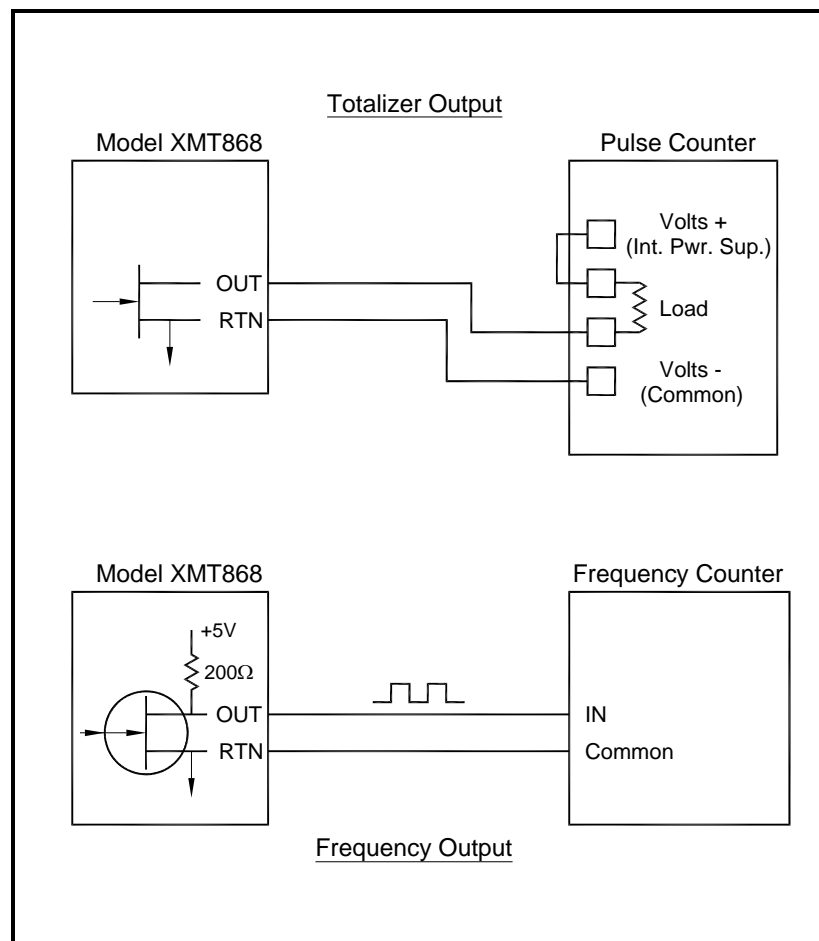

Figure 1-6: Totalizer and Frequency Output Wiring

Wiring an RTD Inputs Option Card

The Model XMT868i RTD (Resistance Temperature Device) inputs option card provides two direct RTD inputs (designated as A and B). Each RTD input requires three wires, and should be connected as shown on the label in the rear cover (see Figure 1-3 on page 1-7 and Figure 1-11 on page 1-24).

Wiring a 0/4-20 mA Analog Outputs Option Card

The analog outputs option card includes two isolated 0/4-20 mA outputs (designated as A and B). Connections to these outputs may be made with standard twisted-pair wiring, but the total current loop impedance for these circuits must not exceed 1,000 ohms. Wire this option card with the connections shown on the label in the rear cover (see Figure 1-3 on page 1-7 and Figure 1-11 on page 1-24).

A Specific Example

To illustrate the procedures described in the previous sections for wiring the option cards, a specific example may prove helpful. Assume that an XMT868i is equipped with an option card numbered 703-1223-08. Table B-1 on page B-1 in Appendix B, *Data Records*, indicates that this option card includes two analog current inputs and two standard alarm relays.

By referring to Figure 1-11 on page 1-24, you can see that the appropriate connection diagram for this option card is the first one from the left in the middle row. This label should also be found inside the rear cover of the XMT868i. Based on this information, wiring of the Input/Output connections to terminal block J2 should be completed as shown in Table 1-3 below.

Table 1-3: Wiring a 703-1223-08 Option Card

J2 Pin #	Description	Connection
1	Alarm A	Normally Open
2	Alarm A	Common
3	Alarm A	Normally Closed
4	Alarm B	Normally Open
5	Alarm B	Common
6	Alarm B	Normally Closed
7	Out C	+24 V to Input C
8	Input C	Signal (+)
9	Input C	Return (-)
10	Out D	+24 V to Input D
11	Input D	Signal (+)
12	Input D	Return (-)

Wiring the MODBUS Option Card

The MODBUS option card uses the RS485 standard for MODBUS communication. The MODBUS card must be installed in Slot 2. The RS485 standard allows up to 32 nodes (drivers and receivers) on one multidrop network, at distances up to 4,000 ft (1,200 m). GE Sensing recommends using 24-gauge (24 AWG) twisted-pair wire with a characteristic impedance of 120 ohms and 120-ohm termination at each end of the communications line.

Note: *The MODBUS option card provides its own RS485 connections. Thus, the meter can have its serial port configured as RS232 and still provide RS485 MODBUS signals.*

IMPORTANT: *Because the MODBUS option card uses pins 1 and 2 on terminal block J2, only those option cards that do not use these pins may be installed in Slot 1, while a MODBUS card is installed in Slot 2. Specifically, only the option cards designated as “OI” and “OR” in Figure 1-11 on page 1-24 are compatible with the MODBUS option card.*

To link the XMT868i to the control system (refer to Figure 1-7):

1. Connect the TMT- wire to pin #2, the inverting or negative connection.
2. Connect the TMT+ wire to pin #1, the non-inverting or positive connection.
3. If desired, the pin #3 can be used for an optional shield.

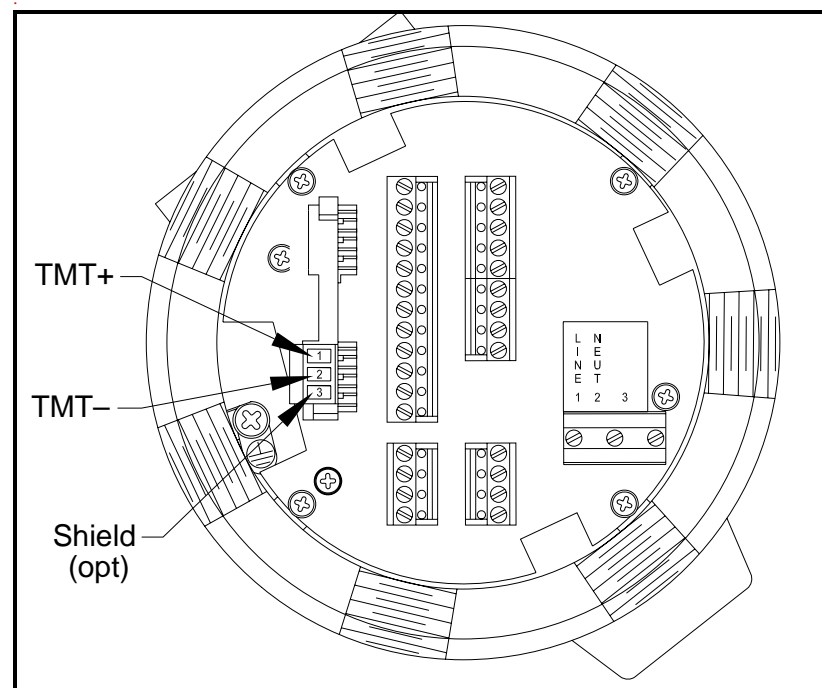

Figure 1-7: The RS485 MODBUS Terminal Block Connector

Wiring the MODBUS/TCP Interface

Customers can also use a modified XMT868i that provides a MODBUS/TCP interface to communicate to an internal network. An optional MODBUS/TCP card with a unique MAC (IP) address (installed only in slot 2) includes an RJ45 connector. To connect the MODBUS/TCP-enabled XMT868i to the network, insert the jack of an RJ45 cable into the RJ45 connector, route the cable through one of the conduit holes using an appropriate cable clamp, and wire the other end of the cable to the Ethernet network according to the manufacturer's instructions. See Figure 1-12 on page 1-25.

Note: *The MAC address for a specific XMT868i is included with customer documentation. For more information on setting up the MAC address, refer to Chapter 6 of the Programming Manual.*

Wiring the Ethernet Interface

A modified XMT868i can use the Ethernet interface to communicate to a local area network. An optional Ethernet card with a unique MAC (IP) address (installed only in slot 2) includes an RJ45 connector. To connect the Ethernet-enabled XMT868i to the network, insert the jack of an RJ45 cable into the RJ45 connector, route the cable through one of the conduit holes using an appropriate cable clamp, and wire the other end of the cable to the Ethernet network according to the manufacturer's instructions. An external connection is required between the Ethernet option card and the XMT868i's RS232 connector, as shown in Table 1-4 below and Figure 1-12 on page 1-25.

Note: *The MAC address for a specific XMT868i is included with customer documentation. For more information on setting up the MAC address, refer to Appendix C of the Programming Manual.*

Table 1-4: RS232 to Ethernet Interconnections

XMT868i Type	Terminal Block	Terminal Block
Terminal	RS232 on Rear Board	TB1 on Ethernet Card
	TX	Pin 1
	RX	Pin 2
	COM	Pin 3

*Wiring the Foundation
Fieldbus Interface*

To connect the Foundation Fieldbus interface to the XMT868i, make the network connections at J8, pins 1 and 2, as shown in drawing Y of Figure 1-12 on page 1-25. As an option, you can connect a shield to J8 pin 3, depending on the network wiring.

No connections are made to J9 under normal operation. If you need to reset the network board to factory defaults:

1. Connect a jumper between J9 pin 2 and J9 pin 3.
2. Power cycle (i.e., turn off and on) the XMT868i.
3. Ten seconds after the power has been restored to the XMT868i, remove the jumper to return the network board to normal operation.

Data Logging Option Card

The XMT868i can be fitted with a data logging option card, which must be installed in Slot 2. The data logging option card increases the XMT868i's memory by up to 2 MB.

!ATTENTION EUROPEAN CUSTOMERS!
**To meet CE Mark requirements, all cables must be
installed as described in Appendix A, *CE Mark
Compliance*.**

Procedure Options

After the XMT868i has been completely installed and wired, proceed to Chapter 2, *Initial Setup*, to program the meter for taking flow rate measurements.

!WARNING!
**Make sure both covers, with their o-ring seals, are
installed and the set screws tightened before applying
power in a hazardous environment.**

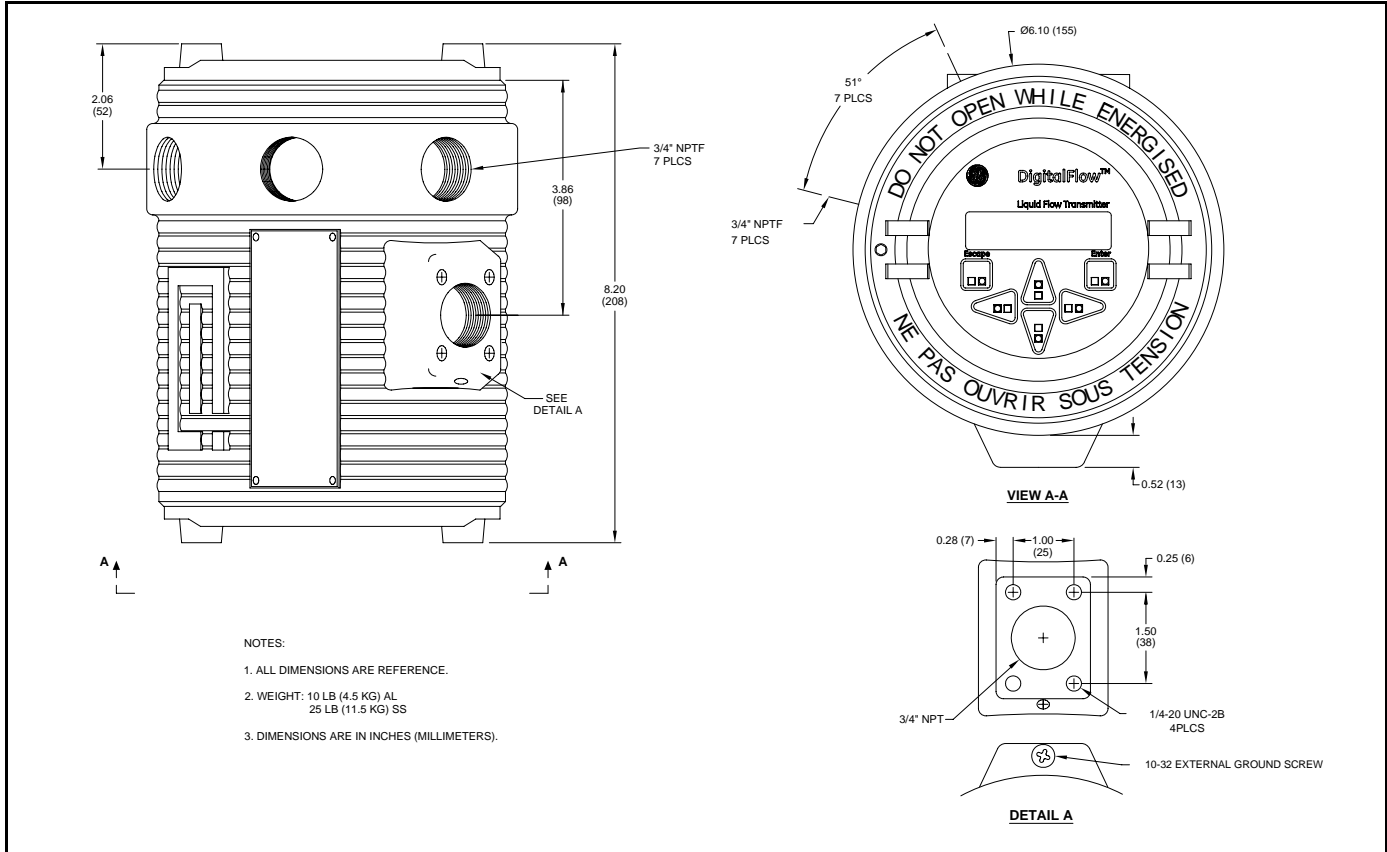

Figure 1-8: Model XMT868 Outline and Installation (ref. dwg #712-1318)

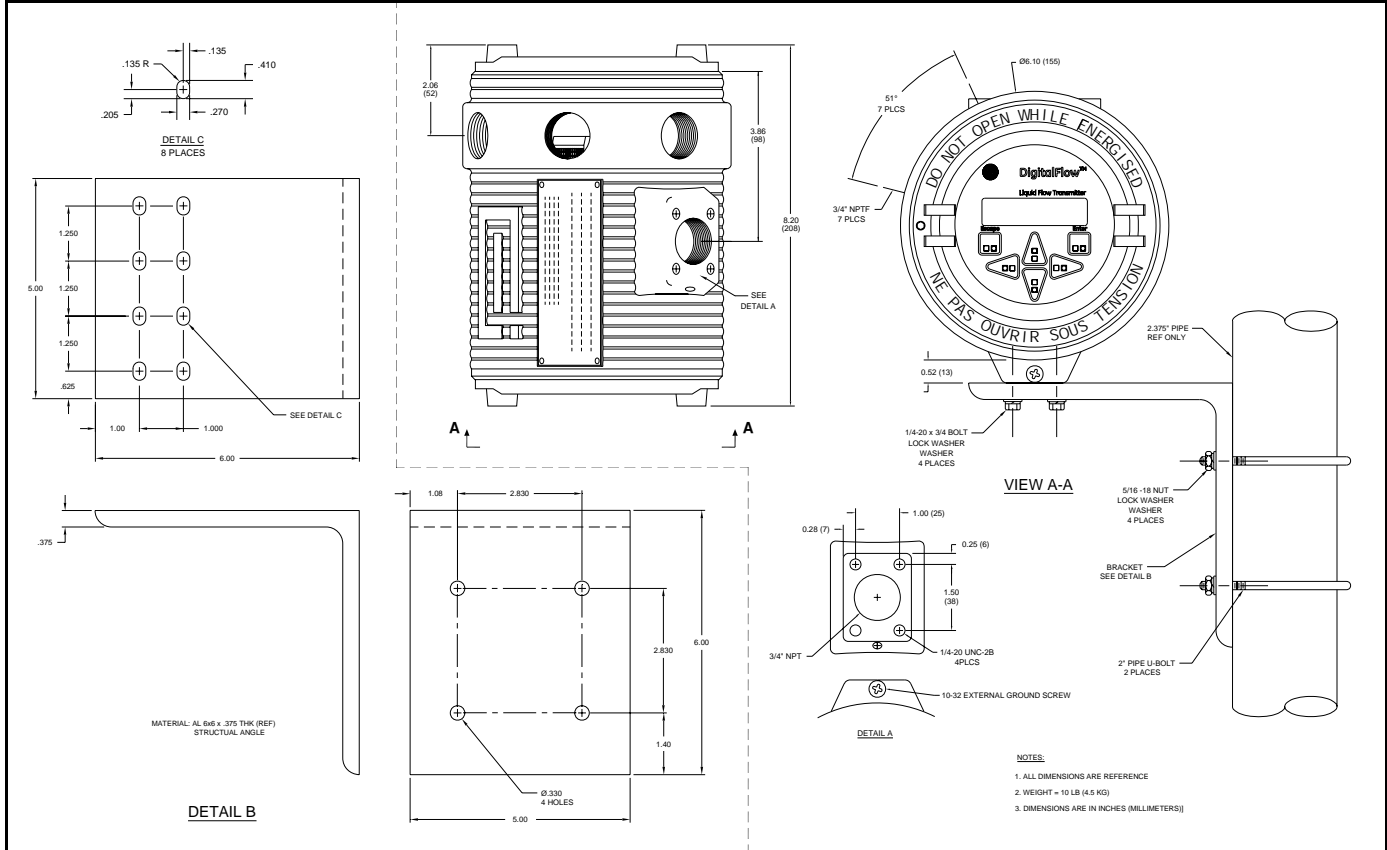

Figure 1-9: Model XMT868: Outline and Installation - Right Angle Mounting Bracket (ref. dwg #7112-1317)

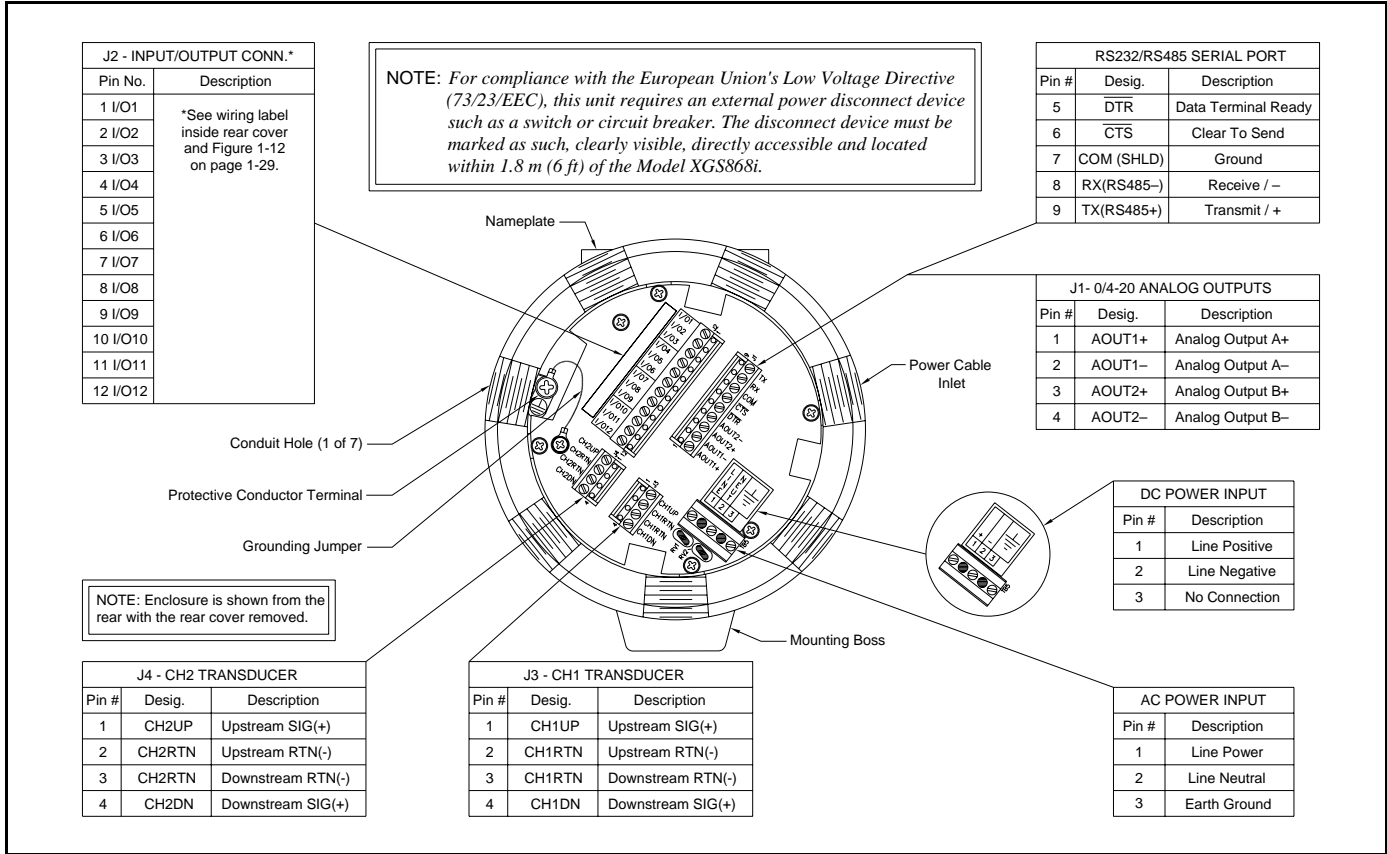
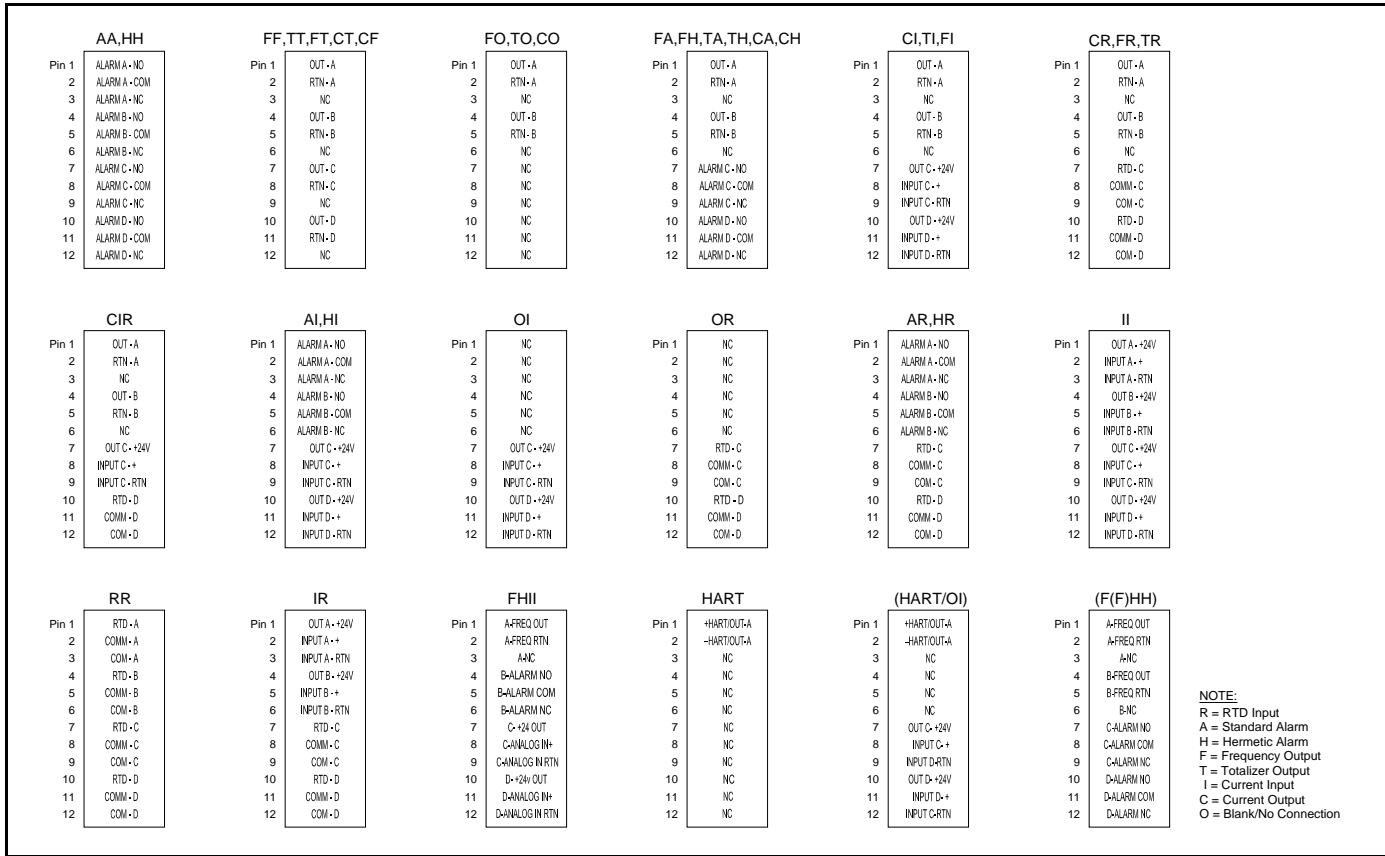

Figure 1-10: Model XMT868i Wiring Diagram



NOTE:
 R = RTD Input
 A = Standard Alarm
 H = Hermetic Alarm
 F = Frequency Output
 T = Totalizer Output
 I = Current Input
 C = Current Output
 O = Blank/No Connection

Figure 1-11: Option Card Connection Labels (ref. dwg #442-615)

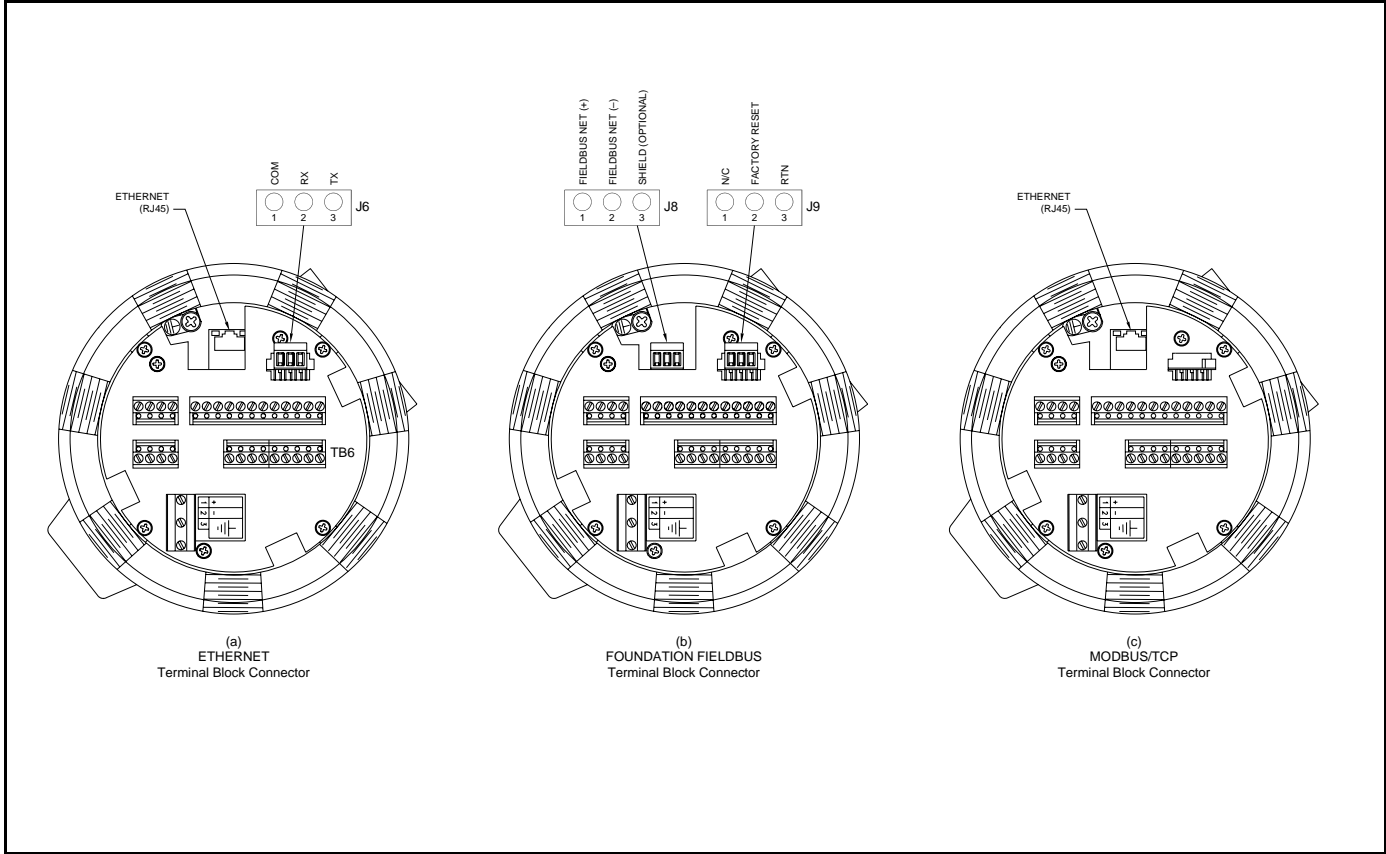

Figure 1-12. Ethernet, Foundation Fieldbus and MODBUS/TCP Terminal Block Connections

Chapter 2

Initial Setup

Introduction.....	2-1
XMT868i Enclosure Infrared Keypad	2-2
Entering Data in the Global Menu	2-4
Entering Data in the Channel Menu.....	2-9

Introduction

This chapter provides instructions for programming the minimum amount of data required to place the Model XMT868i flowmeter into operation. Before the Model XMT868i can begin taking measurements and displaying valid data, the current system and pipe parameters must be entered. In addition, a 2-Channel meter requires that each channel be activated prior to use. Additional programming options provide access to the more advanced features of the Model XMT868i, but this information is not required to begin taking measurements.

Note: *See the Programming Manual for information on those User Program features not covered in this chapter.*

You can program the XMT868i via either the infrared keypad on the lower part of the glass enclosure, or **PanaView™**, a PC-based, non-resident software program that communicates with the XMT868i via its RS232 serial port. PanaView supplements basic XMT868i functions with several additional capabilities. With PanaView, you can:

- load and save site file data
- create and save graph and log files
- display text output and graphs of live measurement data
- create custom templates for displaying text, graph and log data
- interface with multiple GE Sensing instruments.

This chapter focuses on programming via the infrared keypad. For information on programming the XMT868i via PanaView, refer to Appendix C of the *Programming Manual*.

XMT868i Enclosure Infrared Keypad

The window at the top of the XMT868i enclosure includes the components shown in Figure 2-1 below.

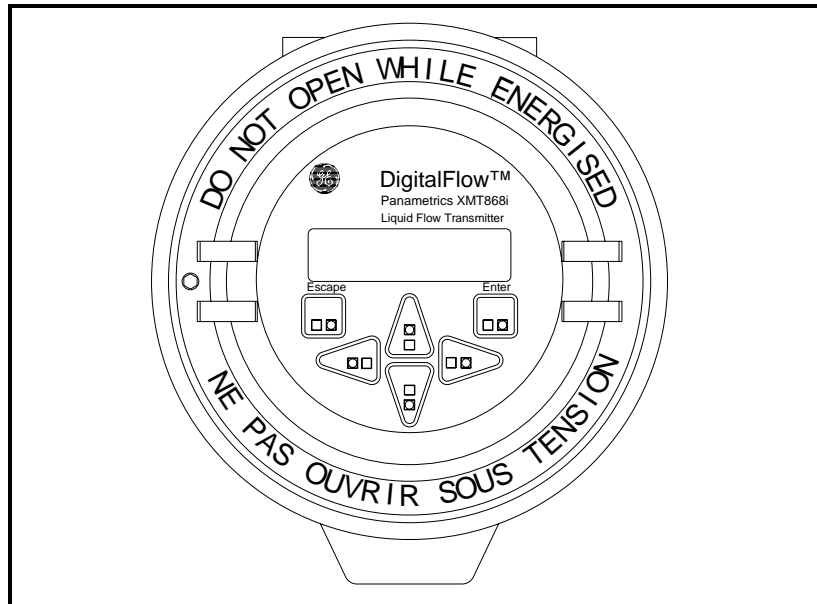

Figure 2-1: The Enclosure Window

IMPORTANT: *The XMT868i's infrared keypad permits programming of the instrument through the glass faceplate without removing the cover. Thus, all programming procedures may be performed while the unit is installed in a hazardous area.*

Six keys on the infrared keypad enable users to program the XMT868i:

- [Enter] - confirms choice of a specific option and data entry within the option
- [Escape] - allows users to exit from a specific option without entering unconfirmed data
- [△] and [▽] - enable users to highlight a specific window in the display option or to scroll through a list of options (parameters, letters, and numbers 0-9 as well as the negative sign and decimal point) in a menu
- [◀] and [▶] - enable users to scroll to a specific option, among choices in an option, or to a character in a text entry.

When you power up the XMT868i, the display first shows the model and software version:

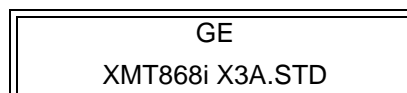

XMT868i Enclosure Infrared Keypad (cont.)

The meter then starts to display measured parameters.

CH1	VEL	E1
10.00		Ft/s

To enter the *Keypad Program*, press the [Escape] key, followed by the [Enter] key, and the [Escape] key again. Each successive key must be entered within 10 seconds of the prior key.

As a guide in following the programming instructions in this chapter, the relevant portions of the Model XMT868i menu map have been reproduced in Figures 2-2 and 2-3 on pages 2-20 and 2-21. Proceed to the following sections to enter data in the Channel or GLOBL menus.

IMPORTANT: *If the keypad has not been pressed for 10 minutes, the XMT868i exits the Keypad Program and returns to displaying measurements. The meter retains any configuration changes that were confirmed with the [Enter] key, and restarts as if the operator had completed the programming cycle.*

Entering Data in the Global Menu

To begin programming your meter, you must select the system units from the GLOBL menu as discussed below. Refer to Figure 2-2 on page 2-20 and remember to record all programming data in Appendix B, *Data Records*.

Note: Refer to the Programming Manual for information on the other submenus in the GLOBL menu.

Entering Global System Data

The GLOBL-SYSTEM submenu is used to enter several general system parameters (e.g., English or metric units). For units with 2 channels, this menu is also used to compute parameters such as the sum, difference or average of the channel 1 and channel 2 signals. When calculating the SUM, DIF or AVE readouts, data from the GLOBL-SYSTEM submenu is used. Any conflicting data entered in the Channel System submenu is overridden.

1. In the *Keypad Program*, scroll to PROG and press [Enter].
2. In the PROG menu, scroll to GLOBL and press [Enter].
3. In the Global PROGRAM menu, scroll to SYSTEM and press [Enter].
4. The first prompt asks for a *Meter Message*. Enter a numeric or text message (up to 16 characters) and press [Enter].
5. Scroll to the desired *System Units* selection (either metric or English) and press [Enter]. The XMT868i will display all parameters and measurements in the designated units.
 - For a single-channel XMT868i, the program returns to the Global PROGRAM menu. Scroll to CH1 or CH2 to enter the Channel menu discussed on page 2-9.
 - For a 2-channel meter, proceed to step 6.

Volumetric Units

6. Scroll to the desired *Volumetric Units* for the flow rate display and press [Enter]. Table 2-1 below lists the available volumetric units.

Table 2-1: Available Volumetric Units

English	Metric
GAL/S = gallons/second	L/S = Liter/sec
GAL/M = gallons/minute	L/M = Liter/min
GAL/H = gallons/hour	L/H = Liter/hr
MGD = mega gallons/day	ML/D = mega liters/day
ft ³ /s = Cubic ft/sec	m ³ /s = Cubic m/sec
ft ³ /m = Cubic ft/min	m ³ /m = Cubic m/min
ft ³ /h = Cubic ft/hr	m ³ /h = Cubic m/hr
ft ³ /d = Cubic ft/day	m ³ /d = Cubic m/day
Mft ³ /d = mega cubic feet/day	Mm ³ /d = mega cubic meters/day
BBL/S = Barrel/sec	BBL/S = Barrel/sec
BBL/M = Barrel/min	BBL/M = Barrel/min
BBL/H = Barrel/hr	BBL/H = Barrel/hr
BBL/D = Barrel/day	BBL/D = Barrel/day
MBL/D = mega barrels/day	MBL/D = mega barrels/day
A-I/S = Acre-inch/sec	
A-I/M = Acre-inch/min	
A-I/H = Acre-inch/hr	
A-I/D = Acre-inch/day	
A-F/S = Acre-feet/sec	
A-F/M = Acre-feet/min	
A-F/H = Acre-feet/hr	
A-F/D = Acre-feet/day	

7. Scroll to the desired number of *Vol Decimal Digits* (digits to the right of the decimal point) in the volumetric flow display, and press [Enter].

Totalizer Units

8. Scroll to the desired *Totalizer Units* for the totalized flow rate display (listed in Table 2-2 below), and press [Enter].

Table 2-2: Totalizer Units

English	Metric
GAL = Gallons	L = Liters
MGAL = mega gallons	ML = Megaliters
ft ³ = Cubic feet	m ³ = Cubic meters
Mft ³ = mega cubic feet	Mm ³ = mega cubic meters
BBL = Barrels	BBL = Barrels
MBBL = mega barrels	MBBL = mega barrels
AC-IN = Acre-inches	
AC-FT = Acre-feet	

9. Scroll to the desired number of *Decimal Digits* (digits to the right of the decimal point) in the totalized flow display, and press [Enter].

The program now varies, depending on whether you have activated *Mass Flow* (see the *Programming Manual* for details) or the *Energy Option* in one of the Channel PROGRAM options.

- If you have activated *Mass Flow*, continue to step 1 on the next page.
- If you have activated the *Energy Option* (but not *Mass Flow*), skip to step 1 on page 2-8.
- If you have activated neither option, the XMT868i returns to the Global PROGRAM window. Press [Escape] to return to the PROG menu. Then scroll to CH1 or CH2 and press [Enter] to program the Channel menu.

Programming Mass Flow Data

1. Scroll to the desired *Mass Flow Units* for flow rate display (listed in Table 2-3 below), and press [Enter].

Table 2-3: Available Mass Flow Units

English	Metric
LB = Pounds	KG = Kilograms
KLB = KiloPounds (Thousands of Pounds)	Tonne = Metric Tons (1000 KG)
MMLB = MegaPounds	
TONS (2000 LB)	

2. Scroll to the desired *Mass Flow Time Units* (from seconds to days), and press [Enter].
3. Scroll to the desired number of *Decimal Digits* (digits to the right of the decimal point) in the mass flow rate display, and press [Enter].
4. Scroll to the desired *Mass Totals* (units for the totalized mass flow rate display, listed in Table 2-3 above), and press [Enter].
5. Scroll to the desired number of *Mass Decimal Digits* (digits to the right of the decimal point) in the totalized mass flow rate display, and press [Enter].

The program varies, depending on whether or not you have enabled the *Energy Option*.

- If you have not enabled the option, the XMT868i returns to the Global PROGRAM window. Press [Escape] to return to the PROG menu and scroll to the Channel PROGRAM.
- If you have enabled the option, continue to the next page.

Programming the Energy Option

1. Scroll to the desired *Power Units* (listed in Table 2-4 below) and press [Enter].

Table 2-4: Available Power Units

English	Metric
kBTUh = Thousands of BTUs/hour	kCALs = Kilocalories/second
MMBTU = Millions of BTUs/hour	kCALm = Kilocalories/minute
kW = Kilowatt	kCALh = Kilocalories/hour
TONS = Tons of refrigerant	kCALd = Kilocalories/day
	MCals = Megacalories/second
	MCALm = Megacalories/minute
	MCALh = Megacalories/hour
	MCALd = Megacalories/day
	kW = Kilowatt
	MW = Megawatt

2. Scroll to the desired number of *Power Decimal Digits*, and press [Enter].
3. Scroll to the desired *Total Energy Units* (shown in Table 2-5 below), and press [Enter].

Table 2-5: Available Total Energy Units

English	Metric
kBTU = Thousands of BTUs	kCAL = Kilocalories
MMBTU = Millions of BTUs	MCAL = Megacalories
kWHR = Kilowatt-hour	kWHr = Kilowatt-hour
TONS = Tons (of refrigerant)	MWHr = Megawatt-hour

4. Scroll to the desired number of *Energy Decimal Digits*, and press [Enter].

You have completed entering selections in this option. The program returns to the Global PROGRAM menu. Scroll to CH1 or CH2 and press [Enter] to program the Channel menu on the next page.

Entering Data in the Channel Menu

The Channel menu is used to enter data specific to each channel. Refer to Figure 2-2 on page 2-20 and remember to record all programming data in Appendix B, *Data Records*.

Note: *In this manual, only the programming of Channel 1 will be described. To program Channel 2 of a 2-Channel meter, simply repeat the same procedures presented for Channel 1.*

Selecting the Channel Measurement Method

The ACTIV submenu permits selection of the desired measurement method.

1. In the *Keypad Program*, scroll to PROG and press [Enter].
2. In the PROG menu, scroll to the desired channel (CH1 or CH2) and press [Enter].

Note: *In the 1-Channel XMT868i, CH2 does not appear.*

3. In the Channel PROGRAM menu, scroll to ACTIV and press [Enter].
4. The option offers two choices: OFF and TRANS (Transit-Time). Scroll to the desired option for this channel and press [Enter].

Note: *In the 1-Channel XMT868i, OFF does not appear.*

The XMT868i returns to the Channel PROGRAM menu. Scroll to the SYSTM option.

Entering Data in the Channel System Option

1. From the Channel PROGRAM menu, scroll to the SYSTM option and press [Enter].
2. The first prompt asks for the *Channel Label*. Use the four scrolling keys to enter the desired label (in any numeric or text combination up to three characters) in the right pane, and press [Enter].
3. The next prompt asks for the *Channel Message*. Enter the desired text in the same manner as the channel label, and press [Enter].
4. The program now asks if you want the *Energy Option*, which enables flow measurement in a heating or cooling system. Scroll to *Off* or *On*, and press [Enter].
5. The next prompt asks for the *Volumetric Units*. Scroll through the available units (from the list shown in Table 2-6 below) and press [Enter] when you reach the desired unit.

Note: Refer to the SYSTM option of the GLOBL menu to choose between English and metric measurements.

Table 2-6: Available Volumetric Units

English Volumetric Units	Metric Volumetric Units
GAL/S - U.S. Gallons per Second	L/S = Liters per Second
GAL/M - U.S. Gallons per Minute	L/M = Liters per Minute
GAL/H - U.S. Gallons per Hour	L/H = Liters per Hour
MGD - Mega U.S. Gallons per Day	ML/D = MegaLiters per Day
ft ³ /s - Cubic Feet per Second	m ³ /s = Cubic Meters per Second
ft ³ /m - Cubic Feet per Minute	m ³ /m = Cubic Meters per Minute
ft ³ /h - Cubic Feet per Hour	m ³ /h = Cubic Meters per Hour
ft ³ /d - Cubic Feet per Day	m ³ /d = Cubic Meters per Day
Mf ³ /d - Mega Cubic Feet per Day	Mm ³ /d = Mega Cubic Meters per Day
BBL/S - Barrels per Second	BBL/S = Barrels per Second
BBL/M - Barrels per Minute	BBL/M = Barrels per Minute
BBL/H - Barrels per Hour	BBL/H = Barrels per Hour
BBL/D - Barrels per Day	BBL/D = Barrels per Day
MBL/D - Mega Barrels per Day	MBL/D = Mega Barrels per Day
A-I/S - Acre-inches per second	N/A
A-I/M - Acre-inches per minute	N/A
A-I/H - Acre-inches per hour	N/A
A-I/D - Acre-inches per day	N/A
A-F/S - Acre-feet per second	N/A
A-F/M - Acre-feet per minute	N/A
A-F/H - Acre-feet per hour	N/A
A-F/D - Acre-feet per day	N/A

Entering Data in the
Channel System Option
(cont.)

6. Scroll to the desired number of *Vol Decimal Digits* (digits to the right of the decimal point) in the volumetric flow display, and press [Enter].
7. Scroll to the desired *Totalizer Units* for the totalized flow rate display (listed in Table 2-7 below), and press [Enter].

Table 2-7: Totalizer Units

English	Metric
GAL - U.S. Gallons	L - Liters
MGAL - Mega U.S. gallons	ML - Megaliters
ft ³ - Cubic Feet	m ³ - Cubic Meters
Mft ³ - Mega Cubic Feet	Mm ³ - Mega Cubic Meters
BBL - Barrels	BBL - Barrels
MBBL - Megabarrels	MBBL - Megabarrels
AC-IN - Acre-inches	
AC-FT - Acre-feet	

8. Scroll to the desired number of *Decimal Digits* (digits to the right of the decimal point) in the totalized flow rate display, and press [Enter].

The program now varies, depending on whether you have activated *Mass Flow* (see the *Programming Manual* for details) or the *Energy Option*.

- If you have activated *Mass Flow*, continue to step 1 on the next page.
- If you have activated the *Energy Option* (but not *Mass Flow*), skip to step 1 on page 2-13.
- If you have activated neither option, the XMT868i returns to the Channel PROGRAM window. Proceed to the PIPE option.

Programming the Mass Flow Option

1. Scroll to the desired *Mass Flow Units* for flow rate display (listed in Table 2-8 below), and press [Enter].

Table 2-8: Available Mass Flow Units

English	Metric
LB = Pounds	Kilograms
KLB = KiloPounds (Thousands of Pounds)	Tonnes = Metric Tons (1000 KG)
MMLB = MegaPounds	
TONS (2000 LB)	

2. Scroll to the desired *Mass Flow Time Units* (from seconds to days), and press [Enter].
3. Scroll to the desired number of *Decimal Digits* (digits to the right of the decimal point) in the mass flow rate display, and press [Enter].
4. Scroll to the desired *Mass Totals* (units for the totalized mass flow rate display, listed in Table 2-8 above), and press [Enter].
5. Scroll to the desired number of *Mass Decimal Digits* (digits to the right of the decimal point) in the totalized mass flow rate display, and press [Enter].

The program varies, depending on whether or not you have enabled the *Energy Option*.

- If you have not enabled the option, the XMT868i returns to the Channel PROGRAM window. Proceed to the PIPE option.
- If you have enabled the option, continue to the next page.

Programming the Energy Option

1. Scroll to the desired *Power Units* (listed in Table 2-9 below) and press [Enter].

Table 2-9: Available Power Units

English	Metric
kBTUh = Thousands of BTUs/hour	kCALs = Kilocalories/second
MMBTU = Mega BTUs/hour	kCALm = Kilocalories/minute
kW = Kilowatt	kCALh = Kilocalories/hour
TONS = Tons (2000 LB)	kCALd = Kilocalories/day
	MCALs = Megacalories/second
	MCALm = Megacalories/minute
	MCALh = Megacalories/hour
	MCALd = Megacalories/day
	kWATT = Kilowatt
	MWATT - Megawatt

2. Scroll to the desired number of *Power Decimal Digits*, and press [Enter].
3. Scroll to the desired *Total Energy Units* (shown in Table 2-10 below), and press [Enter].

Table 2-10: Available Total Energy Units

English	Metric
kBTU = Thousands of BTUs/hr	kCAL = Kilocalories
MMBTU = Mega BTUs/hour	MCAL = Megacalories
kWHr = Kilowatt-hour	kWHr = Kilowatt-hour
TONS = Tons (2000 LB)	MWHr - Megawatt-hour

4. Scroll to the desired number of *Energy Decimal Digits*, and press [Enter].
5. Scroll to highlight if you are using a *Heating or Cooling System*, and press [Enter].
6. The final prompt asks whether you want to conduct *Flow Measurement* at the point of RTN (Return, where the liquid exits) or of SPPLY (Supply, where the liquid enters). Scroll to the appropriate choice, and press [Enter].

You have completed entering data in the SYSTM option. The meter returns to the Channel PROGRAM menu. Proceed to the next page to enter PIPE parameters.

Entering Pipe Parameters Enter the transducer and pipe parameters via the PIPE submenu. While following the programming instructions, refer to Figure 2-3 on page 2-21.

1. From the Channel PROGRAM menu, scroll to the PIPE option and press [Enter].
2. The first prompt asks for the *Transducer Number*.
 - For a standard transducer, enter the number engraved on the transducer head in the right pane, and press [Enter].
 - If there is no number engraved on the transducer head, press the right arrow key to scroll to the *Special* option, enter an assigned number (from 91 to 99), and press [Enter].

IMPORTANT: *Special transducers, which have no engraved number on the head, are rarely used. Examine the transducer head carefully for a number.*

The menu now varies, depending on your selection in step 2.

- If you entered the number for a standard clamp-on transducer, proceed to the *Pipe Material* prompt in step 4.
- If you entered the number for a standard wetted transducer, proceed to the *Pipe OD* prompt in step 5.
- If you entered the number for a special transducer, proceed to step 3 below.

Special Transducers

Note: *For special transducers, GE Sensing will supply a transducer data sheet with programming information.*

3. For special transducers:
 - a. The program first asks for the *Wedge Type*. Press the appropriate transducer type (Rayleigh clamp-on, shear clamp-on, or wetted).

Note: *GE Sensing will supply the information required for steps b through f with the transducers.*

- b. Press the appropriate *Frequency* (from 500 kHz to 5 MHz).
 - c. Enter the *Time Delay (Tw)* value supplied by GE Sensing and press [Enter].

*Special Transducers
(cont.)*

If you have selected a special wetted transducer, the program now goes to step 5. But if you have selected a clamp-on transducer, three more prompts appear.

- d. Enter the *Wedge Angle* of the transducer (the angle of the ultrasonic transmission, in degrees) and press [Enter].
- e. Enter the *Wedge Temperature* and press [Enter].
- f. Enter the *Wedge Soundspeed* and press [Enter].

Pipe Material

4. Scroll to the appropriate *Pipe Material* from the supplied list. For some materials (shown in Table 2-11 below), the program displays additional selections. At the desired choice, press [Enter].

Table 2-11: Pipe Material Choices

Material	Types
Steel	Carbon Steel Stainless Steel
Iron	Ductile Iron Cast Iron
Copper	no additional selection required
Aluminum	no additional selection required
Brass	no additional selection required
Copper Nickel	70%Cu/30%Ni - 70/30 Copper/Nickel 90%Cu/10%Ni - 90/10 Copper/Nickel
Glass	Pyrex Heavy Silicate Flint Light Borate Crown
Plastic	Nylon Polyethylene Polypropylene PVC (Polyvinyl Chloride), CPVC Acrylic
OTHER	Enter the soundspeed of the pipe material and press [Enter]. If the soundspeed is unknown, refer to the <i>Sound Speeds and Pipe Size Data</i> manual (914-004).

Pipe OD

5. To select the appropriate *Pipe OD Unit* type from the list shown in Table 2-12 below, scroll to the right side of the screen, and use the up and down arrow keys to step through the list. Press [Enter]. Then enter the known pipe outside diameter or circumference on the left side and press [Enter].

Obtain the required information by measuring either the pipe outside diameter (OD) or circumference at the transducer installation site. The data may also be obtained from standard pipe size tables found in *Sound Speeds and Pipe Size Data* (914-004).

Table 2-12: Available Pipe OD Units

English	Metric
inch	mm = millimeters
feet	m = meters
in/PI = pipe circumference in inches	mm/PI = pipe circumference in millimeters
ft/PI = pipe circumference in feet	m/PI = pipe circumference in meters

6. Use the arrow keys to enter the known *Pipe Wall Thickness* (in inches or mm) and press [Enter].

If you are using clamp-on transducers, skip to step 9 on the next page.

Path and Axial Lengths

7. To enter the *Path Length*:
 - a. Use the [▷] arrow key to highlight the path length unit type at the right of the screen. Then use the [△] and [▽] arrow keys to scroll to the desired unit type.
 - b. Use the [◁] arrow key to return to the numeric entry on the left, and enter the path length of the ultrasonic signal. Press [Enter].

Note: *If a spoolpiece was ordered with the meter, the transducer signal path length (P) and the transducer signal axial length (L) are engraved on the flowcell and/or are included in the documentation supplied with the meter. For on-site transducer installations, refer to Appendix C, Measuring P and L Dimensions, for instructions.*

8. In the same manner, enter the appropriate *Axial Length L* unit type and axial length of the ultrasonic signal, and press [Enter]. Skip to step 10 on the next page.

Pipe Lining

9. Scroll to the appropriate choice to indicate whether you have a *Pipe Lining*.
 - a. If you have selected *Yes*, then select the *Lining Material* from the supplied list.
 - If *OTHER* is selected, enter the lining sound speed, and press [Enter].
 - b. Then enter the lining thickness and press [Enter].

Tracking Windows

10. Press the appropriate choice to indicate whether you want *Tracking Windows*. These windows are used to detect the receive signal when you are unsure of the fluid sound speed.

Fluid Type

11. Press the appropriate *Fluid Type*. The selections for fluid type vary depending on whether:
 - the *Energy Option* is ON or OFF; and
 - the *Tracking Window* is enabled or disabled.

Refer to Table 2-13 on the next page if *Energy Option* is OFF, or to Table 2-14 on the next page if *Energy Option* is ON.

Note: *Some of the fluid types may require additional selections, as shown in the following tables.*

Fluid Type (cont.)

Table 2-13: Fluid Types for ENERGY OFF

Tracking Windows =			
NO	Additional Selections	YES	Additional Selections
Water	Normal Water Sea Water Note: If Normal Water is selected, enter the Water Temperature and press [Enter].	Water, 0-100C	No additional selections required.
Oil	Lube Oil Crude Oil	Water, 0-260C	No additional selections required.
Methanol (25 C)	No additional selections required.	Oil, Tracking	No additional selections required.
Ethanol (25C)	No additional selections required.	OTHER	Enter Minimum Soundspeed and press [Enter]. Then enter Maximum Soundspeed and press [Enter].
LN2	No additional selections required.		
Freon	No additional selections required.		
OTHER	Enter the fluid soundspeed and press [Enter].		

Table 2-14: Fluid Types for ENERGY ON

Tracking Windows =			
NO	Additional Selections	YES	Additional Selections
Water	Enter Water Temperature and press [Enter].	Water, 0-260C	No additional selections required.
Water, Glycol Mixture	Enter Fluid Soundspeed and press [Enter]. Then enter Percentage of Water and press [Enter].	Water, Glycol Mixture	Enter Percentage of Water and press [Enter].
OTHER	Enter Fluid Soundspeed and press [Enter].	OTHER	Enter Minimum Soundspeed and press [Enter]. Then enter Maximum Soundspeed and press [Enter].

Reynolds Correction

12. Scroll to the appropriate choice to indicate whether you want *Reynolds Correction*.

- If *Off* is selected, enter the *Calibration Factor* and press [Enter].
- If *Activ* is selected, the program asks for *KV Input Selection*. Scroll to *SIGS (Signals)*, *SOUND (Soundspeed)* or *STATC*.
 - If *SIGS* or *SOUND* is selected, enter the *Calibration Factor* and press [Enter].
 - If *STATC* is selected, enter the *Kinematic Viscosity* and press [Enter]. Then enter the *Calibration Factor* and press [Enter].
- For wetted transducers, the program returns to the Channel PROGRAM menu. You have completed entering PIPE parameters.
- For clamp-on transducers, proceed to step 13 below.

Number of Traverses

13. Scroll to the appropriate *Number of Traverses* (from 1 to 5) and press [Enter].

14. Accept the value for the *Transducer Spacing* by pressing [Enter].

Note: *The XMT868i automatically calculates the transducer spacing. You should not enter a different value unless specifically instructed by the factory.*

PanaView returns to the Channel PROGRAM menu. You have completed entering PIPE parameters.

Note: *The site data programmed in this chapter is automatically stored in the meter's non-volatile RAM (NVR). If the power to the meter is disconnected, the same site data will be applied when the unit is next powered on.*

Procedure Options

Proceed to Chapter 3, *Operation*, for instructions on taking measurements. Or refer to the *Programming Manual* for instructions on programming the Model XMT868i's advanced features.

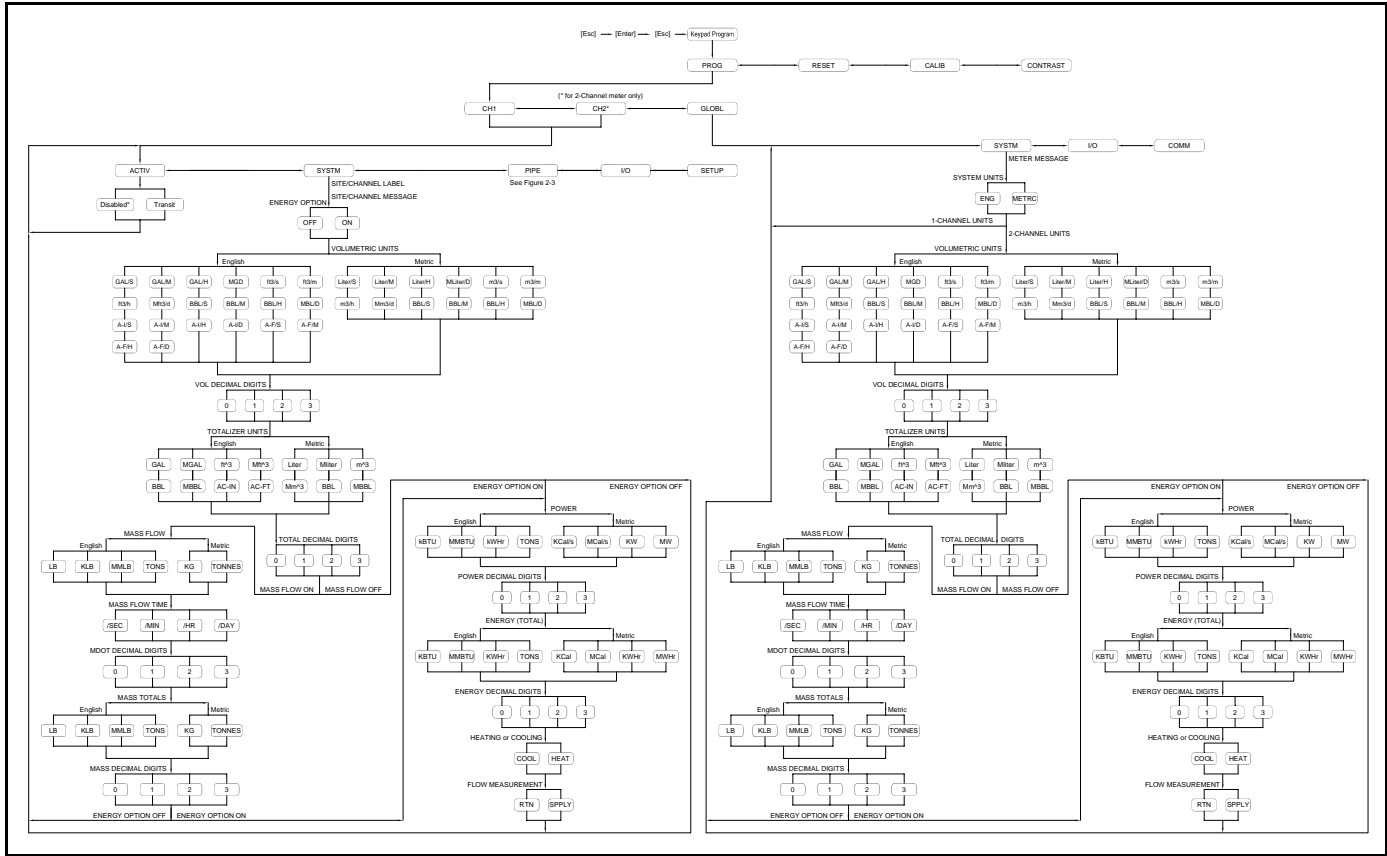

Figure 2-2: Channel-Active, SYSTEM and GLOBL-SYSTEM Menu Map

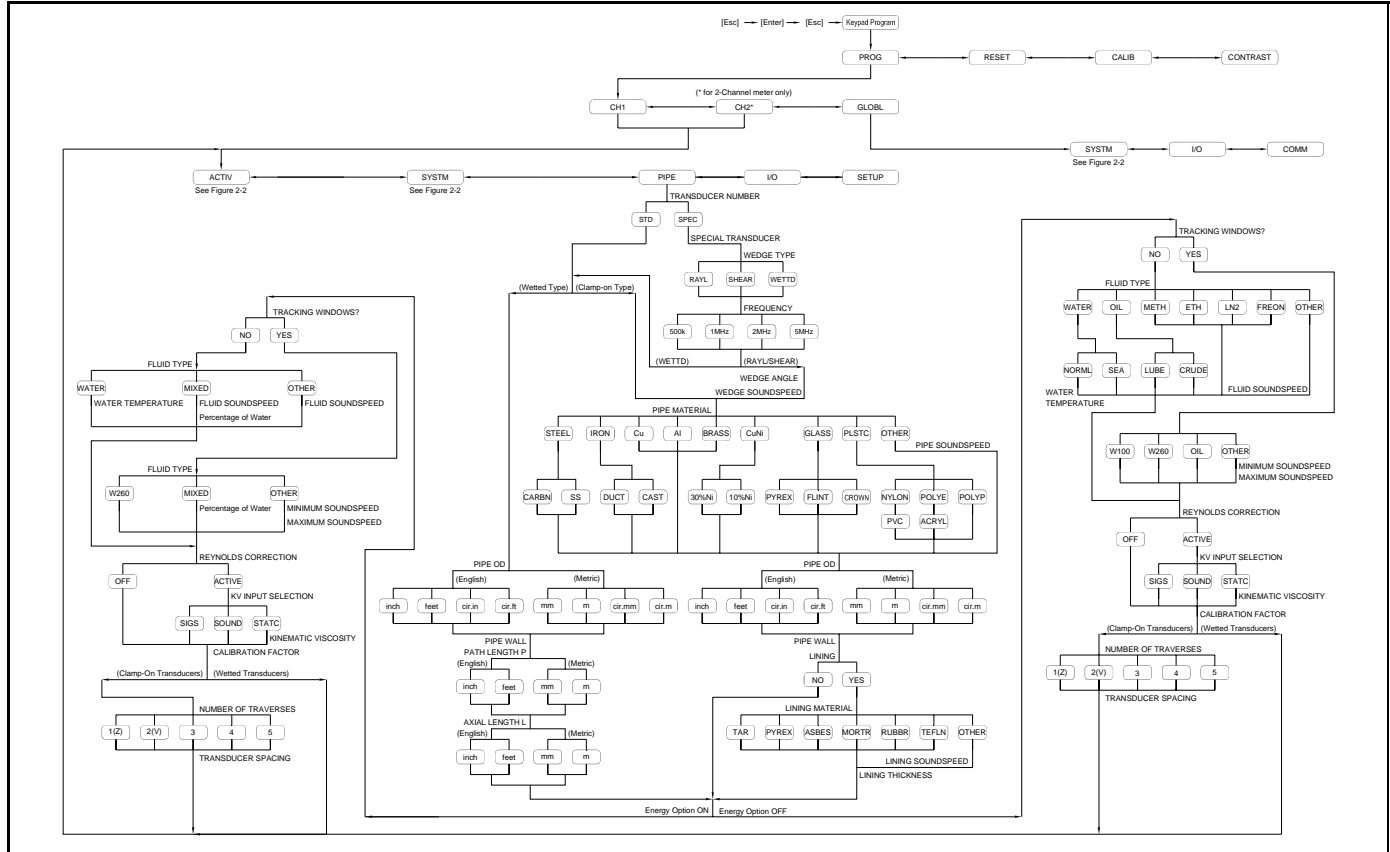

Figure 2-3: Channel-PIPE Menu Map

Chapter 3

Operation

Introduction.....	3-1
Powering Up	3-2
The LCD Display	3-3
The Optional PanaView Display	3-4
Taking Measurements.....	3-5
Procedure Options	3-13

Introduction

See Chapter 1, *Installation*, and Chapter 2, *Initial Setup*, to prepare the Model XMT868i system for operation. When the meter is ready to take measurements, proceed with this chapter. The following specific topics are discussed:

- Powering Up
- Using the Display
- Taking Measurements
- Pausing Measurement

Note: *All inputs and outputs of the Model XMT868i are calibrated at the factory, prior to shipment. If it becomes necessary to recalibrate any of the inputs and/or outputs, see Chapter 1, Calibration, of the Service Manual for instructions.*

!WARNING!

To ensure the safe operation of the Model XMT868i, it must be installed and operated as described in this manual. In addition, be sure to follow all applicable local safety codes and regulations for the installation of electrical equipment.

Powering Up

Because the Model XMT868i does **not** have an ON/OFF switch, it will power up as soon as the connected power source is energized.

Note: *For compliance with the European Union's Low Voltage Directive (73/23/EEC), this unit requires an external power disconnect device such as a switch or circuit breaker. The disconnect device must be marked as such, clearly visible, directly accessible, and located within 1.8 m (6 ft) of the Model XMT868i.*

There are three methods for obtaining readings from the XMT868i:

- Built-in LCD display
- PanaView software on a computer
- Device to read the XMT868i's analog output

At least one of the above display options must be installed in order to obtain flow rate readings from the meter.

Immediately upon power up the software version display appears. Then, the meter performs a series of internal checks, which take about 45 seconds, prior to displaying the flow rate data.

Caution!

The XMT868i conducts the FRAM (non-volatile RAM) test only on the first powering up. If the screen displays the message, "Program Memory Fault Detected," consult the factory immediately. Otherwise, the XMT868i will not repeat the test and may not properly save programmed values.

Note: *If the Model XMT868i fails any of the internal checks (see Chapter 2, Error Codes, in the Service Manual), try disconnecting the power and then repowering the unit. If the meter continues to fail any of the internal checks, contact the factory for assistance.*

After successfully performing the internal checks, the Model XMT868i begins taking measurements and the software version display is replaced by a measurement mode display. Proceed to the appropriate section for instructions on using the LCD display and the PanaView display option.

Note: *As a minimum, the system and pipe parameters (for each installed channel of a 2-channel meter) must be entered before the Model XMT868i can display valid data. Refer to Chapter 2, Initial Setup, for specific instructions.*

The LCD Display

The components of the LCD display are shown in Figure 3-1 below, along with a typical mass flow rate readout.

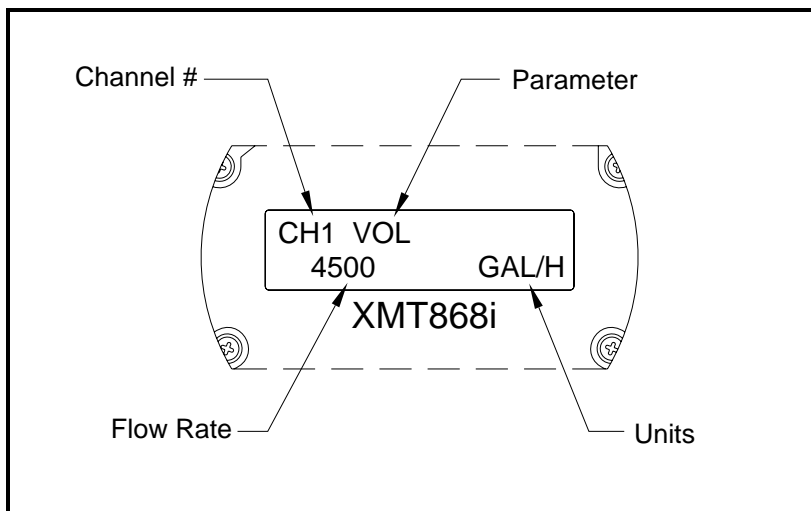

Figure 3-1: A Typical LCD Flow Rate Display

As shown in Figure 3-1 above, the display screen includes the following information:

- Channel Number
- Flow Parameter
- Units of Measure
- Flow Rate Value

The example in Figure 3-1 above uses the default display settings. However, the first three items in the list above may be reprogrammed to display a variety of alternative choices. See the *Programming Manual* for detailed instructions on programming these parameters.

Note: *The LCD backlight flashes to signal errors. If the backlight is off when an error is detected, the display is illuminated briefly; if the backlight is already on, the light is interrupted briefly. Error code messages may appear in the upper right corner of the LCD display. For information about these error codes and how to respond to them, refer to Chapter 2, Error Codes, in the Service Manual.*

Proceed to the *Taking Measurements* section to use the XMT868i.

The Optional PanaView Display

The components of the PanaView text display appear in Figure 3-2 below, along with a typical flow rate readout.

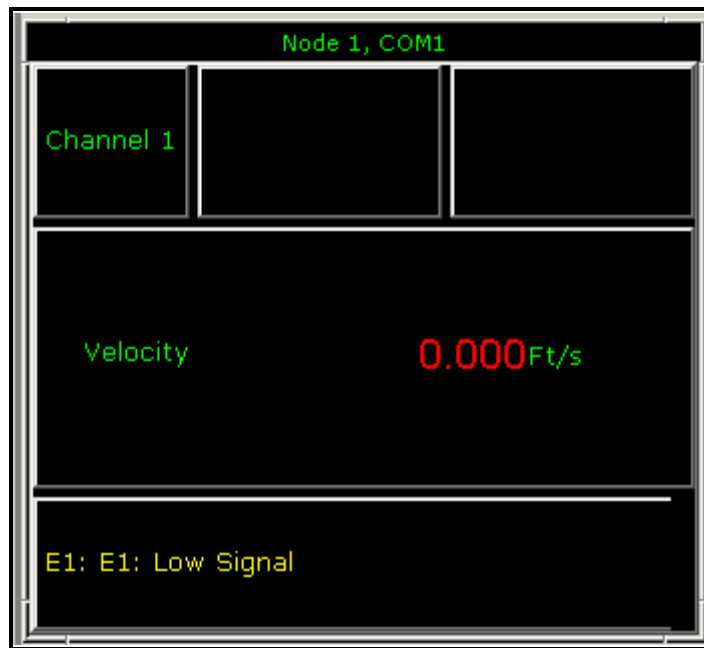

Figure 3-2: A Typical PanaView Text Display Pane

As shown in Figure 3-2 above, the text pane includes the following information:

- Channel Number
- Flow Parameter
- Units of Measure
- Flow Rate Value

The example in Figure 3-2 above is typical, but the first three items in the list above may be reprogrammed to display a variety of alternative choices. See the next section for detailed instructions on programming these parameters.

Note: *Error code messages may appear in the lower left corner of the PanaView text display window. For information about these error codes and how to respond to them, refer to Chapter 2, Error Codes, in the Service Manual.*

Proceed to the *Taking Measurements* section to use the XMT868i.

Taking Measurements

The Model XMT868i is capable of displaying several different variables in a variety of formats. However, this manual will only discuss the basic measurement displays using the LCD display or the PanaView display. Refer to Chapter 2, *Displaying Data*, in the *Programming Manual* for instructions on setting up alternate choices. Also, refer to the *Programming Manual* and/or the *PanaView User's Manual* to use PanaView or the analog outputs to obtain the flow rate data.

Programming the LCD

Note: *When you first initialize the XMT868i, the number of LCD parameters is set to OFF. You must program the LCD to display any measured parameters.*

Through the *Keypad Program*, you can program the LCD display to display up to four variables in sequence. Complete the following steps to program the LCD display:

1. Power up the XMT868i and wait until it has initialized.
2. Press [Escape]. [Enter], [Escape].
3. In the *Keypad Program* window, scroll to PROG and press [Enter].
4. In the PROG menu, scroll to GLOBL and press [Enter].
5. Scroll to I/O and press [Enter].
6. Scroll to LCD and press [Enter].
7. The window now asks for the *# of LCD Parameters*. Scroll to the desired number (from OFF through 1-4 and KEY) and press [Enter].

The OFF setting switches the measurement display off, while the KEY setting enables users to change the measurement display via the arrow keys, without accessing the *Keypad Program*. If you select KEY:

- To view a parameter other than the one currently displayed, press the [◀] and [▶] keys to scroll through the various parameters.
- To view the channel measurements on a two-channel XMT868i, press the [△] or [▽] keys until you have reached the desired channel and measurement.

For a 1-Channel XMT868i, the data for Channel 1 is displayed automatically, and you can skip to step 9. However, for a 2-Channel meter, the channel data to be displayed must be specified at the following prompt.

Programming the LCD
(cont.)

8. Scroll to the desired *Channel option*, as listed in Table 2-1 below.

Table 3-1: Channel Options

Option	Description
CH1	Channel 1
CH2	Channel 2
SUM	CH1+CH2
DIF	CH1-CH2
AVE	(CH1+CH2)/2

9. For each channel, select the desired *Measurement Parameter*, as shown in Table 3-2 below.

Table 3-2: Output Measurement Options

Option Bar Choice	Description
VEL	Flow Velocity
VOLUM	Volumetric Flow
+TOTL	Forward Totalized Volume Flow
-TOTL	Reverse Totalized Volume Flow
TIME	Total Flow Measurement Time
MDOT	Mass Flow
+MASS	Forward Totalized Mass Flow
-MASS	Reverse Totalized Mass Flow
POWER	Energy Flow Power
+ENRG	Forward Energy Flow
-ENRG	Reverse Energy Flow
SS up	Signal strength for the upstream transducer.
SS do	Signal strength for the downstream transducer.
Soundspeed	Measured speed of sound in the fluid.
DAC up	AGC DAC count for upstream gain setting.
DAC do	AGC DAC count for downstream gain setting.
T up	Upstream ultrasonic signal transit time.
Tdown	Downstream ultrasonic signal transit time.
DELTA	Transit time difference between upstream and downstream signals.
REYN#	Current velocity/reynolds number.
K (RE)	K factor, based on the Reynolds number.
PEAK%	Percentage of peak (set to +50 by default).

Table 3-2: Output Measurement Options (cont.)

Option Bar Choice	Description
THETA	Theta 3 is the angle between the ultrasonic beam and the normal to the pipe wall. It is calculated from the measured transit time and the clamp-on parameters (clamp-ons only).
Qup	Displays the signal quality for the upstream transducer.
Qdown	Displays the signal quality for the downstream transducer.
AMPup	Displays the value for the signal amplitude of the upstream transducer.
AMPdn	Displays the value for the signal amplitude of the downstream transducer.
P#up	Displays signal peaks for the upstream transducer.
P#dn	Displays signal peaks for the downstream transducer.
NFup	Displays the normalization factor for the upstream transducer.
NFdn	Displays the normalization factor for the downstream transducer.
Cxdcr	Displays the speed of sound in the transducer (clamp-on only).
TEMPs	Displays the temperature for the supply input (energy measurement).
TEMPr	Displays the temperature for the return input (energy measurement).
Ts-Tr	Difference between supply input and return input measurement (energy measurement).
DENSs	Displays the density for the supply input (energy measurement).
DENSr	Displays the density for the return input (energy measurement).
DELTh	Displays the delta enthalpy which is the difference between the supply and return. Enthalpy is a measure of energy contained in the fluid (energy measurement).

Note: *The measurement units that appear in these prompts are those selected in the GLOBL-SYSTM menu earlier in this section. Also, when differences in one channel's programming invalidate an output previously chosen for the other, the measurement defaults to the nearest selectable item in the parameter list.*

The previous two prompts repeat until all of the specified # of LCD Parameters have been set up. When all of the display parameters have been set up, the meter returns to the Global I/O window. To leave the Keypad Program, press the [Escape] key three times.

After leaving the Keypad Program, the XMT868i will reset itself and will begin to display the parameters specified in this section. If more than one parameter was set up, each of the parameters will be displayed in sequence, with a pause of several seconds between display changes.

Using the LCD Display

To use the programmed LCD display for obtaining flow rate data, simply power on the XMT868i as described earlier in this chapter. Then, read the flow rate directly from the display, as shown in Figure 3-1 on page 3-3.

Note: See Chapter 2, Displaying Data, in the Programming Manual to customize the contents of the LCD display.

PanaView Display

Power up PanaView, establish communications with the XMT868i and enter the required startup parameters, as described in Chapter 2, *Initial Setup*. Then, proceed as follows:

Note: See Chapter 2, *Initial Setup*, in this manual and/or Chapter 1, *Programming Site Data*, in the Programming Manual for complete instructions on entering startup data via PanaView.

1. In PanaView, pull down the *Output* menu, as shown in Figure 3-3 below, and click on the *Text Display* option.

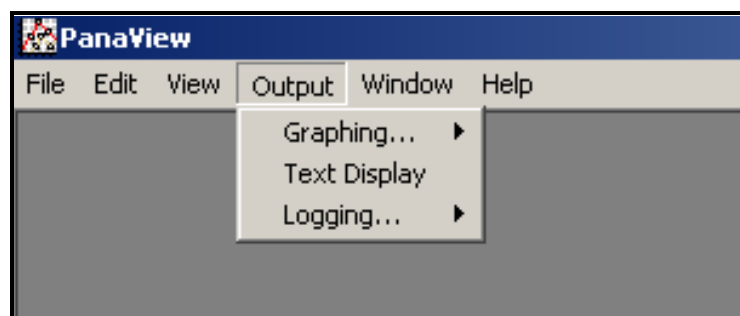

Figure 3-3: The Output Menu

Note: The *Text Display* window that appears after Step 1 is actually stacked on top of any previously opened windows (such as the *Meter Browser* window).

2. Using the *Window* menu, as described on page 5-19 of the *PanaView User's Manual*, arrange the open windows in the desired format. For this discussion, Figure 3-4 below shows the *Text Display* window in its maximized (full-screen) size.

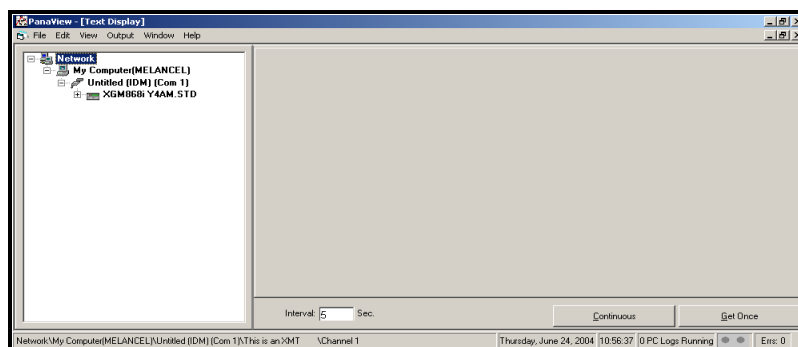

Figure 3-4: The Text Display Window

3. The left pane of the *Text Display* window contains the standard PanaView network tree. Expand the XMT branch, and double-click on the desired channel. (On 2-channel units, you can also display the SUM, DIFF or AVG parameters.)

PanaView Display (cont.)

4. From the expanded tree, double-click on the desired flow parameter to display it in the right pane of the window.
5. Before actual data values can be displayed in the text pane, activate one of the following data collection modes (see Figure 3-4 on the previous page):
 - Click on the [Get Once] option button at the bottom of the right pane in the *Text Display* window. The current value of the selected process parameter, as specified in the PanaView network tree, is displayed in the right pane of the *Text Display* window.

or

- Enter an “*interval*” in the text box at the bottom of the right pane in the *Text Display* window, or check the “*Max. Comm Rate*” box to collect readings as fast as the system allows (1 sec). Then, click on the [Continuous] option button to begin collecting data for display in the right pane of the *Text Display* window.

Note: *Any value entered in the “Interval” text box is overridden if the “Max. Comm Rate” box is checked.*

The right pane now appears similar to Figure 3-2 on page 3-4.

6. If the [Continuous] option was selected in Step 5 above, click on the [Stop] option button, which has replaced the original [Continuous] option button, to terminate data collection.

The *Text Display* window may be left open while other tasks are performed, or it may be closed by clicking on the lower [X] control button at the far right of the menu bar.

IMPORTANT: *If you click on the upper [X] control button at the far right of the PanaView title bar, you will exit PanaView completely.*

Displaying Multiple Process Parameters

The procedure for displaying a single process parameter in a text screen may be repeated to simultaneously display multiple process parameters. To do so, proceed as follows:

1. Display the first process parameter in a text screen, as described in the previous section.
2. Repeat Step 1 for any desired additional process parameters, by double clicking on them in the PanaView network tree. PanaView automatically tiles the multiple text screens in the right pane of the *Text Display* window, as shown in Figure 3-5 below.

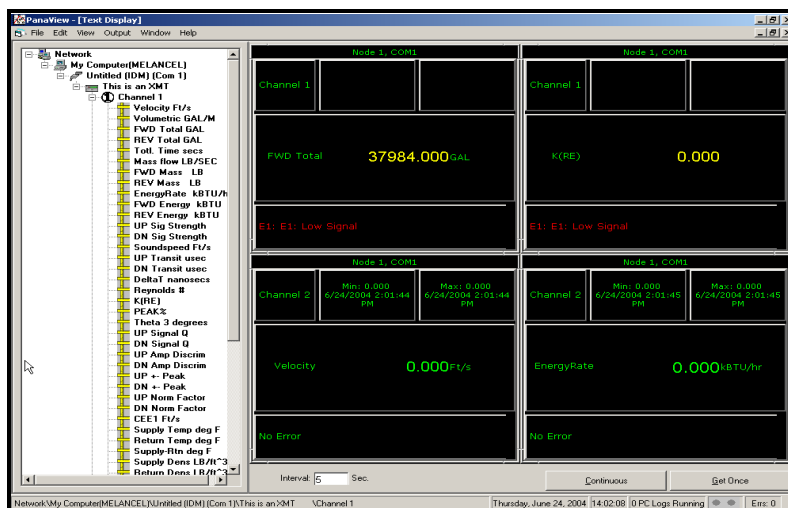

Figure 3-5: Multiple Text Screens in the *Text Display* Window

3. As in any standard Windows application, the multiple text screens may be resized by dragging their borders. Also, the individual panes within a parameter's text screen may be resized by dragging the borders within that text screen.
4. To close an open text screen, right click anywhere within that screen (except in the title bar or the error section) and click on the [Remove] option that pops up in the context menu.

Note: After resizing or removing any of the multiple text screens, the default tiled layout may be restored by opening the *Window* menu (see the PanaView User's Manual) and clicking on the *Tile Output Displays* option.

Displaying Multiple Text Windows

The procedures for displaying one or more process parameters in a single *Text Display* window may be repeated to open multiple *Text Display* windows. To do so, proceed as follows:

1. To open another *Text Display* window and display the desired process parameter(s) in the new window, repeat the steps in *PanaView Display*.
2. Arrange the multiple *Text Display* windows as desired via the *Window* menu (see the *PanaView User's Manual*).

Pausing Measurement

On occasion, it might become necessary for the XMT868i to stop taking measurements. Through *PanaView*, you can direct the XMT868i to pause measurements without cutting off power from the meter.

1. From the meter tree in the *New Meter Browser*, click on the XMT entry.
2. Expand the *Edit Functions* option, and double-click on the *Pause Measurement* entry. A window opens similar to Figure 3-6 below.

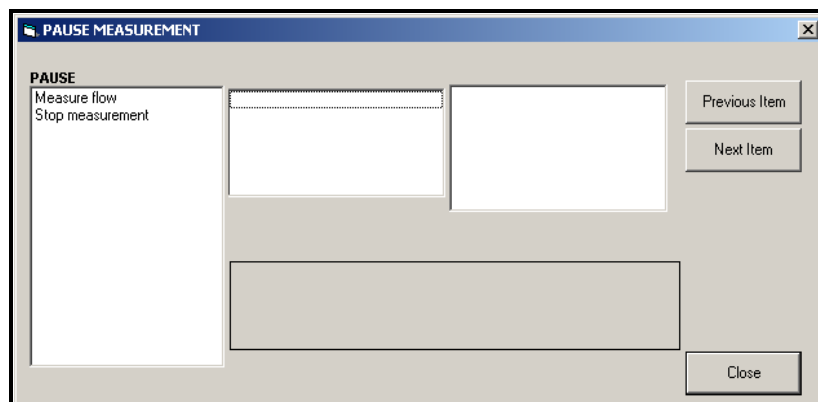

Figure 3-6: The *Pause Measurement* Window

3. To pause current measurements, double-click on the *Stop measurement* option. The window closes, and the XMT868i stops taking measurements.
4. To restart measurement, double-click on the *Pause Measurement* entry, and then on the *Measure flow* option. The XMT868i resumes flow measurement.

Procedure Options

The *Startup Guide* is intended to provide only those instructions necessary to get the XMT868i installed and operating. By following the instructions in this chapter, the Model XMT868i can be set up to display the desired channel option and the desired measurement parameter, using either the LCD display or PanaView.

To utilize the more advanced capabilities of the Model XMT868i, refer to the *Programming Manual* and/or the *Service Manual* for the instrument. Also, refer to the *PanaView User's Manual* for instructions on using the PanaView software with the XMT868i.

Chapter 4

Specifications

- General..... 4-1
- Electrical..... 4-2
- Transducer..... 4-4
- Pipe Size and Materials..... 4-6
- Flowcell..... 4-7

General	The general specifications for the Model XMT868i flow transmitter are divided into the following categories:
Hardware Configuration	<p>Channel Options: <i>Standard:</i> 1 Channel. <i>Optional:</i> 2 Channel (2 pipes or 2 paths per pipe).</p> <p>Mode Options: Transit-Time.</p> <p>Package Options: <i>Standard:</i> Epoxy-coated aluminum Type 7/4X, IP66 Explosion proof Class I, Div. 1, Groups B, C & D. Class II, Groups E, F & G; Class III Flameproof Ex II 2 GD EEx d IIC T5/T6 <i>Optional:</i> Stainless steel Type 7/4X. Explosion proof Class I, Div. 1, Groups B, C & D. Class II, Groups E, F & G; Class III Flameproof Ex II 2 GD EEx d IIC T5/T6</p> <p>Dimensions: <i>Standard housing:</i> 10 lb (4.5 kg); 8.2 x 6.6 in. (208 x 168 mm). <i>Optional housing:</i> 30 lb (13.6 kg); 8.2 x 6.6 in. (208 x 168 mm).</p>
Environmental	<p>Operating Temperature: -40° to 140°F (-40° to 60°C).</p> <p>Storage Temperature: -67° to 167°F (-55° to 75°C).</p>
Flow Accuracy (Velocity)	<p>Accuracy specifications assume a fully developed flow profile and a straight run of 10 pipe diameters upstream and 5 pipe diameters downstream.</p> <p>±0.5% of reading (achievable with process calibration)</p> <p>Typical Clamp-On Flow Accuracy (Velocity) Pipe Diameter (ID) > 6 in. (150 mm): ±1% to 2% of reading Pipe Diameter (ID) ≤ 6 in. (150 mm): ±2 to 5% of reading</p> <p>Typical Wetted Flow Accuracy (Velocity): ±1% of reading</p> <p>Note: Accuracy depends on pipe size, installation and whether measurement is one-path or two-path.</p>

Range	<p>Transit-Time Mode: -40 to 40 ft/s (-12.2 to 12.2 m/s).</p>
Rangeability (Overall)	400:1.
Repeatability	±0.1% to 0.3 of reading
Energy Accuracy (% of Reading):	<p>The accuracy of the energy measurement is a combination of the accuracy of the flow and temperature measurements.</p> <p>Transit-Time Mode: Accuracy of 1% is typical for calibrated systems.</p> <p>Note: <i>Above specifications require a straight run of 10 pipe diameters upstream and 5 pipe diameters downstream.</i></p>
Fluid Types	<p>Transit-Time Mode: Acoustically-conductive fluids. This includes most clean liquids and many with entrained solids or gas bubbles (the maximum void fraction depends on the transducer, interrogation carrier frequency, path length and pipe configuration). Consult the factory for additional information.</p>
Electrical	The electrical specifications for the Model XMT868i flow transmitter are divided into the following categories:
Power Supply	<p>Options: <i>Standard:</i> 95 to 240 VAC, 50/60 Hz, ± 10%. <i>Optional:</i> 12 to 28 VDC, ± 5%.</p> <p>Power Consumption: 20 W maximum.</p>
Operating Modes	<p>Flow Measurement: <i>Standard:</i> Correlation Transit-Time™ Mode with clamp-on or wetted transducers.</p> <p>Energy Measurement (optional): To calculate energy flow rate, use Analog Input Board for transmitters. Use RTD Input Board for direct RTDs.</p>
European Compliance	This unit complies with EMC Directive 89/336/EEC and 73/23/EEC Low Voltage Directive (Installation Category II, Pollution Degree 2), and transducers comply with PED 97/23/EC for DN<25.

Input/Output

Digital Display:

2-line x 16-character LCD display, LED backlight, configurable to display up to 4 measurement parameters in sequence, or to scroll through measurement parameters

Digital Communications:

Standard: RS232 serial port for PC, terminal or printer.

Optional: RS485 serial port for multi-user network.

RS485 MODBUS communication

MODBUS/TCP

OPC Server

Ethernet

Foundation Fieldbus

Analog Outputs (built-in):

Standard: Two isolated 0/4–20 mA, 600 Ω max. load.

Option Cards:

Optional Inputs/Outputs of the following types may be added:

1. *Analog Inputs:* two isolated 0/4-20 mA inputs, 24-V loop power.
2. *RTD Inputs:* two isolated 3-wire RTD inputs; Span -148° to 662°F (-100° to 350°C), 100 Ω Pt., Alpha 385.
3. *Analog Outputs:* two isolated 0/4–20 mA analog outputs, 1000 Ω maximum load.
4. *Data Logging:* 128 kB or 2 MB memory.
5. *Totalizer or Frequency Outputs:* two or four optically isolated pulse or frequency outputs, 100 VDC/3 A/1 W/10 KHz max.

Totalizer Mode: one pulse per defined unit of parameter (e.g., 1 pulse/gal).

Frequency Mode: pulse frequency proportional to magnitude of parameter (e.g., 10 Hz = 1 gal/min).

6. *Alarm Relays:* two or four Form-C relays

General Purpose: 120 VAC, 28 VDC max., 5 A max.,
DC: 30 W max., AC: 60 VA max.

Note: *The above optional inputs/outputs are available only in specific combinations. Consult GE Sensing or see Table B-1 on page B-1 for details.*

Additional Options

PC-Interface Software:

PanaView™ software option links the XMT868i to a PC. Software package includes CD and manual.

Transducer

Wetted Transducers

Material:

Standard: 316 Stainless Steel.

Optional (for isolating PanAdapta Plugs[®]): Hastelloy, Monel, Titanium, Duplex, CPVC, PVDF and others.

Process Connection:

Standard: 1-in. NPTM, 3/8-in. NPTM.

Optional: RF flange, socket weld, fuse bond and others.

Maximum Pressure:

Standard: 0 to 3,000 psig (0.1013 to 20 MPa).

Optional: Higher pressures on request.

Temperature Range:

Standard: -40° to 212°F (-40° to 100°C).

Optional (overall range): -310° to 932°F (-190 to 500°C).

Mounting:

Spoolpiece, hot tap, or cold tap.

Area Classifications:

Standard: General-purpose

Optional:

Explosion proof: Class I, Div. 1, Groups B, C & D; Class II, Groups E, F and G; Class III

Flameproof: Ex II 2 G EEx d IIC T6

Weatherproof: Type 4/IP65.

Submersible.

Note: *Wetted transducers for special applications and flowcells are also available. Consult the factory for details.*

Clamp-On Transducers

Temperature Range:

Standard: -40° to 300°F (-40° to 150°C).

Optional (overall range): -310° to 572°F (-190° to 300°C).

Mounting:

SS chain or strap, welded or magnetic clamping fixtures.

Area Classifications:

Standard: General-purpose

Optional:

Explosion proof: Class I, Div. 1, Groups B, C & D; Class II, Groups E, F and G; Class III

Flameproof: Ex II 2 G EEx md IIC T6-T3.

Weatherproof: Type 4/IP65.

Submersible.

Note: *Clamp-on transducers for special applications and flowcells are also available. Consult the factory for details.*

Transducer Cables

Length:

Standard: Pair of coaxial cables, type RG62 aU, length to 3 ft (1 m).

Optional: Lengths up to 1000 ft (330 m) maximum.

Temperature Transducers
(optional)**Type:**

Loop-powered 3-wire platinum RTDs; clamp-on and wetted (thermowell) types are available.

Range:

-4° to 500°F (-20° to 260°C), not all extremes of parameters can be achieved simultaneously.

Accuracy:

0.27°F (0.15°C), wetted RTDs, matched pairs.

Pipe Size and Materials

Wetted Transducers

Materials:

All metals and most plastics. (Consult the factory for concrete, glass and cement.)

Pipe Sizes:

Transit-Time Mode: Inside diameter 1 to 200 in.

Clamp-on Transducers

Materials:

All metals and most plastics. (Consult the factory for concrete, composite materials and highly corroded or lined pipes.)

Pipe Sizes:

Transit-Time Mode:

Outside Diameter: 0.5 to 300 in. (12.7 mm to 7.6 m) and larger.

Pipe Wall Thickness:

Up to 3 in. (76.2 mm).

Flowcell

Tilted Diameter

Pipe Sizes:

Standard: 2 to 200 in. (50 to 5,000 mm).

Optional: >200 in.

Material:

Standard: Stainless steel; carbon steel; plastics; fiberglass.

Optional: Other metals; plastics; etc.

Process Connection:

Standard: Straight (welding); 150-lb flange; 300-lb flange.

Optional: MJ; Victaulic; RTJ flanged; cold tap.

Wetted Transducer Connection:

1" NPTM for 6 in. or greater pipe sizes; 3/8" NPTM for 2 to 5 in. sizes.

Interrogation:

Standard: Conventional 45° tilted-diameter; one or more traversals.

Optional: Mid-radius chord; multi-chords including multiple paths.

Appendix A

CE Mark Compliance

Introduction.....A-1

Wiring.....A-1

Introduction

For CE Mark compliance, the Model XMT868i flow transmitter must be wired in accordance with the instructions in this appendix.

IMPORTANT: *CE Mark compliance is required only for units intended for use in EEC countries.*

Wiring

The Model XMT868i must be wired with the recommended cable, and all connections must be properly shielded and grounded. Refer to Table A-1 below for the specific requirements.

Table A-1: Wiring Requirements

Connection	Cable Type	Ground Termination
Transducer	Armored RG62 a/U	Grounded using a cable gland.
Input/ Output	Armored 22 AWG shielded (e.g. Baystate #78-1197) with armored material added to outside of jacket	Grounded using a cable gland.
Power	Armored 14 AWG 3 conductor	Grounded using a cable gland.

Note: *If the Model XMT868i is wired as described in this appendix, the unit will comply with the EMC Directive 89/336/EEC.*

Appendix B

Data Records

- Available Option Cards B-1
- Option Cards Installed B-2
- Site Data..... B-3

Available Option Cards

The XMT868i can accommodate one option card in Slot 1 and one in Slot 2. The available configurations are listed in Table B-1 below.

Table B-1: Option Card Configurations

Card #713-	Slot #	Configuration
1215-02	1	FF - 4 Frequency Outputs
1215-03		TT - 4 Totalizer Outputs
1215-04		FT - 2 Frequency Outputs/2 Totalizer Outputs
1215-05		FO - 2 Frequency Outputs
1215-06		TO - 2 Totalizer Outputs
1215-07		AA - 4 Standard Alarms
1215-09		FA - 2 Frequency Outputs/2 Standard Alarms
1215-11		TA - 2 Totalizer Outputs/2 Standard Alarms
1223-02/1473-02		OI - 2 Current Inputs
1223-03/1473-03		OR - 2 RTD Inputs
1223-04/1473-04		TI - 2 Current Inputs/2 Totalizer Inputs
1223-05/1473-05		TR - 2 RTD Inputs/2 Totalizer Inputs
1223-06/1473-06		FI - 2 Current Inputs/2 Frequency Inputs
1223-07/1473-07		FR - 2 RTD Inputs/2 Frequency Inputs
1223-08/1473-08		AI - 2 Current Inputs/2 Standard Alarms
1223-10/1473-10		AR - 2 RTD Inputs/2 Standard Alarms
1225-13		CO - 2 Current Outputs
1225-14		CF - 2 Current Outputs/2 Frequency Outputs
1225-15		CT - 2 Current Outputs/2 Totalizer Outputs
1225-16		CA - 2 Current Outputs/2 Standard Alarms
1430-03	RR - 4 RTD Inputs	
1430-04	IR - 2 RTD Inputs/2 Current Inputs	
1146-02/1332-02	2	128 KB Memory
1146-03/1332-03		2 MB Memory
1345-04		Modbus Communications Protocol
1477-03	2	MODBUS/TCP/IP
1477-01	2	Ethernet
1475-01	2	Foundation Fieldbus

Option Cards Installed

Whenever an option card is installed or changed in the XMT868i flow transmitter, record the type of card and any additional setup information in the appropriate row of Table B-2 below.

Table B-2: Option Cards Installed

Slot #	Type of Option Card	Additional Setup Information
0	Analog Outputs (A, B)	
1		
2		

Site Data

After the Model XMT868i flow transmitter has been installed, specific site data must be entered via the *Keypad Program*, prior to operation. Record that information in Table B-3 below.

Table B-3: Site Data

General Information					
Model #			Serial #		
Software Vers.			Setup Date		
GLOBL-SYSTEM					
Meter Message			Vol. Dec. Digits		
System Units	English	Metric	Totalizer Units		
Vol. Units			Tot. Dec. Dig.		
GLOBL-I/O-ERROR					
Error Handling			2-Path Error	No	Yes
GLOBL-COMM					
Meter Address			MOD. Parity		
Baud Rate			MOD. Stop Bits		
MOD. Baud Rate			MOD. Address		
CHANNEL X-ACTIV					
Channel 1			Channel 2 (if applicable)		
Channel Status	Off ¹	Trans	Channel Status	Off ¹	Trans
CHANNEL X-SYSTM					
Channel 1			Channel 2 (if applicable)		
Channel Label			Channel Label		
Chan. Message ²			Chan. Message ²		
Energy Option	On	Off	Energy Option	On	Off
Vol. Units			Vol. Units		
Vol. Dec. Digits			Vol. Dec. Digits		
Totalizer Units			Totalizer Units		
Tot. Dec. Dig.			Tot. Dec. Dig.		
Mass Flow			Mass Flow		
Mass Flow Time			Mass Flow Time		
MDOT Dec. Dig.			MDOT Dec. Dig.		
Mass Totals			Mass Totals		
Mass Dec. Digits			Mass Dec. Digits		
Power			Power		
Power Dec. Dig.			Power Dec. Dig.		
Energy (Total)			Energy (Total)		
Energy Dec. Dig.			Energy Dec. Dig.		
Heat. or Cool.			Heat. or Cool.		
Flow Meas.			Flow Meas.		
¹ not available for 1-Channel meter, ² "Site Message" for 1-Channel meter					

Table B-3: Site Data (cont.)

CHANNELx-I/O									
Zero Cutoff				Temp. Input	Fixed ()	Live			
Pipe/Transducer Parameters - PIPE									
Channel 1					Channel 2 (if applicable)				
Trans. Type	STD		SPEC		Trans. Type	STD		SPEC	
Transducer #					Transducer #				
Special Transducers					Special Transducers				
Wedge Type	Rayl	Shear	Wettd		Wedge Type	Rayl	Shear	Wettd	
Frequency Hz					Frequency Hz				
Trans. Tw					Trans. Tw				
Wedge Angle					Wedge Angle				
Wedge Sndspd					Wedge Sndspd				
Pipe Material					Pipe Material				
All Clamp-On and Wetted Transducers					All Clamp-On and Wetted Transducers				
Pipe O.D.					Pipe O.D.				
Pipe Wall					Pipe Wall				
Path Length (P)					Path Length (P)				
Axial Length (L)					Axial Length (L)				
Lining	Yes	No			Lining	Yes	No		
Lining Material					Lining Material				
Lining Sndspd					Lining Sndspd				
Lining Thickness					Lining Thickness				
Track. Window.	Yes	No			Track. Window.	Yes	No		
Fluid Type					Fluid Type				
Other/Sndspd					Other/Sndspd				
% of Water					% of Water				
Reynolds Corr.	Off	Active			Reynolds Corr.	Off	Active		
KV Input Sel.	Table	Static			KV Input Sel.	Table	Static		
Kin. Visc.					Kin. Visc.				
Cal. Factor					Cal. Factor				
# of Traverses					# of Traverses				
Trans. Spacing					Trans. Spacing				
Response Time					Response Time				
CHANNELx-SETUP-ADVANCED FEATURES-MASS FLOW									
Mass Flow	No	Yes			Mass Flow	No	Yes		
Static Density					Static Density				
CHANNELx-SETUP-ADVANCED FEATURES-CODE LENGTH									
Code Length	Auto	Short	Long		Code Length	Auto	Short	Long	

Table B-3: Site Data (cont.)

CHx-SETUP-ADVANCED FEATURES-KV/SS					
KV/SS (or C3) Pairs			KV/SS (or C3) Pairs		
#	Sig. Stren./ Soundspeed	Kin. Visc.	#	Sig. Stren./ Soundspeed	Kin. Visc.
1			1		
2			2		
3			3		
4			4		
5			5		
6			6		
7			7		
8			8		
9			9		
10			10		
11			11		
12			12		
13			13		
14			14		
15			15		
16			16		
17			17		
18			18		
19			19		
20			20		
CHx-SETUP-ADVANCED FEATURES-MULTIK					
Custom Type	CstV	CstR	CustomType	CstV	CstR
K-Factor Table			K-Factor Table		
K-Factor #	Vel./Reyn.	K Factor	K-Factor #	Vel./Reyn.	K Factor
1			1		
2			2		
3			3		
4			4		
5			5		
6			6		
7			7		
8			8		
9			9		
10			10		
11			11		
12			12		
13			13		

Table B-3: Site Data (cont.)

CHx-SETUP-ADVANCED FEATURES-MULTIK (cont.)						
K-Factor #	Vel./Reyn.	K Factor		K-Factor #	Vel./Reyn.	K Factor
14				14		
15				15		
16				16		
17				17		
18				18		
19				19		
20				20		

Appendix C

Measuring P and L Dimensions

Measuring P and LC-1

Measuring P and L

If you are using wetted transducers, the XMT868i requires you to enter the path length (P) and the axial dimension (L). P is the transducer face-to-face distance, and L is the axial projection of P in the flow stream.

To determine L, physically measure the distance between the center of the transducer ports at the inside wall as shown in Figure 2-1 below, if possible. If not, consult the factory.

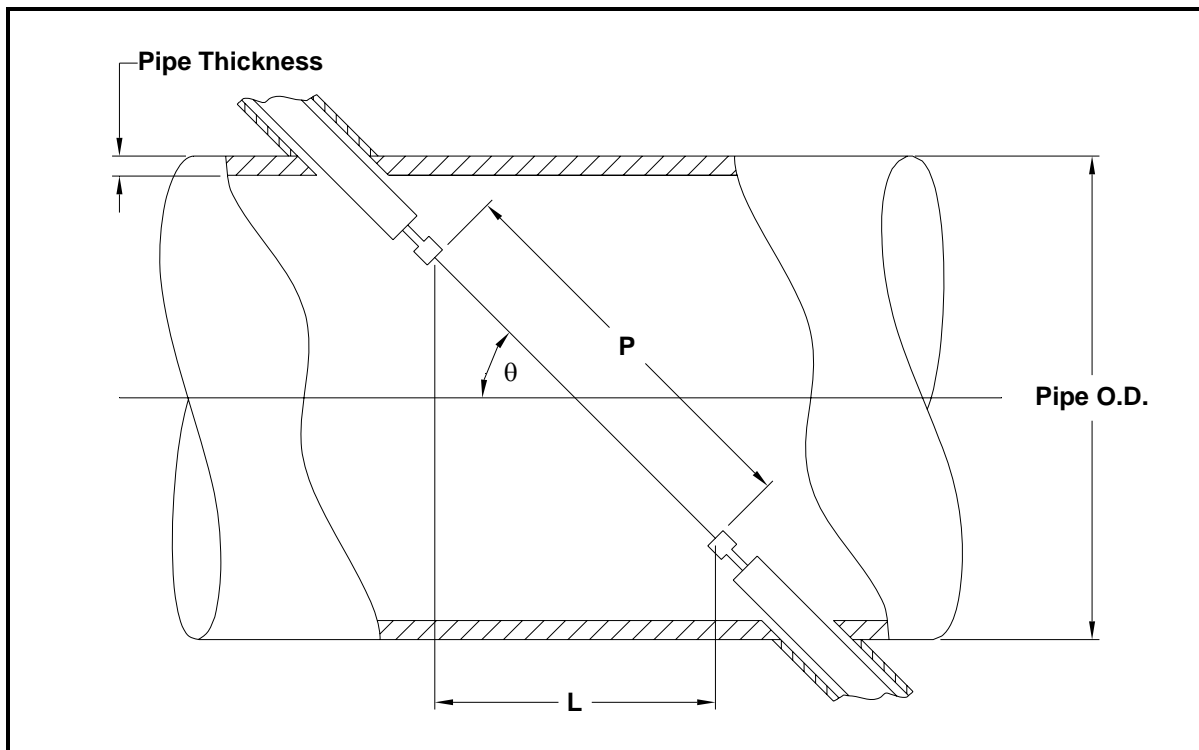

Figure 2-1: 180° Transducer Installations - Top View

To determine P, you need the following:

- the pipe inside diameter (ID)
- the wall thickness (WT)
- the installed pipe coupling length (CL)
- the transducers face depth (FD)
- the mounting angle (MA)

Measuring P and L (cont.) Use Figure C-2 below to properly measure the coupling length. Typically, the transducer face is positioned just outside the inside diameter (ID) of the pipe, or slightly retracted inside the coupling.

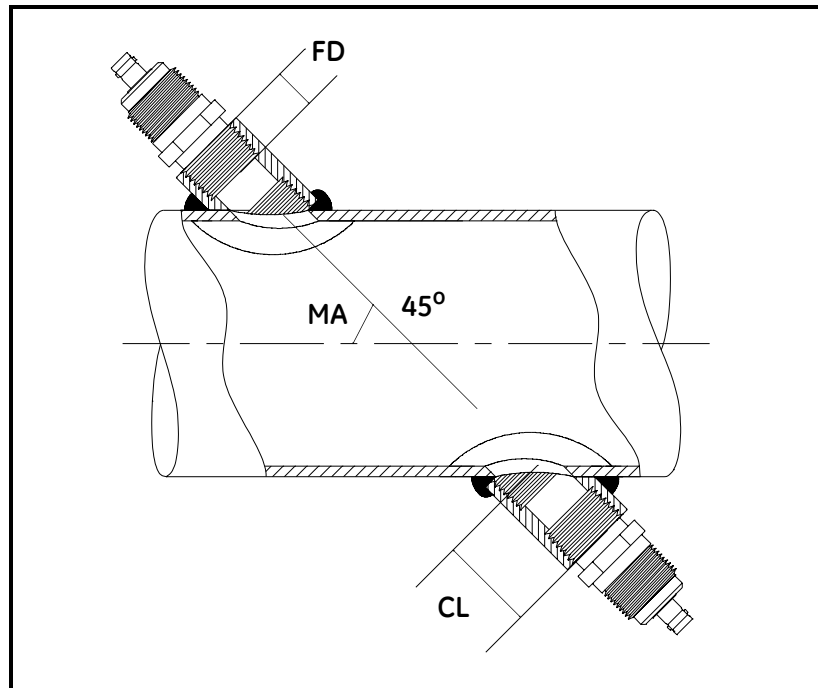

Figure C-2: Determining the Pipe Coupling Length

Use the following formula to determine P dimension:

$$[ID + 2(WT)]/(\cos MA) + 2(CL) - FD = P \text{ Dimension.}$$

For example, given the following:

- inside diameter (ID) = 48"
- wall thickness (WT) = 3/8"
- installed coupling length (CL) = 2.0"
- a transducer face depth (FD) = 1.75"
- mounting angle (MA) - 45°

The P dimension would be

$$[48 + 2(3/8)]/(0.7071) + 2(2.0 - 1.75) = 69.4"$$

Index

- A**
- ACTIV Submenu 2-9
- Alarms Option Card
- Connecting 1-13
 - Fail-Safe Operation 1-14
- Analog Inputs Option Card
- Connecting 1-15
 - Pin Assignments 1-15
 - Rating 1-15
- Analog Outputs
- Units Options 3-6
- Analog Outputs (Slot 0)
- Connecting 1-10
- Analog Outputs Option Card
- Connecting 1-17, 1-20
- Arrow Keys 2-2
- Axial Length 2-16
- C**
- Cable
- Serial Port 1-11
 - Transducers 1-3
- CE Mark Compliance A-1
- Channel Label 2-10
- Channel Menu 2-9
- Channel Message 2-10
- Channel-SYSTEM Submenu 2-10
- CHx Menu 2-9
- Connecting
- See Part Name
- Connectors, Electrical 1-6
- D**
- Display
- Data 3-2
 - Measurement Mode 3-2
- Down Arrow Key 2-2
- E**
- Electrical Connectors 1-6
- Electronics Console
- Description 1-2
 - Mounting 1-5
- Energy Option, Enabling 2-10
- Energy Option, Programming 2-8, 2-13
- Enter Key 2-2
- Escape Key 2-2
- Ethernet, Wiring the 1-19
- F**
- Flowcell
- Installing 1-4
- Fluid Type 2-17
- Fluid Type, Selecting 2-17
- Foundation Fieldbus
- Terminal Block Connectors 1-25
- Frequency
- for Special Transducers 2-14
- Fuse Ratings 4-2
- G**
- Global
- Menu 2-4
 - Submenus 2-4
- Global Menu
- I/O Submenu
 - LCD Option 3-5
- GLOBL Menu 2-4
- GLOBL-SYSTEM Submenu 2-4
- I**
- I/O (Global) Submenu
- LCD Option 3-5
- Infrared Keypad, Using 2-2
- Initial Setup
- Data Table B-3
 - Minimum Required 2-1
- Input Voltage 1-7
- Internal Tests 3-2

Index (cont.)

- | S | U |
|---|---|
| Serial Port | Unpacking 1-2 |
| Cable 1-11 | Up Arrow Key 2-2 |
| Connecting 1-11, 1-12 | User Program |
| Pin Assignments 1-11, 1-12 | Global Menu |
| Slot 0 | LCD Option 3-5 |
| Output Measurement Options 3-6 | |
| See Analog Outputs (Slot 0) | |
| Special Transducers, Programming 2-14 | |
| Specifications | |
| Electrical 4-2 | |
| General 4-1 | |
| Transducer 4-4, 4-5 | |
| System (Channel) Submenu 2-10 | |
| System (Global) Submenu 2-4 | |
| System Data | |
| Entering in GLOBL Menu 2-4 | |
| System Units | |
| in GLOBL-SYSTM Submenu 2-4 | |
| | |
| T | V |
| Temperature Transmitter | Voltage, Input 1-7 |
| Installing 1-4 | Volumetric Units |
| Terminal Block | in Channel Menu 2-10 |
| Analog Outputs - I/O 1-10 | in GLOBL Menu 2-5 |
| Power - TB1 1-7 | |
| Serial Port - RS232 1-11 | |
| Serial Port - RS485 1-12 | |
| Time Delay 2-14 | |
| Totalizer Units | |
| in Channel Menu 2-11 | |
| in GLOBL Menu 2-6 | |
| Totalizer/Frequency Option Card | |
| Connecting 1-16 | |
| Tracking Windows 2-17 | |
| Transducer Number 2-14 | |
| Transducer Parameters, Programming 2-14 | |
| Transducers | |
| Axial Dimension C-1 | |
| Cables 1-3 | |
| Installation Angle C-1 | |
| Location 1-3 | |
| Path Length C-1 | |
| Transmitter | |
| LCD, Setting Up 3-5 | |
| | |
| | W |
| | Wedge Angle 2-15 |
| | Wedge Soundspeed 2-15 |
| | Wedge Temperature 2-15 |
| | Wedge Type 2-14 |
| | Windows |
| | Resizing 3-11 |
| | Tiling 3-11 |
| | Wiring |
| | CE Mark Compliance A-1 |
| | Option Card See Card Name |
| | Terminal Block See Block Name |

We,

**Panametrics Limited
Shannon Industrial Estate
Shannon, County Clare
Ireland**

declare under our sole responsibility that the

**DigitalFlow™ XGM868i Ultrasonic Gas Flow Transmitter
DigitalFlow™ XGS868i Ultrasonic Steam Flow Transmitter
DigitalFlow™ XMT868i Ultrasonic Liquid Flow Transmitter**

to which this declaration relates, are in conformity with the following standards:

- EN 50014:1997+A1+A2:1999
EN 50018:2000
EN50281-1-1:1998
as specified in: ISSeP02ATEX008; II 2 GD EEx d IIC T5
ISSeP, B7340 Colfontaine, Belgium
- EN 61326:1998, Class A, Annex A, Continuous Unmonitored Operation
- EN61010-1:1993+A2:1995, Overvoltage Category II, Pollution Degree 2
- EN 60529:1991+A1:2000
IP66

following the provisions of the 89/336/EEC EMC Directive, the 94/9/EC ATEX Directive and the 73/23/EEC Low Voltage Directive.

The units listed above and any transducers supplied with them (spoolpieces are addressed under a separate declaration of conformity) do not bear CE marking for the Pressure Equipment Directive, as they are supplied in accordance with Article 3, Section 3 (sound engineering practices and codes of good workmanship) of the Pressure Equipment Directive 97/23/EC for DN<25.

Shannon - December 7, 2004

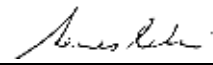

Mr. James Gibson
GENERAL MANAGER



CERT-DOC-H4



August 2004

Nous,

Panametrics Limited
Shannon Industrial Estate
Shannon, County Clare
Ireland

déclarons sous notre propre responsabilité que les

DigitalFlow™ XGM868i Ultrasonic Gas Flow Transmitter
DigitalFlow™ XGS868i Ultrasonic Steam Flow Transmitter
DigitalFlow™ XMT868i Ultrasonic Liquid Flow Transmitter

relatif à cette déclaration, sont en conformité avec les documents suivants:

- EN 50014:1997+A1+A2:1999
EN 50018:2000
EN50281-1-1:1998
as specified in: ISSeP02ATEX008; II 2 GD EEx d IIC T5
ISSeP, B7340 Colfontaine, Belgium
- EN 61326:1998, Class A, Annex A, Continuous Unmonitored Operation
- EN61010-1:1993+A2:1995, Overvoltage Category II, Pollution Degree 2
- EN 60529:1991+A1:2000
IP66

suivant les règles de la Directive de Compatibilité Electromagnétique 89/336/EEC, d'ATEX 94/9/EC et de la Directive Basse Tension 73/23/EEC.

Les matériels listés ci-dessus ainsi que les transducteurs pouvant être livrés avec (les manchettes faisant l'objet d'une déclaration de conformité séparée) ne portent pas le marquage CE de la directive des équipements sous pression, car ils sont fournis en accord avec la directive 97/23/EC des équipements sous pression pour les DN<25, Article 3, section 3 qui concerne les pratiques et les codes de bonne fabrication pour l'ingénierie du son.

Shannon - December 7, 2004

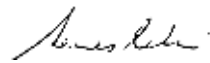

Mr. James Gibson
DIRECTEUR GÉNÉRAL



CERT-DOC-H4



August 2004

Wir,

**Panametrics Limited
Shannon Industrial Estate
Shannon, County Clare
Ireland**

erklären, in alleiniger Verantwortung, daß die Produkte

**DigitalFlow™ XGM868i Ultrasonic Gas Flow Transmitter
DigitalFlow™ XGS868i Ultrasonic Steam Flow Transmitter
DigitalFlow™ XMT868i Ultrasonic Liquid Flow Transmitter**

folgende Normen erfüllen:

- EN 50014:1997+A1+A2:1999
EN 50018:2000
EN50281-1-1:1998
as specified in: ISSeP02ATEX008; II 2 GD EEx d IIC T5
ISSeP, B7340 Colfontaine, Belgium
- EN 61326:1998, Class A, Annex A, Continuous Unmonitored Operation
- EN61010-1:1993+A2:1995, Overvoltage Category II, Pollution Degree 2
- EN 60529:1991+A1:2000
IP66

gemäß den Europäischen Richtlinien, Niederspannungsrichtlinie Nr.: 73/23/EG und EMV-Richtlinie Nr.: 89/336/EG und ATEX Richtlinie Nr. 94/9/EG.

Die oben aufgeführten Geräte und zugehörige, mitgelieferte Schallwandler (Messrohre werden in einer separaten Konformitätserklärung behandelt) tragen keine CE-Kennzeichnung gemäß der Druckgeräte-Richtlinie, da sie in Übereinstimmung mit Artikel 3, Absatz 3 (gute Ingenieurpraxis) der Druckgeräte-Richtlinie 97/23/EG für DN<25 geliefert werden.

Shannon - December 7, 2004

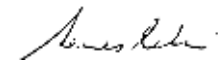

Mr. James Gibson
GENERALDIREKTOR



CERT-DOC-H4



August 2004

We,

GE Sensing, Inc.
1100 Technology Park Drive
Billerica, MA 01821-4111
U.S.A.

as the manufacturer, declare under our sole responsibility that the product

XMT868 Liquid Ultrasonic Flow Transmitter

to which this document relates, in accordance with the provisions of ATEX Directive 94/9/EC Annex II, meets the following specifications:



Furthermore, the following additional requirements and specifications apply to the product:

- Having been designed in accordance with EN 50014, EN 50018, and EN 50281, the product meets the fault tolerance requirements of electrical apparatus for category “d”.
- The product is an electrical apparatus and must be installed in the hazardous area in accordance with the requirements of the EC Type Examination Certificate. The installation must be carried out in accordance with all appropriate international, national and local standard codes and practices and site regulations for flameproof apparatus and in accordance with the instructions contained in the manual. Access to the circuitry must not be made during operation.
- Only trained, competent personnel may install, operate and maintain the equipment.
- The product has been designed so that the protection afforded will not be reduced due to the effects of corrosion of materials, electrical conductivity, impact strength, aging resistance or the effects of temperature variations.
- The product cannot be repaired by the user; it must be replaced by an equivalent certified product. Repairs should only be carried out by the manufacturer or by an approved repairer.
- The product must not be subjected to mechanical or thermal stresses in excess of those permitted in the certification documentation and the instruction manual.
- The product contains no exposed parts which produce surface temperature infrared, electromagnetic ionizing, or non-electrical dangers.





USA

1100 Technology Park Drive
Billerica, MA 01821-4111
Web: www.gesensing.com

Ireland

Sensing House
Shannon Free Zone East
Shannon, County Clare
Ireland

