

MR7T

Indoor Recessed Ceiling Mounted Dome Camera Enclosure

MR7T..... 7" recessed ceiling mount dome housing, tinted dome, plus (1) fixed camera bracket and decorative trim ring

MR7TL..... 7" recessed ceiling mount dome housing, tinted dome, plus (1) fixed camera bracket and decorative trim ring, includes liner; MCL 8"

MR7CL..... 7" recessed ceiling mount dome housing, clear dome, plus (1) fixed camera bracket and decorative trim ring, includes liner; MCL 8"



IMPORTANT SAFEGUARDS

- 1 Read these instructions.
- 2 Keep these instructions.
- 3 Heed all warnings.
- 4 Follow all instructions.
- 5 Do not use this apparatus near water.
- 6 Clean only with damp cloth.
- 7 Do not block any of the ventilation openings. Install in accordance with the manufacturers instructions.
- 8 Cable Runs- All cable runs must be within permissible distance.
- 9 Mounting - This unit must be properly and securely mounted to a supporting structure capable of sustaining the weight of the unit.

Accordingly:

- a. This installation should be made by a qualified service person and should conform to all local codes.
 - b. Care should be exercised to select suitable hardware to install the unit, taking into account both the composition of the mounting surface and the weight of the unit.
- 10 Do not install near any heat sources such as radiators, heat registers, stoves, or other apparatus (including amplifiers) that produce heat.
 - 11 Do not defeat the safety purpose of the polarized or grounding-type plug. A polarized plug has two blades with one wider than the other. A grounding type plug has two blades and a third grounding prong. The wide blade or the third prong are provided for your safety. When the provided plug does not fit into your outlet, consult an electrician for replacement of the obsolete outlet.
 - 12 Protect the power cord from being walked on or pinched particularly at plugs, convenience receptacles, and the point where they exit from the apparatus.
 - 13 Only use attachment/ accessories specified by the manufacturer.
 - 14 Use only with a cart, stand, tripod, bracket, or table specified by the manufacturer, or sold with the apparatus. When a cart is used, use caution when moving the cart/ apparatus combination to avoid injury from tip-over.
 - 15 Unplug this apparatus during lightning storms or when unused for long periods of time.
 - 16 Refer all servicing to qualified service personnel. Servicing is required when the apparatus has been damaged in any way, such as power-supply cord or plug is damaged, liquid has been spilled or objects have fallen into the apparatus, the apparatus has been exposed to rain or moisture, does not operate normally, or has been dropped.

Be sure to periodically examine the unit and the supporting structure to make sure that the integrity of the installation is intact. Failure to comply with the foregoing could result in the unit separating from the support structure and falling, with resultant damages or injury to anyone or anything struck by the falling unit.

UNPACKING

Unpack carefully. Electronic components can be damaged if improperly handled or dropped. If an item appears to have been damaged in shipment, replace it properly in its carton and notify the shipper.

Be sure to save:

- 1 **The shipping carton and packaging material. They are the safest material in which to make future shipments of the equipment.**
- 2 **These Installation and Operating Instructions.**

SERVICE

If technical support or service is needed, contact us at the following number:

TECHNICAL SUPPORT
AVAILABLE 24 HOURS
1 - 800 - 554 -1124

SAFETY PRECAUTIONS

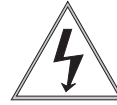
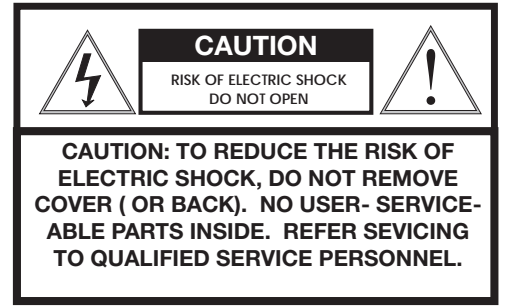

The lightning flash with an arrowhead symbol, within an equilateral triangle, is intended to alert the user to the presence of non-insulated "dangerous voltage" within the product's enclosure that may be of sufficient magnitude to constitute a risk to persons.

Este símbolo se piensa para alertar al usuario a la presencia del "voltaje peligroso no-aislado" dentro del recinto de los productos que puede ser un riesgo de choque eléctrico.

Ce symbole est prévu pour alerter l'utilisateur à la présence "de la tension dangereuse" non-isolée dans la clôture de produits qui peut être un risque de choc électrique.

Dieses Symbol soll den Benutzer zum Vorhandensein der nicht-Isolier "Gefährdungsspannung" innerhalb der Produkteinschließung alarmieren die eine Gefahr des elektrischen Schlagess sein kann.

Este símbolo é pretendido alertar o usuário à presença "di tensão perigosa non-isolada" dentro do cerco dos produtos que pode ser um risco de choque elétrico.

Questo simbolo è inteso per avvertire l'utente alla presenza "di tensione pericolosa" non-isolata all'interno della recinzione dei prodotti che può essere un rischio di scossa elettrica.



The exclamation point within an equilateral triangle is intended to alert the user to presence of important operating and maintenance (servicing) instructions in the literature accompanying the appliance.

Este símbolo del punto del exclamation se piensa para alertar al usuario a la presencia de instrucciones importantes en la literatura que acompaña la aplicación.

Ce symbole de point d'exclamation est prévu pour alerter l'utilisateur à la présence des instructions importantes dans la littérature accompagnant l'appareil.

Dieses Ausruf Punktsymbol soll den Benutzer zum Vorhandensein de wichtigen Anweisungen in der Literatur alarmieren, die das Gerät begleitet.

Este símbolo do ponto do exclamation é pretendido alertar o usuário à presença de instruções importantes na literatura que acompanha o dispositivo.

Questo simbolo del punto del exclamation è inteso per avvertire l'utente alla presenza delle istruzioni importanti nella letteratura che accompagna l'apparecchio.

**MADE IN
USA**
BUY AMERICA COMPLIANT • COUNTRY OF ORIGIN U.S.A.

Product Warranty Registration

Register Your Products Online

www.moogS3.com/technical-support/product-registration

Moog values your patronage. We are solely committed to providing you with the highest quality products and superior customer service. With 3-Year and 5-Year warranties (depending on the product purchased) we stand behind every product we sell.

See full warranty details at www.moogS3.com/technical-support/warranty-plan/

Register your products today to receive the following benefits:

- Simple and Trouble-Free RMA process
- Product / software updates
- Special promotions
- Eliminate the need to archive purchase documents such as receipts, purchase orders, etc.

Limited Warranty for Moog Products

Moog - Decatur Operations, subsequently referred to as "Manufacturer," warrants these products to be free from defects in material or workmanship as follows:

PRODUCT CATEGORY	PARTS \ LABOR
All Enclosures and Electronics	Five (5) Years
Accessory Brackets	Five (5) Years
Controllers	Three (3) Years
Power Supplies / IR Illuminators	Three (3) Years
Poles / PolEvators™ / CamEvator	Three (3) Years
Warrior Series™ / Q-View™	Three (3) Years
SView Series™	Three (3) Years 6 months if used in auto scan / tour operation
DeputyDome™, NiteTrac™, Igloo Dome, PurgeDome™	Three (3) Years 6 months if used in auto scan / tour operation
EXO Series™ Dome and Fixed Camera Systems*	Three (3) Years 6 months if used in auto scan / tour operation
EXO Series™ GeminEye Visible and Thermal Camera Systems	One (1) Year

During the labor warranty period, to repair the Product, Purchaser will either return the defective product, freight prepaid, or deliver it to Manufacturer at Moog Decatur Operations, 2525 Park Central Boulevard, Decatur, Georgia, 30035. The Product to be repaired is to be returned in either its original carton or a similar package affording an equal degree of protection with a RMA # (Return Materials Authorization number) displayed on the outer box or packing slip. To obtain a RMA# you must contact our Technical Support Team at 800.554.1124, extension 101. Manufacturer will return the repaired product freight prepaid to Purchaser. Manufacturer is not obligated to provide Purchaser with a substitute unit during the warranty period or at any time. After the applicable warranty period, Purchaser must pay all labor and/or parts charges. The limited warranty stated in these product instructions is subject to all of the following terms and conditions.

TERMS AND CONDITIONS

1. NOTIFICATION OF CLAIMS: WARRANTY SERVICE: If Purchaser believes that the Product is defective in material or workmanship, then written notice with an explanation of the claim shall be given promptly by Purchaser to Manufacturer. All claims for warranty service must be made within the warranty period. If after investigation, Manufacturer determines the reported problem was not covered by the warranty, Purchaser shall pay Manufacturer for the cost of investigating the problem at its then prevailing per incident billable rate. No repair or replacement of any Product or part thereof shall extend the warranty period of the entire Product. The specific warranty on the repaired part only shall be in effect for a period of ninety (90) days following the repair or replacement of that part or the remaining period of the Product parts warranty, whichever is greater.

2. EXCLUSIVE REMEDY: ACCEPTANCE: Purchaser's exclusive remedy and Manufacturer's sole obligation is to supply (or pay for) all labor necessary to repair any Product found to be defective within the warranty period and to supply, at no extra charge, new or rebuilt replacements for defective parts.

3. EXCEPTIONS TO LIMITED WARRANTY: Manufacturer shall have no liability or obligation to Purchaser with respect to any Product requiring service during the warranty period which is subjected to any of the following: abuse, improper use, negligence, accident, or acts of God (i.e., hurricanes, earthquakes), modification, failure of the end-user to follow the directions outlined in the product instructions, failure of the end-user to follow the maintenance procedures recommended by the International Security Industry Organization, written in product instructions, or recommended in the service manual for the Product. Furthermore, Manufacturer shall have no liability where a schedule is specified for regular replacement or maintenance or cleaning of certain parts (based on usage) and the end-user has failed to follow such schedule; attempted repair by non-qualified personnel; operation of the Product outside of the published environmental and electrical parameters, or if such Product's original identification (trademark, serial number) markings have been defaced, altered, or removed. Manufacturer excludes from warranty coverage Products sold AS IS and/or WITH ALL FAULTS and excludes used Products which have not been sold by Manufacturer to the Purchaser. All software and accompanying documentation furnished with, or as part of the Product is furnished "AS IS" (i.e., without any warranty of any kind), except where expressly provided otherwise in any documentation or license agreement furnished with the Product. ANY COST ASSOCIATED WITH REMOVAL OF DEFECTIVE PRODUCT AND INSTALLATION OF REPLACEMENT PRODUCT IS NOT INCLUDED IN THIS WARRANTY.

4. PROOF OF PURCHASE: The Purchaser's dated bill of sale must be retained as evidence of the date of purchase and to establish warranty eligibility.

DISCLAIMER OF WARRANTY

EXCEPT FOR THE FOREGOING WARRANTIES, MANUFACTURER HEREBY DISCLAIMS AND EXCLUDES ALL OTHER WARRANTIES, EXPRESS OR IMPLIED, INCLUDING, BUT NOT LIMITED TO ANY AND/OR ALL IMPLIED WARRANTIES OF MERCHANTABILITY, FITNESS FOR A PARTICULAR PURPOSE AND/OR ANY WARRANTY WITH REGARD TO ANY CLAIM OF INFRINGEMENT THAT MAY BE PROVIDED IN SECTION 2-312(3) OF THE UNIFORM COMMERCIAL CODE AND/OR IN ANY OTHER COMPARABLE STATE STATUTE. MANUFACTURER HEREBY DISCLAIMS ANY REPRESENTATIONS OR WARRANTY THAT THE PRODUCT IS COMPATIBLE WITH ANY COMBINATION OF NON-MANUFACTURER PRODUCTS OR NON-MANUFACTURER RECOMMENDED PRODUCTS PURCHASER MAY CHOOSE TO CONNECT TO THE PRODUCT.

LIMITATION OF LIABILITY

THE LIABILITY OF Manufacturer, IF ANY, AND PURCHASER'S SOLE AND EXCLUSIVE REMEDY FOR DAMAGES FOR ANY CLAIM OF ANY KIND WHATSOEVER, REGARDLESS OF THE LEGAL THEORY AND WHETHER ARISING IN TORT OR CONTRACT, SHALL NOT BE GREATER THAN THE ACTUAL PURCHASE PRICE OF THE PRODUCT WITH RESPECT TO WHICH SUCH CLAIM IS MADE. IN NO EVENT SHALL MANUFACTURER BE LIABLE TO PURCHASER FOR ANY SPECIAL, INDIRECT, INCIDENTAL, OR CONSEQUENTIAL DAMAGES OF ANY KIND INCLUDING, BUT NOT LIMITED TO, COMPENSATION, REPLACEMENT LABOR COSTS, REIMBURSEMENT, OR DAMAGES ON ACCOUNT OF THE LOSS OF PRESENT OR PROSPECTIVE PROFITS OR FOR ANY OTHER REASON WHATSOEVER.



Electrical Specifications

MR7T



English

No power options provided.
Power required for camera only.
Power 24VAC
Class 2 Power Supply Only
Tools Required: Phillips Head Screwdriver
Ceiling Support Wires(18-24 Gauge Wire)



Español

Ningunas opciones de la energía proporcionaron. Energía requerida para la cámara fotográfica solamente.
Energía 24VAC
Fuente De Alimentación De la Clase 2 Solamente
Herramientas Requeridas: Destornillador Principal Phillips
Alambre De la Galga De la Ayuda Wires(18-24 Del Techo)



Français

Option de puissance n'a pas fourni.
Puissance requise pour l'appareil-photo seulement.
Puissance 24VAC
Alimentation D'Énergie De la Classe 2 Seulement.
Outils Requis : Tournevis Principal Phillips
Fil De Mesure De Soutien Wires (18-24 De Plafond)



Deutsch

Keine Energie Wahlen stellten zur Verfügung.
Energie erfordert für nur Kamera.
Energie 24VAC
Nur Kategorie 2 Spg.Versorgungsteil
Werkzeuge Erfordert:
Kreuzkopfhauptschraubenzieher
Decke Unterstützungswires
(18-24 Lehre Leitung)



Portuguese

Nenhumas opções do poder fornecidas.
Poder requerido para a câmara somente.
Poder 24VAC
Fonte De Alimentação Da Classe 2 Somente
Ferramentas Requeridas: Chave de fenda Principal Phillips
Fio Do Calibre Da Sustentação Wires(18-24 Do Teto)



Italiano

Nessun'opzione di alimentazione ha fornito.
Alimentazione richiesta per la macchina fotografica soltanto.
Alimentazione 24VAC
Gruppo di alimentazione Del Codice categoria 2 Soltanto
Gli Attrezzi Hanno richiesto: Cacciavite Capo "phillips"
Legare Del Calibro Di Sostegno Wires(18-24 Del Soffitto)

Content of Box

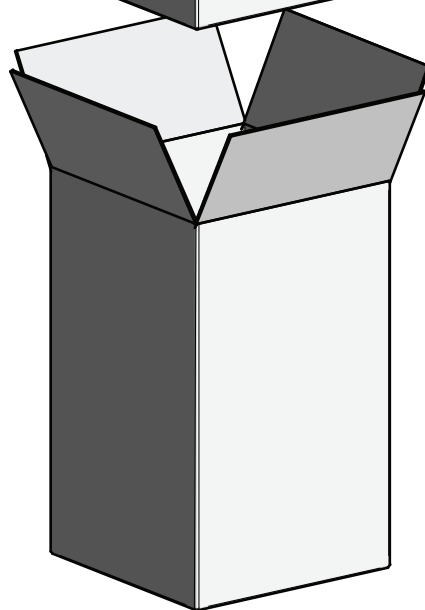
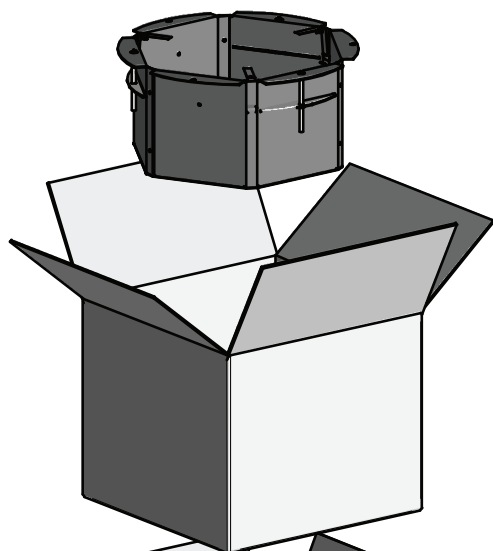
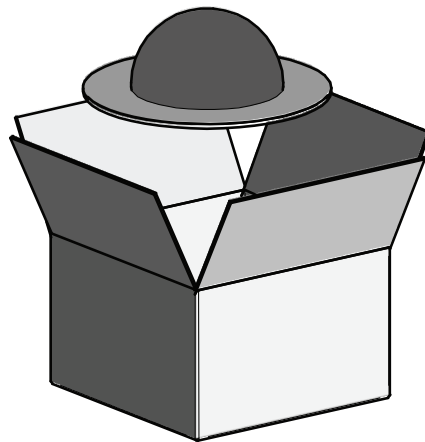

1

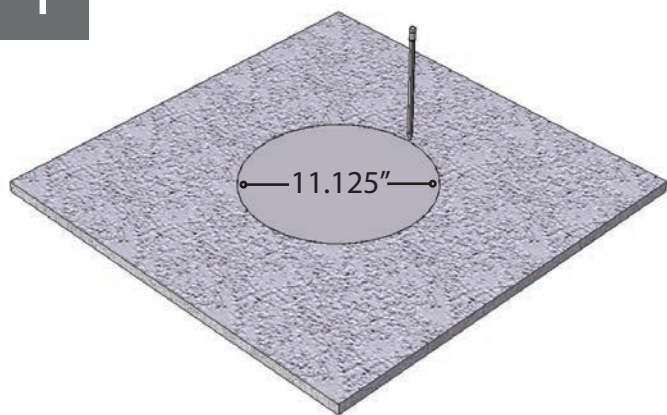

Using the provided template, mark the ceiling tile for the cutout.

- Con la plantilla proporcionada, cortar el azulejo del techo para el agujero.
- En utilisant le calibre fourni, marquez la tuile de plafond pour le coupe-circuit.
- Mit der zur Verfügung gestellten Schablone kennzeichnen Sie die Decke Fliese für den Ausschnitt.
- Usando o molde fornecido, marque a telha do teto para o entalhe.
- Usando la mascherina fornita, contrassegni le mattonelle del soffitto per il ritaglio.

2

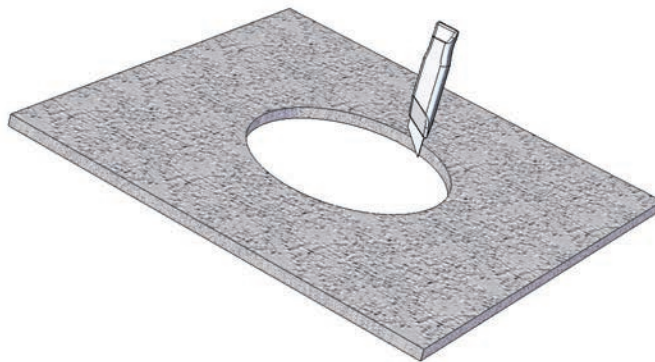

A box cutter or jigsaw can be used for cutting the circle.

- Un cortador o un rompecabezas de la caja se puede utilizar para cortar el círculo.
- Un coupeur ou une scie sauteuse de boîte peut être utilisé pour couper le cercle.
- Ein Kastenscherblock oder -tischlerbandsäge können für den Schnitt des Kreises benutzt werden.
- Um cortador ou um jigsaw da caixa podem ser usados cortando o círculo.
- Una taglierina o un jigsaw della scatola può essere utilizzato per il taglio del cerchio.

3

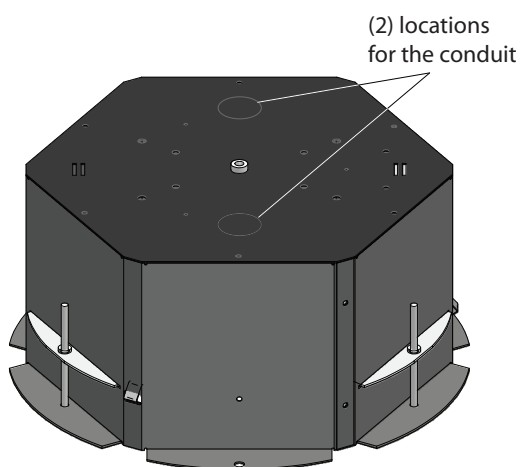

Remove the desired conduit knock-out from the top of the housing.

- Quite la maravilla deseada del conducto de la tapa de la cubierta.
- Enlevez l'éjecteur désiré de conduit du dessus du logement.
- Entfernen Sie den gewünschten Rohr Knock-out von der Oberseite des Gehäuses.
- Remova o knock-out desejado da canalização do alto da carcaça.
- Rimuova l'espulsore voluto del condotto dalla parte superiore dell'alloggiamento.

4

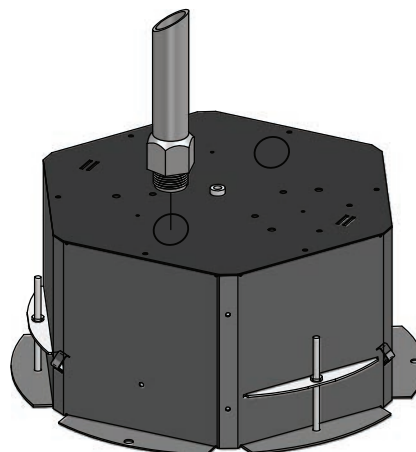

Fit the flex conduit or 'L' conduit into the desired hole.

- Quepa el conducto o el 'L' conduit de la flexión en el agujero deseado.
- Adaptez le conduit ou le 'L' conduit de câble dans le trou désiré.
- Passen Sie das Flexrohr oder das 'L' conduit in die gewünschte Bohrung.
- Caiba a canalização do cabo flexível ou o 'L' conduit no furo desejado.
- Misura il condotto della flessione o il 'L' conduit nel foro voluto.

5

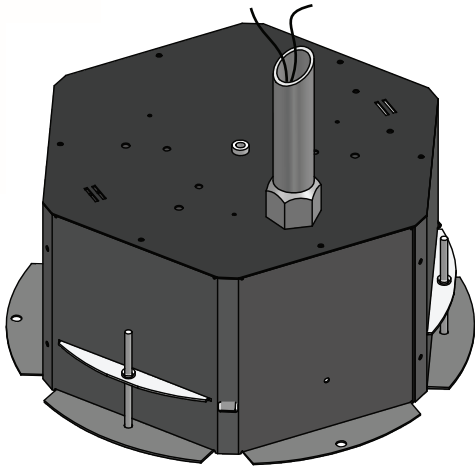

Run electrical cable into the housing through the conduit.

- Funcione el cable eléctrico en la cubierta a través del conducto.
- Courez le câble électrique dans le logement par le conduit.
- Lassen Sie elektrisches Kabel in das Gehäuse durch das Rohr laufen.
- Funcione o cabo elétrico na carcaça através da canalização.
- Faccia funzionare il cavo elettrico nell'alloggiamento tramite il condotto.

6

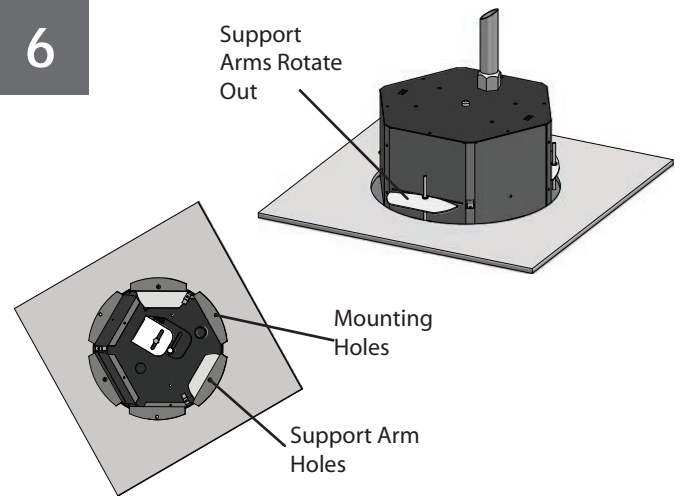

With the bottom flange pressed against the ceiling, rotate support arms to the outside. Tighten the support arm screws.

- Con el fondo el reborde presionó contra el techo, rota los brazos de ayuda al exterior. Apriete los tornillos del brazo de ayuda.
- Avec le fond la bride a serré contre le plafond, tourment des bras de soutien jusqu'à l'extérieur. Serrez les vis de soutien.
- Mit Unterseite betätigte sich der Flansch gegen die Decke, drehen Lagerarme zur Außenseite. Ziehen Sie die Lagerarmschrauben fest.
- Com fundo a flange pressionou de encontro ao teto, gira os braços de sustentação à parte externa. Aperte os parafusos do braço de sustentação.
- Con la parte inferiore la flangia ha premuto contro il soffitto, ruota l'armi di sostegno alla parte esterna. Stringa le viti del braccio di sostegno.

7

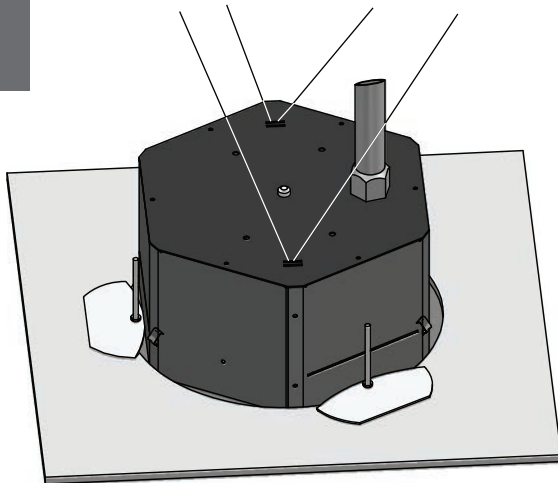

If required, secure housing by running bolts in the bottom flange and support wires from a solid structure.

- Si está requerido, asegure los pernos del funcionamiento de la cubierta en el reborde inferior y apoye los alambres de una estructura sólida.
- S'il y a lieu, fixez les boulons de course de logement dans la bride inférieure et soutenez les fils d'une structure pleine.
- Wenn erforderlich sichern Sie Gehäusedurchlaufschaubolzen im unteren Flansch und stützen Sie Leitungen von einer festen Struktur.
- Se requerido, fixe os parafusos do funcionamento da carcaça na flange inferior e suporte fios de uma estrutura contínua.
- A richiesta, assicuri i bulloni di funzionamento dell'alloggiamento nella flangia inferiore e sostenga i legare da una struttura solida.

8

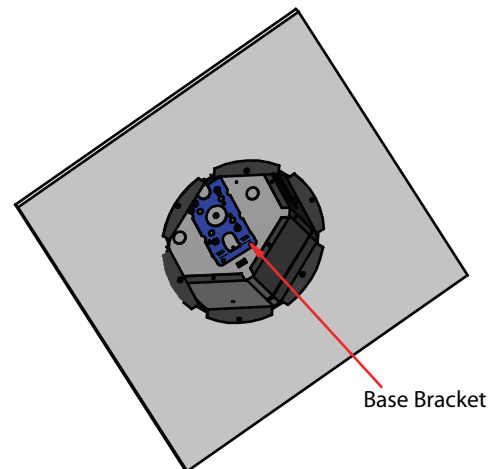

The camera may be mounted on either side of the tilted part of the camera bracket.

- La cámara fotográfica se puede montar de cualquier lado de la pieza inclinada del soporte de la cámara fotográfica.
- L'appareil-photo peut être monté de chaque côté de la pièce inclinée de la parenthèse d'appareil-photo.
- Die Kamera kann vom gekippten Teil des Kamerahaltewinkels auf beiden Seiten angebracht werden.
- A câmera pode ser montada em um ou outro lado da peça inclinada do suporte da câmera.
- La macchina fotografica può essere montata da qualsiasi lato della parte inclinata della staffa della macchina fotografica.

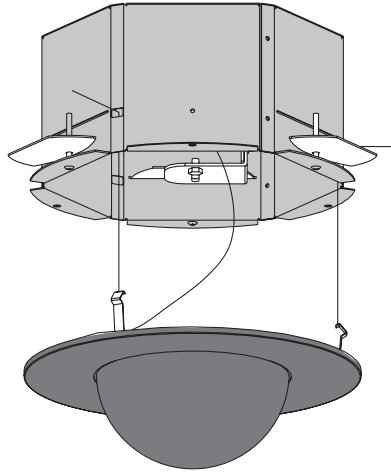

Reattach the trim ring/ dome assembly by pressing in and sliding (3) springs in the housing.

- Reate el montaje de la bóveda del anillo del ajuste clavando y resbalando (3) los resortes en la cubierta.
- Rattachez le dôme d'anneau d'équilibre en enfonçant et diapositive (3) des ressorts dans le logement.
- Befestigen Sie die Ordnung Ringhaube wieder, indem Sie (3) Federn im Gehäuse eindrücken und schieben.
- Reate o conjunto da abóbada do anel da guarnição pressionando dentro e deslizando (3) as molas na carcaça.
- Riattacci il complessivo della cupola dell'anello della cornice introducendo e diapositiva (3) le molle nell'alloggiamento.

Replacement Parts List

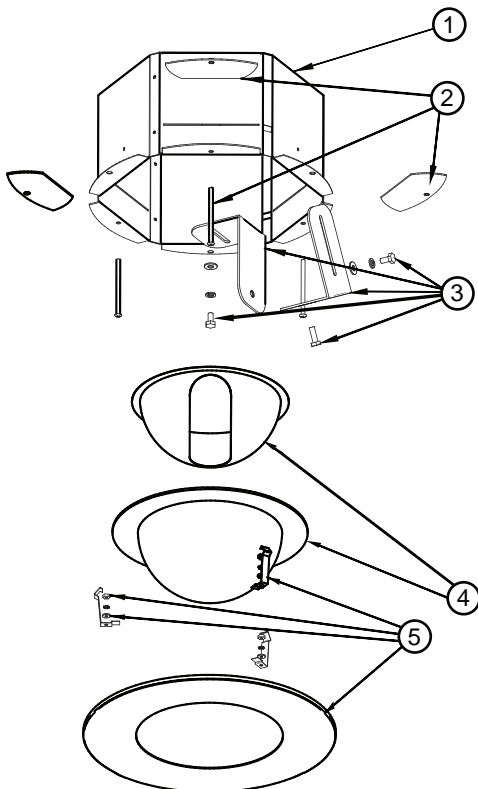

MR7T
MR7TL
MR7CL

Part Number	Description
1	RPMR7010 HOUSING ASSEMBLY
2	RPMR7020 SUPPORT ARMS KIT
3	N/A
4	RQMR7T REPLACEMENT CAPSULE FOR MR7T HOUSING
	RQMR7C REPLACEMENT CAPSULE FOR MR7CL HOUSING, NO SILKSCREEN, LINER
5	RPMR7050 WHITE TRIM RING ASSEMBLY