

Fellowes





ENGLISH



FRANÇAIS

ESPAÑOL

HRL 95

					
	850 mhz 3 mil	1000 mhz 4 mil	1000 mhz 5 mil	1700 mhz 5 mil	2000 mhz 10 mil
70-100 g 20-23 Sec	1	2	2	3	4
110-150 g 30-42 Sec	2	3	3	3	A5 4
170-240 g 44-53 Sec	3	4	4		
250-300 g 55-60 Sec	4	4	4		

HRL 125

					
	850 mhz 3 mil	1000 mhz 4 mil	1000 mhz 5 mil	1700 mhz 5 mil	2000 mhz 10 mil
70-100 g 20-23 Sec	1	2	2	3	4
110-150 g 30-42 Sec	2	3	3	3	A4 4
170-240 g 44-53 Sec	3	4	4		
250-300 g 55-60 Sec	4	4	4		

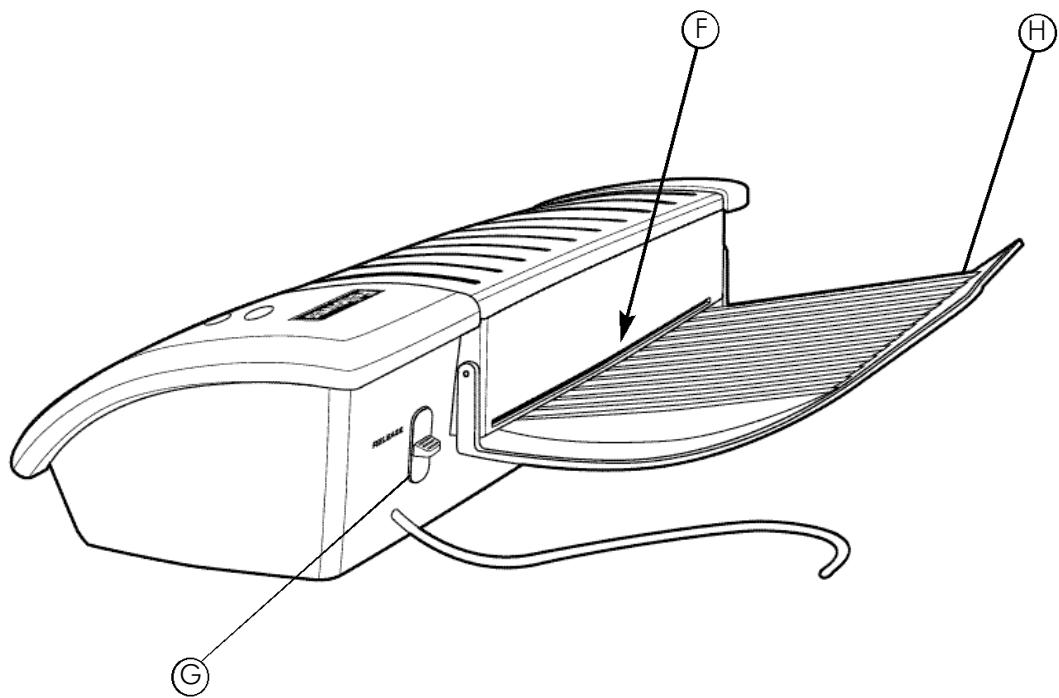
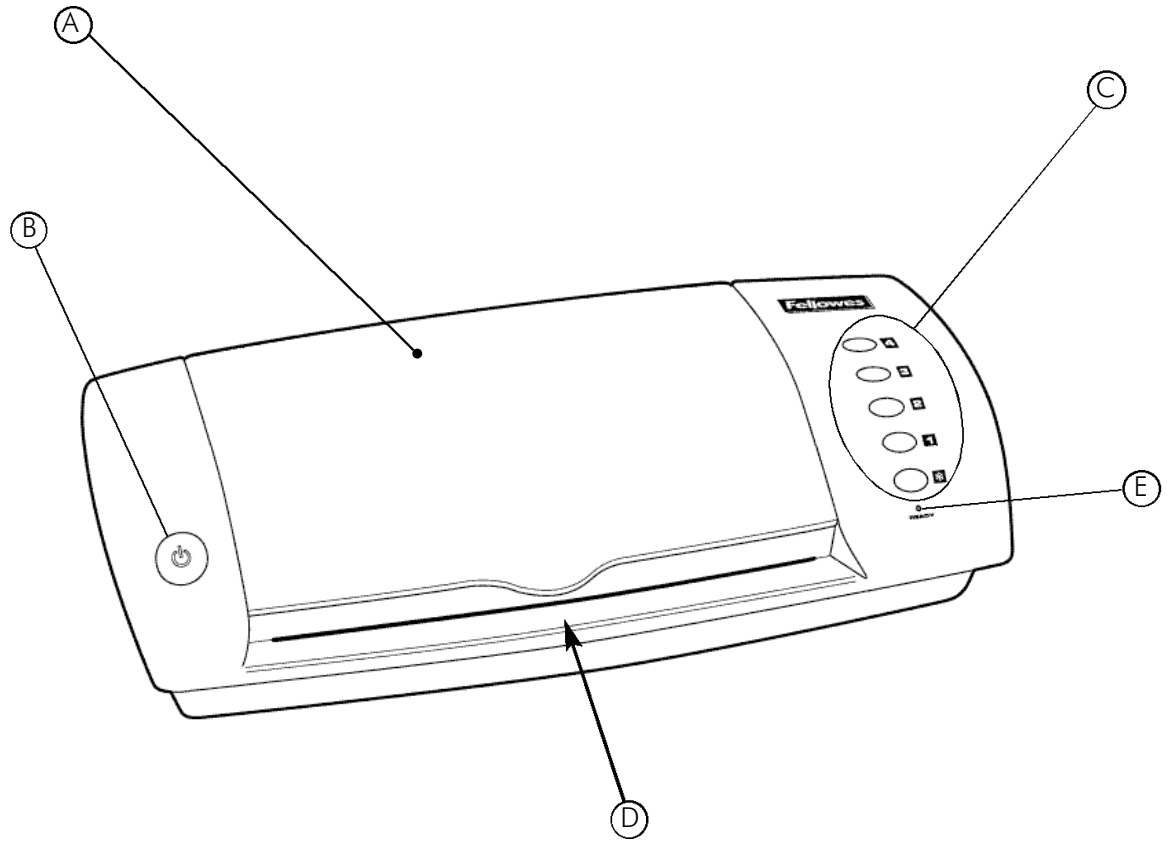

Fellowes

Dear Customer,

Thank you for buying a Fellowes laminator. This product represents a new generation of laminators, products that are not only good-looking, but also considerably smarter and more hardworking. This means more laminating options, faster processing, greater ease of use, and more professional results. We know of no laminators on the market today that offer you more value for your money in this product category.

To ensure that your laminator enjoys a long, productive life, I hope you take the time to read the few pages of this manual. If you have any questions or wish to comment on this product, we welcome your call, email or letter.

Sincerely,

*James Fellowes
Chairman & CEO*

Contents

Product Profile	3
Safety Instructions	4
Set-up	4
Operation	4
Maintenance	7
Troubleshooting	7
Customer Service	8
Limited Warranty	8

Product Profile

The HRL 95 and the HRL 125 are **medium-duty** laminating machines designed for those who laminate often, either at home or at the office. Both allow you to enjoy many of the advantages of large office laminators, while paying only for the capacity you need. Both are also fully **photo-capable**, meaning that you can easily laminate not only professionally processed pictures, but digital photos you print yourself as well.



With this new generation, we have also built in more **capacity, speed** and **user-friendliness**:

OVERVIEW	HRL 95	HRL 125
Capacity		
<i>-Pouch width</i>		
DIN size	A4	A3
centimeters	24	33
inches	9	12
<i>-Pouch thickness : min-max</i>		
microns	80-250	80-250
mils	3-10	3-10
<i>-Paper thickness : max</i>		
grams	300	300
lbs	80	80
sheet equivalent*	4	4
<i>-Combined thickness : max</i>		
millimeters	0,8	0,8
inches	1/32	1/32
sheet equivalent*	8	8
Warm-up time in minutes :		
- 1	4	4
- 2	+3	+3
- 3	+2'30	+2'30
- 4	+2'30	+2'30
Processing time in seconds**		
	42	42
Temperature Options		
	1 cold, 4 hot	1 cold, 4 hot
Motor release Switch	✓	✓
Automatic Switch-off	✓	✓
Audible Ready Signal	✓	✓

* Standard office paper (20 lb / 75g)

** One A4/letter-size pouch

For **best results**, always try to stay within the above capacity limits. Exceeding them may reduce the quality of your work and, in extreme cases, damage your machine.

IMPORTANT SAFETY INSTRUCTIONS

READ ALL INSTRUCTIONS BEFORE USING

Treat your laminator as you would any other piece of electrical equipment:

- Keep it away from heat or water sources
- Plug it in near an easily accessible outlet
- Do not use if it is damaged in any way
- Do not attempt to open or otherwise repair it
- Turn it off after each use, and
- Unplug it when not in use for an extended period.

Set-up

HRL laminators come fully assembled and ready to use.

Operation

Your laminator works by means of four rubberized rollers, two above and two below, each pair turning in the opposite direction to draw an adhesive-coated, open-sided plastic pouch through the machine. Understanding this mechanism will help you decide what materials you **can laminate** without risk of damage to your machine. You can feel confident laminating all materials that are **flat and dry**, for example, but should avoid those that:

- Contain liquids, gels, or even moisture that could escape
- May crumble or otherwise disperse under pressure, or
- Are likely to break, like glass or rigid metals and plastics.

With hot lamination, also make sure not to put anything into the pouch that could melt and leak into the machine.

Assuming suitable contents, the question is whether to laminate them in the **hot or cold** mode. The key advantage of hot lamination is that it creates a tighter seal than cold, which bonds solely by pressure on an adhesive surface. With the new technology built into your machine, you can also now use the hot mode to laminate photographs of all kinds. Cold lamination, however, is still the better choice if your contents are heat-sensitive, like thermal paper.

With the contents and the mode decided, the next step is to **choose the right pouch**. Hot and cold laminating pouches are especially designed for their separate purposes and cannot be substituted for one another. When it comes to pouch size, each model has a different maximum: DIN A4, or 9 inches (22,9 cm), for the HRL 95 and DIN A3, or 12 inches (30,5 cm), for the HRL 125. As for pouch thickness, if you are laminating paper of a standard size and weight, you may have a number of options. Using the illustration on the inside of the manual cover as a reference, lift back the cover **A** of your machine and look for your paper/pouch combination on the guide printed inside:

- *Numbered boxes* indicate that you can laminate the combination,
- *Empty or missing boxes* indicate that you should not attempt it with your model.

If you see more than one option, take the thickness that **best suits your purpose**: The thicker the pouch, the more rigid and wear-resistant the laminated sheet will be.

If you are not sure of the paper's weight or are laminating **materials other than paper**, the combined thickness of the pouch and contents should be your guide. The maximum in this case is the equivalent of a stack of 8 sheets of standard office paper. (See *Product Profile*.)

To ensure **high-quality results**, always:

- **Leave a free margin** around the contents of at least 3 mm, or 1/8 inch, on the three unsealed sides of the pouch. This will guarantee a strong seal. If you put more than one item in the pouch and want to cut them out individually, make sure you have at least 6 mm, or 1/4 inch, between them.
- **Cut to size only after lamination.** If even a small pouch will leave too much space around your contents or if you want the lamination to conform to their shape, wait until they are laminated before cutting: A laminating pouch is precision-cut to ensure minimal leakage of adhesives, and this cannot be replicated with scissors or paper-cutters. You'll also find the pouch easier to cut afterwards.

To begin laminating, plug in the machine, lift back the cover **Ⓐ** and press the power button **Ⓑ**, which will start the rollers turning. Make sure you have enough space behind the laminator to open the cover completely because it will operate only when the cover is in this position **Ⓗ**. (This safeguard ensures adequate motor ventilation, while providing support for sheets as they exit the machine.)

If you plan to laminate in both the cold and hot modes in one session, **start with cold**, so you don't have to wait one to two hours for the machine to cool down. In either case, to save energy and reduce wear-and-tear on your machine, turn off the machine when you're finished, again pressing the power button. If you forget, the machine will **switch itself off** automatically after one hour of inactivity.

Cold Lamination

With the contents and the pouch you have selected at hand:

1. **Press **ⓧ**, if necessary.** Your machine will be on this setting when you turn it on, so if it is at room temperature, you will almost immediately see the green standby light **Ⓒ** go on and hear the ready signal.
2. **Open pouch and place contents face up** onto the transparent, non-adhesive side, allowing for the 3 mm, or 1/8 inch, free margin. Leave the pouch open, with the adhesive side, which is covered by a glossy protective sheet, upright.

3. **Insert full length of sealed edge** into the pouch entry ⑩, as shown, while bending the protective sheet backwards over the machine and grasping its free edge. As the machine draws in the pouch, continue holding the protective sheet, which will be peeled away from the adhesive side as the pouch moves through. (Although it's easier to remove the protective sheet and close the pouch beforehand, this creates air bubbles and other irregularities.)

If you did not get the pouch in straight and it might get damaged, you can fix this easily by turning off the machine and following the instructions in *Troubleshooting*.

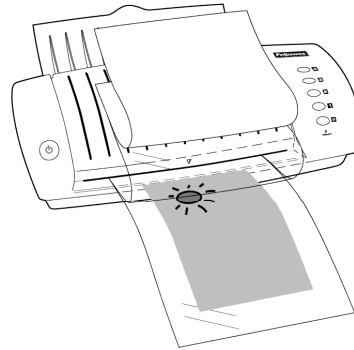

The finished sheet will emerge from the sheet exit ⑪ by itself. Remove it from the open cover only after it has completely cleared the exit.

Hot lamination

With the contents and the pouch you have selected at hand:

1. **Select temperature.** The guide on pouch thickness for standard paper sizes and weights also indicates recommended temperature settings. The numbers in the boxes stand for the intensity of heat, with **1** for the lowest and **4** for the highest. Press the indicated temperature button ⑬ and wait until you see the green standby light ⑭ go on and hear the ready signal. (Warm-up takes 4 minutes for the lowest setting and 12 minutes for the highest.) With pouches containing non-standard paper or other materials, where it is hard to tell exactly how much thinner they are than the 8-sheet maximum, start with a lower setting. If the pouch comes out cloudy, a sign of insufficient heat, you can always put it through again or raise the temperature.
2. **Open pouch and place contents inside,** allowing for the 3 mm, or 1/8 inch, free margin. Unlike with cold laminating, the contents can be either face up or face down within the pouch. Close the pouch once you have arranged the contents.
3. **Insert full length of sealed edge** into the pouch entry ⑩, as shown, and release it as soon as the machine begins to draw it in. If you did not get the pouch in straight and it might get damaged, you can fix this easily by turning off the machine and following the instructions in *Troubleshooting*.

The finished sheet will emerge from the sheet exit ⑪ by itself. Remove it from the open cover only after it has completely cleared the exit.

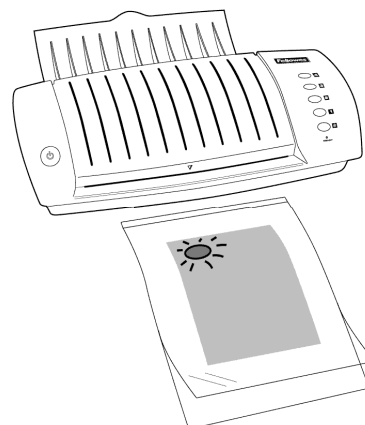

Maintenance

To keep your laminator free of adhesives that could hurt the quality of your work, you should **clean the rollers** from time to time, or frequently, depending on how often you use the machine. The best way is to do this right after you have finished hot laminating, because the rollers will still be hot, which is necessary for the cleaning process.

To clean the rollers:

- Press temperature button **4** if it is not already on this setting
- Wait for the readiness light and signal, if necessary
- Insert the cleaning sheet included in the package, repeating one or two times
- Insert a plain white sheet of paper to test for remaining traces, and
- Reinsert the cleaning sheet, if necessary, and retest.

To clean the exterior of your machine, just wipe with a soft cloth dampened with plain water.

Troubleshooting

If the motor **does not start at all** when you press the power button, it is most likely because the cover is not completely open. Check behind the machine to make sure nothing is in the way.

If you are **not getting the quality** you should be, you can probably solve the problem quickly. If, for example, your end product is:

- **Cloudy** – The temperature is too low or the filled pouch too thick. Try passing it through the machine one or more times, or raising the temperature if you can. Otherwise, choose a thinner pouch or reduce the weight or thickness of the contents.
- **Wavy** – The temperature is too high. Turn the machine to the lower setting. Passing through the cleaning sheet will help cool down the rollers and reduce the amount of time you have to wait.
- **Spotted** – The rollers have deposits of adhesive. Follow the cleaning procedure, as described under *Maintenance*.
- **Open on edges** – Your contents are too close to the edge of the pouch to create a strong seal. Next time make sure your contents are at least 3 mm, or 1/8 inch, from the unsealed edges of the pouch.

If a pouch is **not going in straight** or gets **stuck in the rollers**, you can realign or remove it as follows: Turn off the machine, then press and slide the motor release button **ⓐ** over and up to the higher position, as shown at the right. This will disengage the roller drive, enabling you to adjust the pouch or pull it back out of the entry. Press and slide the button back to its original position to continue laminating.

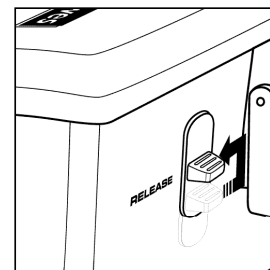

If you have questions or problems with your laminator that you cannot solve, please contact us through one of the many channels listed under *Customer Service*.

SAFETY REMINDER: Do not attempt to open or otherwise repair your machine.

Customer Service

Fellowes offers a **toll-free help line** for customers living in the United States, Canada, Mexico and Australia. If you live outside of these regions or are otherwise unable to use our help line, please call the Fellowes location nearest you, send us a letter or email, or contact your local dealer. All of our customer service phone numbers and other points of contact are listed on the back of this manual.

Limited Warranty

Fellowes warrants all parts of the machine to be free of defects in material and workmanship for **1 year** from the date of purchase by the original consumer. If any part is found to be defective during the warranty period, your sole and exclusive remedy will be repair or replacement, at Fellowes' option and expense, of the defective part.

This warranty does not apply in cases of abuse, mishandling or unauthorized repair. ANY IMPLIED WARRANTY, INCLUDING THAT OF MERCHANTABILITY OR FITNESS FOR A PARTICULAR PURPOSE, IS HEREBY LIMITED IN DURATION TO THE APPROPRIATE WARRANTY PERIOD SET FORTH ABOVE. IN NO EVENT SHALL FELLOWES BE LIABLE FOR ANY CONSEQUENTIAL OR INCIDENTAL DAMAGES ATTRIBUTABLE TO THIS PRODUCT. This warranty gives you specific legal rights. You may have other legal rights that vary from this warranty. The duration, terms and conditions of this warranty are valid worldwide, except where different limitations, restrictions or conditions may be required by local law.

For more details or to obtain service under this warranty, please contact us or your dealer.

Help Line

Australia	+ 1-800-33-11-77
Canada	+ 1-800-665-4339
México	+ 1-800-234-1185
United States	+ 1-800-955-0959

Fellowes

Australia	+ 61-3-8336-9700
Benelux	+ 31-(0)-347-377988
Canada	+ 1-905-475-6320
Deutschland	+ 49-(0)-5131-49770
France	+ 33-(0)-1-30-06-86-80
Italia	+ 39-(0)-71-730041
Japan	+ 81-(0)-3-5496-2401
Korea	+ 82-(0)-2-3462-2884
Malaysia	+ 60-(0)-35122-1231
Polska	+ 48-(0)-22-837-7356
Singapore	+ 65-6221-3811
United Kingdom	+ 44-(0)-1302-836836

www.fellowes.com