

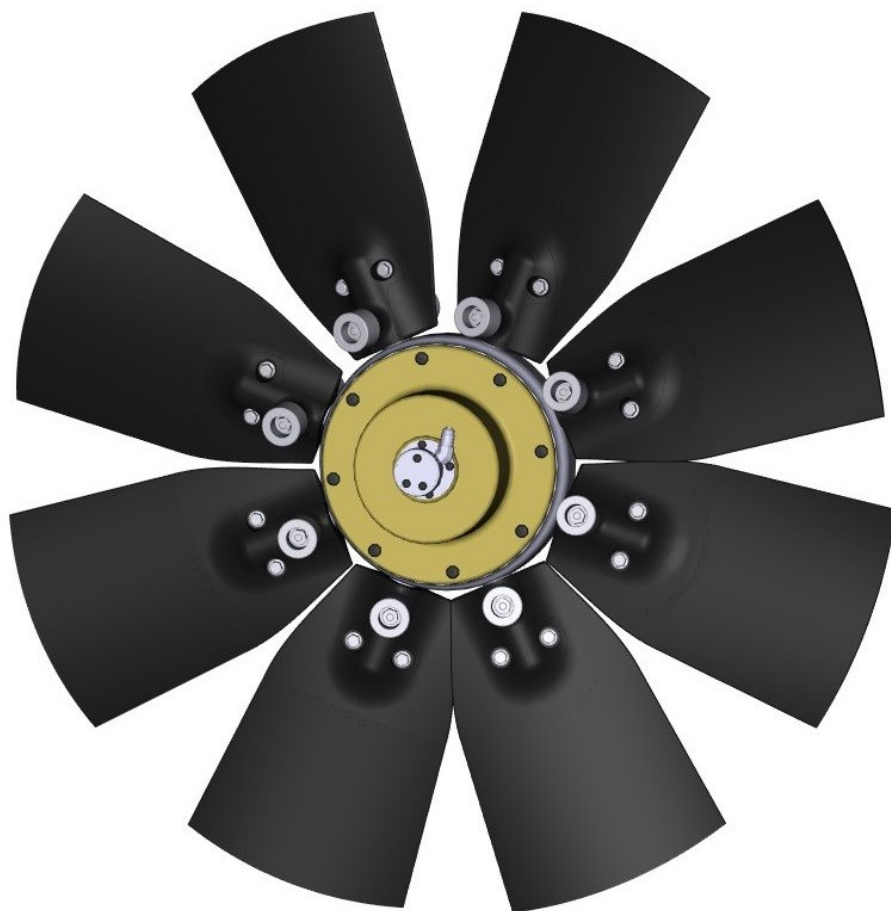

FLEXXAIRE

**INSTALLATION AND SERVICE MANUAL
FOR THE
SERIES 2000 & SERIES 3000 FAN SERIES
GEN 2
(PNEUMATIC CONTROL AND HYDRAULIC CONTROL)**



PUBLICATION No. 01900
Revision 1

Printed in Canada

1.1 INTRODUCTION

Thank you for purchasing a Flexxaire Fan System.

Flexxaire takes great pride in designing, manufacturing and assembling its products for many years of use.

This manual (**P/N 01900**) is produced to assist in the installation, operation and maintenance of the GEN 2 Flexxaire® Series 2000 and Series 3000 Fan Systems using Pneumatic or Hydraulic actuation.

Flexxaire has made every effort to ensure that the information contained in this manual is correct and complete at the time of printing. Flexxaire will assume no responsibility for any errors or omissions. If you have any questions regarding this manual, any other document provided with your fan system or any questions not answered by this manual, please contact:

Flexxaire Inc.

Product Support Department

10430-180 Street

Edmonton, Alberta, Canada

T5S-1C3

Phone: 780-483-3267

Fax: 780-483-6099

Monday to Friday 7:00 am to 3:30 pm MST

1.2 IMPORTANT SAFETY INFORMATION

The safety information in this publication is to be used in conjunction with the safety information supplied from the original machine manufacturer. Please refer to all safety information supplied, prior to doing any work on the fan assembly or any other component to assure safety.

Improper operation, maintenance or repair of this product can be dangerous and could result in injury or death.

Always use Genuine Flexxaire parts and components or Flexxaire approved parts and components. The use of unapproved parts and/or components will void the 1-year warranty.

Do not operate or perform any maintenance on this product until you have read and understand the operation and maintenance information. Please contact Flexxaire or an approved dealer for any information that you may require.

The person(s) servicing the product may be unfamiliar with many of the systems or components on the product. It is important to use caution when performing any type of service work. Knowledge of the product and/or its components is important before the removal or disassembly of any component.

1.2.1 PROTECTIVE EQUIPMENT

Always wear protective glasses, protective shoes and any other protective equipment as required by law and/or your company safety program.

1.2.2 PRESSURIZED FAN HUB

The hub assembly is spring loaded. If disassembly of the hub is required, take caution that you are well protected from the hub's release which may be sudden and pose an impact related injury.

Also make sure that the internal pressure is released. Consult the pneumatic or hydraulic control instructions in this manual.

1.2.3 HOT FLUIDS AND PARTS

To avoid burns, be alert for hot parts on the assembly or the machine that have just been stopped and have hot fluid in lines, tubes and compartments.

1.3 FAN SPECIFICATIONS

The following needs to be considered prior to the installation of the Flexxaire Fan System. If your situation is listed in this section, **DO NOT INSTALL THE FAN.** Damage and/or injury may occur.

1.3.1 MOUNTING

WARNING: This fan is not designed to be mounted onto a crank shaft or crank shaft pulley. Torsional vibration from crankshafts will damage the fan and could result in machine damage and serious injury.

1.3.2 FAN BLADE TIP SPEED

WARNING: The fan system must not exceed a blade tip speed of 20,000 feet/minute. Exceeding this speed may cause damage to and/or failure of the fan, which in turn may cause injury or death, or damage to the radiator and surrounding equipment.

To calculate the blade tip speed, use the following formula:

$$\text{Fan Diameter (Inches)} \times 3.14 \times \text{Fan RPM}$$

12

If your calculated tip speed exceeds 20,000 ft/min, contact Flexxaire directly, prior to installation. **It is important to use Fan RPM and NOT engine RPM.**

1.4 FAN OVERVIEW

Flexxaire's Series 2000/3000 fan systems are designed to minimize overheating caused by debris plugged radiators, screens and guards, and reduce overcooling in low ambient temperatures. The blades of the Series 2000/ Series 3000 vary pitch, not speed, to control air flow volume and direction.

How your Series 2000/ Series 3000 works:

The Series 2000/ Series 3000 can be purchased as a pneumatically actuated variable pitch fan or hydraulically actuated variable pitch fan. The blades are held in full pitch by a heavy spring. As pneumatic (or hydraulic) pressure is applied to the control line, the pitch of the blade is reduced and then reversed. When the pressure is released, the fan blades return to their default position.

The Series 2000/ Series 3000 fan has a number of important features:

1. **Fail Safe Operation:** The blades are spring loaded into the default full pitch position. If the fan loses pressure, the fan will default to full pitch and act like a fixed pitch fan giving maximum cooling.
2. Depending on the control kit ordered (see Section 2.0), the fan can be run in a neutral pitch (or any pitch in between) to solve overcooling problems and save horsepower and fuel.
3. When purging, there are no horsepower spikes, in fact, the horsepower drops off as you pass through neutral pitch, then slowly builds as pitch increases.

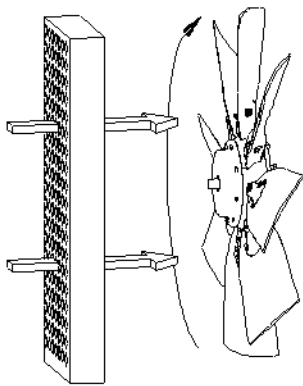

NORMAL OPERATION

EFFICIENT COOLING

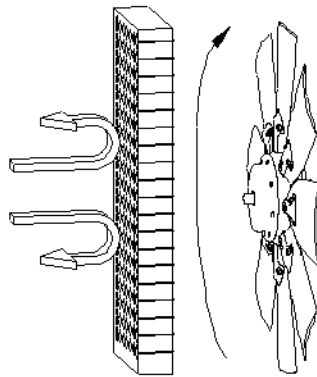

NEUTRAL PITCH

STOP AIR FLOW
PREVENT OVERCOOLING
SAVE HORSEPOWER

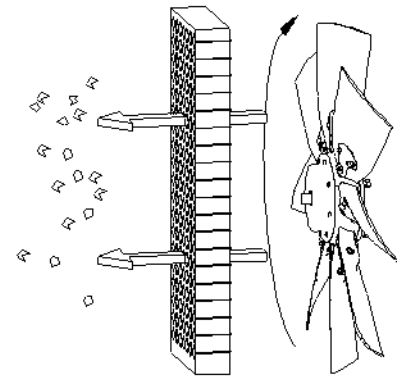

PURGE

CLEAN RADIATOR
PREVENT OVERHEATING

2.0 CONTROL KITS

Due to the variability of machines that the Series 2000/ Series 3000 fan may be installed on, the fan does not include any control components. Flexxaire has a number of different control kits available to suit a wide range of applications:

PNEUMATIC CONTROL:

- 2 Position kit (Manual Purge)
- 2 Position kit with timer (Manual and Auto Purge)
- Infinitely Variable Pitch Controller (IVP fan control)
- Each kit is available with or without an air compressor
- Available in 12V and 24V configurations

HYDRAULIC CONTROL:

- 2 Position kit (Manual Purge)
- 2 Position kit with timer (Manual and Auto Purge)
- Infinitely Variable Pitch Controller (IVP fan control)
- Available in 12V and 24V configurations

Contact Flexxaire or your dealer for details and availability.

2.1 MAJOR COMPONENTS

The Series 2000/Series 3000 Fan Assembly can be identified by several external components as shown in **Figure 1**. Use this diagram for terminology and major component identification. (This figure is of a Series 2000 Hydraulic, but all the major components are the same between the Series 2000 and Series 3000 fans.)

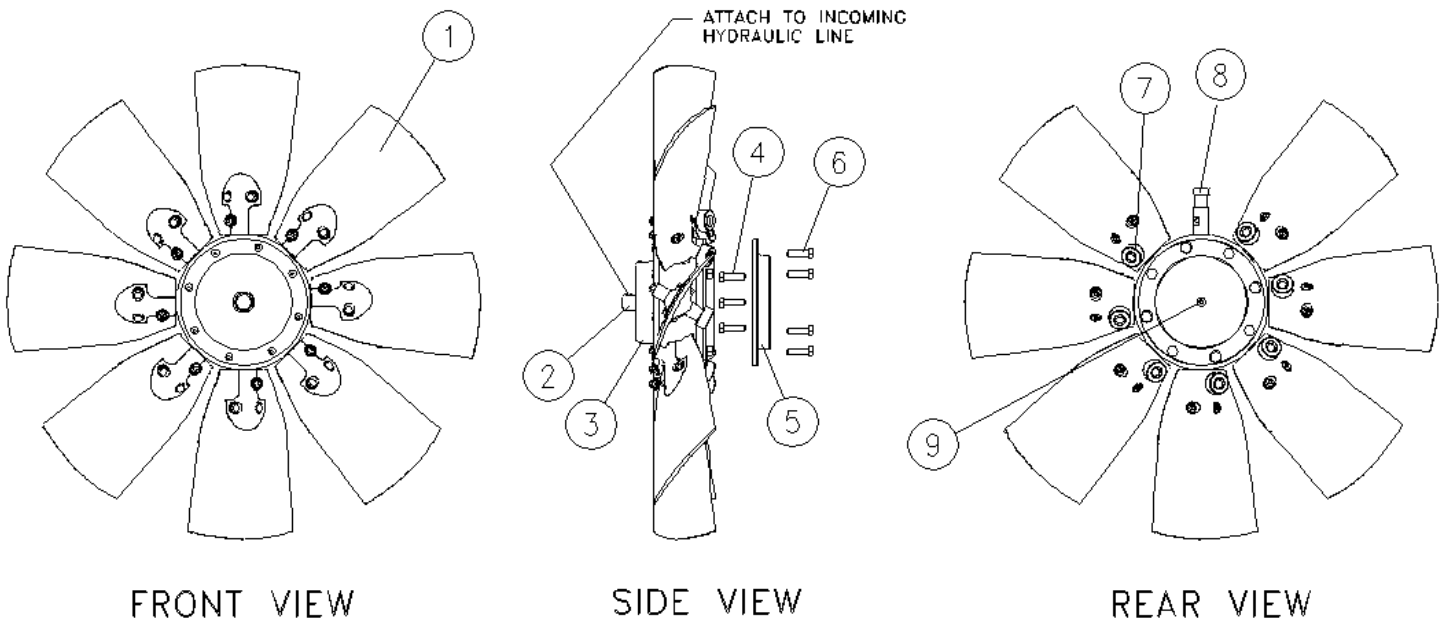

Figure 1

MAJOR COMPONENTS:

- | | | |
|-------------------|---------------------------|-------------------------|
| 1. Blade Assembly | 4. Mounting Adapter Bolts | 7. Blade Counter Weight |
| 2. Rotary Union | 5. Mounting Adapter | 8. Blade Mounting Shaft |
| 3. Hub Assembly | 6. Hub Mounting Bolts | 9. Fan Pilot |

2.2 EXISTING FAN REMOVAL

The following is a general description for the removal of an existing fan and the installation of a Flexxaire Series 2000/ Series 3000 Fan.

1. Remove fan guards and safety equipment to gain access to the existing fan.
2. Loosen belt(s) and remove existing fan hardware as required.
3. Clean mounting surface of the fan drive.

2.3 INSTALLATION

2.3.1 Mounting Adapters

The Series 2000/Series 3000 fan is supplied with a pre-machined mounting adapter plate. Pre-machined mounting adapters are machined for your pilot and bolt circle.

For some applications, a wider 2-piece adapter may be used, and the necessary hardware for assembling the 2 parts together will be included. This 2-piece adapter may be pre-assembled.

2.3.2 Fan Position

Ideally the fan should be centered in the shroud (30-70% immersion is acceptable). This may require modification or removal of the fan spacer or modification of the shroud. See **Figure 2**.

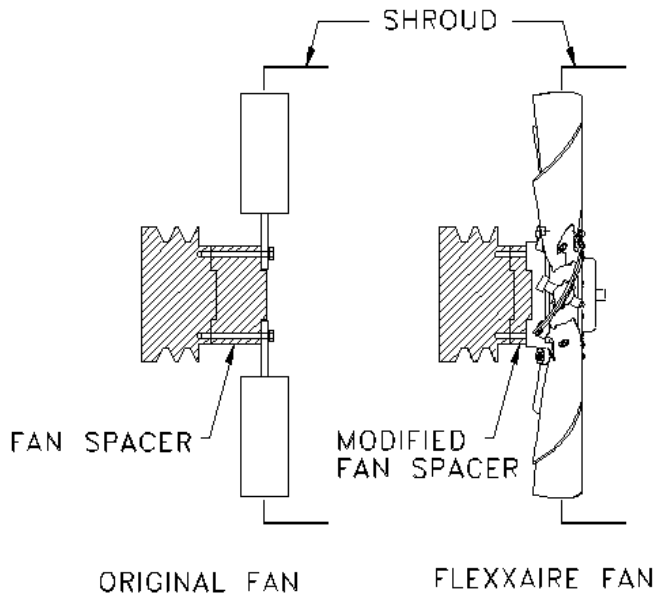

Figure 2

1. Install the Flexxaire supplied mounting adapter using bolts from the original fan. If the bolt length needs to be changed, use an equivalent or better grade of bolt. Follow original equipment manufacturer's torque and thread locking specifications when installing the mounting adapter to the fan drive. Refer to **Figure 3**.

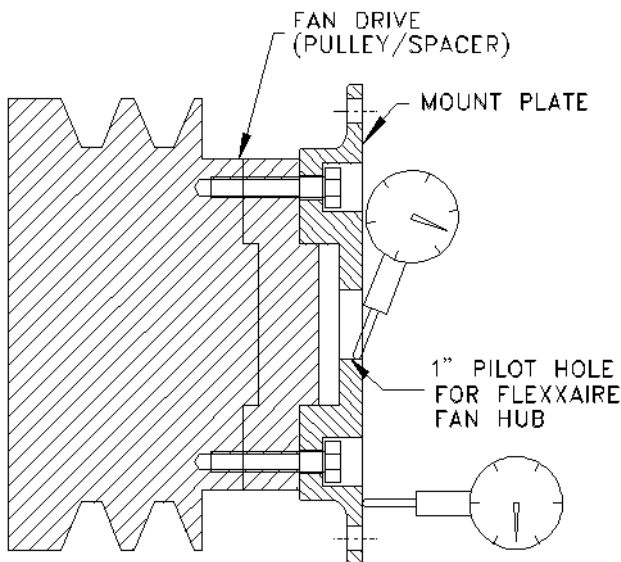

Figure 3

2. Set up dial gauge to measure axial deviation of the mounting adapter on the fan mounting surface. Deviation should not exceed 0.005". Refer to **Figure 3**.
3. Set up dial gauge to measure radial deviation of the mounting adapter on the 1" pilot hole surface. Deviation should not exceed 0.005". Refer to **Figure 3**.
4. Remove the shipping plug from the rear of the fan. Place the Series 2000/Series 3000 fan onto the mounting adapter and torque the 3/8" bolts to 30 Ft-Lbs (41 N.m). Do not use loctite. Refer to **Figure 4**.

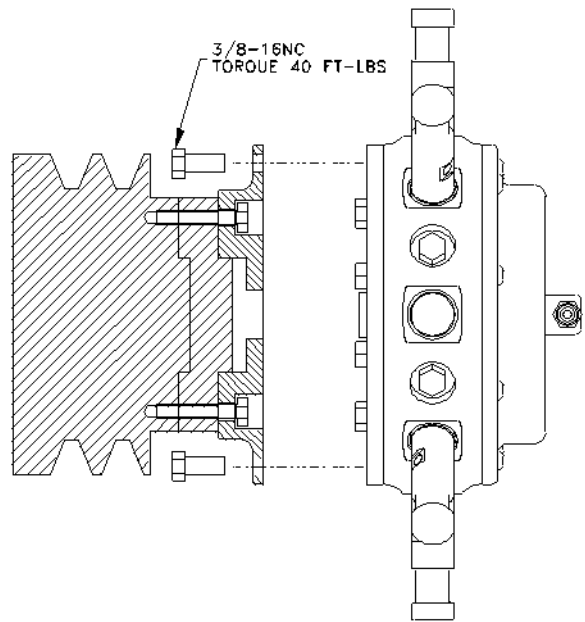

Figure 4

3.0 ATTACHING THE BLADES

Your Flexxaire fan shipped with the fan blades unattached. Care must be taken to ensure the blades are attached correctly.

If the primary operation of the fan is to "pull" air towards the engine, the blades must be mounted with the concave surface towards the engine (assuming the fan rotates counter clockwise, as viewed from the engine towards the fan).

If the primary operation of the fan is to "push" air away from the engine, the blades must be mounted with the concave surface away from the engine. Refer to **Figure 5**. (Some fans are shipped from Flexxaire with the blades already attached, by special order.)

Blades Mounted for Sucker Fan (Pull)

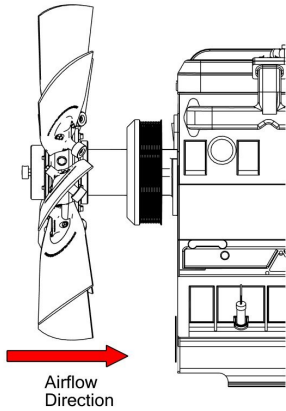

Blades Mounted for Blower Fan (Push)

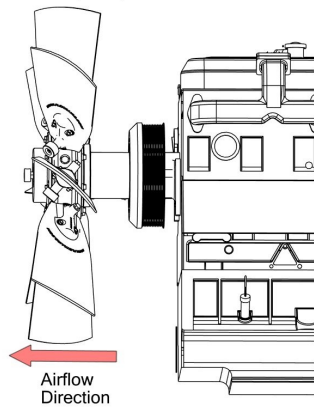

Figure 5

- Series 2000/Series 3000 fans are supplied with either 1 or 2 counterweights per blade. If two counter weights per blade are supplied, install one weight on each side.

If only one counterweight is supplied, then the counterweight can be installed on either side, as long as they are all on the same side.

Insert the supplied 1/4"NC long hex bolt through the counterweight then the lower hole in the blade or cap. The head of the bolt should be on the side with the counterweight when only one counter weight is being used. Tighten the assembly with the supplied 1/4"NC lock nut. See **Figure 6**.

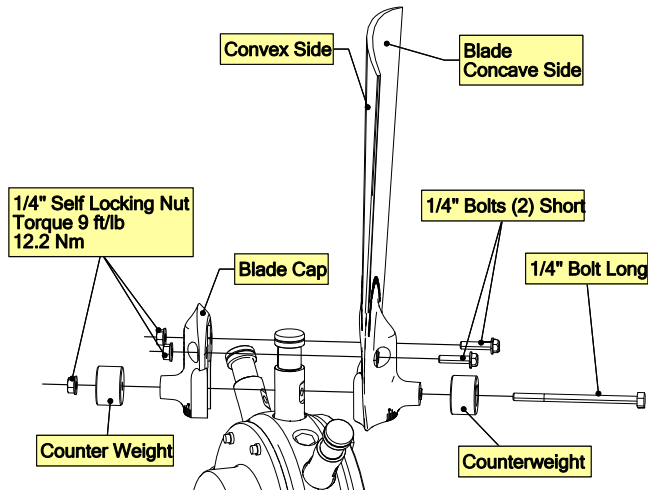

Figure 6

- Insert the 1/4" NC short bolts through the upper holes in the blade caps and blades. Tighten the assembly to the blade shaft and the blade. Regular hex head bolts with washers may be substituted for the flange headed bolts.
- Carefully torque the blade bolts with a certified torque wrench to the following specification:

1/4"–20NC to 9 ft./lbs

WARNING – DO NOT OVER TORQUE

NOTE: If any of the supplied flanged lock nuts are lost, they may be replaced with grade 8 flanged lock nuts. **Loctite 242 or equivalent must be applied to the bolt if lock nuts are not used.**

- Rotate the fan by hand and check for obstructions. A final check will be required once the pneumatic or hydraulic hose has been connected to the fan. (See Page 7 for a list of required pressures for each fan model.) Spin the fan by hand with the blade pitch reversed and check for obstructions.
- Ensure you have the correct blade clearance. See **Figure 7** on the next page or a list of recommended minimum clearances based on fan diameter.
- Tighten the fan belts and replace all the fan guards and safety equipment.
- Attach the "WARNING" label to the machine, on a housing, guard, or any location near the fan where it can be easily seen.

WARNING: Failure to have the correct blade clearance could result in blade contact that can cause extensive damage to people and equipment.

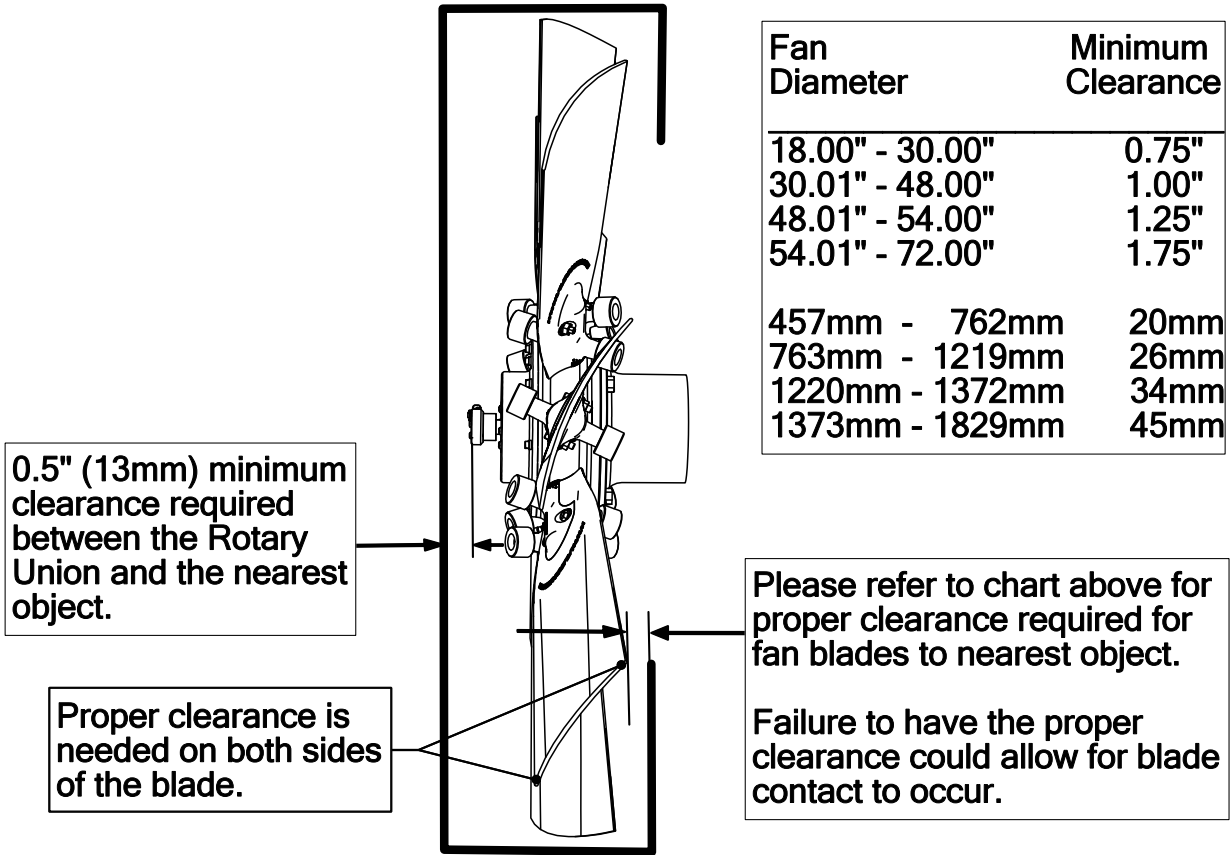

Figure 7

3.1 Series 3000 AIR DAM

Series 3000 fans above 54" in diameter have extended blade shafts, and an aluminum air dam/air seal is mounted to the front of the hub. This air dam is necessary to prevent reverse airflow between the bottom of the blades and the hub diameter.

The air dam is mounted with 5 bolts, on the front shoulder of the Series 3000 hub assembly.

See Figures 8 and 9.

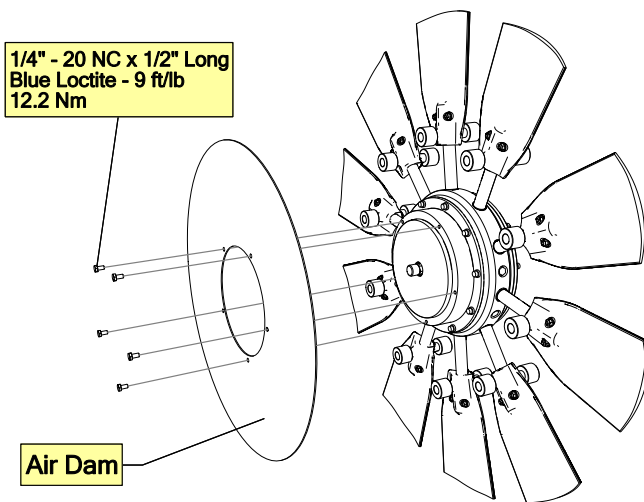

Figure 8

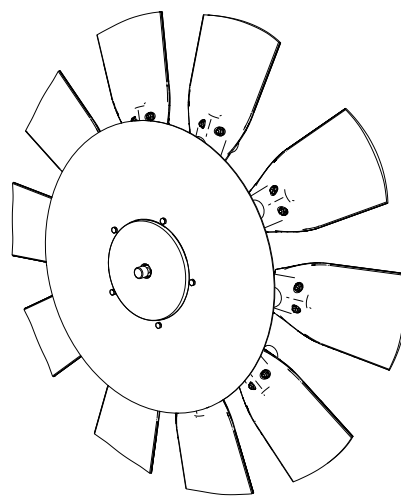

Figure 9

4.0 PNEUMATIC SPECIFICATIONS

Flexxaire supplies a number of pneumatic control options, but the Series 2000/ Series 3000 Pneumatic versions can be operated using any air source that meets the general specifications listed below. If your machine has air on board then this source will be available. If not, then a compressor kit will be required.

Series 2000 Pneumatic General Specifications:

Full Pitch (default position):	0 psi
Neutral Pitch (Stop air position):	75 psi
Reverse Pitch (Purge position):	98 psi
Max continuous pressure:	120 psi

(extended operation at higher pressure will reduce the life of the rotary union seal).

Series 3000 Pneumatic General Specifications:

Full Pitch (default position):	0 psi
Neutral Pitch (Stop air position):	45 psi
Reverse Pitch (Purge position):	57 psi
Max continuous pressure:	120psi

Recommended minimum flow rate: .35cfm @ 70 psi.
(The lower the flow rate, the longer it takes to purge the fan. –at .35cfm @ 70psi it takes approximately 7 seconds to fully reverse pitch).

4.1 PNEUMATIC LINE INSTALL

1. Drill a hole in your fan shroud to allow the flexible hose to be routed into the engine compartment. Secure the hose using hose clamps or tie wraps. Be sure that the air line is properly secured so it cannot interfere with the fan blades.
2. Attach the incoming air line to the push-in fitting on the front of the fan. If you did not purchase one of Flexxaire's control kits you will need to source flexible hose and fittings that will attach to the 1/8-NPT female fitting on the front of the fan. The hose should be robust enough to withstand abrasion from air flow, and temperature and vibration inherent from engines. Failure of the hose could lead to fan damage if the hose comes in contact with the blades.

WARNING: Do not secure the air lines in any way that will cause leverage to be applied to the rotary union. Failure of the rotary union could result.

5.0 HYDRAULIC SPECIFICATIONS

Flexxaire supplies a number of hydraulic control options, but the Series 2000/ Series 3000 Hydraulic versions can be operated using any hydraulic source that meets the general specifications listed below. If your machine has hydraulics on board then this source should be available.

Series 2000 Hydraulic General Specifications:

Full Pitch (default position):	0 psi
Neutral Pitch (Stop air position):	100 psi
Reverse Pitch (Purge position):	180psi
Maximum continuous pressure:	500 psi

Series 2000 High Pressure Hydraulic General Specifications:

Full Pitch (default position):	0 psi
Neutral Pitch (Stop air position):	310 psi
Reverse Pitch (Purge position):	460 psi
Maximum continuous pressure:	950 psi

Series 3000 Hydraulic General Specifications:

Full Pitch (default position):	0 psi
Neutral Pitch (Stop air position):	190 psi
Reverse Pitch (Purge position):	300 psi
Maximum continuous pressure:	500 psi

5.1 HYDRAULIC LINE INSTALL

1. Drill a hole in your fan shroud to allow the flexible hose to be routed into the engine compartment. Secure the hose using hose clamps.
2. No exterior bracing should be used to prevent the rotary union from rotating. It is imperative that a flexible connection be used. DO NOT PIPE SOLID.
3. Ensure that the hose clears all parts of the fan. If possible, secure the hose away from the fan. Common ways to do this are zip tie the hose to the radiator core, or to attach it to the radiator frame or the bolted flanges between the radiator cores.

WARNING: Do not secure the hydraulic hose so tight as to cause a side load on the rotary union. Failure of the bearings could result.

WARNING: Do not secure the hydraulic hose so loose that the hose could contact the blades due to sudden air reversal, vibration, etc....

WARNING: Ensure that you have the minimum clearance between the rotary union and closest obstruction as per Figure 7 on page 6.

- The fan is shipped with a default hose assembly attached to the hub assembly. Contact Flexxair if you want a different hose length of different fittings for future orders. The hose is attached at the Flexxair factory to avoid unnecessary side loads to the bearings of the rotary union that can be applied every time the hose is attached or detached from the rotary union.

5.2 HYDRAULIC LINE SPECIFICATIONS

Series 2000

- The connection on the rotary union is a 1/8NPT female thread.
- The fitting on the end of the default hose is a male 1/8NPT. An adapter is used to mate to the #6 ORB port on the manifold.
- If supplying your own hose, it is recommended to use a hose that is as small as possible. The potential exists that a large, heavy hose with bulky fittings could create a side load on the rotary union, just due to the weight of the hose. Side loads can drastically reduce the life of the rotary union.

4.

Series 3000

- The connection on the rotary union is a 1/8NPT female thread.
- The fitting on the end of the default hose is a flare 37 deg #4. An adapter is used to mate to the #6 ORB port on the manifold.
- If supplying your own hose, it is recommended to use a hose that is minimum 1/4" inside diameter. Smaller hoses can cause a problem with the fan performance as the small hose will slow down the actuation speed of the fan blades while changing pitch or purging.

6.0 SERVICE AND MAINTENANCE

Flexxair's Series 2000/Series 3000 fan hub is fully sealed with o-rings, and contains a small amount of oil. As a result, the fan should not require any maintenance.

6.1 VISUAL INSPECTIONS

Under normal operating conditions, Series 2000/ Series 3000 fans do not require any scheduled maintenance and are built to provide thousands of hours of trouble free service. In moderate to extreme operating conditions a visual inspection of the moving parts is recommended

from time to time to safeguard against fan blade damage which could lead to equipment downtime and/or other damages.

6.2 MECHANICAL REVIEW

- Ensure that the fan fully reverses pitch.
- Check for leaks in the rotary union.
- Check that the rotary union bearings rotate smoothly.
- Verify that you have the correct blade clearance as per **Figure 7** on page 6.

6.3 INSTALL CHECK LIST

CHECK	YES	NO
Does fan rotate in default and full reverse pitches without obstruction?	<input type="checkbox"/>	<input type="checkbox"/>
Are blade fasteners torqued to 9 ft-lbs	<input type="checkbox"/>	<input type="checkbox"/>
Are blades installed in the correct orientation (blower /sucker)? See Fig 5, page 5	<input type="checkbox"/>	<input type="checkbox"/>
Has the side load on the pressure line been minimized?	<input type="checkbox"/>	<input type="checkbox"/>
Has the pressure line been constrained to prevent contact with the blades?	<input type="checkbox"/>	<input type="checkbox"/>
Is the pressure line flexible enough to accommodate relative movement between the radiator and engine?	<input type="checkbox"/>	<input type="checkbox"/>
Are any of the blades damaged?	<input type="checkbox"/>	<input type="checkbox"/>
Does the rotary union rotate freely?	<input type="checkbox"/>	<input type="checkbox"/>
Are there any pressure leaks in the system?	<input type="checkbox"/>	<input type="checkbox"/>
Are all screens and guards secured?	<input type="checkbox"/>	<input type="checkbox"/>
Have you recorded the fan S/N for future reference? S/N _____	<input type="checkbox"/>	<input type="checkbox"/>

6.4 ROTARY UNION

The rotary union used in the fan hub is lubricated for life and requires no additional maintenance other than periodic inspection to determine if normal wear has caused the union to leak.

A locking ring is used to lock the rotary union into the fan system.

In addition, some fans are supplied with a Pitch Sensor or are Pitch Sensor Ready. These fans have a pin installed internally in the piston that travels through rotary union when installed. A jig is supplied with rotary union to verify pin center for applicable models. If your design does have the internal pin, please refer to Section 6.4.3 for proper use of jig.

6.4.1 ROTARY UNION REPLACEMENT

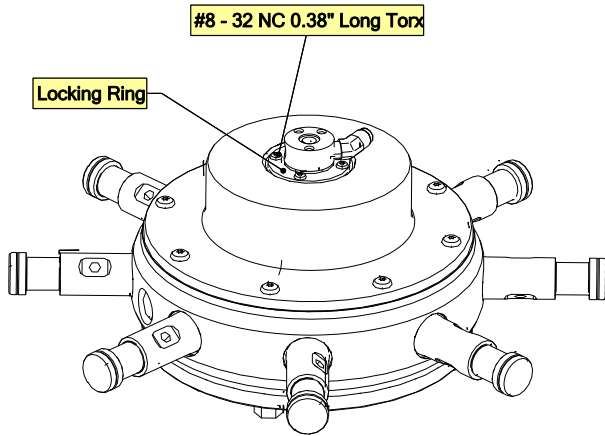

Figure 10

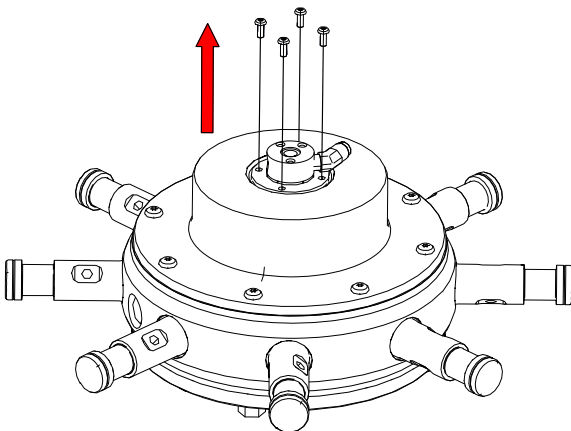

Figure 11

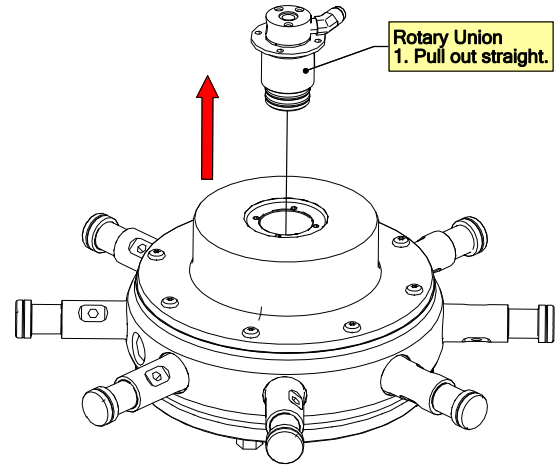

Figure 12

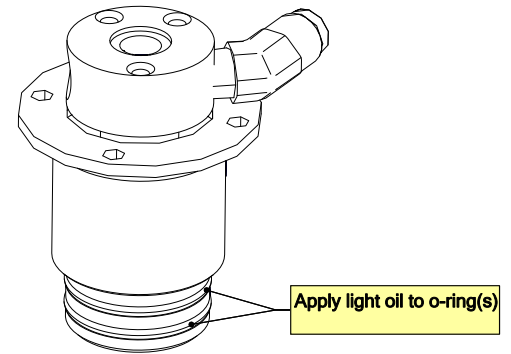

Figure 13

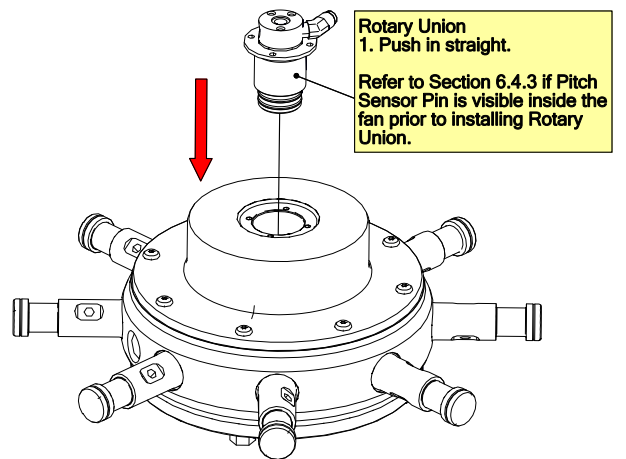

Figure 14

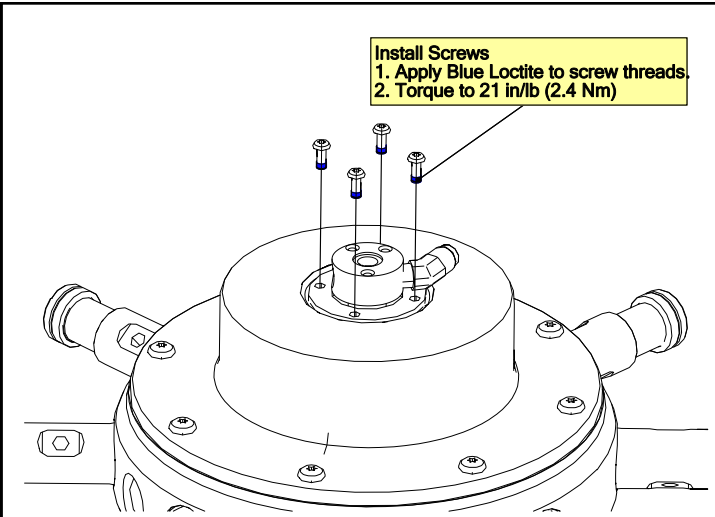

Figure 15

6.4.3 INTERNAL PIN VERIFICATION FOR PITCH SENSOR ENABLED/PITCH SENSOR READY FANS

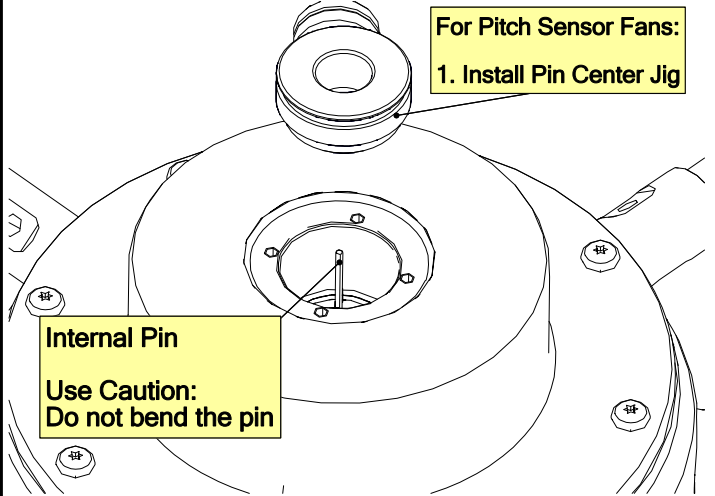

Figure 16

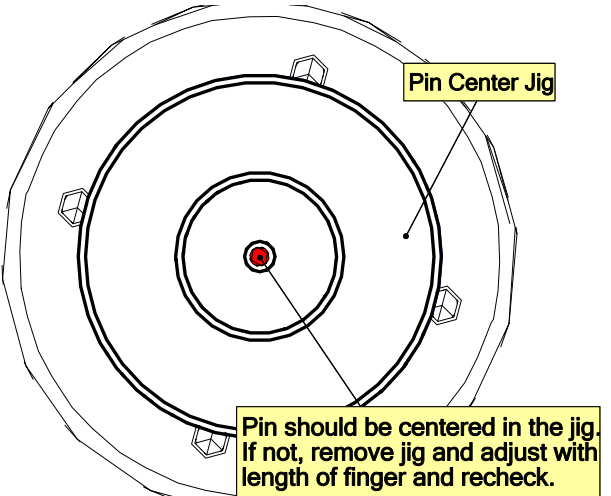

Figure 17