

SIEMENS



SITRANS

Pressure transmitter
SITRANS P DS III

Service Manual

Edition

06/2014

Answers for industry.

SIEMENS

SITRANS

Pressure transmitter SITRANS P DS III

Service Manual

<u>Introduction</u>	1
<u>Safety notes</u>	2
<u>Description</u>	3
<u>Connecting</u>	4
<u>Maintenance and servicing</u>	5
<u>Technical specifications</u>	6
<u>Ordering data for spare parts/accessories</u>	7
<u>Appendix</u>	A

7MF4.33.. 7MF4.34.. 7MF4.35..



06/2014

A5E34219855-01

Legal information

Warning notice system

This manual contains notices you have to observe in order to ensure your personal safety, as well as to prevent damage to property. The notices referring to your personal safety are highlighted in the manual by a safety alert symbol, notices referring only to property damage have no safety alert symbol. These notices shown below are graded according to the degree of danger.

 DANGER
indicates that death or severe personal injury will result if proper precautions are not taken.
 WARNING
indicates that death or severe personal injury may result if proper precautions are not taken.
 CAUTION
indicates that minor personal injury can result if proper precautions are not taken.
NOTICE
indicates that property damage can result if proper precautions are not taken.

If more than one degree of danger is present, the warning notice representing the highest degree of danger will be used. A notice warning of injury to persons with a safety alert symbol may also include a warning relating to property damage.

Qualified Personnel

The product/system described in this documentation may be operated only by **personnel qualified** for the specific task in accordance with the relevant documentation, in particular its warning notices and safety instructions. Qualified personnel are those who, based on their training and experience, are capable of identifying risks and avoiding potential hazards when working with these products/systems.

Proper use of Siemens products

Note the following:

 WARNING
Siemens products may only be used for the applications described in the catalog and in the relevant technical documentation. If products and components from other manufacturers are used, these must be recommended or approved by Siemens. Proper transport, storage, installation, assembly, commissioning, operation and maintenance are required to ensure that the products operate safely and without any problems. The permissible ambient conditions must be complied with. The information in the relevant documentation must be observed.

Trademarks

All names identified by ® are registered trademarks of Siemens AG. The remaining trademarks in this publication may be trademarks whose use by third parties for their own purposes could violate the rights of the owner.

Disclaimer of Liability

We have reviewed the contents of this publication to ensure consistency with the hardware and software described. Since variance cannot be precluded entirely, we cannot guarantee full consistency. However, the information in this publication is reviewed regularly and any necessary corrections are included in subsequent editions.

Table of contents

1	Introduction	7
1.1	Purpose of this documentation	7
1.2	Product information	7
1.3	History	7
1.4	Checking the consignment.....	8
1.5	Purpose.....	8
1.6	Checking the compatibility of the application electronics	9
1.7	Transportation and storage.....	11
1.8	Notes on warranty	12
2	Safety notes	15
2.1	Precondition for use	15
2.1.1	Laws and directives	15
2.1.2	Conformity with European directives	15
2.2	Improper device modifications	15
2.3	Use in hazardous areas	16
3	Description	19
3.1	Structure.....	19
3.2	Nameplate layout	20
3.3	Measuring point label layout	21
4	Connecting	23
4.1	Basic safety instructions	23
4.2	Connecting the device	26
5	Maintenance and servicing	29
5.1	Basic safety instructions	29
5.2	Defining the maintenance interval.....	32
5.3	Checking the gaskets.....	33
5.4	Display in case of a fault	34
5.5	Changing the measuring cell and application electronics.....	34
5.6	User data following replacement.....	35
5.7	Replacing parts	40
5.7.1	Guarantee information	40
5.7.2	Exploded view of the device	40
5.7.3	Replacing the connection board	41

5.7.4	Replacing the pushbutton module	43
5.7.5	Replacing the display	45
5.7.6	Replacing the application electronics	47
5.7.7	Replacing the measuring cell	49
5.8	Cleaning	51
5.8.1	Servicing the remote seal measuring system	52
5.9	Return procedure	53
5.10	Disposal.....	54
6	Technical specifications	55
7	Ordering data for spare parts/accessories	57
A	Appendix	65
A.1	Certificate	65
A.2	Technical support.....	65
A.3	Repair report for installation of spare parts	67
	Glossary	69
	Index	73

Introduction

1.1 Purpose of this documentation

These instructions contain all information that you will require to replace the application electronics, measuring cell, and connection board of the device.

For information about the safe usage of the device, refer to the detailed version of these instructions and corresponding safety instructions on the electronic data medium.

Read these instructions carefully before you start any service and maintenance work. In order to use the device correctly, first make yourself acquainted with its principle of operation.

Readership of these instructions are service and maintenance technicians.

1.2 Product information

The programming manual is an integral part of the CD, which is either supplied or can be ordered. The programming manual is also available on the Siemens homepage.

On the CD, you will also find the catalog extract with the ordering data, the Software Device Install for SIMATIC PDM for additional installation, and the required software.

See also

Product information on SITRANS P in the Internet (<http://www.siemens.com/sitransp>)

Catalog process instrumentation (<http://www.siemens.com/processinstrumentation/catalogs>)

1.3 History

This history establishes the correlation between the current documentation and the valid firmware of the device.

The documentation of this edition applies to the following firmware:

Edition	Firmware identifier nameplate	System integration	Installation path for PDM
06/2014	HART: FW: 11.03.03, FW: 11.03.04, FW: 11.03.05, FW: 11.03.06 PA: FW: 301.01.10 FF: FW: 11.01.01	SIMATIC PDM 8.x and previous versions	SITRANS P DSIII.2

1.4 Checking the consignment

1. Check the packaging and the spare parts for visible damage caused by inappropriate handling during shipping.
2. Report any claims for damages immediately to the shipping company.
3. Retain the damaged parts for clarification.
4. Check the scope of delivery by comparing your order with the shipping documents for correctness and completeness.

 **WARNING**

Using damaged or incomplete spare parts

Danger of explosion in hazardous areas.

- Do not use damaged or incomplete spare parts.

1.5 Purpose

Overview

Depending on the version, a transmitter measures corrosive, non-corrosive and hazardous gases, vapors and liquids.

You can use the transmitter for the following types of measurement:

- Gauge pressure
- Absolute pressure
- Differential pressure

With appropriate parameter settings and the necessary add-on parts (e.g. flow orifices and remote seals), the pressure transmitter can also be used for the following measurements:

- Level
- Volume
- Mass
- Volume of flow
- Mass flow rate

The output signal is always a load-independent direct current between 4 and 20 mA.

You can install the "intrinsically-safe" or "explosion-proof" version of the transmitter in hazardous areas. The devices have an EC type examination certificate and comply with the appropriate harmonized European CENELEC directives.

Transmitters with remote seals of different shapes can be delivered for special applications. For example, measuring high-viscosity substances is a special application.

Operate the device in accordance with the "Technical specifications" chapter in the operating instructions.

For additional information, refer to the operating instructions for the device.

1.6 Checking the compatibility of the application electronics

1. The table shown below indicates whether the new application electronics matches the device.
2. Check the product version on the application electronics sticker.
3. Check the compatibility mark on the nameplate of the device.

Table 1- 1 The following table is valid for: SITRANS P DS III with HART (7MF4.33..)

Product version (ES)	Compatibility mark	Remark
007 to 025	K = 01	Replacement not possible
030 to 035	K = 01	Replacement possible

Table 1- 2 The following table is valid for:
SITRANS P DS III with PA (7MF4.34..) and SITRANS P DS III with FF (7MF4.35..)

Product version (ES)	Compatibility mark	Remark
001 to 015	K = 01	Replacement possible

1.6 Checking the compatibility of the application electronics



Example of application electronics for SITRANS P DS III with PA and FF



Example of application electronics for SITRANS P DS III with HART

① Product version (ES)

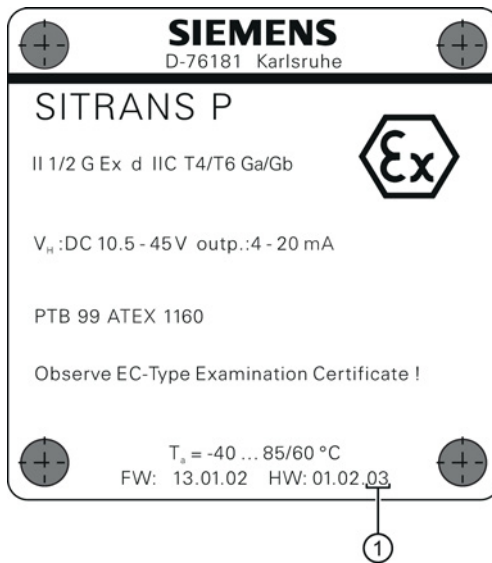

① Compatibility mark

Figure 1-1 Compatibility mark on the nameplate

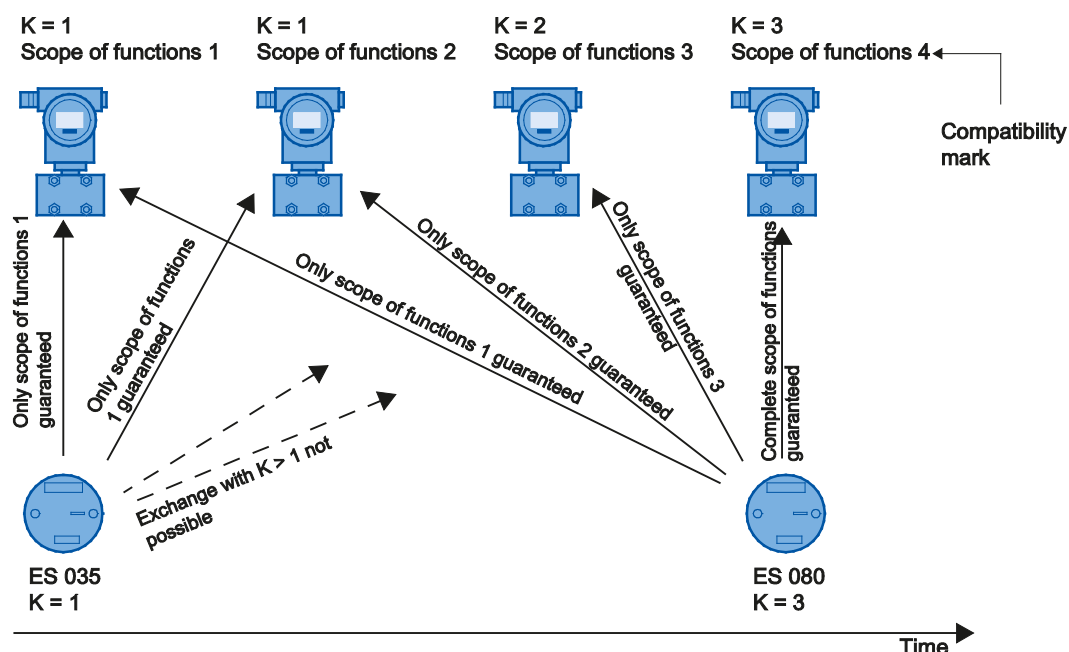

Figure 1-2 Example of incrementing of product version and compatibility mark and their possible combinations for future developments

See also

Nameplate layout (Page 20)

1.7 Transportation and storage

To guarantee sufficient protection during transport and storage, observe the following:

- Keep the original packaging for subsequent transportation.
- Devices/replacement parts should be returned in their original packaging.
- If the original packaging is no longer available, please ensure that all shipments are sufficiently protected during transport by the replacement packaging. Siemens accepts no liability for additional costs resulting from damage in transit.

 CAUTION
Insufficient protection during storage
The packaging only provides limited protection against moisture and infiltration.
<ul style="list-style-type: none"> • Provide additional packaging as necessary.

Information on special conditions for storage and transportation of the device and spare parts can be found in the "Technical specifications" chapter in the operating instructions.

1.8 Notes on warranty

The contents of this manual shall not become part of or modify any prior or existing agreement, commitment or legal relationship. The sales contract contains all obligations on the part of Siemens as well as the complete and solely applicable warranty conditions. Any statements regarding device versions described in the manual do not create new warranties or modify the existing warranty.

The content reflects the technical status at the time of publishing. Siemens reserves the right to make technical changes in the course of further development.

Safety notes

2.1 Precondition for use

2.1.1 Laws and directives

Observe the test certification, provisions and laws applicable in your country during connection, assembly and operation. These include, for example:

- National Electrical Code (NEC - NFPA 70) (USA)
- Canadian Electrical Code (CEC) (Canada)

Further provisions for hazardous area applications are for example:

- IEC 60079-14 (international)
- EN 60079-14 (EC)

2.1.2 Conformity with European directives

The device complies with the European directives even following the use of replacement parts.

2.2 Improper device modifications

 WARNING
Improper device modifications Danger to personnel, system and environment can result from modifications to the device, particularly in hazardous areas. <ul style="list-style-type: none">• Only carry out modifications that are described in the instructions for the device. Failure to observe this requirement cancels the manufacturer's warranty and the product approvals.

2.3 Use in hazardous areas

Qualified personnel for hazardous area applications

Persons who install, connect, commission, operate, and service the device in a hazardous area must have the following specific qualifications:

- They are authorized, trained or instructed in operating and maintaining devices and systems according to the safety regulations for electrical circuits, high pressures, aggressive, and hazardous media.
- They are authorized, trained, or instructed in carrying out work on electrical circuits for hazardous systems.
- They are trained or instructed in maintenance and use of appropriate safety equipment according to the pertinent safety regulations.

WARNING

Loss of the safety of the device with type of protection "Intrinsic safety Ex i"

If the device has already been operated in non-intrinsically safe circuits or the information on the electrical specifications have been ignored, the safety of the device is no longer ensured for use in hazardous areas. There is a danger of explosion.

- Connect the device in Intrinsic Safety type of protection solely to an intrinsically safe circuit.
- Observe the information on the electrical specifications in the certificate and in the "Technical specifications" chapter in the operating instructions.

WARNING

Use of incorrect device parts in potentially explosive environments

Devices and their associated device parts are either approved for different types of protection or they do not have explosion protection. There is a danger of explosion if device parts (such as covers) are used for devices with explosion protection that are not expressly suited for this type of protection. If you do not adhere to these guidelines, the test certificates and the manufacturer warranty will become null and void.

- Use only device parts that have been approved for the respective type of protection in the potentially explosive environment. Covers that are not suited for the "explosion-proof" type of protection are identified as such by a notice label attached to the inside of the cover with "Not Ex d Not SIL".
- Do not swap device parts unless the manufacturer specifically ensures compatibility of these parts.

 **WARNING**

Risk of explosion due to electrostatic charge

To prevent the build-up of an electrostatic charge in a hazardous area, the key cover must be closed during operation and the screws tightened.

The key cover may be opened temporarily at any time for the purposes of operating the pressure transmitter, even during plant operation; the screws should then be tightened again.

Description

3.1 Structure

Depending on a customer-specific order, the device comprises different parts.

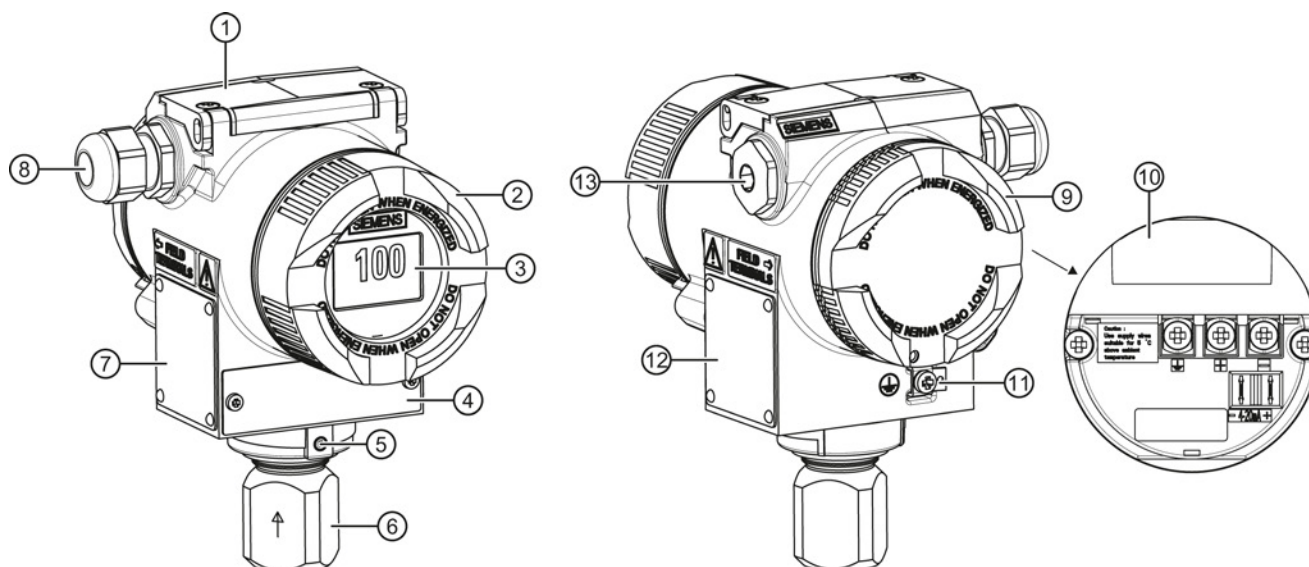

- | | | | |
|---|--|---|---|
| ① | Key cover | ⑧ | Cable inlet, optionally with cable gland |
| ② | Cover (front), optionally with inspection window | ⑨ | Cover (rear) for electrical terminal compartment |
| ③ | Display (optional) | ⑩ | Electrical terminal compartment |
| ④ | Measuring point label | ⑪ | Protective conductor connector/equipotential bonding terminal |
| ⑤ | Retaining screw; twist proofing of the measuring cell in relation to the electronics enclosure | ⑫ | Nameplate (approval information) |
| ⑥ | Process connection | ⑬ | Blanking plug |
| ⑦ | Nameplate (general information) | | |

Figure 3-1 View of the transmitter: Left: Front right: Rear view

- The electronics enclosure is made of die cast aluminum or precision cast stainless steel.
- The housing has a removable circular cover at the front and the back.
- Depending on the device version, the front cover ② may be designed as an inspection window. You can read the measured values straight off the digital display through this inspection window.
- The cable inlet ⑧ to the electrical terminal compartment is at the side; either the left or right-hand one can be used. The unused opening is closed with a blanking plug ⑬.
- The protective conductor terminal/equipotential bonding terminal ⑪ is located at the back of the enclosure.

3.2 Nameplate layout

- The electrical terminal compartment ⑩ for the auxiliary power and shield is accessible when you remove the back cover ⑨.
- The measuring cell with a process connection ⑥ is located in the lower section of the enclosure. This measuring cell is secured against twisting by a retaining screw ⑤. Thanks to the modular design of the transmitter, the measuring cell and application electronics or connection board can be replaced if required.
- On the upper face of the enclosure you can see crosshead screws which secure the key cover ①, under which there are 3 keys for local operation.

3.2 Nameplate layout

Nameplate with general information

The nameplate bearing the Order No. and other important information, such as design details and technical data, is on the side of the enclosure.

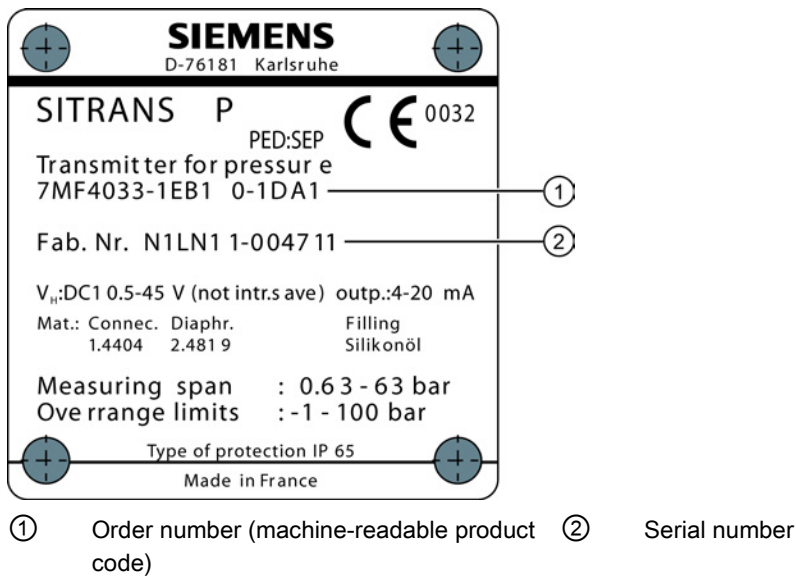

Figure 3-2 Example of a nameplate

Nameplate with approval information

On the opposite side is the nameplate with approval information. This nameplate shows e.g. the hardware and firmware versions. You must also observe the information in the relevant certificate for a transmitter version for use in hazardous areas.

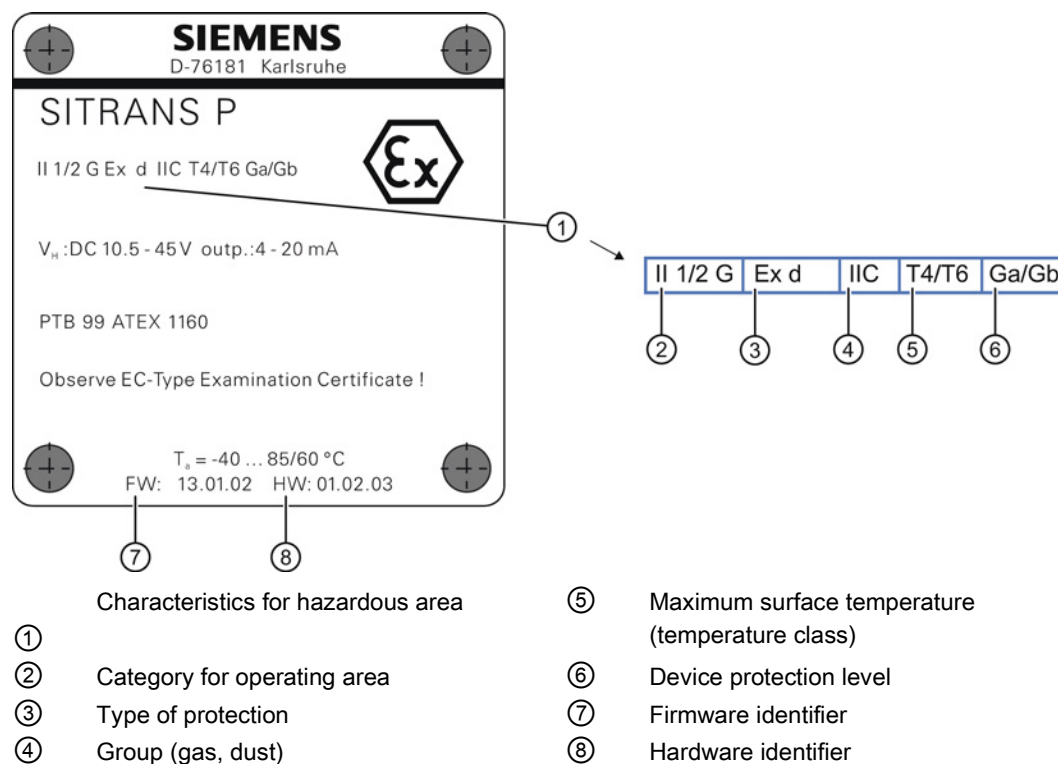

Figure 3-3 Example of a nameplate

3.3 Measuring point label layout

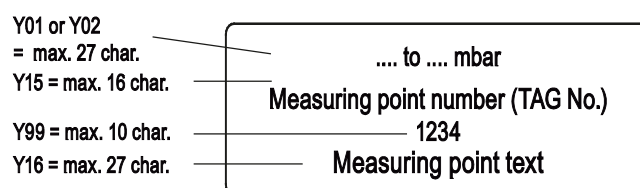



Figure 3-4 Example of measuring point label

Description

3.3 Measuring point label layout

4.1 Basic safety instructions

 WARNING
Unsuitable cables and/or cable glands Danger of explosion in hazardous areas. <ul style="list-style-type: none">• Only use appropriate cables and cable glands complying with the requirements specified in the "Technical specifications" chapter in the operating instructions.• Tighten the cable glands in accordance with the torques specified in the "Technical specifications" chapter in the operating instructions.• When replacing cable glands, only use ones of the same type.• After installation check that the cables are seated firmly.

 WARNING
Hazardous contact voltage in versions with 4-conductor extension Danger of electrocution in case of incorrect connection. <ul style="list-style-type: none">• Observe the instructions in the 4-conductor extension operating manual for the electrical connection.

 WARNING
Improper power supply Danger of explosion in hazardous areas as result of incorrect power supply, e.g. using direct current instead of alternating current. <ul style="list-style-type: none">• Connect the device in accordance with the specified power supply and signal circuits. The relevant specifications can be found in the certificates, in the "Technical specifications" chapter in the operating instructions, or on the nameplate.

 WARNING
Unsafe extra-low voltage Danger of explosion in hazardous areas due to voltage flashover. <ul style="list-style-type: none">• Connect the device to an extra-low voltage with safe isolation (SELV).

 WARNING
Lack of equipotential bonding Danger of explosion through compensating currents or ignition currents through lack of equipotential bonding. <ul style="list-style-type: none">• Ensure that the device is potentially equalized. Exception: It may be permissible to omit connection of the equipotential bonding for devices with type of protection "Intrinsic safety Ex i".

 WARNING
Unprotected cable ends Danger of explosion through unprotected cable ends in hazardous areas. <ul style="list-style-type: none">• Protect unused cable ends in accordance with IEC/EN 60079-14.

 WARNING
Improper laying of shielded cables Danger of explosion through compensating currents between hazardous area and the non-hazardous area. <ul style="list-style-type: none">• Only ground shielded cables that run into the hazardous area at one end.• If grounding is required at both ends, use an equipotential bonding conductor.

 WARNING
Connecting device in energized state Danger of explosion in hazardous areas. <ul style="list-style-type: none">• Connect devices in hazardous areas only in a de-energized state. Exceptions: <ul style="list-style-type: none">• Circuits of limited energy may also be connected in the energized state in hazardous areas.• Exceptions for type of protection "Non-sparking nA" (Zone 2) are regulated in the relevant certificate

 WARNING**Incorrect selection of type of protection**

Danger of explosion in areas subject to explosion hazard.

This device is approved for several types of protection.

1. Decide in favor of one type of protection.
2. Connect the device in accordance with the selected type of protection.
3. In order to avoid incorrect use at a later point, make the types of protection that are not used permanently unrecognizable on the nameplate.

NOTICE**Ambient temperature too high**

Damage to cable sheath.

- At an ambient temperature ≥ 60 °C (140 °F), use heat-resistant cables suitable for an ambient temperature at least 20 °C (68 °F) higher.

NOTICE**Incorrect measured values with incorrect grounding**

The device must not be grounded via the "+" connection. It may otherwise malfunction and be permanently damaged.

- If necessary, ground the device using the "-" connection.

Note**Electromagnetic compatibility (EMC)**

You can use this device in industrial environments, households and small businesses.

For metal housings there is an increased electromagnetic compatibility compared to high-frequency radiation. This protection can be increased by grounding the housing, see Chapter "Connecting the device (Page 26)".

Note

Improvement of interference immunity

- Lay signal cables separate from cables with voltages > 60 V.
 - Use cables with twisted wires.
 - Keep the device and the cables at a distance from strong electromagnetic fields.
 - Use shielded cables to guarantee the full specification according to HART.
 - Refer to the information on HART communication in the "Technical specifications" chapter in the operating instructions.
-

4.2 Connecting the device

Opening the device

1. Unscrew the cover of the electrical cable compartment. An identification text "FIELD TERMINALS" is provided at the side of the housing.

Connecting the device

1. Lead the connecting cable through the cable gland ③.
2. Connect the device to the plant with the protective conductor connection ⑦.
3. Connect the wires to the connecting terminals ④ "+" and "-".
Ensure the correct polarity! If necessary, ground the device using the "-" connection by connecting the "-" connection to the ground terminal ⑨.
4. If necessary, connect the shield to the screw of the ground terminal ⑨. This is electrically connected with the external protective conductor connection.

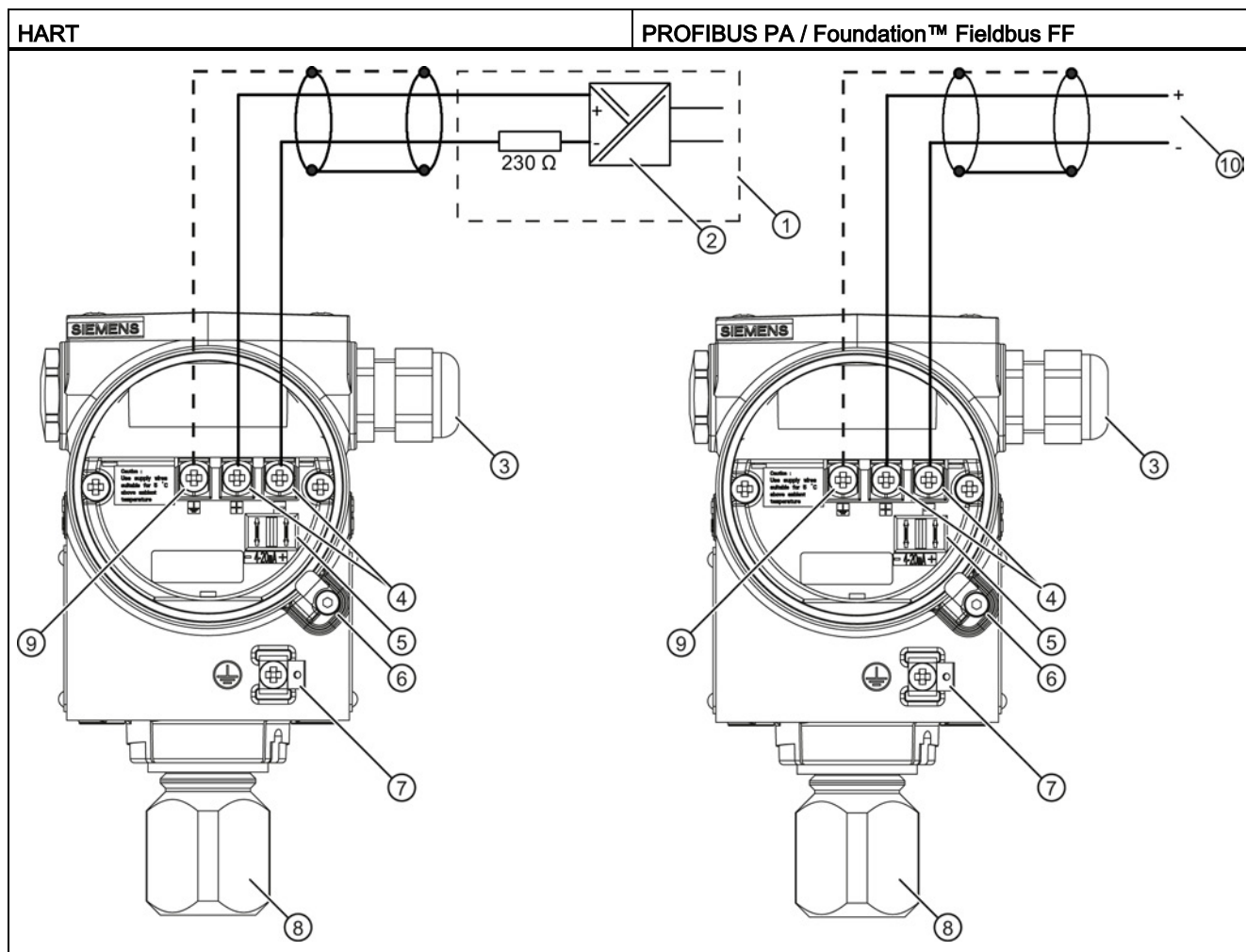

- | | |
|---|--|
| ① Feed separator with integrated load | ⑥ Safety catch |
| ② Auxiliary power | ⑦ Protective conductor connection/
equipotential bonding terminal |
| ③ Cable entry for auxiliary power/analog
output | ⑧ Process connection |
| ④ Connecting terminals | ⑨ Ground terminal |
| ⑤ Test connector for direct current
measuring device or connection for
external display | ⑩ PROFIBUS PA / Foundation™ Fieldbus
FF |

Electrical connection, power supply

Closing the device

1. Screw the covers ④ ⑦ back on as far as they will go.
2. Secure each cover with the cover catch ③ ⑥.
3. Close the key cover ①.
4. Tighten the screws in the key cover.
5. Check the tightness of the blanking plugs ⑤ and cable gland ② in accordance with the degree of protection.

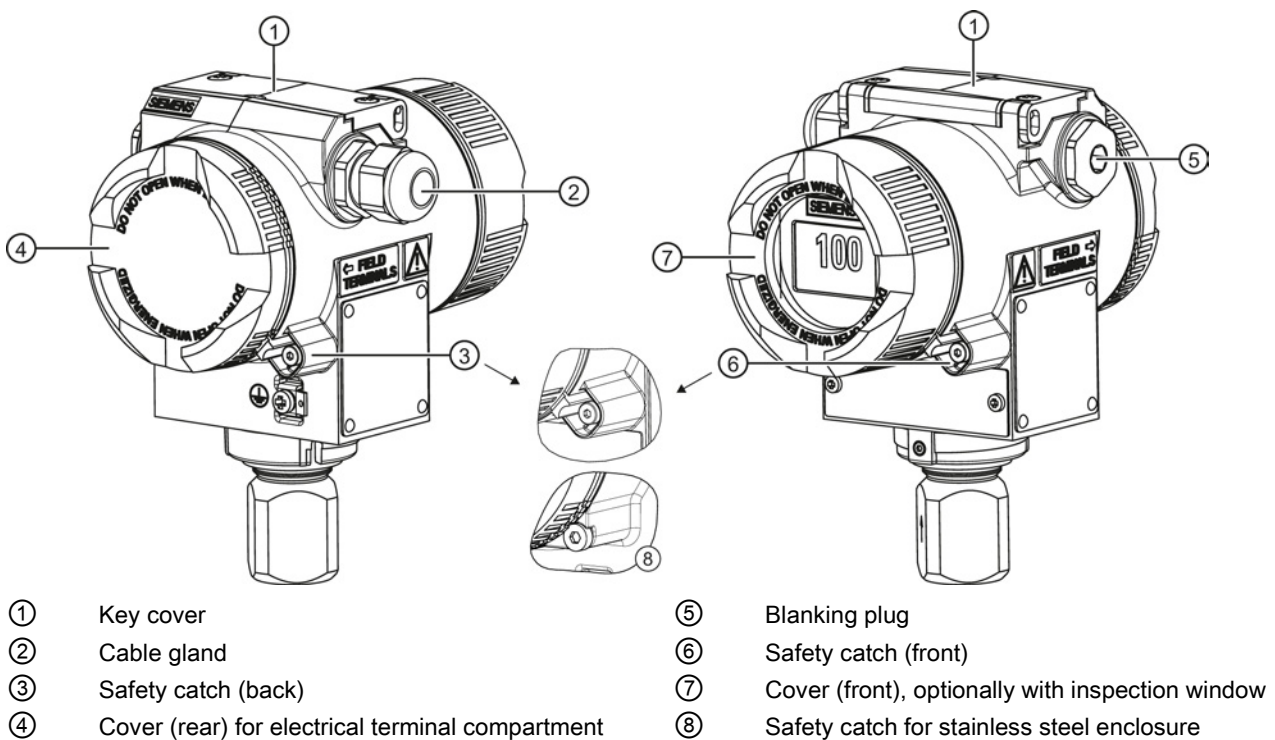



Figure 4-1 View of the transmitter: Left: Back right: Front view

Maintenance and servicing

5.1 Basic safety instructions

 WARNING
Impermissible repair of explosion protected devices
Danger of explosion in areas subject to explosion hazard.
<ul style="list-style-type: none">• Repair must be carried out by Siemens authorized personnel only.

 WARNING
Impermissible accessories and spare parts
Danger of explosion in areas subject to explosion hazard.
<ul style="list-style-type: none">• Only use original accessories or original spare parts.• Observe all relevant installation and safety instructions described in the instructions for the device or enclosed with the accessory or spare part.

 WARNING
Use of incorrect device parts in potentially explosive environments
Devices and their associated device parts are either approved for different types of protection or they do not have explosion protection. There is a danger of explosion if device parts (such as covers) are used for devices with explosion protection that are not expressly suited for this type of protection. If you do not adhere to these guidelines, the test certificates and the manufacturer warranty will become null and void.
<ul style="list-style-type: none">• Use only device parts that have been approved for the respective type of protection in the potentially explosive environment. Covers that are not suited for the "explosion-proof" type of protection are identified as such by a notice label attached to the inside of the cover with "Not Ex d Not SIL".• Do not swap device parts unless the manufacturer specifically ensures compatibility of these parts.

 **WARNING**

Maintenance during continued operation in a hazardous area

There is a danger of explosion when carrying out repairs and maintenance on the device in a hazardous area.

- Isolate the device from power.

- or -

- Ensure that the atmosphere is explosion-free (hot work permit).

 **WARNING**

Commissioning and operation with pending error

If an error message appears, correct operation in the process is no longer guaranteed.

- Check the gravity of the error.
- Correct the error.
- If the error still exists:
 - Take the device out of operation.
 - Prevent renewed commissioning.

 **WARNING**

Hot, toxic or corrosive process media

Danger of injury during maintenance work.

When working on the process connection, hot, toxic or corrosive process media could be released.

- As long as the device is under pressure, do not loosen process connections and do not remove any parts that are pressurized.
- Before opening or removing the device ensure that process media cannot be released.

 **WARNING**

Improper connection after maintenance

Danger of explosion in areas subject to explosion hazard.

- Connect the device correctly after maintenance.
- Close the device after maintenance work.

Refer to Chapter "Connecting the device (Page 26)".

 **WARNING**

Use of a computer in a hazardous area

If the interface to the computer is used in the hazardous area, there is a danger of explosion.

- Ensure that the atmosphere is explosion-free (hot work permit).

 **CAUTION**

Releasing key lock

Improper modification of parameters could influence process safety.

- Make sure that only authorized personnel may cancel the key locking of devices for safety-related applications.

 **CAUTION**

Hot surfaces

Danger of burns during maintenance work on parts having surface temperatures exceeding 70 °C (158 °F).

- Take corresponding protective measures, for example by wearing protective gloves.
- After carrying out maintenance, remount touch protection measures.

 **WARNING**

Hazardous voltage with open device in versions with 4-conductor extension

Danger of electrocution when the enclosure is opened or enclosure parts are removed.

- Disconnect the device before you open the enclosure or remove enclosure parts.
- Observe the special precautionary measures if maintenance is required while the device is live. Have maintenance work carried out by qualified personnel.

NOTICE
Electrostatic-sensitive devices The device contains electrostatic-sensitive devices (ESD). ESD can be destroyed by voltages far too low to be detected by humans. These voltages can occur if you simply touch a component part or the electrical connections of a module without being electrostatically discharged. The damage to a module caused by overvoltage cannot normally be detected immediately; it only becomes apparent after a longer period of operating time has elapsed. Protective measures against the discharge of static electricity: <ul style="list-style-type: none">• Make sure that no power is applied.• Before working with modules, make sure that you discharge static from your body, for example by touching a grounded object.• Devices and tools used must be free of static charge.• Hold modules only by their edges.• Do not touch connector pins or conductor tracks on a module with the ESD notice.

5.2 Defining the maintenance interval

 WARNING
No maintenance interval has been defined Device failure, device damage, and risk of injury. <ul style="list-style-type: none">• Define a maintenance interval for regular tests in line with device use and empirical values.• The maintenance interval will vary from site to site depending on corrosion resistance.

5.3 Checking the gaskets

Inspect the seals at regular intervals

Note**Incorrect seal changes**

Incorrect measured values will be displayed. Changing the seals in a process flange of a differential pressure measuring cell can alter the start-of-scale value.

- Changing seals in devices with differential pressure measuring cells may only be carried out by personnel authorized by Siemens.
-

Note**Using the wrong seals**

Using the wrong seals with flush-mounted process connections can cause measuring errors and/or damage the diaphragm.

- Always use seals which comply with the process connection standards or are recommended by Siemens.
-

1. Clean the enclosure and seals.
2. Check the enclosure and seals for cracks and damage.
3. Grease the seals if necessary.
- or -
4. Replace the seals.

5.4 Display in case of a fault

Check the start of scale value of the device from time to time.

Differentiate between the following in case of a fault:

- The internal self test has detected a fault, e.g. sensor break, hardware fault/Firmware fault.

Displays:

- Display: "ERROR" display and ticker with an error text
- Analog output: Factory setting: Failure current 3.6 or 22.8 mA

Or depending on the parameterization

- HART: detailed error breakdown for display in the HART communicator or SIMATIC PDM

- Grave hardware faults, the processor is not functioning.

Displays:

- Display: no defined display
- Analog output: failure current < 3.6 mA

In the event of a defect, you can replace the application electronics by following the warning notes and the provided operating instructions.

5.5 Changing the measuring cell and application electronics

Related

Each of the individual components "Measuring cell" and "Electronics" has a non-volatile memory (EEPROM).

Measuring cell data (e.g.: measuring range, measuring cell material, oil filling) and user data of the application electronics (e.g.: downscaling, additional electrical damping) are located in the measuring cell EEPROM. User data is lost when the measuring cell is replaced. Application-specific data are not lost when the application electronics are changed.

You can backup user data before changing the measuring cell and reload it afterwards. Use an input device which supports the HART protocol. (e.g. HART communicator, PC with HART modem and HART software or PC with HART modem and PDM software). Factory settings will be used if user data is not backed up before the measuring cell is changed.

Technical developments enable advanced functions to be implemented in the firmware of the measuring cell or application electronics. Further technical developments are indicated by modified firmware statuses (FW). The firmware status does not affect whether the modules can be replaced. However, the scope of functions is limited to the function of existing components.

If a combination of certain firmware versions of measuring cell and application electronics is not possible for technical reasons, the device will identify this problem and go into "Fault current" mode. This information is provided via the HART interface.

5.6 User data following replacement

This chapter describes which user data is reset to the factory setting following replacement of the application electronics or measuring cell.

The following tables are identified as follows:

*: The parameter names identified by * can be found in SIMATIC PDM under the menu items "Device" or "View".

①: The user data identified by ① is reset to the factory setting following replacement of the measuring cell.

②: The user data identified by ② is reset to the factory setting following replacement of the application electronics.

Table 5- 1 SITRANS P DS III with HART

Parameter name in SIMATIC PDM	Status of user data following replacement of application electronics or measuring cell	Value following resetting to factory setting
Operating unit / TAG	①	-
Device / sensor serial number	①	-
Unit and cycle time / unit	①	bar
Unit and cycle time / cycle time	①	90 ms
Measuring limits / min. measuring range	①	-
Measuring limits / min. start-of-scale value, max. full-scale value	①	-
Measured-value scaling, start-of-scale value	①	0.0
Measured-value scaling, full-scale value	①	Upper sensor limit
Analog output limits / lower/upper limit	①	3.8 / 20.5 mA
Alarm status / analog output alarm type	①	Lower
Alarm status / lower/upper alarm value	①	3.6 / 22.8 mA
Damping	①	0.1 s
Characteristic / transfer function	①	Linear
Characteristic / start of root extraction	①	5 %
Display and user interface / tracking unit	①	mA
Design (all material data)	①	-
Sensor calibration / upper/lower calibration point	①	Like factory-set sensor limits, without transformation
Sensor calibration / lower calibration point	①	0.0
Sensor calibration / upper calibration point	①	Upper sensor limit
Service interval for sensor (all settings)	①	-

5.6 User data following replacement

Parameter name in SIMATIC PDM	Status of user data following replacement of application electronics or measuring cell	Value following resetting to factory setting
Certificates and approvals / explosion protection	①	-
* Polling address	①	-
* Min/max pointers for pressure / sensor temperature	①	-
* Sensor calibration / zero calibration	①	-
* Sensor calibration / upper/lower calibration	①	-
* Position error calibration	①	0.0
* Operating hours counter, sensor	①	-
Operating unit / message	②	-
Operating unit / description	②	-
Device / software revision	②	-
Device / hardware revision	②	-
Device / field device revision	②	-
Device / date	②	-
Device / factory number	②	-
Display and user interface / local display unit	②	-
Display and user interface / bargraph	②	-
Display and user interface / local operation	②	-
Calibration interval for application electronics (all settings)	②	-
Current saturation monitoring / alarm activation	②	-
Current saturation monitoring / saturation alarm, alarm duration	②	-
* Operating hours counter, application electronics	②	-
* Analog output D/A calibration (customer-specific)	②	Like factory-set D/A calibration
* Min/max pointers for application electronics temperature	②	-

Table 5- 2 SITRANS P DS III with PA

Parameter name in SIMATIC PDM	Status of user data following replacement of application electronics or measuring cell
Identification / device / sensor type	①
Identification / device / sensor serial number	①

Parameter name in SIMATIC PDM	Status of user data following replacement of application electronics or measuring cell
Input / transducer block 1 / measuring limits / min. start-of-scale value	①
Input / transducer block 1 / measuring limits / max. full-scale value	①
Conditions of use / process conditions / max. media pressure limit	①
Diagnostics settings / service interval for sensor (all settings)	①
Design / type / measuring cell / measuring cell filling	①
Design / type / measuring cell / seal diaphragm material	①
Design / type / measuring cell / O-ring material	①
Design / type / remote seal / number of remote seal flanges	①
Design / type / remote seal / remote seal type	①
Design / type / remote seal / diaphragm material	①
Design / type / remote seal / remote seal filling	①
Design / type / remote seal / tube length	①
Design / type / process connection / process connection type	①
Design / type / process connection / venting valve material	①
Design / type / process connection / venting valve position	①
Design / type / process connection / process flange screws	①
Design / type / process connection / flange type	①
Design / type / process connection / flange material	①
Design / electrical connection / electronics housing material	①
Design / electrical connection / electrical connection	①
Certificates and approvals / explosion protection	①
* Operating hours counter, sensor	①
* Min/max pointers for pressure / sensor temperature	①
Identification / operating unit / TAG	②
Identification / operating unit / description	②

5.6 User data following replacement

Parameter name in SIMATIC PDM	Status of user data following replacement of application electronics or measuring cell
Identification / operating unit / message	②
Identification / device / device serial number	②
Identification / device / software revision	②
Identification / device / hardware revision	②
Identification / device / PROFIBUS Ident Number	②
Identification / device / installation date	②
Identification / device / Order No.	②
Input / transducer block 1 / transducer type	②
Input / transducer block 1 / measuring limits / pressure unit, raw value	②
Input / transducer block 1 / measuring range / unit (secondary variable 1)	②
Input / transducer block 1 / measuring range / start-of-scale value	②
Input / transducer block 1 / measuring range / full-scale value	②
Input / transducer block 1 / working range / unit	②
Input / transducer block 1 / working range / start-of-scale value	②
Input / transducer block 1 / working range / full-scale value	②
Input / transducer block 1 / characteristic / low-flow cut-off	②
Input / transducer block 1 / characteristic / start of root function	②
Input / transducer block 1 / interpolation points (all settings)	②
Input / transducer block 1 / sensor temperature / temperature unit	②
Output / Function Block 1 - analog input (all settings)	②
Output / Function Block 2 - totalizer (all settings)	②
Display and user interface / local operation	②
Display and user interface / source for display	②
Display and user interface / decimal places in display	②
Diagnostics settings / enabling of diagnostics	②
Diagnostics settings / calibration interval for application electronics (all settings)	②

Parameter name in SIMATIC PDM	Status of user data following replacement of application electronics or measuring cell
* Sensor calibration	②
* Position error calibration	②
* Write block	②
* Operating hours counter, application electronics	②
* Min/max pointers for electronics temperature	②

5.7 Replacing parts

5.7.1 Guarantee information

Following replacement of a part, a guarantee is only valid for the individual components and not for the complete device.

5.7.2 Exploded view of the device

Depending on a customer-specific order, the device comprises different parts. The next chapters show you how to replace the components.

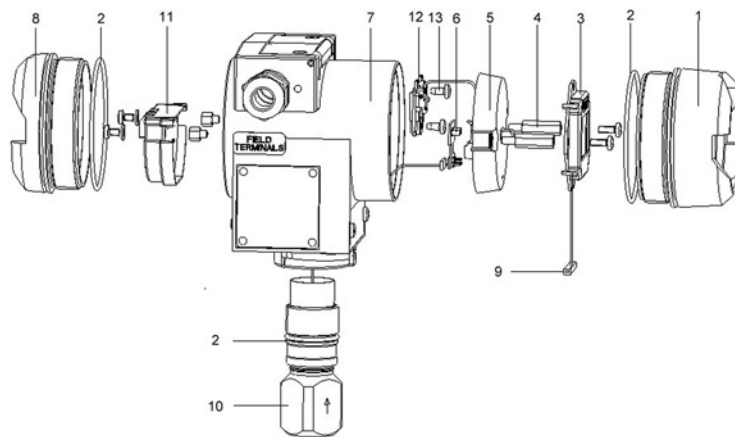

- | | | | |
|---|--|----|--|
| 1 | Cover (front), optionally with inspection window | 8 | Cover (rear) for electronic terminal compartment |
| 2 | O-ring between the cover and housing | 9 | Connection for digital display |
| 3 | Display (optional) | 10 | Measuring cell |
| 4 | Threaded bolts | 11 | Connection board |
| 5 | Application electronics | 12 | Keyboard PCB |
| 6 | Measuring cell PCB | 13 | Mounting screws |
| 7 | Housing | | |

Figure 5-1 Exploded view of the transmitter

5.7.3 Replacing the connection board

Procedure for replacing the connection board

1. Isolate the device from power.
2. Use a 3 mm Allen key to loosen the cover.
3. Open the cover (rear) of the electronic connection compartment.



4. Disconnect the cables from the connection board.
5. On the left and right side, remove the recessed-head screws that hold the connection board to the enclosure.

6. Make sure when loosening the recessed-head screws that the washers (serrated washers) are not lost.



7. Remove the connection board.



To install the connection board, proceed as follows

1. Insert the new connection board so that its contact pins on rear side mate the contacts in the housing.



2. Work in the reverse order as described in "Procedure for replacing the connection board".
3. Close the device as described in Chapter Closing the device (Page 26).

5.7.4 Replacing the pushbutton module

1. Isolate the device from power.
2. In order to open the pushbutton flap, loosen the two recessed-head screws on the outside.



3. Remove the two splints on the pushbutton flap using flat-nose pliers.



4. Remove the pushbutton flap.
5. Use a TX10 Torx screwdriver or Phillips screwdriver to loosen the two screws of the pushbutton insert you can now see.



6. Remove the pushbutton insert from the housing.



7. Remove the three keys with springs from the pushbutton insert.

Procedure for installing the pushbutton module

1. Work in the reverse order as described in "Procedure for replacing the pushbutton module".
2. When inserting the new pushbutton module, make sure that the magnets of the keys point to the front in the direction of the display.

5.7.5 Replacing the display

Procedure for replacing the display

1. Open the front cover (optional with inspection window).
2. Remove the recessed-head screws on the left and right on the display.



3. Pull the display out of the housing.



4. Remove the connector of the ribbon cable from the application electronics.



Procedure for installing the display

1. You can also turn the mounting position of the display by 90 ° or 180 °.
2. Work in the reverse order as described in "Procedure for replacing the display".
3. Close the device as described in Chapter Closing the device (Page 26).

5.7.6 Replacing the application electronics

Procedure for replacing the application electronics

1. Isolate the device from power.
2. Remove the display. Compare section Replacing the display (Page 45).
3. Use a 7 mm socket wrench to remove the hexagon stud bolts on the left and right.



4. Remove the application electronics.



5. Remove the measuring cell PCB from the application electronics. To do this, carefully release the clip using a screwdriver as shown in the following picture.

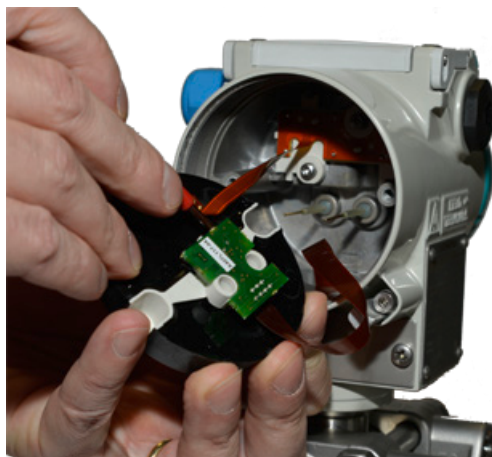

5.7 Replacing parts

6. Use a TX9 Torx screwdriver or Phillips screwdriver to unscrew the two screws of the keyboard PCB you can now see from the base of the housing.



7. Remove the keyboard PCB.

Procedure for installing the application electronics

NOTICE
Frequent insertion of the measuring cell PCB Device damage. <ul style="list-style-type: none">• Avoid frequent insertion of the measuring cell PCB.

1. Work in the reverse order as described in "Procedure for replacing the application electronics".
2. When inserting the new application electronics, make sure that the contact pins fit in the rear of the application electronics.
The ribbon cable of the measuring cell should be positioned between the contact pins, and that of the keyboard PCB on the left of the pins.
3. Do not kink, pinch, tension or twist the ribbon cable when plugging it onto the application electronics.
4. Close the device as described in Chapter Closing the device (Page 26).
5. Following a replacement, permanently obliterate the firmware ID on the nameplate if applicable.
6. Write the new firmware ID on the nameplate.
7. Calibrate the zero point of the device, and also the span if necessary. Calibration of the span is necessary if the device was matched e.g. to a control system prior to replacement of the application electronics. Compare section Technical specifications (Page 55).

5.7.7 Replacing the measuring cell

Procedure for replacing the measuring cell

Note

When using the differential pressure cell, replace the complete measuring cell with process flanges.

1. Isolate the device from power.
2. Remove the display. Compare section Replacing the display (Page 45).
3. Remove the application electronics. Compare section Replacing the application electronics (Page 47).



4. Use a 2.5 mm Allen key to loosen the locking screw for fixing the measuring cell.



NOTICE

Damage to the ribbon cable

To avoid damage to the ribbon cable when installing or removing the measuring cell, do not kink, pinch, tension or twist it.

- Do not kink, pinch, tension or twist the ribbon cable.

5. Turn the measuring cell counter-clockwise to remove it from the housing. To do this, use a matching open-end wrench (relative pressure transmitter) or rotate the measuring cell by hand.



Procedure for installing the measuring cell

1. Clean residues off the thread of the housing.
2. Push the measuring cell PCB through the threaded hole.
3. Turn the measuring cell into the housing until an overhang of $2.6 \text{ mm} \pm 0.75$ remains.

The ribbon cable must be present as a loop between the two feed-through pins, and must follow every rotation of the cell.

Make sure that the mounting flange is correctly orientated on the differential pressure cell. The arrow ② must remain visible within the marked area ①.

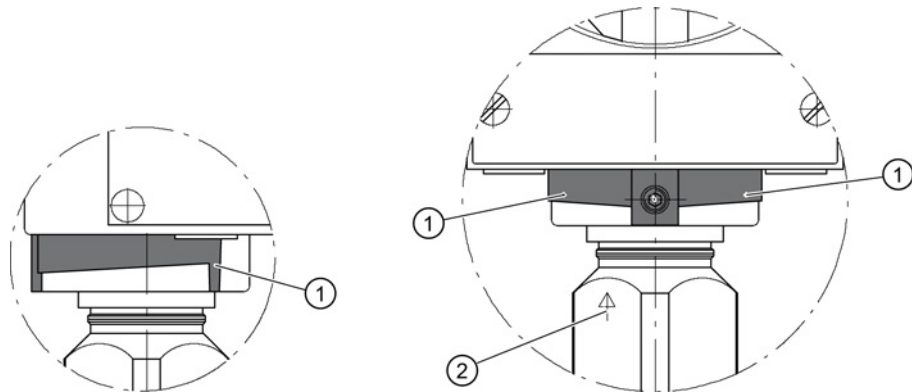

4. Work from here on in the reverse order as described in "Procedure for replacing the measuring cell".
5. Close the device as described in Chapter Closing the device (Page 26).
6. Following a replacement, permanently obliterate the hardware ID on the nameplate if applicable.
7. Write the new hardware ID on the nameplate.
8. Following replacement of the measuring cell, carry out an insulation test between the short-circuited input terminals and the protective earth connection. The insulation resistance should have a value greater than 10 MOhm.

5.8 Cleaning

WARNING

Dust layers above 5 mm

Danger of explosion in hazardous areas. Device may overheat due to dust build up.

- Remove dust layers in excess of 5 mm.

NOTICE
Penetration of moisture into the device Device damage. <ul style="list-style-type: none">• Make sure when carrying out cleaning and maintenance work that no moisture penetrates the inside of the device.

Cleaning the enclosure

- Clean the outside of the enclosure and the display window using a cloth moistened with water or a mild detergent.
- Do not use aggressive cleaning agents or solvents. Plastic components or painted surfaces could be damaged.

 WARNING
Electrostatic charge Danger of explosion in hazardous areas if electrostatic charges develop, for example, when cleaning plastic enclosures with a dry cloth. <ul style="list-style-type: none">• Prevent electrostatic charging in hazardous areas.

5.8.1 Servicing the remote seal measuring system

The remote seal measuring system usually does not need servicing.

If the mediums are contaminated, viscous or crystallized, it could be necessary to clean the diaphragm from time to time. Use only a suitable solvent to remove the deposits from the diaphragm. Do not use corrosive cleaning agents. Prevent the diaphragm from getting damaged due to sharp-edged tools.

NOTICE
Improper cleaning of diaphragm Device damage. The diaphragm can be damaged. <ul style="list-style-type: none">• Do not use sharp or hard objects to clean the diaphragm.

5.9 Return procedure

Enclose the bill of lading, return document and decontamination certificate in a clear plastic pouch and attach it firmly to the outside of the packaging.

Required forms

- Delivery note
- Return goods delivery note (<http://www.siemens.com/processinstrumentation/returngoodsnote>)
with the following information:
 - Product (item description)
 - Number of returned devices/replacement parts
 - Reason for returning the item(s)
- Decontamination declaration (<http://www.siemens.com/sc/declarationofdecontamination>)

With this declaration you warrant "that the device/replacement part has been carefully cleaned and is free of residues. The device/replacement part does not pose a hazard for humans and the environment."

If the returned device/replacement part has come into contact with poisonous, corrosive, flammable or water-contaminating substances, you must thoroughly clean and decontaminate the device/replacement part before returning it in order to ensure that all hollow areas are free from hazardous substances. Check the item after it has been cleaned.

Any devices/replacement parts returned without a decontamination declaration will be cleaned at your expense before further processing.

The forms can be found on the Internet as well as in the documentation which comes with the device.

5.10 Disposal



Devices identified by this symbol may not be disposed of in the municipal waste disposal services under observance of the Directive 2002/96/EC on waste electronic and electrical equipment (WEEE).

They can be returned to the supplier within the EC or to a locally approved disposal service. Observe the specific regulations valid in your country.

Note

Special disposal required

The device includes components that require special disposal.

- Dispose of the device properly and environmentally through a local waste disposal contractor.
-

Technical specifications

This chapter describes the deviations from the technical specifications in the operating instructions.

Deviations exist as follows in the measuring accuracy following replacement of the application electronics or measuring cell:

Table 6- 1 Technical specifications > measuring accuracy

SITRANS P DS III with HART	No calibration of zero and span	Calibration of zero and span
Measurement deviation with limit setting, including hysteresis and repeatability		
Linear characteristic curve		
• $r \leq 10$	Value doubled	Value remains unchanged
Effect of ambient temperature		
• At -10 ... +60 °C (14 ... 140 °F)	Value doubled	Value doubled

r = maximum measuring span/set measuring span

Ordering data for spare parts/accessories

Selection and Ordering data	Article No.	Selection and Ordering data	Article No.
Replacement measuring cell for pressure for SITRANS P DS III	7 MF 4 9 9 0 - 0 - 0 DB 0	Replacement measuring cell for absolute pressure for SITRANS P DS III (from the pressure series)	7 MF 4 9 9 2 - 0 - 0 DB 0
Measuring cell filling Measuring cell cleaning Silicone oil Normal Inert liquid grease-free to cleanliness level 2	1 3	Measuring cell filling Measuring cell cleaning Silicone oil Normal Inert liquid grease-free to cleanliness level 2	1 3
Measured span (min. ... max.)		Measured span (min. ... max.)	
0.01 ... 1 bar (0.15 ... 14.5 psi)	B	8.3 ... 250 mbar a (0.12 ... 3.62 psia)	D
0.04 ... 4 bar (0.6 ... 58 psi)	C	43 ... 1300 mbar a (0.62 ... 18.85 psia)	F
0.16 ... 16 bar (2.32 ... 232 psi)	D	0.16 ... 5 bar a (2.32 ... 72.5 psia)	G
0.63 ... 63 bar (9.14 ... 914 psi)	E	1 ... 30 bar a (14.5 ... 435 psia)	H
1.6 ... 160 bar (23.2 ... 2320 psi)	F		
4.0 ... 400 bar (58.0 ... 5802 psi)	G		
7.0 ... 700 bar (102.0 ... 10153 psi)	J		
Wetted parts materials		Wetted parts materials	
Seal diaphragm Process connection		Seal diaphragm Process connection	
Stainless steel Stainless steel	A	Stainless steel Stainless steel	A
Hastelloy Stainless steel	B	Hastelloy Stainless steel	B
Hastelloy Hastelloy	C	Hastelloy Hastelloy	C
Process connection		Process connection	
• Connection shank G $\frac{1}{2}$ B to EN 837-1	0	• Connection shank G $\frac{1}{2}$ B to EN 837-1	0
• Female thread $\frac{1}{2}$ -14 NPT	1	• Female thread $\frac{1}{2}$ -14 NPT	1
• Oval flange made of stainless steel, max. span 160 bar (2320 psi)		• Oval flange made of stainless steel, max. span 160 bar (2320 psi)	
- Mounting thread $\frac{7}{16}$ -20 UNF to IEC 61518	2	- Mounting thread $\frac{7}{16}$ -20 UNF to IEC 61518	2
- Mounting thread M10 to DIN 19213	3	- Mounting thread M10 to DIN 19213	3
Further designs	Order code	Further designs	Order code
Please add "-Z" to Article No. and specify Order code.		Please add "-Z" to Article No. and specify Order code.	
Inspection certificate to EN 10204-3.1	C12	Inspection certificate to EN 10204-3.1	C12

Selection and Ordering data	Article No.
Replacement measuring cell for absolute pressure (from the differential pressure series) for SITRANS P DS III with HART, DS III with PROFIBUS PA and DS III with FOUNDATION Fieldbus series	7MF 4 9 9 3 - - 0 DC 0
Measuring cell filling Measuring cell cleaning Silicone oil Normal Inert liquid grease-free to cleanliness level 2	1 3
Measured span (min. ... max.) 8.3 ... 250 mbar a (0.12 ... 3.62 psia) 43 ... 1300 mbar a (0.62 ... 18.85 psia) 0.16 ... 5 bar a (2.32 ... 72.5 psia) 1 ... 30 bar a (14.5 ... 435 psia) 5.3 ... 100 bar a (76.9 ... 1450 psia)	D F G H K E
Wetted parts materials Seal diaphragm Parts of measuring cell	A B C E H L
Stainless steel Stainless steel Hastelloy Stainless steel Hastelloy Hastelloy Tantalum Tantalum Monel Monel Gold Gold	A B C E H L
Process connection Female thread 1/4-18 NPT with flange connection • Sealing screw opposite process connection - Mounting thread M10 to DIN 19213 - Mounting thread 7/16-20 UNF to IEC 61518 • Vent on side of process flange ¹⁾ - Mounting thread M10 to DIN 19213 - Mounting thread 7/16-20 UNF to IEC 61518	0 2 4 6
Non-wetted parts materials • Stainless steel process flange screws	2
Further designs Please add " -Z" to Article No. and specify Order code.	Order code
O-rings for process flanges (instead of FPM (Viton)) • PTFE (Teflon) • FEP (with silicone core, approved for food) • FFPM (Kalrez, compound 4079) • NBR (Buna N)	A20 A21 A22 A23
Inspection certificate to EN 10204-3.1	C12
Process connection G1/2B	D16
Remote seal flanges (not together with K01, K02 and K04)	D20
Vent on side for gas measurements	H02
Process flanges • without • with process flange made of - Hastelloy - Monel - Stainless steel with PVDF insert max. PN 10 (MAWP 145 psi) max. temperature of medium 90 °C (194 °F) For 1/2-14 NPT inner process connection on the side in the middle of the process flange, vent valve not possible	K00 K01 K02 K04

¹⁾ Not for span "5.3 ... 100 bar (76.9 ... 1450 psi)"

Selection and Ordering data	Article No.
Replacement measuring cell for differential pressure and PN 32/160 (MAWP 464/2320 psi) for SITRANS P DS III with HART, DS III with PROFIBUS PA and DS III with FOUNDATION Fieldbus series	7MF 4 9 9 4 - - 0 DC 0
Measuring cell filling Measuring cell cleaning Silicone oil Normal Inert liquid grease-free to cleanliness level 2	1 3
Measured span (min. ... max.) PN 32 (MAWP 464 psi) 1 ... 20 mbar ¹⁾ (0.4 ... 8 inH ₂ O) PN 160 (MAWP 2320 psi) 1 ... 60 mbar (0.4 ... 24 inH ₂ O) 2.5 ... 250 mbar (1 ... 100 inH ₂ O) 6 ... 600 mbar (2.4 ... 240 inH ₂ O) 16 ... 1600 mbar (6.4 ... 642 inH ₂ O) 50 ... 5000 mbar (20 ... 2000 inH ₂ O) 0.3 ... 30 bar (4.35 ... 435 psi)	B C D E F G H
Wetted parts materials (stainless steel process flanges) Seal diaphragm Parts of measuring cell	A B C E H L
Stainless steel Stainless steel Hastelloy Stainless steel Hastelloy Hastelloy Tantalum ²⁾ Tantalum Monel ²⁾ Monel Gold ²⁾ Gold	A B C E H L
Process connection Female thread 1/4-18 NPT with flange connection • Sealing screw opposite process connection - Mounting thread M10 to DIN 19213 - Mounting thread 7/16-20 UNF to IEC 61518 • Vent on side of process flange - Mounting thread M10 to DIN 19213 - Mounting thread 7/16-20 UNF to IEC 61518	0 2 4 6
Non-wetted parts materials Stainless steel process flange screws	2
Further designs Please add " -Z" to Article No. and specify Order code.	Order code
O-rings for process flanges (instead of FPM (Viton)) • PTFE (Teflon) • FEP (with silicone core, approved for food) • FFPM (Kalrez, compound 4079) • NBR (Buna N)	A20 A21 A22 A23
Inspection certificate to EN 10204-3.1	C12
Remote seal flanges (not together with K01, K02 and K04)	D20
Vent on side for gas measurements	H02
Stainless steel process flanges for vertical differential pressure lines (not together with K01, K02 and K04)	H03
Process flanges • without • with process flange made of - Hastelloy - Monel - Stainless steel with PVDF insert max. PN 10 (MAWP 145 psi) max. temperature of medium 90 °C (194 °F) For 1/2-14 NPT inner process connection on the side in the middle of the process flange, vent valve not possible	K00 K01 K02 K04

¹⁾ Not suitable for connection of remote seal

²⁾ Only together with max. spans 250, 1600, 5000 and 30000 mbar (100 inH ₂O, 642 inH ₂O, 2000 inH ₂O und 435 psi).

Selection and Ordering data		Article No.
Replacement measuring cell for differential pressure and PN 420 (MAWP 6092 psi) for SITRANS P DS III with HART, DS III with PROFIBUS PA and DS III with FOUNDATION Fieldbus series		7 MF 4 9 9 5 - - 0 DC 0
Measuring cell filling	Measuring cell cleaning	1
Silicone oil	Normal	
Measured span (min. ... max.)		
2.5 ... 250 mbar	(1 ... 100 inH ₂ O)	D
6 ... 600 mbar	(2.4 ... 240 inH ₂ O)	E
16 ... 1600 mbar	(6.4 ... 642 inH ₂ O)	F
50 ... 5000 mbar	(20 ... 2000 inH ₂ O)	G
0.3 ... 30 bar	(4.35 ... 435 psi)	H
Wetted parts materials (stainless steel process flanges)		
Seal diaphragm	Parts of measuring cell	
Stainless steel	Stainless steel	A
Hastelloy	Stainless steel	B
Gold ¹⁾	Gold	L
Process connection		
Female thread 1/4-18 NPT with flange connection		
• Sealing screw opposite process connection		
- Mounting thread M12 to DIN 19213		1
- Mounting thread 7/16-20 UNF to IEC 61518		3
• Vent on side of process flange		
- Mounting thread M12 to DIN 19213		5
- Mounting thread 7/16-20 UNF to IEC 61518		7
Non-wetted parts materials		
• Stainless steel process flange screws		2
Further designs		Order code
Please add "Z" to Article No. and specify Order code.		
O-rings for process flanges (instead of FPM (Viton))		
• PTFE (Teflon)		A20
• FEP (with silicone core, approved for food)		A21
• FFPM (Kalrez, compound 4079)		A22
• NBR (Buna N)		A23
Inspection certificate to EN 10204-3.1		C12
Stainless steel process flanges for vertical differential pressure lines		H03
without process flanges		K00

¹⁾ Not together with max. span 600 mbar (240.9 inH₂O)

Selection and Ordering data		Article No.
Replacement measuring cell for differential pressure and PN 420 (MAWP 6092 psi) for SITRANS P DS III with HART, DS III with PROFIBUS PA and DS III with FOUNDATION Fieldbus series		7MF 4995 - - 0 DC 0
Measuring cell filling Silicone oil	Measuring cell cleaning Normal	1
Measured span (min. ... max.)		
2.5 ... 250 mbar	(1 ... 100 inH ₂ O)	D
6 ... 600 mbar	(2.4 ... 240 inH ₂ O)	E
16 ... 1600 mbar	(6.4 ... 642 inH ₂ O)	F
50 ... 5000 mbar	(20 ... 2000 inH ₂ O)	G
0.3 ... 30 bar	(4.35 ... 435 psi)	H
Wetted parts materials (stainless steel process flanges)		
Seal diaphragm	Parts of measuring cell	
Stainless steel	Stainless steel	A
Hastelloy	Stainless steel	B
Gold ¹⁾	Gold	L
Process connection Female thread ¼-18 NPT with flange connection		
• Sealing screw opposite process connection		
- Mounting thread M12 to DIN 19213		1
- Mounting thread 7/16-20 UNF to IEC 61518		3
• Vent on side of process flange		
- Mounting thread M12 to DIN 19213		5
- Mounting thread 7/16-20 UNF to IEC 61518		7
Non-wetted parts materials		
• Stainless steel process flange screws		2
Further designs		Order code
Please add "-Z" to Article No. and specify Order code.		
O-rings for process flanges (instead of FPM (Viton))		
• PTFE (Teflon)		A20
• FEP (with silicone core, approved for food)		A21
• FFPM (Kalrez, compound 4079)		A22
• NBR (Buna N)		A23
Inspection certificate to EN 10204-3.1		C12
Stainless steel process flanges for vertical differential pressure lines		H03
without process flanges		K00

¹⁾ Not together with max. span 600 mbar (240.9 inH₂O)

Selection and Ordering data	Article No.	Selection and Ordering data	Article No.
<i>Spare parts/Accessories</i>			
Mounting bracket and fastening parts for pressure transmitters SITRANS P DS III with HART, DS III with PROFIBUS PA and DS III with FOUNDATION Fieldbus (7MF403-.....-C.) For absolute pressure transmitters SITRANS P DS III with HART, DS III with PROFIBUS PA and DS III with FOUNDATION Fieldbus (7MF423-.....-C.) • made of steel • made of stainless steel	7MF4997-1AB 7MF4997-1AH	Mounting screws For measuring point label, grounding and connection terminals or for display (50 units)	7MF4997-1CD
Mounting bracket and fastening parts for pressure transmitters SITRANS P DS III with HART, DS III with PROFIBUS PA and DS III with FOUNDATION Fieldbus (7MF403-.....-A., ..-B., ..-D. and ..-F.) For absolute pressure transmitters SITRANS P DS III with HART, DS III with PROFIBUS PA and DS III with FOUNDATION Fieldbus (7MF423-.....-A., ..-B., ..-D. and ..-F.) • made of steel • made of stainless steel	7MF4997-1AC 7MF4997-1AJ	Sealing screws (1 set = 2 units) for process flange • made of stainless steel • made of Hastelloy	7MF4997-1CG 7MF4997-1CH
Mounting and fastening brackets For differential pressure transmitters with flange thread M10 SITRANS P DS III with HART, DS III with PROFIBUS PA and DS III with FOUNDATION Fieldbus (7MF433-..... and 7MF443-.....) • made of steel • made of stainless steel	7MF4997-1AD 7MF4997-1AK	Sealing screws with vent valve Complete (1 set = 2 units) • made of stainless steel • made of Hastelloy	7MF4997-1CP 7MF4997-1CQ
Mounting and fastening brackets For differential pressure transmitters with flange thread M12 SITRANS P DS III with HART, DS III with PROFIBUS PA and DS III with FOUNDATION Fieldbus (7MF453-.....) • made of steel • made of stainless steel	7MF4997-1AE 7MF4997-1AL	Electronics • for SITRANS P DS III with HART • for SITRANS P DS III with PROFIBUS PA • for SITRANS P DS III with FOUNDATION Fieldbus	7MF4997-1DK 7MF4997-1DL 7MF4997-1DM
Mounting and fastening brackets For differential and absolute pressure transmitters with flange thread 7/16 -20 UNF SITRANS P DS III with HART, DS III with PROFIBUS PA and DS III with FOUNDATION Fieldbus (7MF433-....., 7MF443-..... and 7MF453-.....) • made of steel • made of stainless steel	7MF4997-1AF 7MF4997-1AM	Connection board • for SITRANS P DS III • for SITRANS P DS III PROFIBUS PA and FOUNDATION Fieldbus	7MF4997-1DN 7MF4997-1DP
Cover made of die-cast aluminum, including gasket, for SITRANS P DS III with HART, DS III with PROFIBUS PA and DS III with FOUNDATION Fieldbus • without window • with window	7MF4997-1BB 7MF4997-1BE	O-rings for process flanges made of: • FPM (Viton) • PTFE (Teflon) • FEP (with silicone core, approved for food) • FFFPM (Kalrez, compound 4079) • NBR (Buna N)	7MF4997-2DA 7MF4997-2DB 7MF4997-2DC 7MF4997-2DD 7MF4997-2DE
Cover made of stainless steel, including gasket, for SITRANS P DS III with HART, DS III with PROFIBUS PA and DS III with FOUNDATION Fieldbus • without window • with window	7MF4997-1BC 7MF4997-1BF	Sealing ring for process connection	see "Fittings"
Digital indicator Including mounting material for SITRANS P DS III with HART, DS III with PROFIBUS PA and DS III with FOUNDATION Fieldbus	7MF4997-1BR	Weldable sockets for PMC connection • PMC Style Standard: Thread 1½" • PMC Style Minibolt: front-flush 1"	7MF4997-2HA 7MF4997-2HB
Measuring point label • without inscription (5 units) • Printed (1 unit) Data according to Y01 or Y02, Y15, Y16 and Y99 (see "Pressure transmitters")	7MF4997-1CA 7MF4997-1CB-Z Y.:	Gaskets for PMC connection (packing unit = 5 units) • PTFE seal for PMC Style Standard: Thread 1½" • Gasket made of Viton for PMC Style Minibolt: front-flush 1"	7MF4997-2HC 7MF4997-2HD
		Weldable socket for TG52/50 and TG52/150 connection • TG52/50 connection • TG52/150 connection	7MF4997-2HE 7MF4997-2HF
		Seals for TG 52/50 and TG 52/150 made of silicone (FDA compliant)	7MF4997-2HG
		Seals for flange connection with front-flush diaphragm Material FPM (Viton), 10 units • DN 25, PN 40 (M11) • DN 25, PN 100 (M21) • 1", class 150 (M40) • 1", class 300 (M45)	7MF4997-2HH 7MF4997-2HJ 7MF4997-2HK 7MF4997-2HL
		▶ Available ex stock	

Selection and Ordering data	Article No.
Operating Instructions ¹⁾	
• for SITRANS DS III with HART	
- German	A5E00047090
- English	A5E00047092
- French	A5E00053218
- Spanish	A5E00053219
- Italian	A5E00053220
• for SITRANS DS III with PROFIBUS PA	
- German	A5E00053275
- English	A5E00053276
- French	A5E00053277
- Spanish	A5E00053278
- Italian	A5E00053279
• for SITRANS DS III with FOUNDATION Fieldbus	
- German	A5E00279629
- English	A5E00279627
Compact operating instructions The compact operating instructions are available in 21 EU languages on the product CD supplied with each transmitter. They can also be downloaded from the SITRANS P web page.	
Brief instruction (Leporello) German, English	
• for SITRANS DS III with HART	A5E00047093
- German, English	
• for SITRANS DS III with PROFIBUS PA	A5E00053274
- German, English	
• for SITRANS DS III with FOUNDATION Fieldbus	A5E00282355
- German, English	
CD with SITRANS P documentation German, English, French, Spanish, Italian incl. compact operating instructions in 21 EU languages	A5E00090345
Certificates (order only via SAP) instead of Internet download	
• hard copy (to order)	A5E03252406
• on CD (to order)	A5E03252407
Operating Instructions for replacement of electronics, measuring cell and connection board (only available from the Internet) ¹⁾	A5E00078060
HART modem	
• with RS232 interface ▶	7MF4997-1DA
• with USB interface ▶	7MF4997-1DB
Supplementary electronics for 4-wire connection	See page 1/159

▶ Available ex stock

Power supply units see Chap. 7 "Supplementary Components".

¹⁾ You can download these operating instructions free-of-charge from our Internet site at www.siemens.com/sitransp.

See also

Process instrumentation catalog (<http://www.siemens.com/processinstrumentation/catalogs>)

Appendix

A.1 Certificate

The certificates can be found on the enclosed CD and on the Internet under:

Certificates (<http://www.siemens.com/processinstrumentation/certificates>)

A.2 Technical support

Technical Support

You can contact Technical Support for all IA and DT products:

- Via the Internet using the **Support Request:**
Support request (<http://www.siemens.com/automation/support-request>)
- E-mail (<mailto:support.automation@siemens.com>)
- **Phone:** +49 (0) 911 895 7 222
- **Fax:** +49 (0) 911 895 7 223

Further information about our technical support is available on the Internet at
Technical Support (<http://www.siemens.com/automation/csi/service>)

Industry Online Support

In addition to our documentation, we offer a comprehensive knowledge base on the Internet at:

Services & Support (<http://www.siemens.com/automation/service&support>)

There you will find:

- The latest product information, FAQs, downloads, tips and tricks.
- Our newsletter with the latest information about our products.
- A Knowledge Manager to find the right documents for you.
- Our bulletin board, where users and specialists share their knowledge worldwide.
- Your local contact partner for Industry Automation and Drives Technologies in our partner database.
- Information about field service, repairs, spare parts and lots more under "Services."

Additional Support

Please contact your local Siemens representative and offices if you have any questions about the products described in this manual and do not find the right answers.

Find your contact partner at:

Partner (<http://www.automation.siemens.com/partner>)

Documentation for various products and systems is available at:

Instructions and manuals (<http://www.siemens.com/processinstrumentation/documentation>)

See also

Product information on SITRANS P in the Internet (<http://www.siemens.com/sitransp>)

Process instrumentation catalog (<http://www.siemens.com/processinstrumentation/catalogs>)

A.3 Repair report for installation of spare parts

For your local documentation	
Check mark the relevant items and fill out the fields	
1. Customer information:	
Company:	
Address:	
Department:	
Tel / Fax:	
E-mail:	
System part:	
2. Information on the original device: first replacement of a component <input type="checkbox"/>	
Electronic serial number:	
Sensor serial number:	
F-no.: (rating plate)	
HW: Approval plate)	
FW: (approval plate)	
Device order no.:	7MF4 _ _ _ _ - _ _ _ _ - _ _ _ _ - Z _ _ _
Additional components	- Z _ _ _ - Z _ _ _ - Z _ _ _ - Z _ _ _ - Z _ _ _ - Z _ _ _ - Z _ _ _ - Z _ _ _ - Z _ _ _ - Z _ _ _
3a. Device information Spare Part(1): Measuring cell	
Sensor serial number:	
Spare part order no.:	7MF499 _ - _ _ _ _ - Z _ _ _
Additional components	- Z _ _ _ - Z _ _ _ - Z _ _ _ - Z _ _ _ - Z _ _ _ - Z _ _ _ - Z _ _ _ - Z _ _ _ - Z _ _ _ - Z _ _ _
3b. Device information Spare Part(2): Application electronics	
Electronic serial number:	
ES: (electronic cup)	
FW: (electronic cup)	
Spare part order no.:	7MF4999 - _ _ _ _ - _ _ _ _
3c. Device information Spare Part(3): Connection board	
HW: (connection board)	
Spare part order no.:	7MF4999 - _ _ _ _ - _ _ _ _
3d. Device information Spare Part(4): Pushbutton module	
HW: (connection board)	
Spare part order no.:	7MF4999 - _ _ _ _ - _ _ _ _
3e. Device information Spare Part(5): Display	
HW: (connection board)	
Spare part order no.:	7MF4999 - _ _ _ _ - _ _ _ _
3f. Device information Spare Part(6): Additional spare parts	
HW: (connection board)	
Spare part order no.:	7MF4999 - _ _ _ _ - _ _ _ _
4. Additional information	
Installation location (precise definition)	

For your local documentation	
Repair period:	From:
	To:
Safety measures:	
Work completed:	
5. Approval	
Check mark the relevant items and fill out the fields	
Replacement documentation was read and observed: <input type="checkbox"/>	
ESD guidelines were observed: <input type="checkbox"/>	
Inspected by Ex expert: <input type="checkbox"/>	
Function test completed: <input type="checkbox"/>	
Name of Ex expert:	Date:
Signature of Ex expert:	
Author name:	Date:
Author signature:	

Glossary

ATEX

ATEX is an abbreviation of the French term "Atmosphère explosible" (potentially explosive atmosphere). ATEX stands for both EC directives in the area of explosion protection: ATEX product directive 94/9/EC and ATEX operating directive 1999/92/EC.

Auxiliary power supply

Auxiliary power supply refers to an electrical supply or reference voltage which some electrical circuits require apart from the standard supply. The auxiliary power supply can, for example, be specially stabilized, have a particular level or polarity and/or other properties which are important for the correct functioning of switch components.

Auxiliary voltage

→ *Auxiliary power supply*

Dangerous failure

Failure with the potential to switch a safety-instrumented system to a hazardous or non-functioning safety state.

EEPROM

EEPROM (Electrically Erasable Programmable Read-Only Memory): a non-volatile, electronic memory module.

EEPROMs are often used where individual bytes of data (e.g. configuration data or runtime meters) change over time and must be stored safely in the event of a mains power failure.

Failure/Fault/Error

Failure:

A resource is no longer capable of executing a required function.

Fault/Error:

Undesired state of a resource indicated by its incapability of executing a required function.

Fault/Error

→ *Failure/Fault/Error*

Final controlling element

Converter that converts electrical signals into mechanical or other non-electric variables.

Firmware

Firmware (FW) is software that is embedded on a chip in electronic devices – in contrast to software which is saved on hard disks, CD-ROMs or other media. These days, firmware is mostly stored in a flash memory or EEPROM.

Firmware usually contains the elementary functions for controlling the device, as well as input and output routines.

Frequency shift keying

Frequency shift keying is a simple form of modulation, where the digital values 0 and 1 modulate the actual current signal by means of two different frequencies.

Frequency Shift Keying (FSK)

→ *Frequency shift keying*

HART

HART (Highway Addressable Remote Transducer) is a standardized, widely used communications system used to structure industrial fieldbuses. The communications system provides digital communications for multiple participants (field devices) via a common databus. HART is based especially on the equally widely used 4/20 mA standard for the transfer of analog sensor signals. The cabling from existing older systems can be used directly and both systems operated in parallel.

HART specifies several protocol levels in the OSI model. It facilitates the transfer of process and diagnostics data and control signals between field devices and high-level control systems. Standardized parameter sets can be used for the manufacture-independent operation of all HART devices.

Typical applications include transmitters for measuring mechanical and electrical dimensions.

MAWP (PS)

Maximum Allowable Working Pressure (PS)

Non-volatile memory

→ *EEPROM*

Risk

Combination of the probability of damage occurring and the extent of the damage.

Safety function

Defined function executed by a safety-instrumented system with the objective of attaining or maintaining a safe system state by taking a defined hazardous incident into account.

Example:

Limit pressure monitoring

Safety Integrity Level

→ *SIL*

Safety-instrumented system

A safety-instrumented system (SIS) executes the safety functions that are required to achieve or maintain a safe state in a system. It consists of a sensor, logic unit/control system and final controlling element.

Example:

A safety-instrumented system is made up of a pressure transmitter, a limit signal sensor and a control valve.

Sensor

Converter that converts mechanical or other non-electric variables into electrical signals.

SIL

The international standard IEC 61508 defines four discrete safety integrity levels (SIL) from SIL 1 to SIL 4. Each level corresponds to a probability range for the failure of a safety function. The higher the SIL of the safety-instrumented system, the higher the probability that the required safety function will work.

The SIL which can be achieved is determined by the following safety-instrumented characteristics:

- Average probability of failure on demand (PFD_{AVG})
- Hardware fault tolerance (HFT)
- Safe failure fraction (SFF)

srl2

→ *srlin2*

srlin2

"srli2" or "srlin2" is a type of square root extracting characteristic curve for the output current. This characteristic curve type is proportional to the flow rate, linear in two levels up to the application point and has a pre-defined application point of 10%.

"srli2" or "srlin2" are synonymous and technically there is no difference between them. The abbreviation "srli2" is used in sections that refer to the on-site operation of the pressure transmitter. The reason for the abbreviation is that the pressure transmitter display is restricted to five characters. The abbreviation "srlin2" is used for HART operation.

Index

A

Additional Support, 66
Approval plate,

C

Certificate, 65
Certificates, 15
Certification, 65
Correct usage,
Customer Support Hotline, 65

D

Device
Electrostatic-sensitive, 32

E

Electrostatic-sensitive device (ESD), 32

F

Firmware, 7

H

Hazardous area
Laws and directives, 15
History, 7
Hotline, 65

I

Improper device modifications, 15
Internet, 65

N

Nameplate, 20
Nameplate with general information, 20

P

Process connection, 20

Q

Qualified personnel, 16

R

Remote seal
Maintenance, 52

S

Scope of delivery, 8
Service, 65
Structure, 19
Support, 65

T

Test certificates, 15

Get more information

www.siemens.com/processautomation

www.siemens.com/sitransp

Siemens AG
Industry Sector
Postfach 48 48
90026 NÜRNBERG
GERMANY

Subject to change without prior notice
A5E34219855-01
© Siemens AG 2014



A5E34219855



A5E34219855

www.siemens.com/automation