

## GROUP 52B

# SUPPLEMENTAL RESTRAINT SYSTEM (SRS)

## CONTENTS

<b>GENERAL INFORMATION</b> .....	<b>52B-2</b>	SIDE-AIRBAG MODULE .....	52B-13
<b>SYSTEM OPERATION</b> .....	<b>52B-10</b>	CURTAIN AIR BAG MODULE .....	52B-14
ADVANCED AIR BAG AND SEAT BELT WITH PRE-TENSIONER .....	52B-10	FRONT IMPACT SENSOR .....	52B-14
SIDE AND CURTAIN AIR BAGS .....	52B-11	SIDE IMPACT SENSOR .....	52B-14
<b>SYSTEM CONSTRUCTION</b> .....	<b>52B-11</b>	SEAT SLIDE SENSOR .....	52B-15
DRIVER'S SIDE AIR BAG MODULE .....	52B-11	OCCUPANT CLASSIFICATION-ECU AND WEIGHT SENSOR .....	52B-15
CLOCK SPRING .....	52B-12	SEAT BELT WITH PRE-TENSIONER .....	52B-18
PASSENGER'S (FRONT) AIR BAG MODULE .....	52B-12	PASSENGER SEAT BELT WARNING LIGHT .....	52B-20
KNEE AIR BAG MODULE .....	52B-13	PASSENGER'S AIR BAG OFF INDICATOR LIGHT .....	52B-20
		SRS-ECU .....	52B-21
		SRS AIR BAG SPECIAL CONNECTOR .....	52B-25

## GENERAL INFORMATION

M2521000100994

### CAUTION

- **Driver and passenger's (front) air bags, knee air bag and seat belt pre-tensioner deploy and operate in frontal collisions that exceed the threshold to activate the SRS (Supplemental Restraint System).**
  - **The front air bag deploys when a vehicle collides head-on with a concrete (fixed) wall at approximately 25 km/h (15 mph) or more, or when a vehicle suffers a severe impact from the front side. The side air bag deploys when a center of side body suffers a severe impact.**
  - **The front air bags and pre-tensioner may not work under the following conditions:**
    - **A frontal collision is less than the specific value.**
    - **The collision is from the rear**
    - **The collision is from the side**
    - **The vehicle rolls over or is in a similar position.**
  - **The side-airbags and curtain air bags may not work under the following conditions:**
    - **The collision is from the front**
    - **The collision is from the rear**
  - Driver's and passenger's (front) air bags, side-airbags, knee air bag, curtain air bags and seat belts with pre-tensioner have been installed to all the vehicles as standard.
  - The SRS is a system that is effective with the seat belt fastened, and it is designed as a supplemental system of the seat belt.
- The advanced air bag system has been adopted to the driver's and passenger's (front) sides. When a frontal impact exceeds the threshold upon a frontal collision, or depending on the seat position (driver's seat side), the air bag inflates the cushion air bag in two stages, improving the protection for the front seat passengers.
  - When a frontal impact exceeds the threshold, the knee air bag is instantaneously inflated to protect the passenger's feet (knee and leg).
  - The side-airbag is activated when an impact exceeds the threshold upon a side collision, and the cushion air bag is instantaneously inflated to protect the chest area of the front seat passengers.
  - The curtain air bag is activated simultaneously with the side-airbag upon a side collision to protect the heads of the front seat and second seat passengers.
  - All the air bag modules are equipped with the inflator that does not contain toxic sodium azide.
  - The seat belt pre-tensioner is activated simultaneously with the deployment of driver's and passenger's (front) air bags in case of a frontal collision. Seat belts are pulled in to eliminate the slack upon a collision, thus improving the initial occupant restraint, and reducing the travel distance of the occupants. For the driver's seat, in addition to the seat belt pre-tensioner for the shoulder side, the lap pre-tensioner has been installed on the outer seat belt lower anchor side in order to improve the restraining performance in the waist and the chest areas.

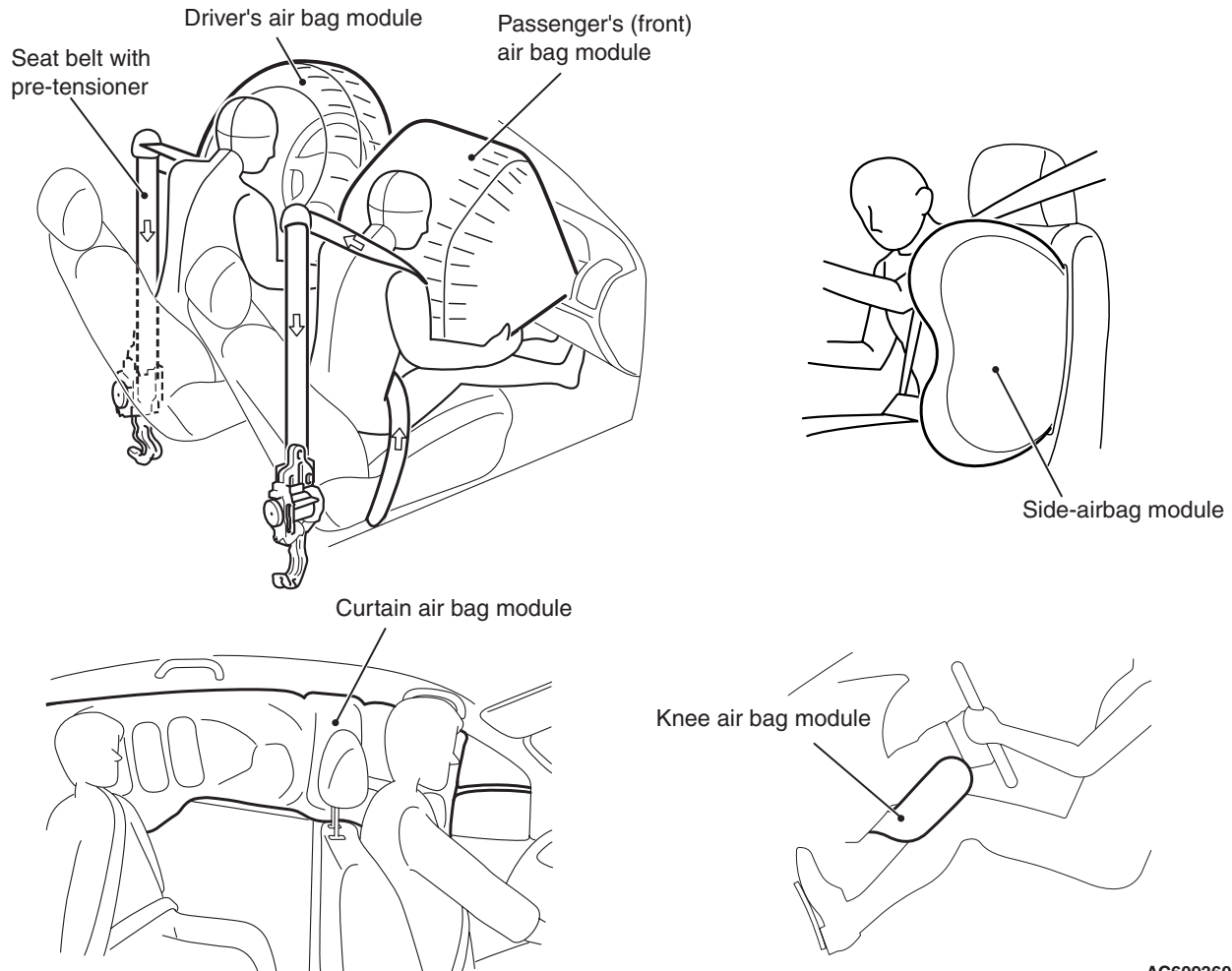

AC609360 AB

### System Component Parts

The SRS consists of driver's and passenger's (front) air bag modules, knee air bag modules, side-airbag modules, curtain air bag modules, SRS-ECU (air bag control unit), front impact sensors, side impact sensors, SRS warning light, passenger's air bag OFF indicator light, passenger's seat belt warning light, clock spring, seat belt pre-tensioner, seat belt switch, seat slide sensor, occupant classification-ECU and weight sensor. Driver's and passenger's (front) air bag modules are located in the center of the steering wheel and above the glove box. The knee air bag module has been installed to the instrument panel lower section under the steering column. Side-airbags are located inside the front seatback frame. The curtain air bag module has been installed onto the roof side section (from front pillar and back end of rear pillar). Each air bag consists of a folded air bag and an inflator unit. On all air bag modules, the inflator does not contain sodium azide. The SRS-ECU placed on the forefront of the floor monitors the system and has a front air bag safing G-sensor, front air

bag analog G-sensor and a side-airbag safing G-sensor. The front impact sensor is assembled in the front end upper bar to monitor impact in case of front impact. The side impact sensors inside the center pillars monitor the shock incurred by the sides of the vehicle. The SRS warning light on the combination meter indicates the operational status of the SRS. The clock spring is installed in the steering column. The seat belt pre-tensioner is built into the driver's and passenger's front seat belt retractor. The seat slide sensor is installed at the seat adjuster section of the driver seat in order to detect the driver seat slide position. The weight sensor is installed underneath a rail of the passenger seat to detect the load on the seat. The occupant classification-ECU mounted under the front passenger's seat determines the occupant class according to the signals from the weight sensors and sends signals to SRS-ECU. The passenger's air bag OFF indicator light is installed to the lower left of the center panel, and illuminates when the passenger's (front) air bag

is inactive. The passenger's seat belt warning light is installed to the lower right of the center panel, and illuminates when the passenger is not wearing the seat belt. The seat belt switch detects whether the seat belt is used.

The SRS-ECU will start a squib ignition current to the driver's/passenger's (front) air bag module, knee air bag module and seat belt pre-tensioner when simultaneously detecting frontal impact with the front impact sensor, front air bag safing G-sensor and

front air bag analog G-sensor. It will also supply a squib ignition current to the side-airbag module and curtain air bag module when simultaneously detecting side impact with the side impact sensor and side-airbag safing G-sensor.

CONSTRUCTION DIAGRAM

<Vehicles for USA>

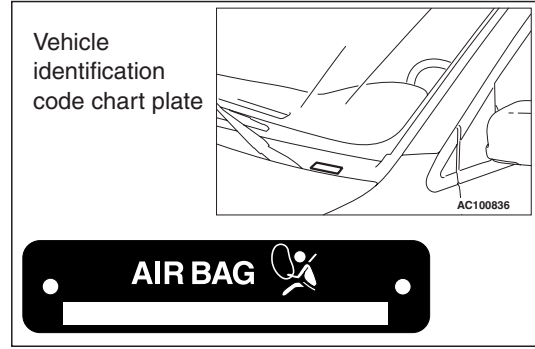
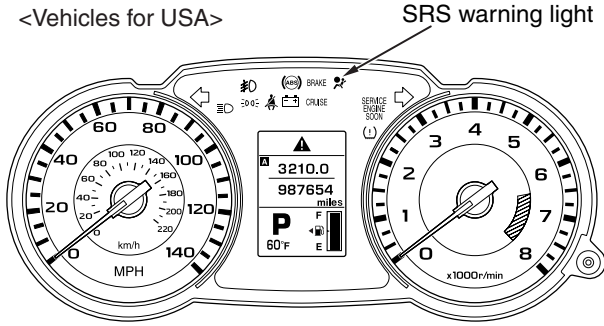

<Vehicles for CANADA>

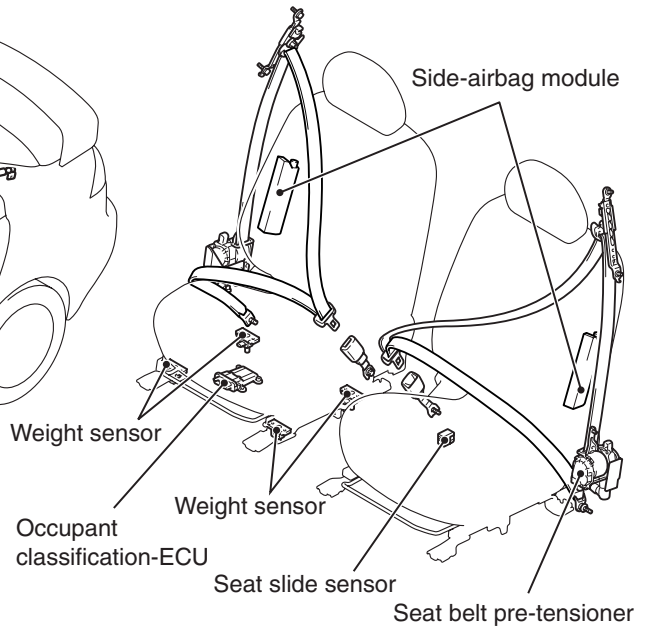
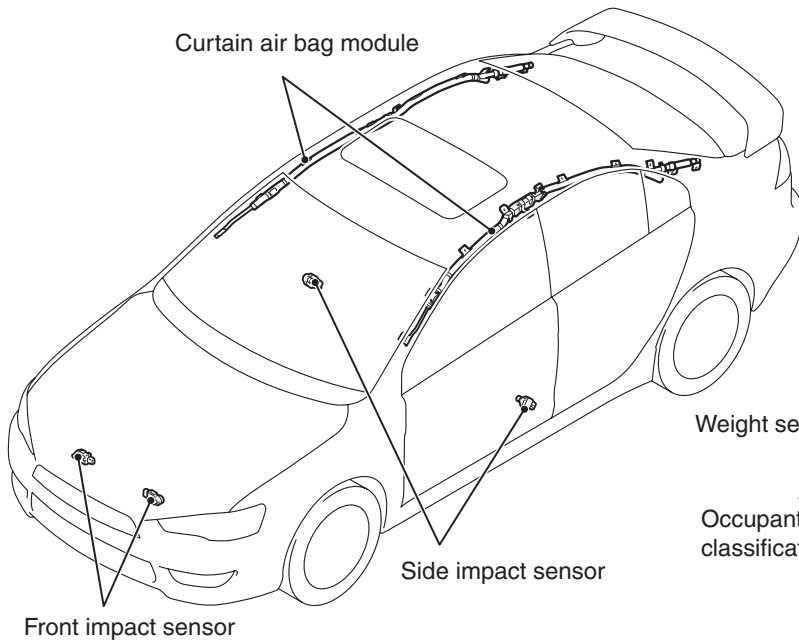
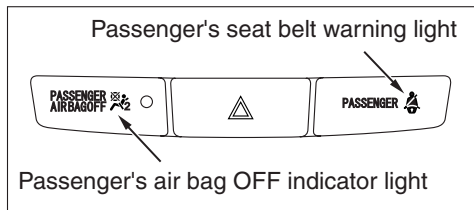
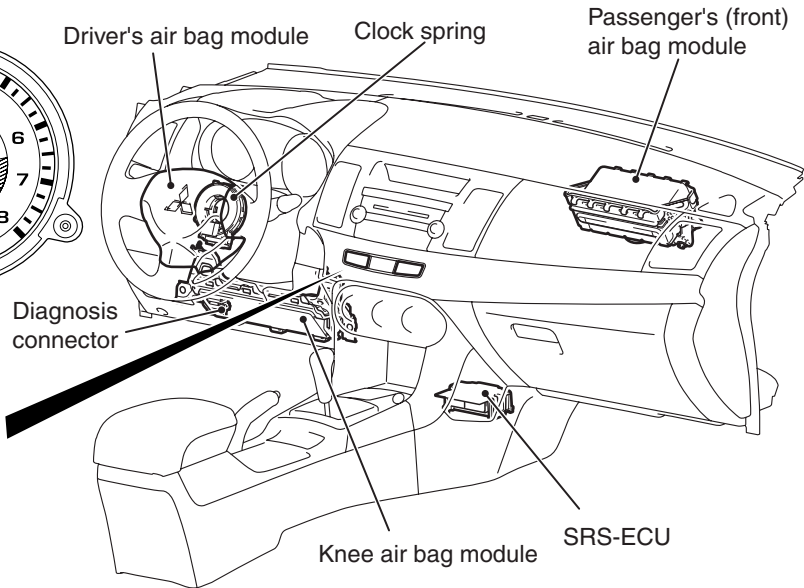
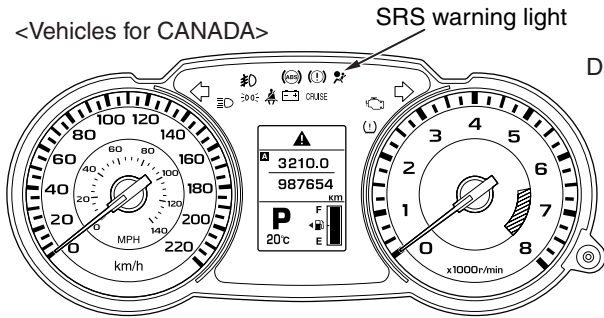

SRS SYSTEM CIRCUIT DIAGRAM

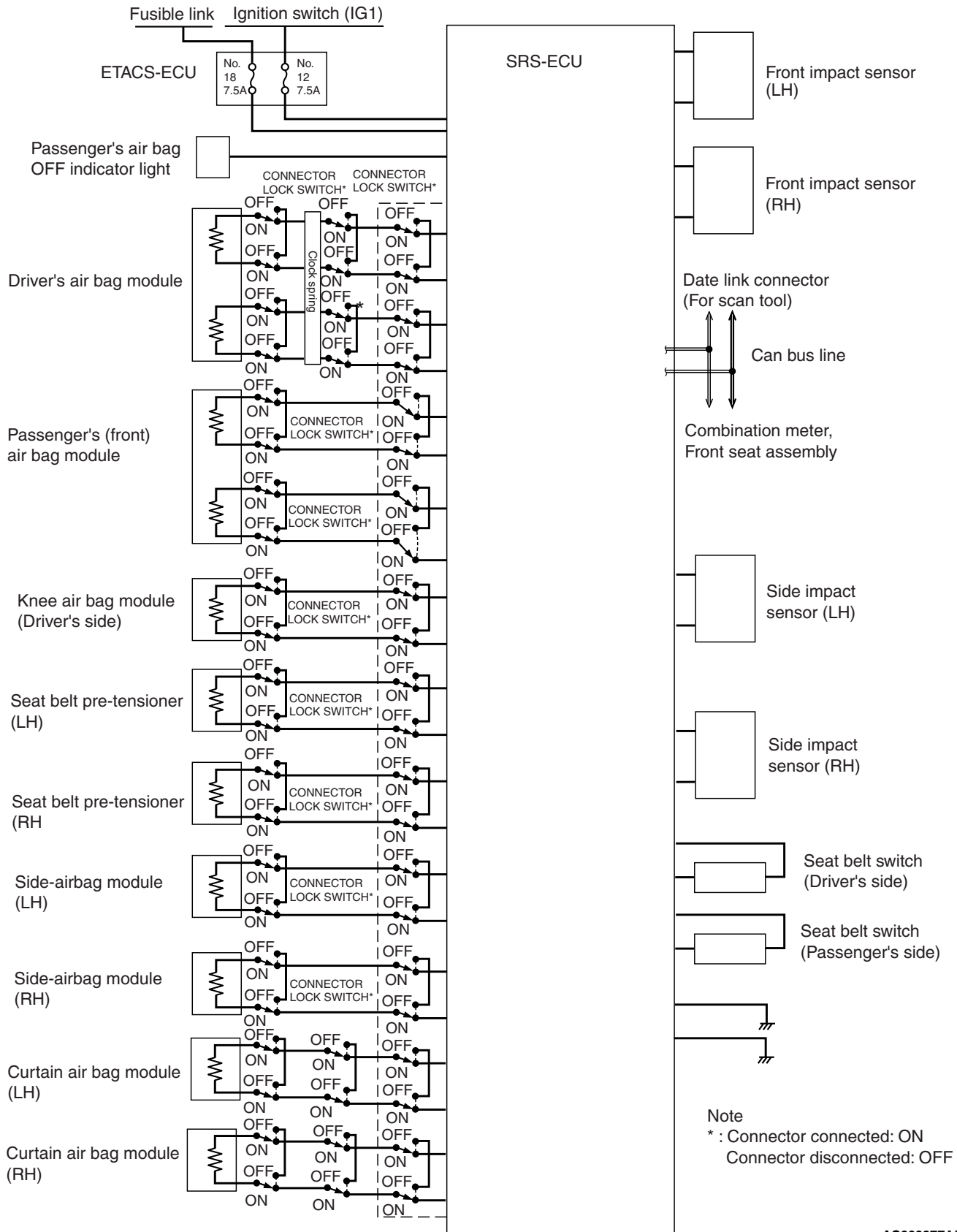

**CAUTION LABELS**

The labels indicating the precautions for handling and maintenance of SRS air bags and seat belt with pre-tensioner are adhered to the locations shown in the above figures.

**Driver's air bag module**

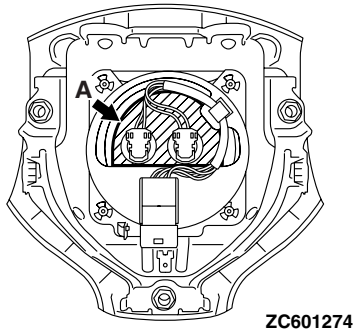

**Clock spring**

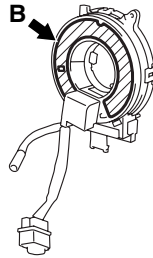

**Passenger's (front) air bag module**

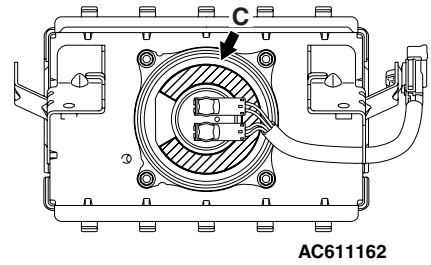

**SRS-ECU**

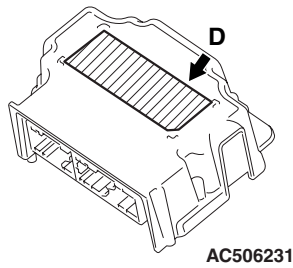

**Knee air bag module**

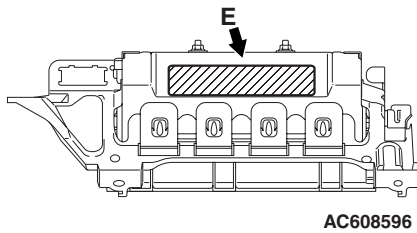

**Sunvisor**

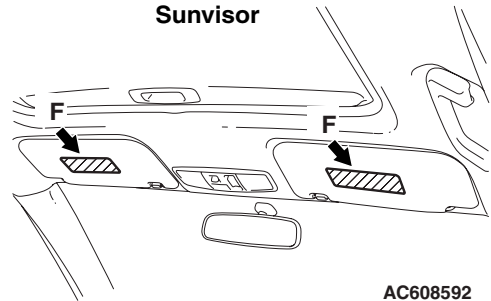

**Seat belt with pre-tensioner (right and left)**

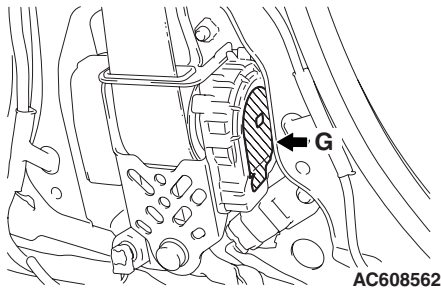

**Side-airbag module (right and left)**

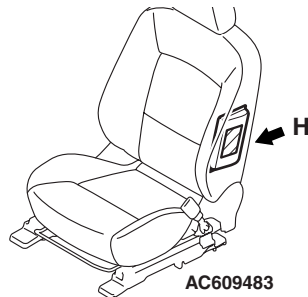

**Curtain air bag module (right and left)**

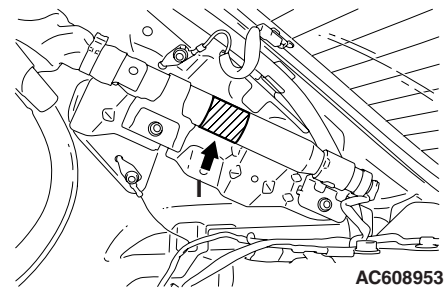

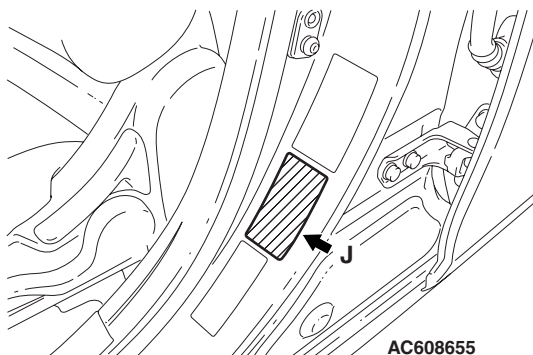

**Center pillar (right and left)**

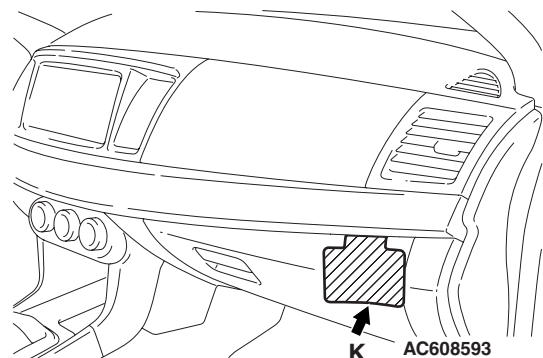

**Glove box**



<b>Label contents</b>	
A, C	<p><b>DANGER</b>  <b>FLAMMABLE EXPLOSIVE</b>  <b>DO NOT:</b>  <b>DISASSEMBLE; HEAT; INCINERATE; APPLY ELECTRICITY;</b>  <b>OR STORE AT HIGH TEMPERATURE (93° C or HIGHER).</b>  <b>REFER TO WORKSHOP MANUAL FOR DETAILS.</b></p>
B	<p><b>CAUTION: SRS CLOCK SPRING</b>  <b>PLEASE DO NOT TURN EXCEPT WHEN REQUIRED.</b>  <b>THIS IS NOT A REPAIRABLE PART. IF DEFECTIVE, PLEASE REPLACE ENTIRE UNIT</b>  <b>ACCORDING TO THE SERVICE MANUAL INSTRUCTIONS. ALIGNMENT OF</b>  <b>MODULES IS NECESSARILY WHEN THEY ARE ADJUSTED AND/OR INSTALLED</b>  <b>FOR THE ALIGNMENT PROCEDURES, FOLLOW THE SERVICE MANUAL</b>  <b>INSTRUCTIONS.</b></p>
D	<p><b>CAUTION:</b>  <b>DO NOT DISASSEMBLE OR DROP. IF DEFECTIVE, REFER TO SERVICE MANUAL.</b></p>
E	<p><b>DANGER</b>  <b>FLAMMABLE EXPLOSIVE</b>  <b>SRS AIR BAG MODULE</b></p> <ul style="list-style-type: none"> <li>• Do not disassemble or shock.</li> <li>• Do not heat or incinerate.</li> <li>• Do not contact with electricity or tester probes.</li> <li>• Do not test or diagnose.</li> <li>• Do not store in more than 200° F (93° C).</li> <li>• Store the air bag cover is top.</li> <li>• For information on handing, replacement, and disposal methods, refer to the service manual.</li> </ul>
F <EXCEPT CANADA>	<p><b>WARNING</b>  <b>EVEN WITH ADVANCED AIR BAGS</b></p> <ul style="list-style-type: none"> <li>• Children can be killed or seriously injured by the air bag</li> <li>• The back seat is the safest place for children</li> <li>• Never put a rear-facing child seat in the front</li> <li>• Always use seat belts and child restraints</li> <li>• See owner's manual for more information about air bags</li> </ul>
 AC306673	<p><b>F</b>  <b>&lt;CANADA&gt;</b></p> <p><b>WARNING</b>  <b>DEATH or SERIOUS INJURY can occur</b></p> <ul style="list-style-type: none"> <li>• Children 12 and under can be killed by the air bag.</li> <li>• The <b>BACK SEAT</b> is the <b>SAFEST</b> place for children.</li> <li>• <b>NEVER</b> put a rear-facing child seat in the front.</li> <li>• Sit as far back as possible from the air bag.</li> <li>• <b>ALWAYS</b> use <b>SEAT BELTS</b> and <b>CHILD RESTRAINTS</b>.</li> </ul>
 V0037AA	<p><b>G</b></p> <p><b>SEAT BELT PRETENSIONER CAUTION</b>  <b>THIS ASSEMBLY CONTAINS AN EXPLOSIVE INITIATOR.</b>  <b>DANGER FLAMMABLE MATERIAL</b>  <b>TO PREVENT PERSONAL INJURY</b></p> <ul style="list-style-type: none"> <li>• <b>DO NOT REMOVE. INSTALL IT INTO ANOTHER VEHICLE.</b></li> <li>• <b>SERVICE OR DISPOSE OF IT AS DIRECTED IN THE REPAIR MANUAL.</b></li> <li>• <b>DO NOT DISMANTLE INCINERATE OR BRING INTO CONTACT WITH ELECTRICITY.</b></li> </ul>



<b>Label contents</b>	
H	<p>WARNING SRS AIR BAG MODULE FLAMMABLE/EXPLOSIVE TO AVOID SERIOUS INJURY:</p> <ul style="list-style-type: none"> <li>• DO NOT REPAIR, DISASSEMBLE OR TAMPER.</li> <li>• AVOID CONTACT WITH FLAME OR ELECTRICITY.</li> <li>• DO NO DIAGNOSIS/USE NO TEST EQPT OR PROBES.</li> <li>• STORE BELOW 200° F (93° C).</li> <li>• BEFORE DOING ANY WORK INVOLVING MODULE, READ SERVICE MANUAL FOR IMPORTANT FURTHER DATA.</li> </ul>
I	<p>DANGER CONTAINS HIGH-PRESSURE GAS AND FLAMMABLE MATERIAL To avoid injury, NEVER; [Repair, Disassembly, Incinerate, Bring into contact with electricity, Install onto another vehicle or Store where the temperature is above 93° C (200° F)] -See Repair Manual for details.-</p>
J	<p>SRS SIDE AIRBAG WARNING TO AVOID SERIOUS INJURY OR DEATH:</p> <ul style="list-style-type: none"> <li>• Do not lean against the door.</li> <li>• Do not use seat covers.</li> </ul> <p>See owner's manual for more information</p>
K <EXCEPT CANADA>	<p>This Vehicle is Equipped with Advanced Air Bags Even with Advanced Air Bags Children can be killed or seriously injured by the air bag. The back seat is the safest place for children. Never put a rear-facing child seat in the front. Always use seat belts and child restraints. See owner's manual for more information about air bags. Not to be removed except by owner.</p>
K <CANADA>	<p>WARNING MISE EN GARDE Children Can Be KILLED or INJURED by Passenger Air Bag The back seat is the safest place for children 12 and under. Make sure all children use seat belts or child seats. Not to be removed except by owner.</p>

## SYSTEM OPERATION

## ADVANCED AIR BAG AND SEAT BELT WITH PRE-TENSIONER

M2521000700349

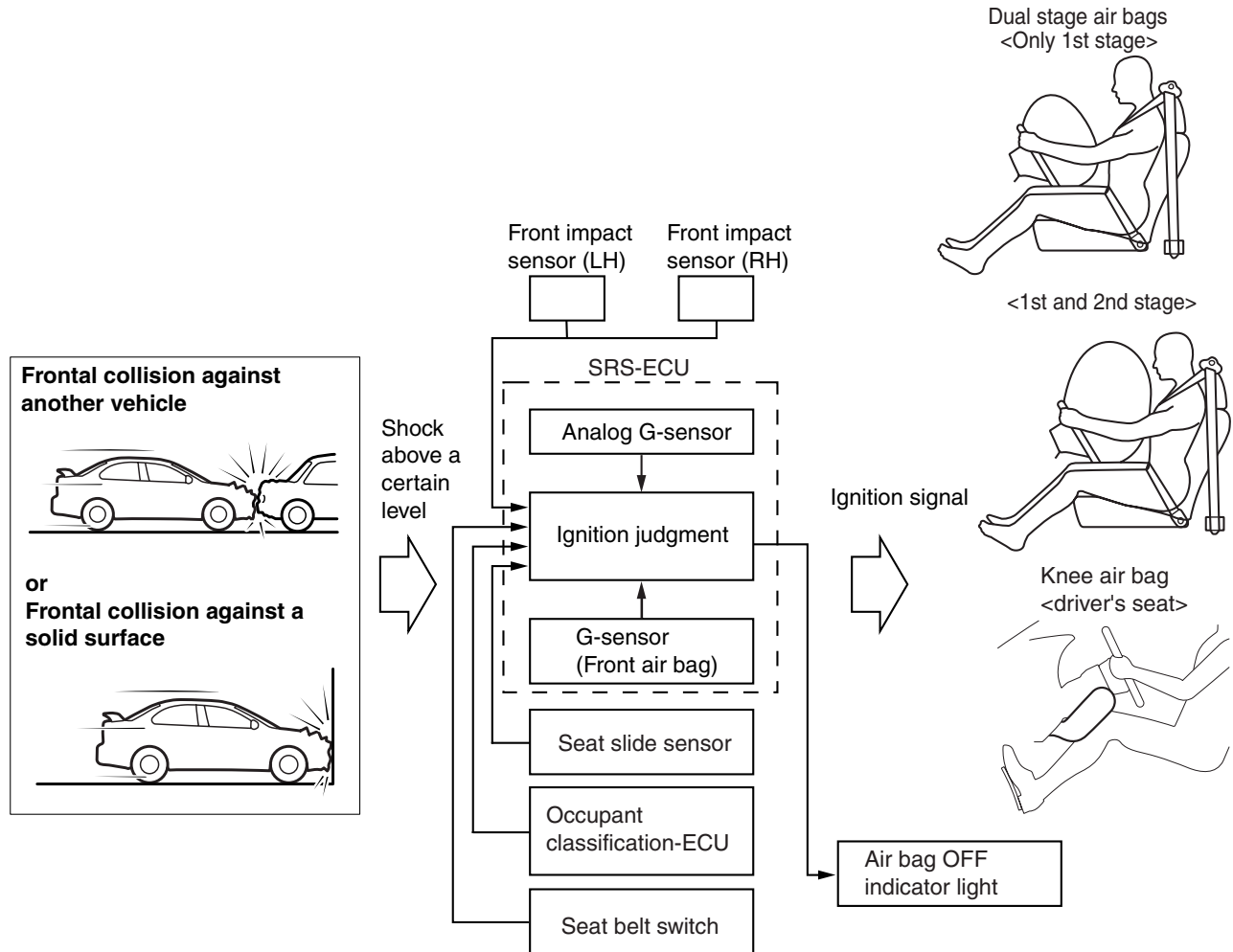

AC609449AB

- In case of a frontal collision, when the front impact sensor inside the engine room and the G-sensor inside SRS-ECU simultaneously detect an impact that exceeds a certain threshold (turned ON), SRS-ECU energizes the driver's and passenger's (front) air bag modules (squibs), knee air bag module (squib) and driver's and passenger's seat belt pre-tensioners (squibs), thus deploying the air bags and triggering the seat belt pre-tensioners. Also, the advanced air bag has been adopted to optimize the air bag deployment control by adjusting the inflation pressure.
- The seat slide sensor to detect the driver's seat position judges the deployment in two stages, and deploys the driver's air bag.
- The occupant classification-ECU has been added to recognize the passenger's seat occupant. The occupant classification-ECU identifies the occupant class based on the signals from weight sensors, and sends the signal to SRS-ECU.

**SIDE AND CURTAIN AIR BAGS**

M252100800250

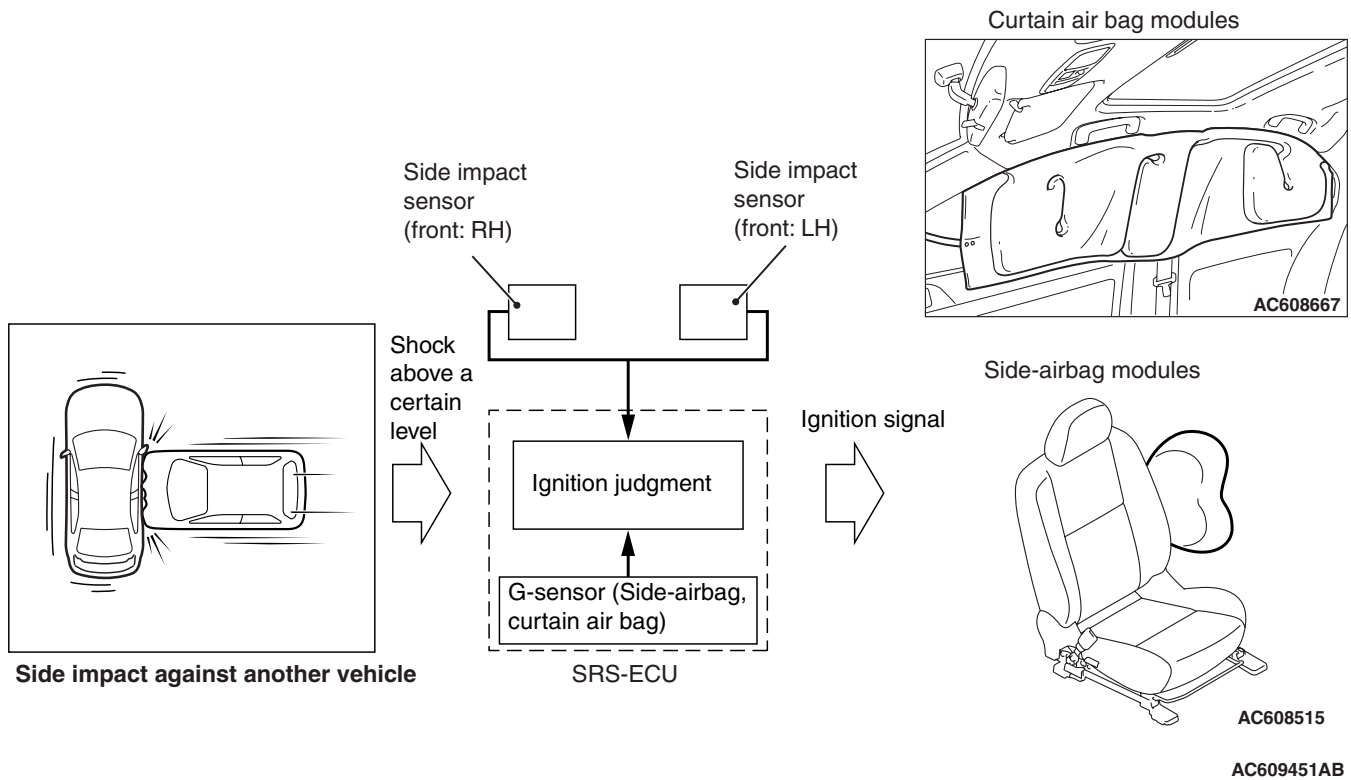

SRS-ECU uses data of the side impact sensor and G-sensor (in SRS-ECU) to calculate collision severity, during side collision. SRS-ECU judges necessity of side-airbag and curtain air bag based on the calculated collision severity.

**SYSTEM CONSTRUCTION**

**DRIVER'S SIDE AIR BAG MODULE**

M2521002000432

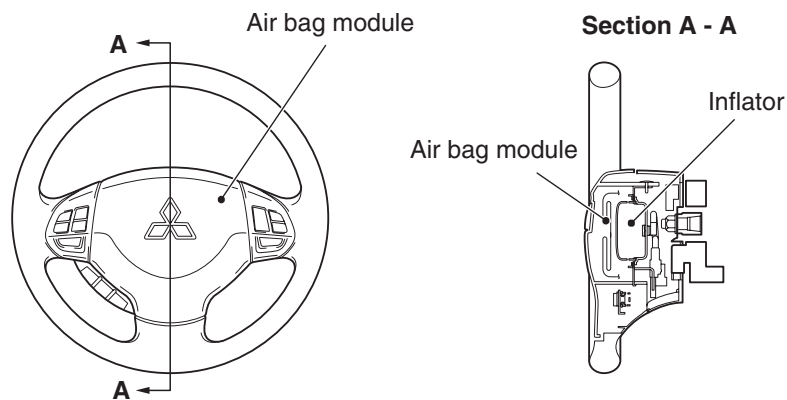

AC607285 AC

The driver's air bag module incorporates a three-spoke steering wheel. The driver's air bag module is an assembly part consisting of an air bag, inflator, and their fasteners. The air bag is made from nylon and inflates by gas from the inflator. As a driver

is being pressed to the air bag, it deflates discharging gas from two vents at the rear of the air bag to reduce the shock from the impact. The driver's air bag deploys by changing its inflation pressure in two steps. The inflator has two squib connectors to deploy the air bag in two steps. The inflator does not contain sodium azide.

## CLOCK SPRING

M2521001100072

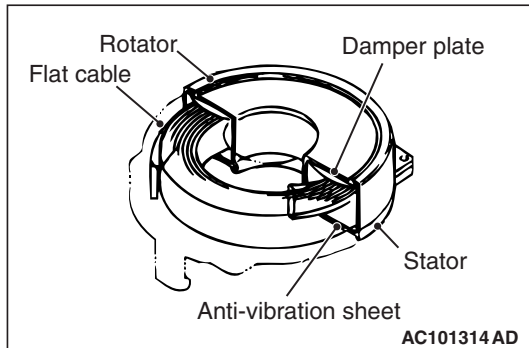

The clock spring consists of a flat cable, rotator, stator, etc. The flat cable is loosely wound in the case in coil-form. One end is attached to the rotator and the other end is attached to the stator. By turning the steering wheel, the clock spring rotator turns along with the steering shaft. The flat cable is wound or unwound by the rotator according to how the steering wheel turns. It must be in the neutral position when assembling the clock spring.

**NOTE:** For the clock spring centering procedures, refer to the SERVICE MANUAL.

## PASSENGER'S (FRONT) AIR BAG MODULE

M2521002100116

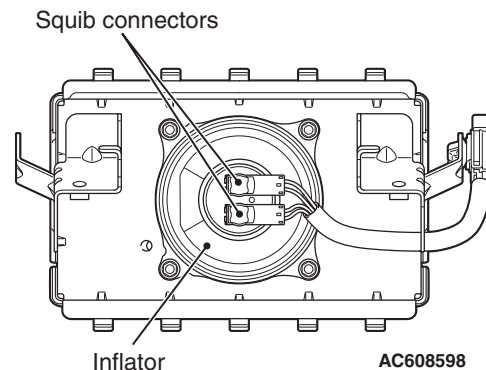
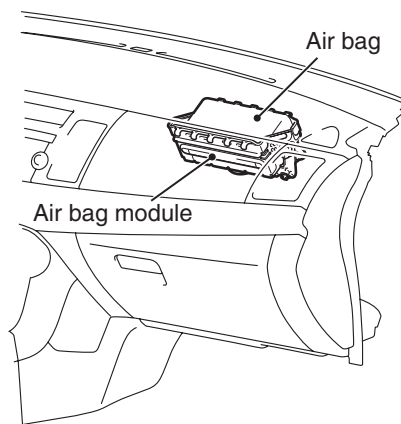

The passenger's (front) air bag module consists of an air bag, and their fasteners.

The air bag is made from nylon and inflates by the gas from the inflator. As a passenger is being pressed to the air bag, it deflates, discharging gas from two vents at the side of the air bag to reduce the shock from the impact.

The front passenger's air bag deploys by changing its inflation pressure in two steps.

The inflator has two squib connector to deploy the air bag in two steps.

The front passenger air bag does not deploy at the front passenger seat is not occupied and when the occupant classification sensor in the front passenger seat senses a weight on the seat of less than 66 pounds (30 kg).

An inflator that does not contain sodium azide is used.

AC609452AB

**KNEE AIR BAG MODULE**

M2521002600014

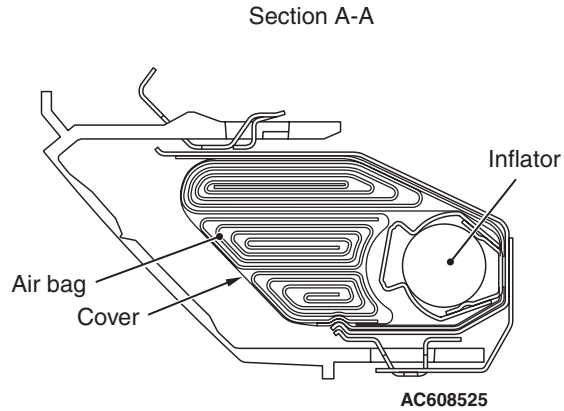
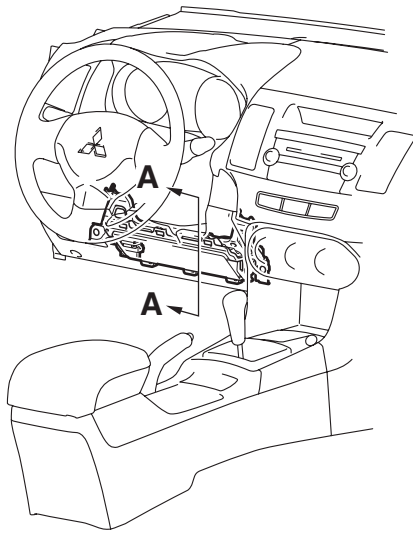

AC609476AB

The knee air bag consists of the air bag, inflator, and fixing gear relating to those parts, and is installed onto the instrument panel lower under the steering column.

At the frontal collision, the knee air bag deploys by the gas generated from the inflator to protect passenger's feet (knee and leg). Like the air bags for frontal collision, the side air bags are made of nylon whose inside is rubber-coated, and is folded up and housed in a cover. Gas exhaust openings are provided at the sewed sections of the air bags to reduce the impacts on the passenger's feet at deployment. An inflator that does not contain sodium azide is used.

**SIDE-AIRBAG MODULE**

M2521004000290



AC609459AB

The side-airbag module consists of an air bag, air bag cover, inflator and their fasteners. The modules are installed in the outer side supports of the driver's and front passenger's seatbacks. The side-airbags help protect the occupants regardless of the seat position and seatback angle.

The side-airbag made of nylon fabric. The air bags are compactly folded and stored under the cover. On the side of the air bag, there are holes through which gas is partially released to alleviate shock to the occupant when the air bag is deployed. An inflator that does not contain sodium azide is used.

## CURTAIN AIR BAG MODULE

M2521000500226

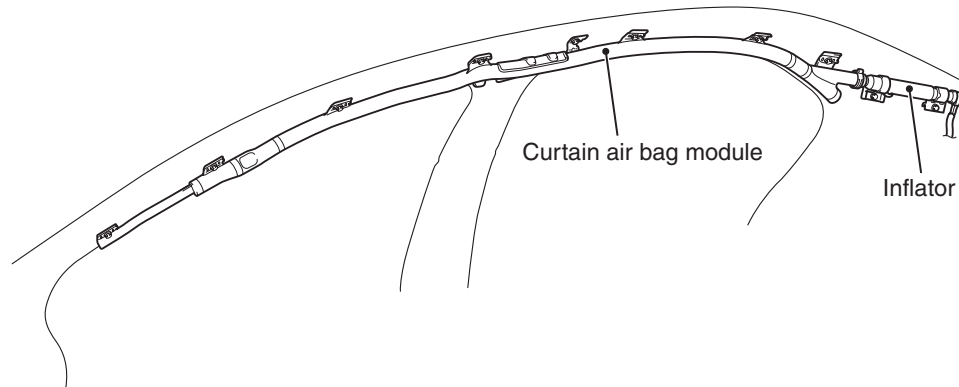

AC608585 AB

The curtain air bag module consists of an air bag, an inflator, and the fixing gear relating to those parts, and is installed in the roof side sections (from the driver's and the passenger's front pillars to the rear pillars).

The air bag is made from nylon with the inside coated with silicon, and housed in the roof side sections, folded up compactly.

The inflator is of a cold gas type filled with high-pressure gas (major component: Argon). When current passes through the squib to ignite the igniter powder, the burst disk bursts, emitting the gas into the air bag.

## FRONT IMPACT SENSOR

M2521005000442

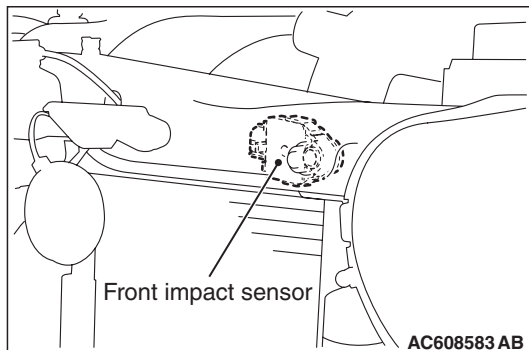

- The front impact sensor is installed on the front end upper in the engine room, and the analogue G-sensor is housed in the front impact sensor.
- The front impact sensor transmits the coded acceleration data to SRS-ECU. Based on the data, SRS-ECU determines the deployment stage of the front air bag, then energizes appropriate squib.
- SRS-ECU performs the diagnostics of the front impact sensor internal components. If a malfunction occurs, it sets the diagnostic trouble code.

## SIDE IMPACT SENSOR

M2521006000371

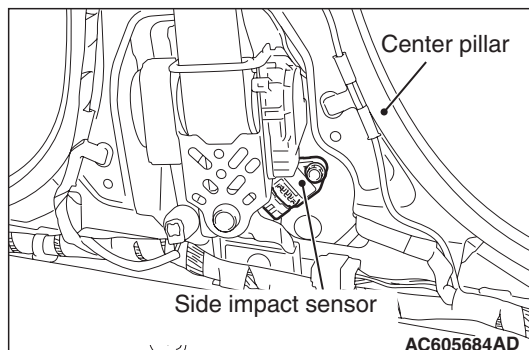

- The side impact sensors are installed to the lower part of the center pillars on both sides and to the quarter panels on both sides, and the analogue G-sensor is housed in the side impact sensor.
- The side impact sensor transmits the coded acceleration data to SRS-ECU. Based on the data, SRS-ECU determines the deployment of the side-airbags and curtain air bags, then energizes appropriate squib(s).
- SRS-ECU performs the diagnostics of the side impact sensor internal components. If a malfunction occurs, it sets the diagnostic trouble code.

**SEAT SLIDE SENSOR**

M2521001400103

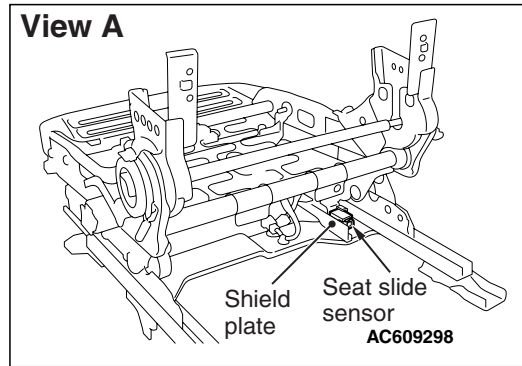
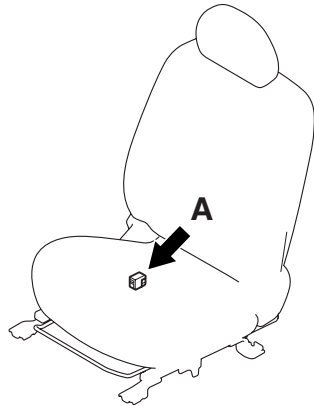

AC609466 AB

- The seat slide sensor is attached to the slide adjuster on the driver's seat side, and the seat is moved forward/backward by seat sliding. When the seat is slid forward, the shield plate covers the sensor, and the sensor determines that the seat slide position is set forward.
- The seat slide sensor outputs the current by switching high output current and low output current from the seat slide position as shown in the figure. Based on the output current, SRS-ECU determines the deployment stage of the front air bag, and then energizes the squib.

Shield plate position	Current value	Deployment stage
When the shield plate is in the detection range of the seat slide sensor	Low output current	Only 1 stage
When the shield plate is not in the detection range of the seat slide sensor	High output current	1st and 2nd stage

**OCCUPANT CLASSIFICATION-ECU AND WEIGHT SENSOR**

M2521001300032

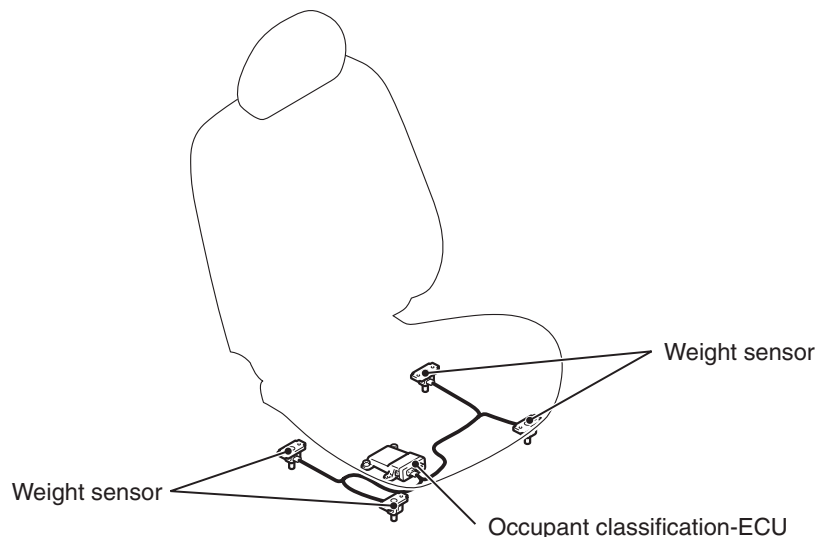

AC608516 AB

The weight sensors are attached to the seat rails and provide SRS-ECU with information on the weight applied to the front passenger seat.

The occupant classification-ECU identifies the occupant class based on the signals from weight sensors, and sends the signal to SRS-ECU. When the occupant is determined to be less than 66 lbs (30 kg), the passenger's (front) air bag is not deployed.

## DIAGNOSTIC TROUBLE CODE OUTPUT

The occupant classification-ECU diagnoses the following items and stores a diagnostic trouble code in the non-volatile memory (EEPROM\*<sup>1</sup>) when a problem is detected. Therefore, the memory is not deleted after a battery terminal is disconnected, (The diagnostic trouble code memory can be deleted by the scan tool.)

Diagnostic trouble Code No.	Inspection item
B1B78	Passenger seat weight sensor (front) (LH) performance
B1B79	Passenger seat weight sensor (ground side) short-circuited (front) (LH)
B1B7A	Passenger seat weight sensor (power supply side) short-circuited (front) (LH)
B1B7D	Passenger seat weight sensor (front) (RH) performance
B1B7E	Passenger seat weight sensor (ground side) short-circuited (front) (RH)
B1B7F	Passenger seat weight sensor (power supply side) short-circuited (front) (RH)
B1B82	Passenger seat weight sensor (rear) (LH) performance
B1B83	Passenger seat weight sensor (ground side) short-circuited (rear) (LH)
B1B84	Passenger seat weight sensor (power supply side) short-circuited (rear) (LH)
B1B87	Passenger seat weight sensor (rear) (RH) performance
B1B88	Passenger seat weight sensor (ground side) short-circuited (rear) (RH)
B1B89	Passenger seat weight sensor (power supply side) short-circuited (rear) (RH)
B1B8C	Seat slide sensor circuit performance
B1B8D	Seat slide sensor open circuit
B1B8E	Seat slide sensor short circuit
B1B91	Driver seat slide sensor configuration mismatch
B1BA7	Occupant classification system verification required
B1BA8	Occupant classification-ECU out of calibration/Not calibrated
B1BBA	Passenger seat weight sensor supply circuit
B1BBC	Occupant classification system negative system weight
B1BBD	Occupant classification-ECU current configuration table unprogrammed
B1C23	Passenger seat weight sensor (front) (LH) configuration mismatch
B1C24	Passenger seat weight sensor (front) (RH) configuration mismatch
B1C25	Passenger seat weight sensor (rear) (LH) configuration mismatch
B1C26	Passenger seat weight sensor (rear) (RH) configuration mismatch
B1CB2	Occupant classification-ECU parameter table incompatible
B210D	Battery voltage low
B210E	Battery voltage high



<b>Diagnostic trouble Code No.</b>	<b>Inspection item</b>
B2206	Chassis number does not match
B2212	Occupant classification-ECU internal
B2250	Occupant classification-ECU not programmed/Flash required
B2262	Occupant classification-ECU electrostatic discharge event detected
U0020	CAN-B Bus off performance
U0021	CAN-B Bus(+) circuit open
U0022	CAN-B Bus(+) shorted to circuit ground
U0023	CAN-B Bus(+) shorted to circuit power supply
U0024	CAN-B Bus(-) circuit open
U0025	CAN-B Bus(-) shorted to circuit ground
U0026	CAN-B Bus(-) shorted to circuit power supply
U0141	ETACS CAN timeout
U0151	SRS-ECU CAN timeout
U0155	Combination meter CAN timeout
U0164	A/C-ECU CAN timeout
U0168	KOS-ECU or WCM CAN timeout
U0184	Audio CAN timeout
U0195	Satellite radio tuner CAN timeout
U0197	Hands free module CAN timeout
U0245	Audio visual navigation unit CAN timeout
U1419	The signal from a weight sensor (front) (LH) is unusual
U141A	The signal from a weight sensor (front) (RH) is unusual
U141B	The signal from a weight sensor (rear) (LH) is unusual
U141C	The signal from a weight sensor (rear) (RH) is unusual
U1423	The signal from a weight sensor is unusual

## DATA LIST OUTPUT

The following items can be read by the scan tool from the occupant classification-ECU input data.

<b>Item No.</b>	<b>Display on M.U.T.-III</b>	<b>Check conditions</b>	<b>Normal conditions</b>
01	Passenger weight	Apply a load to the passenger seat.	-2,048 Kg (-4,515 lb) to 2,048 Kg (4,515 lb)
02	Dr seat position sensor current	Slide the seat the back-end to the front-position.	0 to 4,095.93 mA
03	Dr seat position sensor voltage	Slide the seat the back-end to the front-position.	0 to 5,000 mV
07	Dr seat position sensor status	Slide the seat the back-end to the front-position.	Not in Frontal Zone/In Frontal Zone/Undetermined
08	occupant classification status	Apply a load to the passenger seat.	Empty/PFIS/Child/More 5th%/Undermined
10	Battery voltage	Always	0 to 30 V

Item No.	Display on M.U.T.-III	Check conditions	Normal conditions
21	Pa seat weight sensor 1 RR	Apply a load to the passenger seat.	-2,048 Kg (-4,515 lb) to 2,048 Kg (4,515 lb)
22	Pa seat weight sensor 1 RR volt	Apply a load to the passenger seat.	0 to 5,000 mV
23	Pa seat weight sensor 2 RF	Apply a load to the passenger seat.	-2,048 Kg (-4,515 lb) to 2,048 Kg (4515 lb)
24	Pa seat weight sensor 2 RF volt	Apply a load to the passenger seat.	0 to 5,000 mV
25	Pa seat weight sensor 3 LF	Apply a load to the passenger seat.	-2,048 Kg (-4,515 lb) to 2,048 Kg (4,515 lb)
26	Pa seat weight sensor 3 LF volt	Apply a load to the passenger seat.	0 to 5,000 mV
27	Pa seat weight sensor 4 LR	Apply a load to the passenger seat.	-2,048 Kg (-4,515 lb) to 2,048 Kg (4,515 lb)
28	Pa seat weight sensor 4 LR volt	Apply a load to the passenger seat.	0 to 5,000 mV
30	VIN Information	Always	-

**ACCURACY CHECK OCCUPANT classification sensor**

The scan tool can be used to perform the next function.

- seat weight sensor Accuracy Check
- Zero-calibration

**SEAT BELT WITH PRE-TENSIONER**

M2521008000429

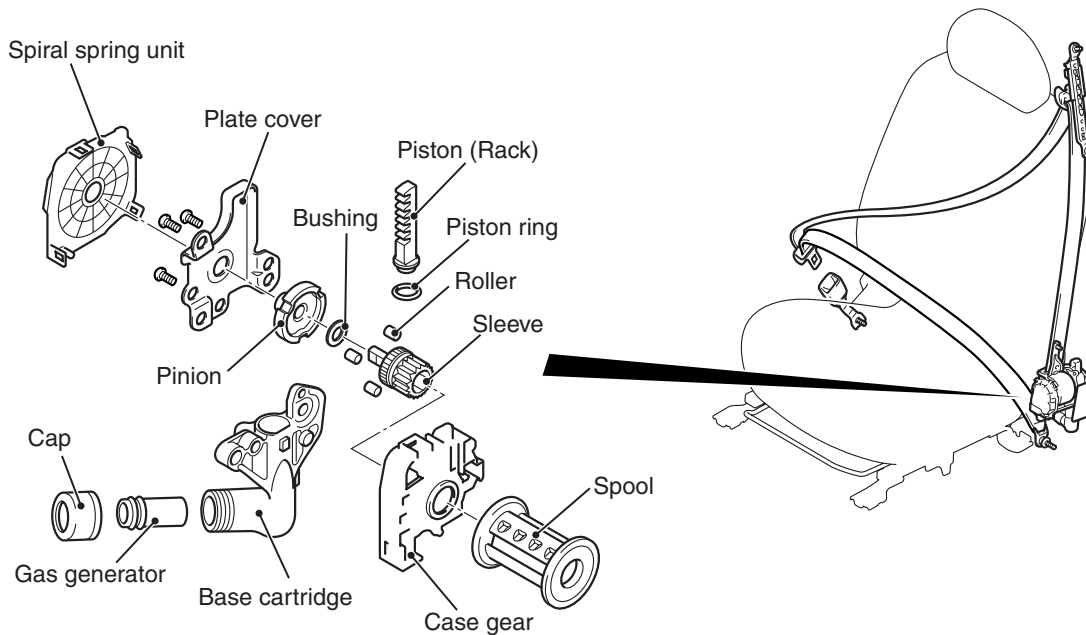

AC609471AB

The seatbelt pretensioner automatically winds the seatbelt at the frontal collision to restrain the forward travel of the passenger. The seatbelt pretensioner operates in ahead of the SRS airbag deployment to

restrain the forward travel of the passenger at the frontal collision, for achieving the effective SRS airbag.

### Seatbelt pretensioner operation

1. When the pretensioner is inactivated, the clearance between the roller and the sleeve is secured, and thus the sleeve rotates freely. The spool which winds the seatbelt rotates together as with the sleeve.

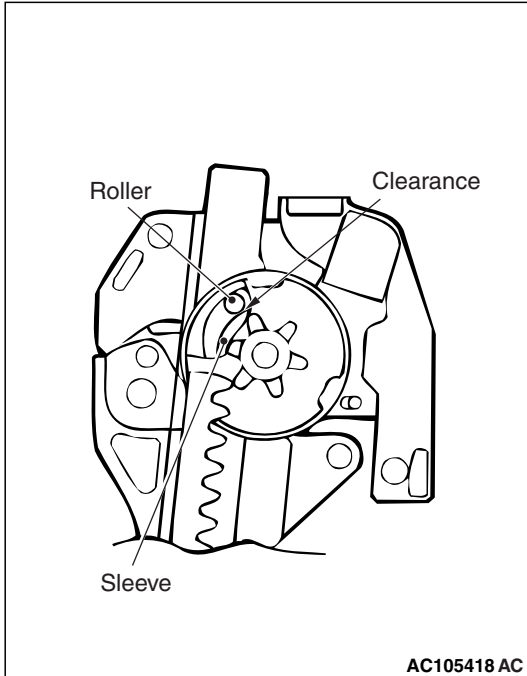

2. At the frontal collision, SRS-ECU which has detected the impact exceeding the threshold from the front impact sensors is energized to ignite the gas generator. Then the gas is generated, and the gas pressure moves up the piston.
3. When the piston moves up, the rack gear of the piston is engaged with the pinion gear of the pinion to rotate the pinion. When the pinion rotates, the pinion is tilted to move the roller to the center, and the pinion, sleeve, and spool are incorporated.

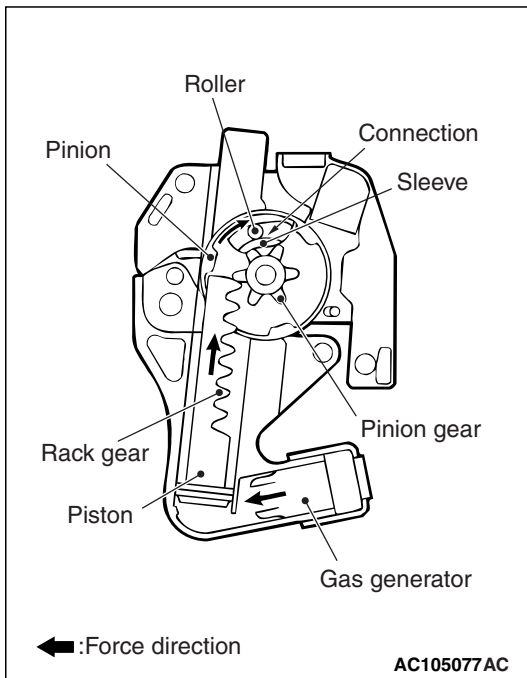

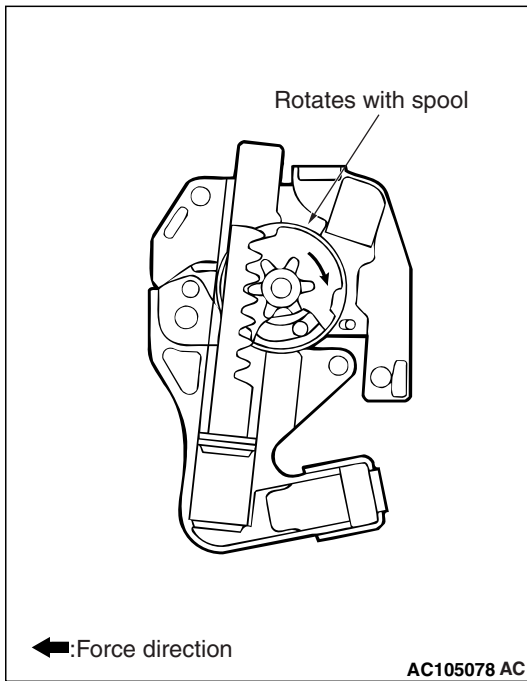

- The gas pressure moves up the piston farther, and the pinion rotates the spool to wind the belt.

## PASSENGER SEAT BELT WARNING LIGHT

M2521001500036

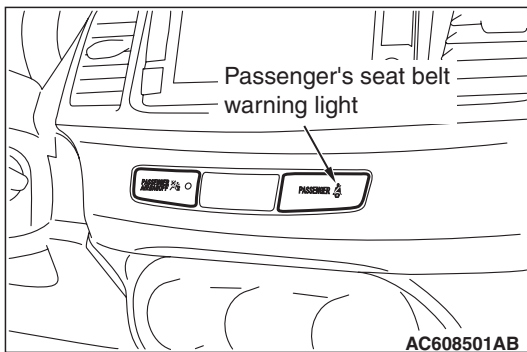

The passenger's seat belt warning light turns ON when the passenger's seat occupant is determined to be 66 lbs (30 kg) or more by the occupant classification-ECU and his seat belt is not fastened.

## PASSENGER'S AIR BAG OFF INDICATOR LIGHT

M2521001600055

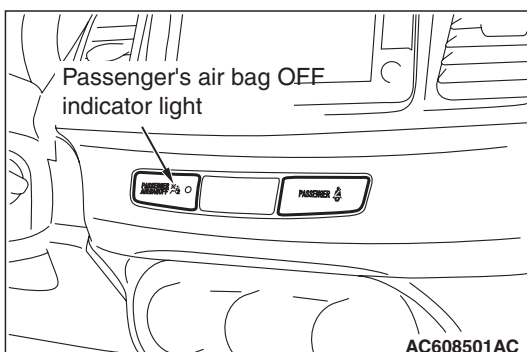

The indicator normally comes on when the ignition switch is turned to the "ON" position and goes off a few seconds later. In the following situations, the indicator will stay on to show that the passenger's (front) air bag is not operational.

- The occupant is determined to be less than 66 lbs (30 kg) by the occupant classification-ECU.
- The front passenger's seat is not occupied.

The indicator goes off when the occupant is determined to be 66 lbs (30 kg) or more by the occupant classification-ECU, indicating that the passenger's (front) air bag is operational.

## SRS-ECU

The SRS-ECU incorporates a front analog G-sensor and front safing G-sensor for frontal collisions and a side-airbag safing G-sensor for side collisions. SRS-ECU enters an ignite signal to the driver's and passenger's (front) air bag modules if the front impact sensor in the engine compartment, the front analog G-sensor and front safing G-sensor in the SRS-ECU simultaneously detect gravitational impact upon front impact. Further, SRS-ECU starts an ignite signal for the side and curtain air bag module upon sideways gravitational impact that is simultaneously detected by the analog G-sensor of the side impact sensor and the side-airbag safing G-sensor inside the SRS-ECU.

The SRS-ECU is provided with the following capabilities:

- Backup power supply in case of power failure in collisions
- Boosting function in case of battery voltage drop
- Self-diagnosis function to avoid system's operation errors and improve its reliability

## DIAGNOSTIC FUNCTION

The SRS-ECU has the following functions to make system checking using the scan tool easy.

- Diagnostic trouble code output
- Service data output
- Actuator test

## DIAGNOSTIC TROUBLE CODE OUTPUT

The SRS-ECU diagnoses the following items and stores a diagnostic trouble code in the non-volatile memory (EEPROM\*1) when a problem is detected. Therefore, the memory is not deleted after a battery terminal is disconnected, (The diagnostic trouble code memory can be deleted by the scan tool.)

<b>Diagnostic trouble Code No.</b>	<b>Inspection item</b>
B1206	Passenger's air bag OFF indicator light (open circuit)
B1207	Passenger's air bag OFF indicator light (short circuit between circuit terminal)
B1B00	Driver's air bag module (1st squib) system (shorted to squib circuit ground)
B1B01	Driver's air bag module (1st squib) system (shorted to squib circuit power supply)
B1B02	Driver's air bag module (1st squib) system (squib circuit open)
B1B03	Driver's air bag module (1st squib) system (short circuit between squib circuit terminals)
B1B04	Driver's air bag module (2nd squib) system (shorted to squib circuit ground)
B1B05	Driver's air bag module (2nd squib) system (shorted to squib circuit power supply)
B1B06	Driver's air bag module (2nd squib) system (squib circuit open)
B1B07	Driver's air bag module (2nd squib) system (short circuit between squib circuit terminals)
B1B08	Passenger's (front) air bag module (1st squib) system (shorted to squib circuit ground)
B1B09	Passenger's (front) air bag module (1st squib) system (shorted to squib circuit power supply)
B1B0A	Passenger's (front) air bag module (1st squib) system (squib circuit open)
B1B0B	Passenger's (front) air bag module (1st squib) system (short circuit between squib circuit terminals)
B1B0C	Passenger's (front) air bag module (2nd squib) system (shorted to squib circuit ground)
B1B0D	Passenger's (front) air bag module (2nd squib) system (shorted to squib circuit power supply)

Diagnostic trouble Code No.	Inspection item
B1B0E	Passenger's (front) air bag module (2nd squib) system (squib circuit open)
B1B0F	Passenger's (front) air bag module (2nd squib) system (short circuit between squib circuit terminals)
B1B10	Driver's knee air bag module (squib) system (shorted to squib circuit ground)
B1B11	Driver's knee air bag module (squib) system (shorted to squib circuit power supply)
B1B12	Driver's knee air bag module (squib) system (squib circuit open)
B1B13	Driver's knee air bag module (squib) system (short circuit between squib circuit terminals)
B1B18	Curtain air bag module (LH) (squib) system (shorted to squib circuit ground)
B1B19	Curtain air bag module (LH) (squib) system (shorted to squib circuit power supply)
B1B1A	Curtain air bag module (LH) (squib) system (squib circuit open)
B1B1B	Curtain air bag module (LH) (squib) system (short circuit between squib circuit terminals)
B1B20	Curtain air bag module (RH) (squib) system (shorted to squib circuit ground)
B1B21	Curtain air bag module (RH) (squib) system (shorted to squib circuit power supply)
B1B22	Curtain air bag module (RH) (squib) system (squib circuit open)
B1B23	Curtain air bag module (RH) (squib) system (short circuit between squib circuit terminals)
B1B50	seat belt switch (LH) circuit (ground side) shorted
B1B51	seat belt switch (LH) circuit (power supply side) shorted
B1B52	seat belt switch (LH) circuit open
B1B54	seat belt switch (RH) circuit (ground side) shorted
B1B55	seat belt switch (RH) circuit (power supply side) shorted
B1B56	seat belt switch (RH) circuit open
B1B70	Malfunction of G-sensor inside front impact sensor (LH)
B1B71	Malfunction of G-sensor inside front impact sensor (RH)
B1B72	Malfunction of G-sensor inside side impact sensor (LH)
B1B75	Malfunction of G-sensor inside side impact sensor (RH)
B1BA3	Driver's seat slide sensor malfunction (occupant classification-ECU)
B1BA5	SRS-ECU squib count mismatch
B1BAA	Occupant classification-ECU configuration mismatch
B1BC7	SRS-ECU (record data full) system
B1C27	Side-airbag module (LH) (squib) system (shorted to squib circuit ground)
B1C28	Side-airbag module (LH) (squib) system (shorted to squib circuit power supply)
B1C29	Side-airbag module (LH) (squib) system (squib circuit open)
B1C2A	Side-airbag module (LH) (squib) system (short circuit between squib circuit terminals)
B1C2B	Side-airbag module (RH) (squib) system (shorted to squib circuit ground)
B1C2C	Side-airbag module (RH) (squib) system (shorted to squib circuit power supply)
B1C2D	Side-airbag module (RH) (squib) system (squib circuit open)

<b>Diagnostic trouble Code No.</b>	<b>Inspection item</b>
B1C2E	Side-airbag module (RH) (squib) system (short circuit between squib circuit terminals)
B1C38	Driver's pre-tensioner (squib) system (shorted to squib circuit ground)
B1C39	Driver's pre-tensioner (squib) system (shorted to squib circuit power supply)
B1C3A	Driver's pre-tensioner (squib) system (squib circuit open)
B1C3B	Driver's pre-tensioner (squib) system (short circuit between squib circuit terminals)
B1C47	Front passenger's pre-tensioner (squib) system (shorted to squib circuit ground)
B1C48	Front passenger's pre-tensioner (squib) system (shorted to squib circuit power supply)
B1C49	Front passenger's pre-tensioner (squib) system (squib circuit open)
B1C4A	Front passenger's pre-tensioner (squib) system (short circuit between squib circuit terminals)
B210D	Battery abnormal low voltage
B212C	Open circuit to IG1 power supply (fuse No. 12 circuit)
B212D	Open circuit to IG1 power supply (fuse No. 18 circuit)
B2207	Occupant restraint controller internal 1
B2208	Occupant restraint controller internal 2
B2209	Occupant restraint controller internal 3
B220A	Occupant restraint controller internal 4
B220B	Occupant restraint controller firing stored energy
B220C	Occupant restraint controller accelerometer 1
B220D	Occupant restraint controller accelerometer 2
B223D	OCM (Occupant Classification-ECU) DTC present
U0019	Bus off (CAN-B)
U0141	ETACS CAN timeout
U0154	Occupant classification-ECU CAN timeout
U0155	Combination meter CAN timeout
U0164	A/C -ECU CAN timeout
U0168	KOS -ECU or WCM CAN timeout
U0170	Front impact sensor (LH) communication error
U0171	Front impact sensor (RH) communication error
U0172	Side impact sensor (LH) communication error
U0175	Side impact sensor (RH) communication error
U0184	Audio CAN timeout
U0195	Satellite radio tuner CAN timeout
U0197	Hands free Module CAN timeout
U1414	Defective Coding Data
U1415	Coding not completed/Data fail

**DATA LIST OUTPUT**

The following items can be read by the scan tool from the SRS-ECU input data.

Item No.	Display on M.U.T.-III	Check conditions	Normal conditions
01	SRS warning light "ON" request	<ul style="list-style-type: none"> <li>Ignition switch: ON</li> <li>After warning lamp pre-check</li> </ul>	OFF
		<ul style="list-style-type: none"> <li>Ignition switch: ON</li> <li>During warning lamp pre-check</li> </ul>	ON
02	Pass. SRS light "ON" request	<ul style="list-style-type: none"> <li>Ignition switch: ON</li> <li>After warning light pre-check</li> </ul>	OFF
		<ul style="list-style-type: none"> <li>Ignition switch: ON</li> <li>During warning light pre-check</li> </ul>	ON
03	Driver's seatbelt switch	<ul style="list-style-type: none"> <li>Ignition switch: ON</li> <li>After warning light pre-check</li> <li>Wear the driver seatbelt.</li> </ul>	Fastened
		<ul style="list-style-type: none"> <li>Ignition switch: ON</li> <li>After warning light pre-check</li> <li>Undo the driver seatbelt.</li> </ul>	Unfastened
04	Passenger's seatbelt switch	<ul style="list-style-type: none"> <li>Ignition switch: ON</li> <li>After warning light pre-check</li> <li>Wear the passenger seatbelt.</li> </ul>	Fastened
		<ul style="list-style-type: none"> <li>Ignition switch: ON</li> <li>After warning light pre-check</li> <li>Undo the passenger seatbelt.</li> </ul>	Unfastened
05	Passenger seat airbag ignition	<ul style="list-style-type: none"> <li>Ignition switch: ON</li> <li>After warning light pre-check</li> <li>Apply a load to the passenger seat.</li> </ul>	Permission
		<ul style="list-style-type: none"> <li>Ignition switch: ON</li> <li>After warning light pre-check</li> <li>Undo a load from a passenger seat.</li> </ul>	Prohibition

**ACTUATOR TEST**

The scan tool can be used to forcibly operate the next actuator.

Item No.	Display on M.U.T.-III	Test item	Driven component
01	SRS warning light	SRS warning light illumination	ON



SRS AIR BAG SPECIAL CONNECTOR

M2521009000466

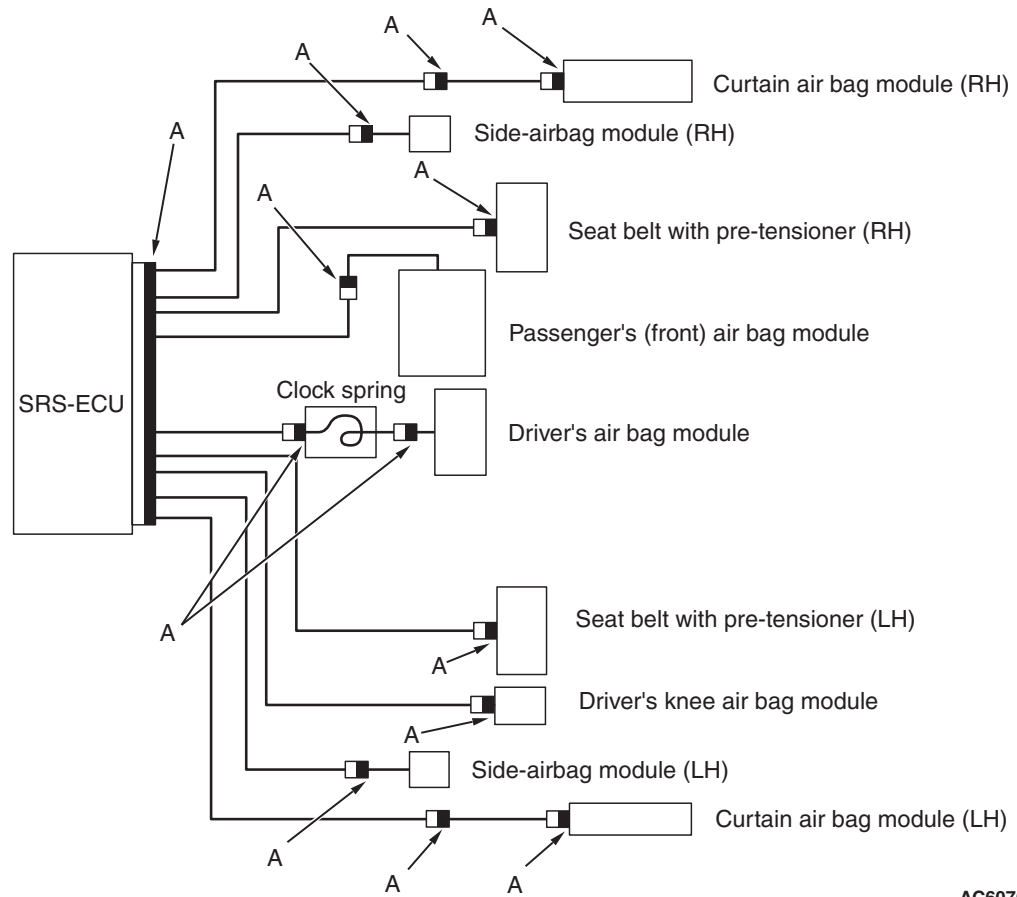

AC607646 AD

To enhance the system reliability, a connector short circuiting mechanism is integrated in the SRS-ECU connector, air bag module connectors, clock spring connector, and pre-tensioner connectors (black connector "A" shown in the figure).

## CONNECTOR SHORT-CIRCUIT MECHANISM

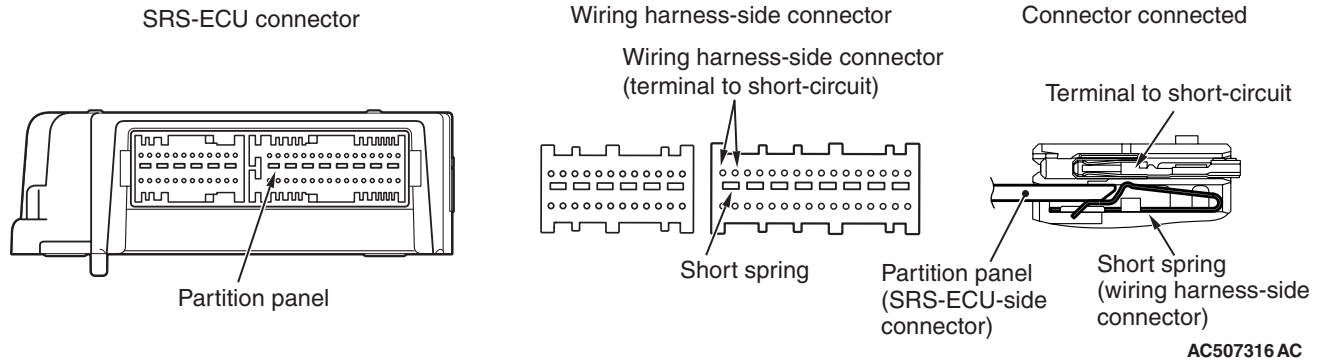

This mechanism prevents the improper deployment of air bag module because of the current application to the squib due to the static electricity when connectors between SRS-ECU and air bag modules (squibs) are disconnected. When the connector is disconnected, the short spring short circuits the power supply side terminal and ground side terminal of squibs, and prevents the static electricity from generating the potential difference. This connector mechanism is adopted for the following connectors.

- SRS-ECU connector
- Connector between the clock spring and body-side wiring harness
- Each air bag module connector
- Each pre-tensioner connector